



NI 43-101 TECHNICAL REPORT

# FEASIBILITY STUDY HORNE 5 GOLD PROJECT

ROUYN-NORANDA, QUÉBEC, CANADA

EFFECTIVE DATE: OCTOBER 5, 2017

SIGNATURE DATE: OCTOBER 30, 2017

**PREPARED BY QUALIFIED PERSONS:**

Colin Hardie, P. Eng. .... BBA Inc.  
 Pierre Lacombe, P. Eng. .... Lundin Mining Corp. (ex BBA Inc.)  
 Valérie Bertrand, P. Geo. .... Golder Associates Ltd.  
 Rob Bewick, P. Eng. .... Golder Associates Ltd.  
 Yves Boulianne, P. Eng. .... Golder Associates Ltd.  
 Michael Bratty, P. Eng. .... Golder Associates Ltd.  
 Janis Drozdiak, P. Eng. .... Golder Associates Ltd.  
 Mayana Kissiova, P. Eng. .... Golder Associates Ltd.  
 Michel Mailloux, P. Eng. .... Golder Associates Ltd.  
 Serge Ouellet, P. Eng. .... Golder Associates Ltd.

Yves Vallières, P. Eng. .... Ingénierie RIVAL Inc.  
 Geneviève Auger, P. Eng. .... InnovExplo Inc.  
 Patrick Frenette, P. Eng. .... InnovExplo Inc.  
 Carl Pelletier, P. Geo. .... InnovExplo Inc.  
 Luc Gaulin, P. Eng. .... SNC-Lavalin Stavibel Inc.  
 Marie-Claude Dion St-Pierre, P. Eng. .... WSP Canada Inc.  
 Claire Hayek, P. Eng. .... WSP Canada Inc.  
 Stéphane Lance, P. Eng. .... WSP Canada Inc.  
 Dominick Turgeon, P. Eng. .... WSP Canada Inc.

## **DISCLAIMER**

Pursuant to an agreement between Falco and a Third Party, Falco owns rights to the minerals located below 200 metres from the surface of mining concession CM-156PTB, where the Horne 5 deposit is located. Falco also owns certain surface rights surrounding the Quemont No. 2 shaft located on mining concession CM-243. Under the agreement, ownership of the mining concessions remains with the Third Party.

In order to access the Horne 5 Project, Falco must obtain one or more licenses from the Third Party, which may not be unreasonably withheld, but which may be subject to conditions that the Third Party may require in its sole discretion. These conditions may include the provision of a performance bond or other assurance to the Third Party and the indemnification of the Third Party by Falco. The agreement with the Third Party stipulates, among other things, that a license shall be subject to reasonable conditions which may include, among other things, that activities at Horne 5 will be subordinated to the current use of the surface lands and subject to priority, as established in such party's sole discretion, over such activities. Any license may provide for, among other things, access to and the right to use the infrastructure owned by the Third Party, including the Quemont No. 2 shaft (located on mining concession CM-243 held by such Third Party) and some specific underground infrastructure in the former Quemont and Horne mines.

Furthermore, Falco will have to acquire a number of rights of ways or other surface rights in order to construct the TMF and associated pipelines.

While Falco believes that it should be able to timely obtain the licenses from the Third Party and to acquire the required rights of way and other surface rights, there can be no assurance that any such license, rights of way or surface rights will be granted, or if granted will be on terms acceptable to Falco and in a timely manner.

Falco also notes that the timeline of activities described in this Report, and the estimated timing proposed for commencement and completion of such activities, is subject at all times to matters that are not within the exclusive control of Falco. These factors include the ability to obtain, and to obtain on terms acceptable to Falco, financing, governmental and other third party approvals, licenses, rights of way and surface rights (as described in Chapters 16, 18 and 20).

Although Falco believes that it has taken reasonable measures to ensure proper title to its assets, there is no guarantee that title to any of assets will not be challenged or impugned.

The foregoing disclaimer hereby qualifies in its entirety the disclosure contained in this Report.



## **IMPORTANT NOTICE**

This report was prepared as a National Instrument 43-101 *Standards of Disclosure for Mineral Projects* Technical Report for Falco Resources Ltd. (Falco) by BBA Inc. (BBA), InnovExplo Inc. (InnovExplo), Golder Associates Ltd. (Golder), WSP Canada Inc. (WSP), SNC–Lavalin Stavibel Inc. (SNC-Lavalin) and Ingénierie RIVVAL Inc. (RIVVAL) collectively known as the “Report Authors”. The quality of information, conclusions, and estimates contained herein is consistent with the level of effort involved in the Report Authors’ services, based on i) information available at the time of preparation, ii) data supplied by outside sources, and iii) the assumptions, conditions, and qualifications set forth in this report. This report is intended for use by Falco subject to the terms and conditions of its contract with the report authors and relevant securities legislation. The contract permits Falco to file this report as a Technical Report with Canadian securities regulatory authorities pursuant to National Instrument 43-101. Except for the purposes legislated under provincial securities law, any other uses of this report by any third party is at that party’s sole risk. The responsibility for this disclosure remains with Falco. The user of this document should ensure that this is the most recent Technical Report for the property as it is not valid if a new Technical Report has been issued.

## **FORWARD-LOOKING INFORMATION**

The results of this Report represent forward-looking information that is subject to a number of known and unknown risks, uncertainties and other factors that may cause actual results to differ materially from those presented here. Forward-looking statements in this Report include, but are not limited to, statements with respect to future metal prices, the estimation of Mineral Reserves and Mineral Resources, the realization of Mineral Reserve estimates, unexpected variations in quantity of mineralized material, grade or recovery rates, geotechnical and hydrogeological factors, unexpected variations in geotechnical and hydrogeological assumptions used in mine designs including seismic events and water management during the construction, operations, closure, and post-closure periods, the timing and amount of estimated future production, timing and costs of obtaining 3rd party licenses, costs of future production, capital expenditures, future operating costs, costs and timing of the development of new ore zones, success of exploration activities, permitting time lines and potential delays in the issuance of permits, currency exchange rate fluctuations, project financing success, requirements for additional capital, failure of plant, equipment or processes to operate as anticipated, government regulation of mining operations, environmental, permitting and social risks, unrecognized environmental, permitting and social risks, closure costs and closure requirements, unanticipated reclamation expenses, title disputes or claims and limitations on insurance coverage.

---

**DATE AND SIGNATURE PAGE**

This report is effective as of the 5th day of October 2017.

*“Original signed and sealed”*

\_\_\_\_\_  
Colin Hardie, P. Eng.  
BBA Inc.

\_\_\_\_\_  
October 30, 2017

\_\_\_\_\_  
Date

*“Original signed and sealed”*

\_\_\_\_\_  
Pierre Lacombe, P. Eng.  
Lundin Mining Corp. (ex BBA Inc.)

\_\_\_\_\_  
October 30, 2017

\_\_\_\_\_  
Date

*“Original signed and sealed”*

\_\_\_\_\_  
Carl Pelletier, P. Geo.  
InnovExplo Inc.

\_\_\_\_\_  
October 30, 2017

\_\_\_\_\_  
Date

*“Original signed and sealed”*

\_\_\_\_\_  
Patrick Frenette, P. Eng.  
InnovExplo Inc.

\_\_\_\_\_  
October 30, 2017

\_\_\_\_\_  
Date

*“Original signed and sealed”*

\_\_\_\_\_  
Geneviève Auger, P. Eng.  
InnovExplo Inc.

\_\_\_\_\_  
October 30, 2017

\_\_\_\_\_  
Date

*“Original signed and sealed”*

\_\_\_\_\_  
Michel Mailloux, P. Eng., M.Sc.  
Golder Associates Ltd.

\_\_\_\_\_  
October 30, 2017

\_\_\_\_\_  
Date

---

*“Original signed and sealed”*

Valérie J. Bertrand, Geo. M.A.Sc.  
Golder Associates Ltd.

---

October 30, 2017

Date

---

*“Original signed and sealed”*

Mayana Kissiova, P. Eng.  
Golder Associates Ltd.

---

October 30, 2017

Date

---

*“Original signed and sealed”*

Rob Bewick, Ph.D., P. Eng.  
Golder Associates Ltd.

---

October 30, 2017

Date

---

*“Original signed and sealed”*

Michael Bratty, P. Eng.  
Golder Associates Ltd.

---

October 30, 2017

Date

---

*“Original signed and sealed”*

Yves Boulianne, P. Eng.  
Golder Associates Ltd.

---

October 30, 2017

Date

---

*“Original signed and sealed”*

Janis Drozdiak, P. Eng.  
Golder Associates Ltd.

---

October 30, 2017

Date

---

*“Original signed and sealed”*

Serge Ouellet, P. Eng.  
Golder Associates Ltd.

---

October 30, 2017

Date

---

*“Original signed and sealed”*

Marie-Claude Dion St-Pierre, P. Eng.  
WSP Canada Inc.

---

October 30, 2017

Date

---

*“Original signed and sealed”*

Stéphane Lance, P. Eng.  
WSP Canada Inc.

---

October 30, 2017

Date

---

*“Original signed and sealed”*

Claire Hayek, Eng., MBA  
WSP Canada Inc.

---

October 30, 2017

Date

---

*“Original signed and sealed”*

Dominick Turgeon, P. Eng.  
WSP Canada Inc.

---

October 30, 2017

Date

---

*“Original signed and sealed”*

Luc Gaulin, Eng., MBA  
SNC-Lavalin Stavibel Inc.

---

October 30, 2017

Date

---

*“Original signed and sealed”*

Yves Vallières, P. Eng.  
Ingénierie RIVVAL Inc.

---

October 30, 2017

Date



## CERTIFICATE OF QUALIFIED PERSON

**Colin Hardie, P. Eng.**

This certificate applies to the **NI 43-101 Technical Report for the Horne 5 Gold Project Feasibility Study prepared for Falco Resources Ltd.** issued on October 30, 2017 (the "Technical Report") and effective October 5, 2017.

I, Colin Hardie, P. Eng., as a co-author of the Technical Report, do hereby certify that:

1. I am the Director of Mining and Process Studies with the firm BBA Inc. located at 2020 Robert-Bourassa Blvd., Suite 300, Montréal, Québec, H3A 2A5, Canada.
2. I graduated from the University of Toronto, Ontario Canada, in 1996 with a BAsC in Geological and Mineral Engineering. In 1999, I graduated from McGill University of Montréal, Québec Canada, with an M. Eng. in Metallurgical Engineering and in 2008 obtained a Master of Business Administration (MBA) degree from the University of Montréal (HEC), Québec Canada.
3. I am a member in good standing of the Professional Engineers of Ontario (PEO No: 90512500) and of the Canadian Institute of Mining, Metallurgy, and Petroleum (Member Number: 140556). I have practiced my profession continuously since my graduation.
4. I have been employed in mining operations, consulting engineering and applied metallurgical research for over 20 years. My relevant project experience includes metallurgical testwork analysis, flowsheet development, cost estimation and financial modeling. Since joining BBA in 2008, I have worked as a senior process engineer and/or lead study integrator for numerous North American iron ore, precious metal, industrial mineral, and base metal projects.
5. I have read the definition of "qualified person" set out in the NI 43-101 – Standards of Disclosure for Mineral Projects ("NI 43-101") and certify that, by reason of my education, affiliation with a professional association, and past relevant work experience, I fulfill the requirements to be a qualified person for the purposes of NI 43-101.
6. I am independent of the issuer applying all the tests in Section 1.5 of NI 43-101.
7. I am responsible for Chapters 1, 2, 3, 19, 21, 22 and 24 to 27. I also provided contributions to Chapters 18 and 21.
8. I have not visited the Horne 5 Project site that is the subject of the Technical Report.
9. I have had prior involvement with the property that is the subject of the Technical Report. I have contributed to the report entitled "NI 43-101 Technical Report for the Horne 5 Project Preliminary Economic Assessment" (effective date April 28, 2016) which was issued on June 23, 2016.
10. I have read NI 43-101 and the sections of the Technical Report for which I am responsible have been prepared in compliance with NI 43-101.
11. As at the effective date of the Technical Report, to the best of my knowledge, information and belief, the sections of the Technical Report for which I am responsible contain all scientific and technical information that is required to be disclosed to make the portions of the Technical Report for which I am responsible not misleading.

Dated this 30<sup>th</sup> day of October, 2017

*"Signed and sealed"*

---

Colin Hardie, P. Eng.

## CERTIFICATE OF QUALIFIED PERSON

**Pierre Lacombe, P. Eng.**

This certificate applies to the **NI 43-101 Technical Report for the Horne 5 Gold Project Feasibility Study prepared for Falco Resources Ltd.** issued on October 30, 2017 (the "Technical Report") and effective October 5, 2017.

I, Pierre Lacombe, P. Eng., as a co-author of the Technical Report, do hereby certify that:

1. I am a Group Metallurgist with Lundin Mining Corp located at 150 King St. W., Toronto, Ontario, and formerly with BBA as Expert, Metallurgy in their Montréal office during the course of preparation of the Technical Report.
2. I am a graduate of École Polytechnique of Montréal, Montréal, Québec, Canada with a B. Eng. in Mining Engineering, with specialization in Mineral Processing.
3. I am a member in good standing of the Order des Ingénieurs du Québec (OIQ No. 39496).
4. My relevant experience includes 33 years in the mining industry, holding various roles in base metals operations before being involved in the engineering of projects, first for a mining company and then through position as consultant. During this period, I also served as an executive of mining companies.
5. I have read the definition of "qualified person" set out in the NI 43-101 – Standards of Disclosure for Mineral Projects ("NI 43-101") and certify that, by reason of my education, affiliation with a professional association, and past relevant work experience, I fulfill the requirements to be a qualified person for the purposes of NI 43-101.
6. I am independent of the issuer applying all the tests in Section 1.5 of NI 43-101.
7. I am responsible for the preparation of Chapters 13 (with the exception of Section 13.8), 17, and for the preparation of Section 21.2.4. I am also responsible for the portions of Chapters 1, 21, 25, 26, and 27 relevant to mineral processing and metallurgy of the Technical Report.
8. I did not personally visit the property that is the subject of the Technical Report.
9. I have had no prior involvement with the property that is the subject of the Technical Report, other than through the preparation of the earlier Technical Report, while with BBA Inc., entitled "Preliminary Economic Assessment of the Horne 5 Project, Québec, Canada", with an effective date of April 28, 2016, as released by the same issuer.
10. I have read NI 43-101 and the sections of the Technical Report for which I am responsible have been prepared in compliance with NI 43-101.
11. As at the effective date of the Technical Report, to the best of my knowledge, information and belief, the sections of the Technical Report for which I am responsible contain all scientific and technical information that is required to be disclosed to make the portions of the Technical Report for which I am responsible not misleading.

Dated this 30<sup>th</sup> day of October, 2017

*"Signed and sealed"*

---

Pierre Lacombe, P. Eng.

## CERTIFICATE OF QUALIFIED PERSON

### Carl Pelletier, P. Geo

This certificate applies to the **NI 43-101 Technical Report for the Horne 5 Gold Project Feasibility Study prepared for Falco Resources Ltd.** issued on October 30, 2017 (the "Technical Report") and effective October 5, 2017.

I, Carl Pelletier, P. Geo. (OGQ #384) as a co-author of the Technical Report, do hereby certify that:

1. I am employed as a consulting geologist by, and carried out this assignment for, InnovExplo Inc, 560, 3e Avenue, Val-d'Or, Québec, Canada.
2. I graduated with a Bachelor's degree in geology (B.Sc.) from Université du Québec à Montréal (Montréal, Québec) in 1992, and I initiated a Master's degree at the same university for which I completed the course program but not the thesis.
3. I am a member of the Ordre des Géologues du Québec (OGQ No. 384), the Association of Professional Geoscientists of Ontario (APGO No. 1713), the Professional Engineers and Geoscientist of British Columbia (APEGBC No. 43167) and of the Canadian Institute of Mines (CIM).
4. My relevant experience includes a total of 25 years since my graduation from university. My mining expertise has been acquired in the Silidor, Sleeping Giant, Bousquet II, Sigma-Lamaque and Beaufor mines, whereas my exploration experience has been acquired with Cambior Inc. and McWatters Mining Inc. I have been a consulting geologist for InnovExplo Inc. since February 2004.
5. I have read the definition of "qualified person" set out in the NI 43-101 – Standards of Disclosure for Mineral Projects ("NI 43-101") and certify that, by reason of my education, affiliation with a professional association, and past relevant work experience, I fulfill the requirements to be a qualified person for the purposes of NI 43-101.
6. I am independent of the issuer applying all the tests in Section 1.5 of NI 43-101.
7. I am responsible for the preparation of Chapters 4 to 12, 14 and 23. I am also responsible for contributions to Chapters 1, 25, 26, and 27 of the Technical Report.
8. I personally visited the property that is the subject of the Technical Report on June 4, 2015.
9. I have had prior involvement with the property that is the subject of the Technical Report. I have contributed to reports on the property that is the subject of the "Technical Report" on behalf of the issuer in April 2014, January 2016 and November 2016 as well as in the report prepared by BBA issued on June 2016.
10. I have read NI 43-101 and the sections of the Technical Report for which I am responsible have been prepared in compliance with NI 43-101.
11. As at the effective date of the Technical Report, to the best of my knowledge, information and belief, the sections of the Technical Report for which I am responsible contain all scientific and technical information that is required to be disclosed to make the portions of the Technical Report for which I am responsible not misleading.

Dated this 30<sup>th</sup> day of October, 2017

*"Signed and sealed"*

---

Carl Pelletier, P. Geo, B.Sc.

## CERTIFICATE OF QUALIFIED PERSON

**Patrick Frenette, P. Eng.**

This certificate applies to the **NI 43-101 Technical Report for the Horne 5 Gold Project Feasibility Study prepared for Falco Resources Ltd.**, issued on October 30, 2017 (the "Technical Report") and effective October 5, 2017.

I, Patrick Frenette, P. Eng., M.A.Sc., do hereby certify that:

1. I am employed as a consulting engineer by, and carried out this assignment for, InnovExplo Inc., 560, 3e Avenue, Val-d'Or, Québec, Canada.
2. I graduated with a Bachelor's Degree in Mining Engineering (B.ing.) in 2001 from École Polytechnique de Montréal, Montréal, Québec, Canada. In addition, I obtained a Master's Degree in Applied Sciences (M.A.Sc.) in 2003 from École Polytechnique de Montréal, Québec, Canada. I have practiced my profession continuously since my graduation from university.
3. I am a member in good standing of the Ordre des Ingénieurs du Québec (OIQ No. 129575).
4. I have worked in the mining industry for more than fourteen (14) years. My mining experience has been acquired at the Doyon, Goldex and Canadian Malartic mines and at Agnico Eagle's technical services division. I have been a consulting engineer for InnovExplo Inc. since April 2016.
5. I have read the definition of "qualified person" set out in the NI 43-101 – Standards of Disclosure for Mineral Projects ("NI 43-101") and certify that, by reason of my education, affiliation with a professional association, and past relevant work experience, I fulfill the requirements to be a qualified person for the purposes of NI 43-101.
6. I am independent of the issuer applying all the tests in Section 1.5 of NI 43-101.
7. I am responsible for the preparation of Chapter 15 and Sections 16.1, 16.5.5, 16.6, 16.6.6, and 16.7 (except 16.7.3). I am also responsible for contributions to Chapters 1, 21, 25, 26, and 27 of the Technical Report.
8. I visited the site on August 30, 2016, accompanied by Paul Létourneau of Falco, Patrick Martel of TechnoSub and François Girard of Osisko Gold Royalties.
9. I contributed to the June 2016 PEA report prepared by BBA.
10. I have read NI 43-101 and the sections of the Technical Report for which I am responsible have been prepared in compliance with NI 43-101.
11. As at the effective date of the Technical Report, to the best of my knowledge, information and belief, the sections of the Technical Report for which I am responsible contain all scientific and technical information that is required to be disclosed to make the portions of the Technical Report for which I am responsible not misleading.

Dated this 30<sup>th</sup> day of October, 2017

*"Signed and sealed"*

---

Patrick Frenette, P.Eng., M.A.Sc.



## CERTIFICATE OF QUALIFIED PERSON

**Geneviève Auger, P. Eng., M.Sc.A.**

This certificate applies to the **NI 43-101 Technical Report for the Horne 5 Gold Project Feasibility Study prepared for Falco Resources Ltd.** issued on October 30, 2017 (the “Technical Report”) and effective October 5, 2017.

I, Geneviève Auger, P. Eng. M.Sc.A., as a co-author of the Technical Report, do hereby certify that:

1. I am employed as a consulting engineer by, and carried out this assignment for, InnovExplo Inc., located at 506, 3e avenue, Val d'or, Québec, Canada.
2. I am a graduate of Bachelor's Degree in Mining engineering (B.ing.) in 1998 from École Polytechnique de Montréal (Montréal, Québec, Canada). In addition, I obtained a Master's Degree in Applied Sciences (M.Sc.A.) in 2001 from École Polytechnique de Montréal, Québec, Canada. I have practiced my profession continuously since my graduation from university.
3. I am a member in good standing of Ordre des Ingénieurs du Québec (OIQ No. 121367).
4. I have worked in the mining industry for more than nine (9) years. I have been a consulting engineer for InnovExplo Inc. since November 2016.
5. I have read the definition of “qualified person” set out in the NI 43-101 – Standards of Disclosure for Mineral Projects (“NI 43-101”) and certify that, by reason of my education, affiliation with a professional association, and past relevant work experience, I fulfill the requirements to be a qualified person for the purposes of NI 43-101.
6. I am independent of the issuer applying all the tests in Section 1.5 of NI 43-101.
7. I am co-responsible for the preparation of Sections 16.4, 16.5.1 to 16.5.4, 16.6.2, 16.6.4, 16.6.5, 16.7.3, 16.10, and 16.11. I am also responsible for contributions to Chapters 1, 21, 25, 26, and 27 of the Technical Report.
8. I personally did not visit the property that is the subject of the Technical Report.
9. I have had no prior involvement with the property that is the subject of the Technical Report.
10. I have read NI 43-101 respecting standards of disclosure for mineral projects and Form 43-101F1, and the sections of the Technical Report for which I was responsible have been prepared in accordance with that instrument/regulation and form. I have read NI 43-101 and the sections of the Technical Report for which I am responsible have been prepared in compliance with NI 43-101.
11. As at the effective date of the Technical Report, to the best of my knowledge, information and belief, the sections of the Technical Report for which I am responsible contain all scientific and technical information that is required to be disclosed to make the portions of the Technical Report for which I am responsible not misleading.

Dated this 30<sup>th</sup> day of October, 2017.

*“Signed and sealed”*

---

Geneviève Auger, P. Eng., M.Sc.A.

## CERTIFICATE OF QUALIFIED PERSON

**Michel Mailloux, P. Eng., M. Sc.**

This certificate applies to the **NI 43-101 Technical Report for the Horne 5 Gold Project Feasibility Study prepared for Falco Resources Ltd.** issued on October 30, 2017 (the "Technical Report") and effective October 5, 2017.

I, Michel Mailloux, P. Eng., M. Sc., as a co-author of the Technical Report, do hereby certify that:

1. I am a Hydrogeologist with the firm Golder Associates Ltd. with an office located at 7250 Mile End St., 3<sup>rd</sup> floor, Montreal, Québec, Canada.
2. I am a graduate of Laval University, Québec-City, Canada, with a B.Sc. A. Geological Engineering in 1998 and a graduate from INRS-Georessources M. Sc. Earth Sciences in 2002. I have practiced my profession continuously since my graduation from university.
3. I am a member in good standing of the Order of Engineers of Québec (OIQ No. 126263)
4. My relevant experiences include the technical supervision of several hydrogeological studies for local and international mining projects.
5. I have read the definition of "qualified person" set out in the NI 43-101 – Standards of Disclosure for Mineral Projects ("NI 43-101") and certify that, by reason of my education, affiliation with a professional association, and past relevant work experience, I fulfill the requirements to be a qualified person for the purposes of NI 43-101.
6. I am independent of the issuer applying all the tests in Section 1.5 of NI 43-101.
7. I am responsible for the preparation of Chapter 16, Section 16.3 Mine Hydrogeology. I am also responsible for contributions to Chapters 1, 25, 26, and 27 of the Technical Report.
8. I visited the property that is the subject of the Technical Report in November, 2016.
9. I have had prior involvement in the Technical Report and Mineral Resource Estimate for Horne 5 Deposit (in which I was responsible for Sections 16.2.7, 16.2.8, 18.21 and 20.2.6, and those portions of the summary, Capital and Operating costs, conclusions and recommendations that were based on those sections) with the property that is the subject of the Technical Report.
10. I have read NI 43-101 and the sections of the Technical Report for which I am responsible have been prepared in compliance with NI 43-101.
11. As at the effective date of the Technical Report, to the best of my knowledge, information and belief, the sections of the Technical Report for which I am responsible contain all scientific and technical information that is required to be disclosed to make the portions of the Technical Report for which I am responsible not misleading.

Dated this 30<sup>th</sup> day of October, 2017

*"Signed and sealed"*

---

Michel Mailloux, P. Eng., M. Sc.

## CERTIFICATE OF QUALIFIED PERSON

**Valérie Johanne Bertrand, géo, M.Sc.A.**

This certificate applies to the **NI 43-101 Technical Report for the Horne 5 Gold Project Feasibility Study prepared for Falco Resources Ltd.** issued on October 30, 2017 (the "Technical Report") and effective October 5, 2017.

I, Valérie Bertrand, Geologist, as a co-author of the Technical Report, do hereby certify that:

1. I am an Associate and Senior Geochemist with the firm Golder Associates Ltd with an office located at 1931 Robertson Road, Ottawa Ontario, Canada.
2. I am a graduate of University of Ottawa (Ottawa, Canada) with a Bachelor's degree in Geology in 1991 and University of British Columbia (Vancouver, Canada) with a Master's degree in Mining Engineering in 1999. I have worked as a geologist for a total of 26 years since my graduation from university.
3. I am a registered Professional Geoscientist in Ontario (APGO No. 1458), in Northwest Territories and Nunavut (NAPEG No. L1811) and a member in good standing of l'Ordre des Géologues du Québec (OGQ No. 1221).
4. My relevant experience includes geochemical analysis of mine wastes, water, and contaminant behaviour in soils, mine wastes and water. I specialize in technical evaluations related to mine wastes, mine water chemistry and their management, industrial contaminant assessments and modelling of geochemical processes and water quality.
5. I have read the definition of "qualified person" set out in the NI 43-101 – Standards of Disclosure for Mineral Projects ("NI 43-101") and certify that, by reason of my education, affiliation with a professional association, and past relevant work experience, I fulfill the requirements to be a qualified person for the purposes of NI 43-101.
6. I am independent of the issuer applying all the tests in Section 1.5 of NI 43-101.
7. I am responsible for the preparation of Chapter 20, Sections 20.2.2 Geochemical Assessment – Ore, Tailings, Waste Rock and Process Water and 20.2.9 Site Water Quality Prediction. I am also responsible for contributions to Chapters 1, 25, 26, and 27 of the Technical Report.
8. I personally visited the property that is the subject of the Technical Report on May 21, 2015.
9. I have had prior involvement in the Technical Report and Mineral Resource Estimate for Horne 5 Deposit (in which I was responsible for Section 20.2.1 and those portions of the summary, conclusions and recommendations that were based on that section) with the property that is the subject of the Technical Report.
10. I have read NI 43-101 and the sections of the Technical Report for which I am responsible have been prepared in compliance with NI 43-101.
11. As at the effective date of the Technical Report, to the best of my knowledge, information and belief, the sections of the Technical Report for which I am responsible contain all scientific and technical information that is required to be disclosed to make the portions of the Technical Report for which I am responsible not misleading.

Dated this 30<sup>th</sup> day of October, 2017

*"Signed and sealed"*

---

Valérie J. Bertrand, géo, M.Sc.A.

## CERTIFICATE OF QUALIFIED PERSON

**Mayana Kissiova, P. Eng.**

This certificate applies to the **NI 43-101 Technical Report for the Horne 5 Gold Project Feasibility Study prepared for Falco Resources Ltd.** issued on October 30, 2017 (the "Technical Report") and effective October 5, 2017.

I, Mayana Kissiova, P. Eng., as a co-author of the Technical Report, do hereby certify that:

1. I am a Principal and Senior Tailings Engineer with the firm Golder Associates Ltd. with an office located at 7250, Mile End St., 3<sup>rd</sup> floor, Montréal, Québec, Canada.
2. I am a graduate of University of Civil Engineering and Architecture, Sofia, Bulgaria, with a Bachelor in Civil Engineering in 1992 and from École Polytechnique de Montréal, Québec, Canada, with a Master in Mineral Engineering in 1995.
3. I am a member in good standing of l'Ordre des Ingénieurs du Québec (OIQ No. 110251).
4. My relevant experience includes tailing and waste rock management and design of storage facilities assuming the role of Lead Engineer, Manager or Director on projects for several stages of development (from scoping to detailed design and construction), including closure planning and design. I have been responsible for numerous stability assessments, designs and construction campaigns, as well as reviews of existing facilities.
5. I have read the definition of "qualified person" set out in the NI 43-101 – Standards of Disclosure for Mineral Projects ("NI 43-101") and certify that, by reason of my education, affiliation with a professional association, and past relevant work experience, I fulfill the requirements to be a qualified person for the purposes of NI 43-101.
6. I am independent of the issuer applying all the tests in Section 1.5 of NI 43-101.
7. I am responsible for the preparation of Chapter 18, Sections 18.21 and 18.22, and Chapter 20, Sections 20.2.1, 20.2.3 through 20.2.8. I am also responsible for contributions to Chapters 1, 21, 25, 26, and 27 of the Technical Report.
8. I personally visited the property that is the subject of the Technical Report on November 18, 2015.
9. I have had prior involvement in the Technical Report and Mineral Resource Estimate for Horne 5 Deposit (in which I was responsible for Sections 20.2.2 to 20.2.5 and 21.3.3, and those portions of the summary, conclusions and recommendations that were based on those sections) with the property that is the subject of the Technical Report.
10. I have read NI 43-101 and the sections of the Technical Report for which I am responsible have been prepared in compliance with NI 43-101.
11. As at the effective date of the Technical Report, to the best of my knowledge, information and belief, the sections of the Technical Report for which I am responsible contain all scientific and technical information that is required to be disclosed to make the portions of the Technical Report for which I am responsible not misleading.

Dated this 30<sup>th</sup> day of October, 2017

*"Signed and sealed"*

---

Mayana Kissiova, P. Eng.



## CERTIFICATE OF QUALIFIED PERSON

**Robert Bewick, Ph.D., P. Eng.**

This certificate applies to the **NI 43-101 Technical Report for the Horne 5 Gold Project Feasibility Study prepared for Falco Resources Ltd.** issued on October 30, 2017 (the "Technical Report") and effective October 5, 2017.

I, Robert Bewick, Ph.D., P. Eng., as a co-author of the Technical Report, do hereby certify that:

1. I am an Associate and Senior Rock Mechanics Engineer with the firm Golder Associates Ltd. with an office at 33 Mackenzie Street, Suite 100, Sudbury, Ontario, Canada.
2. I am a graduate of Laurentian University, Sudbury, Ontario, Canada, with a B. Eng. in Mining Engineering in 2005, and with an M.A.Sc. in Mineral Resources Engineering in 2008, and the University of Toronto, Ontario, Canada, with a Ph.D., in Civil Engineering in 2013. I have practiced my profession continuously since my graduation from university in 2005.
3. I am a registered member in good standing of Professional Engineers Ontario (PEO No. 100103318) and I am a member of the Canadian Institute of Mining.
4. My relevant experience includes deep and shallow underground hard rock engineering. My primary underground experience is complimented by crown pillar and large open pit slope site characterization and design, as well as rock mechanics innovations for block caving.
5. I have read the definition of "qualified person" set out in the NI 43-101 – Standards of Disclosure for Mineral Projects ("NI 43-101") and certify that, by reason of my education, affiliation with a professional association, and past relevant work experience, I fulfill the requirements to be a qualified person for the purposes of NI 43-101.
6. I am independent of the issuer applying all the tests in Section 1.5 of NI 43-101.
7. I am responsible for the preparation of Chapter 16, Section 16.2 Rock Engineering. I am also responsible for contributions to Chapters 1, 25, 26, and 27 of the Technical Report.
8. I personally visited the property that is the subject of the Technical Report on October 6, 2015.
9. I have had prior involvement in the Technical Report and Mineral Resource Estimate for Horne 5 Deposit (in which I was responsible for Section 16.2 (introduction), 16.2.2, 16.2.3, 16.2.4, 16.2.6 and those portions of the summary, conclusions and recommendations that were based on those sections) with the property that is the subject of the Technical Report.
10. I have read NI 43-101 and the sections of the Technical Report for which I am responsible have been prepared in compliance with NI 43-101.
11. As at the effective date of the Technical Report, to the best of my knowledge, information and belief, the sections of the Technical Report for which I am responsible contain all scientific and technical information that is required to be disclosed to make the portions of the Technical Report for which I am responsible not misleading.

Dated this 30<sup>th</sup> day of October, 2017

*"Signed and sealed"*

---

Robert Bewick, Ph.D., P. Eng.

## CERTIFICATE OF QUALIFIED PERSON

**Michael Bratty, M. Eng., P. Eng.**

This certificate applies to the **NI 43-101 Technical Report for the Horne 5 Gold Project Feasibility Study prepared for Falco Resources Ltd.** issued on October 30, 2017 (the "Technical Report") and effective October 5, 2017.

I, Michael Bratty, P. Eng., M. Eng., as a co-author of the Technical Report, do hereby certify that:

1. I am an Associate, Senior Mine Water Treatment Engineer with the firm Golder Associated Ltd., with an office located at Suite 200 - 2920 Virtual Way, Vancouver, British Columbia, Canada.
2. I am a graduate of University of BC, Vancouver, Canada, with a B.A.Sc. in Bioresource Engineering in 1991 and from McGill University (Montréal, Canada) with an M.Eng in Chemical Engineering in 2003.
3. I am a member in good standing of Association of Professional Engineers and Geoscientists of British Columbia (APEGBC No. 23936).
4. My relevant experience includes the development of water treatment facilities for clients in the mining industry from project conception, cost estimates, process development, pilot testing, regulatory and stakeholder approvals, detailed design, construction and operations. My experience includes metals and sulphate removal from acid rock drainage, sulphide precipitation and metal recovery, membrane separation, various ion exchange processes, cyanide recycle or treatment, water recycle, control of scaling, selenium treatment, passive treatment, and various biological processes.
5. I have read the definition of "qualified person" set out in the NI 43-101 – Standards of Disclosure for Mineral Projects ("NI 43-101") and certify that, by reason of my education, affiliation with a professional association, and past relevant work experience, I fulfill the requirements to be a qualified person for the purposes of NI 43-101.
6. I am independent of the issuer applying all the tests in Section 1.5 of NI 43-101.
7. I am responsible for the preparation of Chapter 18, Section 18.23 (Water treatment infrastructure). I am also responsible for contributions to Chapters 1, 21, 25, 26, and 27 of the Technical Report.
8. I personally visited the property that is the subject of the Technical Report on February 16, 2017.
9. I have had no prior involvement with the property that is the subject of the Technical Report.
10. I have read NI 43-101 and the sections of the Technical Report for which I am responsible have been prepared in compliance with NI 43-101.
11. As at the effective date of the Technical Report, to the best of my knowledge, information and belief, the sections of the Technical Report for which I am responsible contain all scientific and technical information that is required to be disclosed to make the portions of the Technical Report for which I am responsible not misleading.

Dated this 30<sup>th</sup> day of October, 2017

*"Signed and sealed"*

---

Michael Bratty, P. Eng., M. Eng.

## CERTIFICATE OF QUALIFIED PERSON

**Yves Boulianne, P. Eng.**

This certificate applies to the **NI 43-101 Technical Report for the Horne 5 Gold Project Feasibility Study prepared for Falco Resources Ltd.** issued on October 30, 2017 (the “Technical Report”) and effective October 5, 2017.

I, Yves Boulianne, P. Eng., as a co-author of the Technical Report, do hereby certify that:

1. I am an Associate, Senior Geotechnical Engineer and Waste Management Specialist with Golder Associates Ltée with an office at 7250 Mile End St., 3<sup>rd</sup> floor, Montréal, Québec, Canada.
2. I am a graduate of the Université du Québec à Chicoutimi, Chicoutimi, Canada, with a B.Sc. in Geological Engineering in 1999 and I have 17 years of experience related to the mining industry.
3. I am a member in good standing of l'Ordre des Ingénieurs du Québec (OIQ No. 127801) and a professional engineer in the Northwest Territories and Nunavut.
4. My relevant experience includes mine waste and tailings facility designs, construction, and project management for conceptual, pre-feasibility, feasibility and detailed designs for tailings deposition and dams for surface waste facilities, including dewatered, thickened, and slurry type tailings. For various projects, I've been responsible for providing dam safety inspections, engineer of record services, due diligence and peer reviews, and operational support. I have experience linking engineering design, operation, and environmental facets of projects, especially in Québec and the Canadian arctic. I also provide civil geotechnical support for mines in the areas of haul roads, access roads, and foundations.
5. I have read the definition of “qualified person” set out in the NI 43-101 – Standards of Disclosure for Mineral Projects (“NI 43-101”) and certify that, by reason of my education, affiliation with a professional association, and past relevant work experience, I fulfill the requirements to be a qualified person for the purposes of NI 43-101.
6. I am independent of the issuer applying all the tests in Section 1.5 of NI 43-101.
7. I am responsible for the preparation of Chapter 18, Section 18.4 Geotechnical studies. I am also responsible for contributions to Chapters 1, 25, 26, and 27 of the Technical Report.
8. I personally did not visit the property that is the subject of the Technical Report.
9. I have had no prior involvement with the property that is the subject of the Technical Report.
10. I have read NI 43-101 and the sections of the Technical Report for which I am responsible have been prepared in compliance with NI 43-101.
11. As at the effective date of the Technical Report, to the best of my knowledge, information and belief, the sections of the Technical Report for which I am responsible contain all scientific and technical information that is required to be disclosed to make the portions of the Technical Report for which I am responsible not misleading.

Dated this 30<sup>th</sup> day of October, 2017

*“Signed and sealed”*

---

Yves Boulianne, P. Eng.

## CERTIFICATE OF QUALIFIED PERSON

**Janis Drozdiak, P. Eng.**

This certificate applies to the **NI 43-101 Technical Report for the Horne 5 Gold Project Feasibility Study prepared for Falco Resources Ltd.** issued on October 30, 2017 (the "Technical Report") and effective October 5, 2017.

I, Janis Drozdiak, P. Eng., as a co-author of the Technical Report, do hereby certify that:

1. I am a Senior Pipeline Engineer with Golder Associates Inc. located at 200 -2920 Virtual Way, Vancouver, British Columbia, Canada.
2. I am a graduate of University of British Columbia, Vancouver, Canada, with a B.A.Sc. in Chemical Engineering in 2001.
3. I am a member in good standing of Association of Professional Engineers and Geoscientists of British Columbia (APEGBC No. 30359) and Northwest Territories and Nunavut Association of Engineers and Geoscientists (NAPEG No. L3465).
4. My relevant experience includes the configuration and design of pipeline transportation systems for mine tailings, mineral concentrate slurries, paste, water and oil with a focus on long distance slurry and tailings pipelines for the mining industry. I have assumed the responsibility of both process engineering lead and project manager on pipeline projects ranging from conceptual studies to detailed design for process configuration, tailings classification design, tailings pump and launder design, pipeline route selection, pit dewatering and reclaim water design.
5. I have read the definition of "qualified person" set out in the NI 43-101 – Standards of Disclosure for Mineral Projects ("NI 43-101") and certify that, by reason of my education, affiliation with a professional association, and past relevant work experience, I fulfill the requirements to be a qualified person for the purposes of NI 43-101.
6. I am independent of the issuer applying all the tests in Section 1.5 of NI 43-101.
7. I am responsible for the preparation of Chapter 18, Sections 18.24 to 18.26. I am also responsible for contributions to Chapters 1, 21, 25, 26, and 27 of the Technical Report.
8. I personally did not visit the property that is the subject of the Technical Report.
9. I have had no prior involvement with the property that is the subject of the Technical Report.
10. I have read NI 43-101 and the sections of the Technical Report for which I am responsible have been prepared in compliance with NI 43-101.
11. As at the effective date of the Technical Report, to the best of my knowledge, information and belief, the sections of the Technical Report for which I am responsible contain all scientific and technical information that is required to be disclosed to make the portions of the Technical Report for which I am responsible not misleading.

Dated this 30<sup>th</sup> day of October, 2017

*"Signed and sealed"*

---

Janis Drozdiak, P. Eng.



## CERTIFICATE OF QUALIFIED PERSON

**Serge Ouellet, P. Eng.**

This certificate applies to the **NI 43-101 Technical Report for the Horne 5 Gold Project Feasibility Study prepared for Falco Resources Ltd.** issued on October 30, 2017 (the “Technical Report”) and effective October 5, 2017.

I, Serge Ouellet, P. Eng., as a co-author of the Technical Report, do hereby certify that:

1. I am Geological Engineer and Project Director with Golder Associates Ltd. with an office located at 375 Ave Centrale, Bureau 102, Val-d’Or, Québec, Canada.
2. I graduated from Laval University, Québec City, Canada, with a B.Sc.A in Geological Engineering in 1992 and a M.Sc. in 1995. I graduated from Université du Québec en Abitibi-Témiscamingue, Rouyn-Noranda, Québec, Canada, with a Ph.D. in Environmental Sciences in 2006.
3. I am a member in good standing of the Ordre des Ingénieurs du Québec (OIQ No. 109358).
4. My relevant experience includes 5 years as R&D Project Manager with Val-d’Or Sagax and Abitibi Geophysics, 5 years as part time Research Agent with Unité de Recherche et de Service en Technologie Minérale (URSTM), 1 year as Environmental Engineer with Genivar LP, 2 years as Director of Geotechnical Services with Genivar LP, 7 years as Senior Project Engineer with Agnico Eagle Mines Ltd., and since February 2016 Project Director and Val-d’Or Office Lead with Golder Associates Inc.
5. I have read the definition of “qualified person” set out in the NI 43-101 – Standards of Disclosure for Mineral Projects (“NI 43-101”) and certify that, by reason of my education, affiliation with a professional association, and past relevant work experience, I fulfill the requirements to be a qualified person for the purposes of NI 43-101.
6. I am independent of the issuer applying all the tests in Section 1.5 of NI 43-101.
7. I am responsible for contributions to Chapter 16, Sections 16.8 and 16.9. I am also responsible for contributions to Chapters 21, 25, 26, and 27 of the Technical Report.
8. I personally visited the property that is the subject of the Technical Report on August 30, 2016.
9. I have had no prior involvement with the property that is the subject of the Technical Report.
10. I have read NI 43-101 and the sections of the Technical Report for which I am responsible have been prepared in compliance with NI 43-101.
11. As at the effective date of the Technical Report, to the best of my knowledge, information and belief, the sections of the Technical Report for which I am responsible contain all scientific and technical information that is required to be disclosed to make the portions of the Technical Report for which I am responsible not misleading.

Dated this 30<sup>th</sup> day of October, 2017

*“Signed and sealed”*

---

Serge Ouellet, P. Eng.

## CERTIFICATE OF QUALIFIED PERSON

**Marie-Claude Dion St-Pierre, P. Eng.**

This certificate applies to the **NI 43-101 Technical Report for the Horne 5 Gold Project Feasibility Study prepared for Falco Resources Ltd.** issued on October 30, 2017 (the "Technical Report") and effective October 5, 2017.

I, Marie-Claude Dion St-Pierre, P. Eng., as a co-author of the Technical Report, do hereby certify that:

1. I am a Project Director with WSP Canada Inc. located at 1135 boul. Lebourgneuf, Québec, Canada.
2. I am a graduate of Sherbrooke University, Sherbrooke, Québec, Canada, with a Bachelor's degree in Chemical Engineering, in 2004 and Master's degree in Chemical Engineering in 2007.
3. I am a member in good standing of the Ordre des Ingénieurs du Québec (OIQ No. 140947).
4. My relevant experience includes studies as Project Manager on characterization of mining wastes, characterization of surface water, proposed solutions for treatment of mine water effluent, as well as, studies on water management infrastructures design. I also acted as Project Manager on mine closure plan design and costing, as well as, the other aspects of permitting for mining projects and mines in operation.
5. I have read the definition of "qualified person" set out in the NI 43-101 – Standards of Disclosure for Mineral Projects ("NI 43-101") and certify that, by reason of my education, affiliation with a professional association, and past relevant work experience, I fulfill the requirements to be a qualified person for the purposes of NI 43-101.
6. I am independent of the issuer applying all the tests in Section 1.5 of NI 43-101.
7. I am responsible for the preparation of Sections 20.1 and 20.3 to 20.6. I am also responsible for contributions to Chapters 1, 21 (as per Table 2-2), 25, 26, and 27 of the Technical Report.
8. I personally did not visit the property that is the subject of the Technical Report.
9. I have had prior involvement with the property that is the subject of the Technical Report. I have contributed to the report entitled "NI 43-101 Technical Report for the Horne 5 Project Preliminary Economic Assessment" (effective date April 28, 2016) which was issued on June 23, 2016.
10. I have read NI 43-101 and the sections of the Technical Report for which I am responsible have been prepared in compliance with NI 43-101.
11. As at the effective date of the Technical Report, to the best of my knowledge, information and belief, the sections of the Technical Report for which I am responsible contain all scientific and technical information that is required to be disclosed to make the portions of the Technical Report for which I am responsible not misleading.

Dated this 30<sup>th</sup> day of October, 2017

*"Signed and sealed"*

---

Marie-Claude Dion St-Pierre, P. Eng.

## CERTIFICATE OF QUALIFIED PERSON

**Stéphane Lance, P. Eng.**

This certificate applies to the **NI 43-101 Technical Report for the Horne 5 Gold Project Feasibility Study prepared for Falco Resources Ltd.** issued on October 30, 2017 (the “Technical Report”) and effective October 5, 2017.

I, Stéphane Lance, P. Eng., as a co-author of the Technical Report, do hereby certify that:

1. I am a Director – Mining Infrastructures - Québec with WSP Canada Inc., located at 1075, 3e Avenue Est, Val-d’Or, Québec, Canada.  
I am a graduate of Université du Québec, École de technologie supérieure with a Bachelor’s Degree in Mechanical Engineering in 1995 and Collège de St-Jean-sur-Richelieu, Québec, with a Diploma of college studies, Mechanical Engineering in 1991.  
I am a member in good standing of Ordre des Ingénieurs du Québec (OIQ No. 116195) and Professional Engineers of Ontario (PEO No. 100088418).
2. My relevant experience includes Project Director for detailed engineering for several major projects such as the Meliadine project, LaRonde extension, Casa Berardi, Westwood, Opinaca exploration and production shafts, Pinos Altos, etc. I also have expertise in manufacturing.
3. I have read the definition of “qualified person” set out in the NI 43-101 – Standards of Disclosure for Mineral Projects (“NI 43-101”) and certify that, by reason of my education, affiliation with a professional association, and past relevant work experience, I fulfill the requirements to be a qualified person for the purposes of NI 43-101.
4. I am independent of the issuer applying all the tests in Section 1.5 of NI 43-101.
5. I am responsible for the contribution of preparation for Sections 16.6.1, 16.6.3, and 18.8. I am also responsible for contributions to Chapters 1, 21, 25, 26, and 27 of the Technical Report.
6. I personally did not visit the property that is the subject of the Technical Report.
7. I have had no prior involvement with the property that is the subject of the Technical Report.
8. I have read NI 43-101 and the sections of the Technical Report for which I am responsible have been prepared in compliance with NI 43-101.
9. As at the effective date of the Technical Report, to the best of my knowledge, information and belief, the sections of the Technical Report for which I am responsible contain all scientific and technical information that is required to be disclosed to make the portions of the Technical Report for which I am responsible not misleading.

Dated this 30<sup>th</sup> day of October, 2017

*“Signed and sealed”*

---

Stéphane Lance, P. Eng.

## CERTIFICATE OF QUALIFIED PERSON

### Claire Hayek, P. Eng, MBA

This certificate applies to the **NI 43-101 Technical Report for the Horne 5 Gold Project Feasibility Study prepared for Falco Resources Ltd.** issued on October 30, 2017 (the "Technical Report") and effective October 5, 2017.

I, Claire Hayek, P. Eng., MBA, as a co-author of the Technical Report, do hereby certify that:

1. I am a metallurgical engineer and project director with WSP Canada Inc. located at 1600, René-Levesque West, 16<sup>th</sup> floor, Montréal, Québec, Canada.
2. I am a graduate of McGill University in Montréal, Québec, Canada in 1997 with a bachelor of engineering in Metallurgical Engineering and a graduate of McGill-HEC Montréal, Québec, Canada in 2015 with an Executive Master's degree in Business Administration.
3. I am a member in good standing of the Order of Engineers of Québec (OIQ No. 5020255).
4. My relevant experience includes mineral processing and tailings processing in the mining and environmental sectors involving crushing and grinding, gravity separation, classification, dewatering, pumping and waste management of iron ore and gold.
5. I have read the definition of "qualified person" set out in the NI 43-101 – Standards of Disclosure for Mineral Projects ("NI 43-101") and certify that, by reason of my education, affiliation with a professional association, and past relevant work experience, I fulfill the requirements to be a qualified person for the purposes of NI 43-101.
6. I am independent of the issuer applying all the tests in Section 1.5 of NI 43-101.
7. I am responsible for the preparation of Sections 13.8 and 17.2.13. I am also responsible for contributions to Chapters 1, 21, 25, 26, and 27 of the Technical Report.
8. I personally did not visit the property that is the subject to the Technical Report.
9. I have had no prior involvement with the property that is the subject of the Technical Report.
10. I have read NI 43-101 and the sections of the Technical Report for which I am responsible have been prepared in compliance with NI 43-101.
11. As at the effective date of the Technical Report, to the best of my knowledge, information and belief, the sections of the Technical Report for which I am responsible contain all scientific and technical information that is required to be disclosed to make the portions of the Technical Report for which I am responsible not misleading.

Dated this 30<sup>th</sup> day of October, 2017

*"Signed and sealed"*

---

Claire Hayek, P. Eng., MBA

## CERTIFICATE OF QUALIFIED PERSON

**Dominick Turgeon, P. Eng.**

This certificate applies to the **NI 43-101 Technical Report for the Horne 5 Gold Project Feasibility Study prepared for Falco Resources Ltd.** issued on October 30, 2017 (the "Technical Report") and effective October 5, 2017.

I, Dominick Turgeon, P. Eng., as a co-author of the Technical Report, do hereby certify that:

1. I am a Director – Mechanical – Mining Infrastructures - Québec with WSP Canada Inc. located at 1075, 3<sup>e</sup> Avenue Est, Val-d'Or, Québec, Canada.
2. I am a graduate of École de technologie supérieure, Université du Québec à Montréal, Québec, Canada, with a Bachelor's Degree in Mechanical engineering, 2003 and Collège de l'Outaouais, Gatineau, Québec, Canada, with a Diploma of College Studies, mechanical technology in 1997.
3. I am a member in good standing of the Ordre des Ingénieurs du Québec (OIQ No. 131791), Professional Engineers of Ontario (PEO No. 100134584), Association of Professional Engineers of Nova Scotia (APENS No. 8646) and Association of Professional Engineers and Geoscientist of the province of Manitoba (APEGM No. 34586).
4. My relevant experience includes: Kittila Mine, ore hoisting infrastructures economical study. Responsible for the mechanical, structural and concrete disciplines for the ore handling system including the extraction infrastructures (crusher, rockbreaker, conveyor, bin loading, etc.). Project Manager for detailed engineering of Casa Berardi Mine ore handling system including conveyors, grizzly and rockbreaker station. Project manager for detailed engineering for Kidd Mining Loading station, rockbreaker station and Project Manager for the crushing system replacement of Island Gold Mine, Laronde Deep & Goldex Mine.
5. I have read the definition of "qualified person" set out in the NI 43-101 – Standards of Disclosure for Mineral Projects ("NI 43-101") and certify that, by reason of my education, affiliation with a professional association, and past relevant work experience, I fulfill the requirements to be a qualified person for the purposes of NI 43-101.
6. I am independent of the issuer applying all the tests in Section 1.5 of NI 43-101.
7. I am responsible for the preparation of Sections 21.1.3.1.3 and 21.1.4.1. I am also responsible for contributions to Chapters 1, 21, 25, 26, and 27 of the Technical Report.
8. I personally did not visit the property that is the subject of the Technical Report.
9. I have had no prior involvement with the property that is the subject of the Technical Report.
10. I have read NI 43-101 and the sections of the Technical Report for which I am responsible have been prepared in compliance with NI 43-101.
11. As at the effective date of the Technical Report, to the best of my knowledge, information and belief, the sections of the Technical Report for which I am responsible contain all scientific and technical information that is required to be disclosed to make the portions of the Technical Report for which I am responsible not misleading.

Dated this 30<sup>th</sup> day of October, 2017

*"Signed and sealed"*

---

Dominick Turgeon, P. Eng.

## CERTIFICATE OF QUALIFIED PERSON

**Luc Gaulin, P. Eng., MBA**

This certificate applies to the **NI 43-101 Technical Report for the Horne 5 Gold Project Feasibility Study prepared for Falco Resources Ltd.** issued on October 30, 2017 (the "Technical Report") and effective October 5, 2017.

I, Luc Gaulin, P. Eng., MBA, as a co-author of the technical report do hereby certify that:

1. I am a Project Manager with SNC-Lavalin Stavibel Inc. located at 1271, 7th Street, Val-d'Or Québec, Canada.
2. I am a graduate of Laval University, Québec-City, Canada with a B.Sc.A in Mechanical Engineering in 1993. I obtained a Master of Business Administration (MBA) degree from the University of Québec at Montréal (UQAM), Québec, Canada in 1998. I have practiced my profession continuously since my graduation.
3. I am a registered member in good standing of the Order of Engineers of Québec (OIQ No. 111185) and of the Canadian Institute of Mining, Metallurgy and Petroleum (Member No. 145808).
4. My relevant experience includes a total of twenty-four (24) years of work as an engineer. My mining project expertise has mostly been acquired in the Raglan, Canadian Malartic, Eleonore and Renard mine. I have been a consulting engineer for SNC-Lavalin Stavibel Inc. since November 2006.
5. I have read the definition of "qualified person" set out in the NI 43-101 – Standards of Disclosure for Mineral Projects ("NI 43-101") and certify that, by reason of my education, affiliation with a professional association, and past relevant work experience, I fulfill the requirements to be a qualified person for the purposes of NI 43-101.
6. I am independent of the issuer applying all the tests in Section 1.5 of NI 43-101.
7. I am responsible for the preparation of Surface Infrastructures Sections 18.5, 18.6, 18.10 to 18.13 and 18.18 to 18.20. I am also responsible for the relevant portions of Chapters 1, 21, 25, 26, and 27 of the Technical Report.
8. I personally visited the property that is the subject of the Technical Report on August 16, 2016 and November 10, 2016.
9. I have had no prior involvement with the property that is the subject of the Technical Report.
10. I have read NI 43-101 and the sections of the Technical Report for which I am responsible have been prepared in compliance with NI 43-101.
11. As at the effective date of the Technical Report, to the best of my knowledge, information and belief, the sections of the Technical Report for which I am responsible contain all scientific and technical information that is required to be disclosed to make the portions of the Technical Report for which I am responsible not misleading.

Dated this 30<sup>th</sup> day of October, 2017

*"Signed and sealed"*

---

Luc Gaulin, Eng., MBA

## CERTIFICATE OF QUALIFIED PERSON

**Yves Vallières, P. Eng.**

This certificate applies to the **NI 43-101 Technical Report for the Horne 5 Gold Project Feasibility Study prepared for Falco Resources Ltd.** issued on October 30, 2017 (the "Technical Report") and effective October 5, 2017.

I, Yves Vallières, P. Eng., as a co-author of the Technical Report, do hereby certify that:

1. I am a Railway Engineer and President with Ingénierie RIVVAL Inc., located at 422, 19th Avenue, Deux-Montagnes, Québec, Canada.
2. I am 1986 graduate of the University of Sherbrooke, Québec, Canada, as a Bachelor in Applied Sciences Civil Engineering.
3. I am a member in good standing of the Order of Engineers of Québec (OIQ No 42706).
4. My relevant experience includes 22 years as Railway Engineer/Specialist with the Canadian Pacific Railway, two years as Director Track & Infrastructure with Genivar, four years as Director Track & Infrastructure with Les Consultants Canarail, three years as Director Track & Infrastructure with Groupe SMi, one and a half years as Director, Track Infrastructure with STV Canada Consulting Inc. and, most recently, President of Ingénierie RIVVAL Inc. for the past seven years.
5. I have read the definition of "qualified person" set out in the NI 43-101 – Standards of Disclosure for Mineral Projects ("NI 43-101") and certify that, by reason of my education, affiliation with a professional association, and past relevant work experience, I fulfill the requirements to be a qualified person for the purposes of NI 43-101.
6. I am independent of the issuer applying all the tests in Section 1.5 of NI 43-101.
7. I am responsible for the preparation of Section 18.14. I am also responsible for contributions to Chapters 1, 21, 25, 26, and 27 of the Technical Report.
8. I personally did not visit the property that is the subject of the Technical Report.
9. I have had no prior involvement with the property that is the subject of the Technical Report.
10. I have read NI 43-101 and the sections of the Technical Report for which I am responsible have been prepared in compliance with NI 43-101.
11. As at the effective date of the Technical Report, to the best of my knowledge, information and belief, the sections of the Technical Report for which I am responsible contain all scientific and technical information that is required to be disclosed to make the portions of the Technical Report for which I am responsible not misleading.

Dated this 30<sup>th</sup> day of October, 2017

*"Signed and sealed"*

---

Yves Vallières, P. Eng.

## TABLE OF CONTENTS

<b>1. SUMMARY .....</b>	<b>1-1</b>
1.1 Key Project Outcomes .....	1-4
1.2 Property Description, Location and Access .....	1-5
1.3 Land Tenure, License Agreements and Royalties .....	1-5
1.4 Property History.....	1-7
1.5 Sample Preparation, Analyses and Security.....	1-7
1.6 Data Verification .....	1-7
1.7 Mineral Processing and Metallurgical Testing .....	1-8
1.8 Mineral Resource Estimate .....	1-9
1.9 Mineral Reserve Estimate .....	1-12
1.10 Mining Methods .....	1-12
1.10.1 Geotechnical and Hydrogeological Considerations.....	1-13
1.10.2 Mine Design .....	1-14
1.10.3 Mine Dewatering and Rehabilitation.....	1-16
1.10.4 Mine Services.....	1-16
1.10.5 Cemented Paste Backfill .....	1-17
1.10.6 Production Plan.....	1-18
1.10.7 Underground High Density Sludge, Slurry Tailings and Paste Backfill Distribution.....	1-18
1.10.8 Mine Equipment and Personnel .....	1-19
1.11 Process Plant .....	1-19
1.12 Project Infrastructure .....	1-21
1.12.1 Geotechnical Studies .....	1-21
1.12.2 Horne 5 Mining Complex.....	1-22
1.12.3 Water Treatment .....	1-26
1.12.4 Tailings Management Facility.....	1-27
1.13 Environmental and Permitting .....	1-28
1.13.1 Studies and Permitting .....	1-28
1.13.2 Waste and Water Management.....	1-28
1.13.3 Project Closure.....	1-29
1.14 Market Studies and Contracts.....	1-29
1.14.1 Metal Pricing .....	1-29
1.14.2 Concentrate Logistics.....	1-29
1.14.3 NSR Calculations .....	1-30
1.14.4 Contracts.....	1-30
1.15 Capital Cost Estimate.....	1-30



1.16	Operating Cost Estimate .....	1-33
1.17	Project Economics .....	1-35
1.18	Project Organization and Schedule .....	1-39
1.19	Interpretations and Conclusions.....	1-41
1.19.1	Risks and Opportunities .....	1-41
1.20	Recommendations .....	1-42
<b>2.</b>	<b>INTRODUCTION.....</b>	<b>2-1</b>
2.1	Falco Resources Ltd. ....	2-1
2.2	Basis of Technical Report .....	2-2
2.3	Report Responsibility and Qualified Persons.....	2-4
2.4	Effective Dates and Declaration.....	2-8
2.5	Sources of Information .....	2-9
2.5.1	General .....	2-9
2.5.2	BBA.....	2-10
2.5.3	SNC-Lavalin.....	2-10
2.5.4	InnovExplo .....	2-11
2.5.5	Golder .....	2-11
2.5.6	WSP.....	2-11
2.6	Site Visits.....	2-12
2.7	Currency, Units of Measure, and Calculations.....	2-13
2.8	Acknowledgements .....	2-13
<b>3.</b>	<b>RELIANCE ON OTHER EXPERTS .....</b>	<b>3-1</b>
3.1	Introduction.....	3-1
3.2	Mineral Tenure and Surface Rights .....	3-1
3.3	Taxation.....	3-2
3.4	Commodity Pricing and Markets .....	3-2
<b>4.</b>	<b>PROPERTY DESCRIPTION AND LOCATION .....</b>	<b>4-1</b>
4.1	Location.....	4-1
4.2	Mining Rights in the Province of Québec.....	4-1
4.2.1	The Claim.....	4-2
4.2.2	The Mining Lease.....	4-4
4.2.3	The Mining Concession.....	4-4
4.2.4	Mining Titles of the Property.....	4-4
4.2.5	Horne Deposit Owner History.....	4-8
4.2.6	Agreements and Encumbrance.....	4-8
4.2.7	Royalties .....	4-11

4.3	Surface Rights and Option Agreements .....	4-11
4.4	Communication and Consultation with the Community .....	4-12
4.5	Permits, Infrastructure and Environmental Liabilities .....	4-12
4.5.1	Permits .....	4-12
4.5.2	Enhanced Role of Municipal Authorities .....	4-13
4.5.3	Infrastructure and Environmental Liabilities .....	4-13
4.6	Comments on Chapter 4 .....	4-14
<b>5.</b>	<b>ACCESSIBILITY, CLIMATE, LOCAL RESOURCES, INFRASTRUCTURE AND PHYSIOGRAPHY</b> .....	<b>5-1</b>
5.1	Accessibility .....	5-1
5.2	Local Resources and Infrastructure .....	5-1
5.3	Climate .....	5-3
5.4	Physiography .....	5-3
<b>6.</b>	<b>HISTORY</b> .....	<b>6-1</b>
6.1	Noranda Period (1920 - 2011) .....	6-1
6.2	Alexis Minerals Corporation Period (2011 - 2012) .....	6-8
6.3	Falco Period (2012 - 2014) .....	6-8
6.4	Preliminary Economic Assessment Summary (2016).....	6-18
6.4.1	Mining Methods .....	6-18
6.4.2	Capital and Operating Costs .....	6-19
6.4.3	Interpretation and Conclusions.....	6-19
6.4.4	Recommendations .....	6-19
<b>7.</b>	<b>GEOLOGICAL SETTING AND MINERALIZATION</b> .....	<b>7-1</b>
7.1	Regional Geology.....	7-1
7.1.1	Abitibi Terrane (Abitibi Sub-province).....	7-1
7.1.2	New Abitibi Greenstone Belt Subdivisions .....	7-2
7.1.3	Noranda Camp.....	7-4
7.2	Property Geology .....	7-6
7.2.1	Central Mine Sequence.....	7-6
7.2.2	Horne Block Sequence .....	7-7
7.3	Mineralization .....	7-15
7.3.1	Upper and Lower H Orebodies.....	7-15
7.3.2	Horne 5 Deposit .....	7-15
7.3.3	Identification of Gold Mineralization .....	7-26
7.3.4	Lithostructural Model.....	7-33

<b>8. DEPOSIT TYPES</b>	<b>8-1</b>
8.1 Volcanogenic Massive Sulphide Deposits	8-1
8.2 Gold-Rich Volcanogenic Massive Sulphide Deposits	8-3
8.3 Geological Characteristics of Au-rich VMS Deposits	8-4
<b>9. EXPLORATION</b>	<b>9-1</b>
9.1 Assay Results from Historical Metallurgical Tests	9-1
9.2 Additional Historical Drilling Data	9-2
9.3 Assay Results from Historical Underground Channel Samples	9-5
9.4 Geological Information from Historical Underground Drill Holes	9-10
9.4.1 Data Acquisition	9-11
9.4.2 Data Compilation	9-14
9.4.3 3D Modelling for Lithostructural Model	9-16
<b>10. DRILLING</b>	<b>10-1</b>
10.1 Overview	10-1
10.2 Confirmation / Metallurgical Drilling Program	10-1
10.2.1 Assay Results	10-3
10.2.2 Lithological Units	10-5
10.2.3 Alteration Facies	10-5
10.2.4 Structural Features	10-5
10.2.5 Mineralized Facies	10-6
10.2.6 Litho geochemistry	10-6
10.3 Horne 5 West Program	10-6
10.3.1 Assay Results	10-8
10.4 Quemont Extension Program	10-11
<b>11. SAMPLE PREPARATION, ANALYSES, AND SECURITY</b>	<b>11-1</b>
11.1 Laboratory Accreditation and Certification	11-1
11.2 Sample Preparation	11-1
11.3 Sample Preparation (Non-mineralized Zones)	11-2
11.4 Sample Preparation (Mineralized Zones)	11-2
11.5 Analytical Methods	11-3
11.6 Falco QA/QC Results for the 2015–2016 Diamond Drilling Programs	11-3
11.6.1 Blanks	11-3
11.6.2 Certified Reference Materials (Standards)	11-4
11.6.3 Duplicates	11-7
11.7 Conclusions	11-19

<b>12. DATA VERIFICATION .....</b>	<b>12-1</b>
12.1 Historical Underground Drill Hole Database .....	12-3
12.2 First Compilation Phase .....	12-3
12.3 Resampling .....	12-4
12.4 Second Compilation Phase .....	12-9
12.5 Historical Underground Drill Hole Assays .....	12-9
12.6 Comments on the Historical Underground Drill Hole Database .....	12-15
12.7 Historical Underground Channel Sample Database .....	12-17
12.8 2015/2016 Confirmation and Exploration Drilling Program .....	12-22
12.9 Relation between Silver Content and Specific Gravity .....	12-28
12.10 Site Visit .....	12-29
12.11 Remaining Half-Core Samples from 2015 Drilling Program .....	12-30
12.12 Conclusions .....	12-30
<b>13. MINERAL PROCESSING AND METALLURGICAL TESTING .....</b>	<b>13-1</b>
13.1 PEA Study Metallurgical Testwork .....	13-1
13.1.1 PEA Sample Selection and Compositing .....	13-2
13.1.2 Composite Characterization .....	13-5
13.2 Feasibility Study Testwork .....	13-6
13.2.1 FS Sample Selection and Compositing .....	13-7
13.2.2 FS Samples Head Assays .....	13-9
13.2.3 Lithology .....	13-11
13.2.4 Head Samples Mineralogy .....	13-18
13.3 Comminution Testwork .....	13-22
13.4 Flotation Testwork .....	13-33
13.4.1 Bulk Sulphide Flotation .....	13-34
13.4.2 Selective Flotation .....	13-34
13.4.3 Metallurgical Projections for the Flotation Circuits .....	13-41
13.5 Leaching Testwork .....	13-61
13.5.1 Program Overview .....	13-61
13.5.2 Pyrite Concentrate Leaching Test Results .....	13-67
13.5.3 Pyrite Flotation Tailings Leaching Results .....	13-76
13.5.4 Fine Regrinding Testwork .....	13-80
13.5.5 Oxygen Uptake Tests .....	13-82
13.6 Cyanide Destruction Testwork .....	13-83

13.7	Thickening, Filtration and Rheology Testwork .....	13-88
13.7.1	Thickening.....	13-88
13.7.2	Concentrate Filtration.....	13-89
13.7.3	Slurry Rheology.....	13-92
13.8	Paste Backfill Filtration Testing .....	13-97
13.8.1	Filtration Testing by Golder .....	13-97
13.8.2	Filtration Testing by Suppliers .....	13-97
<b>14.</b>	<b>MINERAL RESOURCE ESTIMATES .....</b>	<b>14-1</b>
14.1	Methodology.....	14-1
14.1.1	Drill Hole Database .....	14-2
14.1.2	Underground Channel Database.....	14-5
14.1.3	Developments and Mined-out Voids .....	14-7
14.1.4	Interpretation of Mineralized Zones.....	14-8
14.1.5	High Grade Capping .....	14-11
14.1.6	Compositing .....	14-17
14.1.7	Variography and Search Ellipsoids .....	14-21
14.1.8	Block Model Geometry.....	14-25
14.1.9	Mineralized Zone Block Model .....	14-26
14.1.10	Grade Interpolation .....	14-27
14.1.11	Specific Gravity .....	14-29
14.1.12	Block Model Validation.....	14-30
14.1.13	NSR and Cut-off.....	14-37
14.2	Mineral Resource Classification.....	14-38
14.2.1	Horne 5 Deposit Classification .....	14-39
14.3	Mineral Resource Estimation .....	14-43
14.4	Mineral Resource Estimate Evolution .....	14-47
<b>15.</b>	<b>MINERAL RESERVE ESTIMATES .....</b>	<b>15-1</b>
15.1	Factors that May Affect the Mineral Reserves .....	15-1
15.2	Underground Estimates .....	15-2
15.3	Dilution Factor Calculation .....	15-3
15.4	NSR Cut-off calculation.....	15-4
15.5	Statement of Mineral Reserves.....	15-4
<b>16.</b>	<b>MINING METHODS .....</b>	<b>16-1</b>
16.1	Introduction.....	16-2
16.2	Rock Engineering.....	16-3
16.2.1	Considerations .....	16-3

16.2.2	Rock Mass Characterization .....	16-6
16.2.3	Proximity between New and Historical Mine Workings .....	16-12
16.2.4	Near Surface Crown Pillars .....	16-13
16.2.5	Mining Sequence .....	16-13
16.2.6	Stope Dimensions .....	16-17
16.2.7	Sill Pillars .....	16-17
16.2.8	Infrastructure Proximity Relative to Orebody .....	16-18
16.2.9	Ground Support .....	16-20
16.2.10	Backfill Strength Requirement .....	16-26
16.2.11	Rock Mass Monitoring Needs .....	16-27
16.3	Mine Hydrogeology .....	16-28
16.3.1	Dewatering Flow Rate Estimate .....	16-30
16.4	Mine Dewatering .....	16-32
16.4.1	Old Workings Interconnections .....	16-32
16.4.2	Void and Water Volume Estimation in Historical Mines .....	16-35
16.4.3	Dewatering Installations and Infrastructure .....	16-47
16.4.4	Pre-dewatering .....	16-51
16.4.5	Dewatering Steps .....	16-53
16.4.6	Dewatering Schedule .....	16-61
16.5	Mine Services .....	16-63
16.5.1	Electrical Distribution .....	16-63
16.5.2	Mine Automation and Monitoring Systems .....	16-68
16.5.3	Fuel Distribution Network .....	16-70
16.5.4	Permanent Mine Pumping Network .....	16-72
16.5.5	Ventilation Network .....	16-79
16.6	Mine Design .....	16-101
16.6.1	Quemont No. 2 Shaft .....	16-101
16.6.2	Shaft Access .....	16-104
16.6.3	Ore Hoisting System .....	16-107
16.6.4	Main Infrastructure .....	16-108
16.6.5	Permanent Ore Handling System .....	16-115
16.6.6	Development Schedule .....	16-125
16.7	Mining Method .....	16-128
16.7.1	Transverse Long Hole Mining Method Description .....	16-128
16.7.2	Stope Design .....	16-130
16.7.3	Drilling and Blasting Pattern .....	16-131
16.7.4	Production Rate .....	16-144

16.7.5	Mining Sequencing: Panels, Primary and Secondary .....	16-148
16.7.6	Production Plan.....	16-150
16.8	Cemented Paste Backfill.....	16-152
16.8.1	Paste Plant Capacity.....	16-152
16.8.2	Material Testing.....	16-153
16.8.3	Paste Backfill Underground Distribution System (“UDS”).....	16-156
16.8.4	Barricades.....	16-165
16.9	Underground High Density Sludge (“HDS”) and Slurry Tailings Disposal .....	16-165
16.9.1	HDS Underground Disposal.....	16-165
16.9.2	Tailings Slurry Disposal.....	16-171
16.9.3	Quemont and Horne Barricades.....	16-177
16.9.4	Self-heating.....	16-183
16.9.5	Remote Plugs.....	16-184
16.10	Underground Mine Equipment .....	16-185
16.10.1	Working Hours and Equipment Performance Table.....	16-185
16.10.2	Production Requirements.....	16-186
16.10.3	Mine Equipment List.....	16-186
16.11	Mine Personnel .....	16-188
<b>17.</b>	<b>RECOVERY METHODS .....</b>	<b>17-1</b>
17.1	Processing Plant Design Criteria .....	17-5
17.1.1	Throughput Capability per Area .....	17-5
17.1.2	Design Feed Grades .....	17-5
17.2	Process Plant Facilities Description .....	17-8
17.2.1	Crushing.....	17-8
17.2.2	Stockpile Reclaim.....	17-8
17.2.3	Grinding .....	17-8
17.2.4	Flotation .....	17-12
17.2.5	Concentrate Dewatering .....	17-18
17.2.6	Pre-leach Thickening .....	17-23
17.2.7	Pyrite Concentrate Regrinding Circuit.....	17-24
17.2.8	Cyanidation Circuits .....	17-27
17.2.9	Carbon-in-Pulp Circuits.....	17-29
17.2.10	Pre-detoxification Thickening .....	17-31
17.2.11	Gold Recovery Circuits .....	17-33
17.2.12	Cyanide Destruction Circuits.....	17-36
17.2.13	Paste Backfill Circuit .....	17-37
17.2.14	Reagent Systems.....	17-38

17.2.15	Process Plant Control System.....	17-43
17.2.16	Process Plant Support Services.....	17-47
17.3	Energy, Water and Consumable Requirements .....	17-47
17.3.1	Process Plant Electrical Distribution.....	17-47
17.3.2	Energy Requirements .....	17-47
17.3.3	Plant Water Systems.....	17-49
17.3.4	Air Systems.....	17-51
17.3.5	Consumable Requirements.....	17-51
17.4	Process Plant Personnel.....	17-53
17.5	Comments on Chapter 17 .....	17-54
<b>18.</b>	<b>PROJECT INFRASTRUCTURE .....</b>	<b>18-1</b>
18.1	General.....	18-2
18.2	Horne 5 Mining Complex Site Arrangement .....	18-4
18.3	Site Preparation .....	18-4
18.4	Geotechnical Studies .....	18-5
18.4.1	Stratigraphy.....	18-5
18.4.2	Proposed Structures and Types of Foundations .....	18-7
18.4.3	Foundation Design Recommendations .....	18-7
18.4.4	Groundwater Control.....	18-7
18.5	Site Access Road and Control .....	18-8
18.6	Light Vehicle Roads .....	18-8
18.7	Electrical Infrastructure .....	18-9
18.7.1	Power Supply.....	18-9
18.7.2	Power Demand .....	18-10
18.7.3	Emergency Power.....	18-11
18.8	Hoist Room and Headframe.....	18-12
18.8.1	Hoisting System .....	18-13
18.8.2	Hoist Building.....	18-15
18.8.3	Underground Distribution .....	18-15
18.8.4	Headframe .....	18-15
18.8.5	Surface Material Handling.....	18-16
18.9	Process Plant .....	18-17
18.10	Warehouse and Service Building.....	18-18
18.11	Mine Office and Dry Building.....	18-19
18.12	First Aid / Emergency Services .....	18-20
18.13	Administration Building.....	18-20



18.14 Railways .....	18-21
18.15 Communications and IT .....	18-21
18.16 Bulk Explosive Storage .....	18-22
18.17 Fuel Storage and Delivery.....	18-22
18.18 Site Utilities.....	18-23
18.18.1 Fire Water and Distribution System.....	18-23
18.18.2 Potable Water .....	18-24
18.18.3 Sewage Treatment.....	18-24
18.18.4 Natural Gas .....	18-25
18.19 Municipal Infrastructure.....	18-26
18.20 Site Infrastructure Relocation.....	18-26
18.20.1 Lamothe, Div. de Sintra Inc.....	18-26
18.20.2 Centre de Formation Quemont.....	18-26
18.21 Tailings Management Facility Infrastructure .....	18-27
18.22 Surface Water Management .....	18-30
18.22.1 Overall Water Management .....	18-30
18.22.2 Horne 5 Mining Complex.....	18-30
18.22.3 Tailings Management Facility Site.....	18-32
18.23 Water Treatment Infrastructure .....	18-33
18.23.1 Water Treatment Strategy.....	18-34
18.23.2 Water Treatment Facilities .....	18-36
18.23.3 Mine Closure Water Treatment .....	18-38
18.23.4 Available Water Quality and Flow Data.....	18-40
18.23.5 Water Treatment Technology.....	18-45
18.23.6 Sludge Handling Strategy .....	18-48
18.24 Tailings Pipelines .....	18-49
18.24.1 Tailings Pipeline Route .....	18-49
18.24.2 Tailings Pipeline Design .....	18-50
18.24.3 Tailings Pipeline Operation .....	18-50
18.25 Reclaim Water Pipeline.....	18-51
18.26 Fresh Water Infrastructure .....	18-51
18.26.1 Fresh Water Pump House and Pipeline .....	18-51
<b>19. MARKET STUDIES AND CONTRACTS.....</b>	<b>19-1</b>
19.1 Base Metal Concentrate Sales.....	19-1
19.1.1 Zinc Concentrate.....	19-1
19.1.2 Copper Concentrate.....	19-3

19.2	Gold Doré Sales .....	19-4
19.3	Calculation of Net Metal Payment from Product Buyers.....	19-5
19.4	Net Treatment and Refining Charges .....	19-6
19.5	Sales and Marketing Contracts .....	19-6
19.6	Other Contracts .....	19-6
<b>20.</b>	<b>ENVIRONMENTAL STUDIES, PERMITTING, AND SOCIAL OR COMMUNITY IMPACT .....</b>	<b>20-1</b>
20.1	Environmental Studies .....	20-2
20.1.1	General Description .....	20-2
20.1.2	Physical Environment.....	20-4
20.1.3	Biological Environment.....	20-16
20.2	Ore, Waste Rock, Tailings and Water Management Strategy .....	20-22
20.2.1	Production Schedule and Tailings Streams .....	20-22
20.2.2	Geochemical Assessment.....	20-23
20.2.3	Ore Management .....	20-27
20.2.4	Tailings and Waste Rock Management Strategy and Site Selection Process.....	20-27
20.2.5	Underground Tailings and Sludge Disposal – Groundwater Protection .....	20-31
20.2.6	Tailings Management Facility Site Description.....	20-33
20.2.7	Tailings Management Facility.....	20-40
20.2.8	Water Management.....	20-64
20.2.9	Site Water Quality Predictions.....	20-79
20.3	Regulatory Context .....	20-83
20.3.1	Environmental Impact Assessment Procedure.....	20-83
20.3.2	Laws and Regulations.....	20-86
20.3.3	Permitting Requirements.....	20-88
20.4	Social Considerations .....	20-91
20.4.1	Consultation Activities .....	20-91
20.4.2	Concerns Gathered through Consultation Activities.....	20-92
20.4.3	Social Components and Related Requirements.....	20-92
20.5	Mine Closure Requirements.....	20-98
20.6	Anticipated Environmental Issues .....	20-99
<b>21.</b>	<b>CAPITAL AND OPERATING COSTS .....</b>	<b>21-1</b>
21.1	Capital Costs .....	21-1
21.1.1	Summary.....	21-1
21.1.2	Scope and Structure of Capital Cost Estimate .....	21-2
21.1.3	Preproduction Capital Costs.....	21-8
21.1.4	Sustaining Capital Cost.....	21-20

21.2	Operating Costs .....	21-26
21.2.1	Summary.....	21-26
21.2.2	Basis of Operating Cost Estimate .....	21-27
21.2.3	Underground Mining.....	21-28
21.2.4	Process Plant.....	21-31
21.2.5	Tailings, Water Treatment and Environment.....	21-37
21.2.6	General and Administration.....	21-38
21.2.7	Personnel Summary – All Areas .....	21-39
<b>22.</b>	<b>ECONOMIC ANALYSIS .....</b>	<b>22-1</b>
22.1	Assumptions and Basis.....	22-1
22.2	Gold Production .....	22-3
22.3	Capital and Sustaining Costs .....	22-4
22.4	Royalties.....	22-5
22.5	Taxation.....	22-5
22.6	Financial Analysis Summary .....	22-6
22.7	Production Costs .....	22-10
22.8	Sensitivity Analysis.....	22-11
<b>23.</b>	<b>ADJACENT PROPERTIES.....</b>	<b>23-1</b>
23.1	Horne Mine.....	23-2
23.2	Chadbourne Mine.....	23-2
23.3	Quemont Mine.....	23-4
23.4	Joliet Mine .....	23-5
23.5	Don Rouyn Mine .....	23-5
23.6	Horne West Occurrence.....	23-5
23.7	ECU Silver Mining Inc. Property.....	23-6
23.8	Visible Gold Mines Inc. Property.....	23-7
23.9	NSR Resources Inc. Property .....	23-7
23.10	Comments on Chapter 23 .....	23-8
<b>24.</b>	<b>OTHER RELEVANT DATA AND INFORMATION.....</b>	<b>24-1</b>
24.1	Project Organization.....	24-2
24.1.1	Engineering and Procurement.....	24-2
24.1.2	Construction Management.....	24-3
24.2	Project Execution Plan .....	24-5

<b>25. INTERPRETATION AND CONCLUSIONS .....</b>	<b>25-1</b>
25.1 Overview .....	25-2
25.2 Land Tenure, License Agreements and Royalties .....	25-2
25.3 Data Verification .....	25-4
25.4 Mineral Resource Estimate .....	25-6
25.5 Mineral Reserve Estimate .....	25-9
25.6 Mining Methods .....	25-9
25.6.1 Overview .....	25-10
25.6.2 Geotechnical and Hydrogeological Considerations .....	25-11
25.6.3 Mine Design .....	25-12
25.6.4 Mine Dewatering and Rehabilitation .....	25-13
25.6.5 Mine Services .....	25-14
25.6.6 Cemented Paste Backfill .....	25-14
25.6.7 Production Plan .....	25-15
25.6.8 High Density Sludge (HDS) Distribution .....	25-16
25.6.9 Slurry Tailings Distribution .....	25-16
25.6.10 Mine Equipment and Personnel .....	25-16
25.7 Metallurgy and Processing .....	25-17
25.7.1 Metallurgical Testwork .....	25-17
25.7.2 Process Flowsheet .....	25-18
25.7.3 Metal Recovery Projections .....	25-18
25.7.4 Process Plant Personnel .....	25-19
25.8 Environment and Site Restoration .....	25-19
25.9 Waste Rock and Tailings Management .....	25-19
25.10 Water Management and Treatment .....	25-20
25.11 Infrastructure .....	25-22
25.12 Market Studies and Contracts .....	25-23
25.13 Capital Costs .....	25-24
25.14 Operating Costs .....	25-25
25.15 Indicative Economic Results .....	25-26
25.16 Execution Plan and Schedule .....	25-27
25.17 Project Risks and Opportunities .....	25-27

---

<b>26. RECOMMENDATIONS.....</b>	<b>26-1</b>
26.1 Summary.....	26-2
26.2 Additional Recommendations .....	26-3
26.2.1 Geology.....	26-3
26.2.2 Rock Engineering.....	26-3
26.2.3 Underground Mining.....	26-5
26.2.4 Paste Backfill Testwork and Plant Design.....	26-5
26.2.5 Metallurgical Testwork .....	26-5
26.2.6 Process Plant.....	26-6
26.2.7 Market Studies and Contracts.....	26-6
26.2.8 Tailings and Waste Rock Management.....	26-6
26.2.9 Tailings and Reclaim Water Pipelines.....	26-7
26.2.10 Water Management and Treatment .....	26-8
26.2.11 Water Quality .....	26-8
26.2.12 Mine Hydrogeology .....	26-9
26.2.13 Slurry Tailing Distribution .....	26-9
26.2.14 Environment and Permitting.....	26-9
<b>27. REFERENCES.....</b>	<b>27-1</b>
27.1 Geology and Mineral Resources.....	27-1
27.2 Underground Mining.....	27-9
27.3 Metallurgy and Process Plant .....	27-12
27.4 Infrastructure .....	27-13
27.5 Environment .....	27-14

## LIST OF TABLES

Table 1-1: Major contributors to the Feasibility Study.....	1-2
Table 1-2: Projected metallurgical recoveries and net payable values for Au, Ag, Cu and Zn .....	1-9
Table 1-3: Horne 5 mineral resource (July 25, 2017) .....	1-11
Table 1-4: Statement of mineral reserves (August 26, 2017) .....	1-12
Table 1-5: Power demand by area at the Horne 5 Mining Complex.....	1-22
Table 1-6: Project capital costs (preproduction and sustaining) .....	1-31
Table 1-7: Project operating costs .....	1-34
Table 1-8: Employee summary – all areas .....	1-35
Table 1-9: Financial analysis summary.....	1-36
Table 1-10: Key project activities (preliminary) .....	1-40
Table 2-1: Major study contributors .....	2-2
Table 2-2: Qualified Persons and areas of report responsibility .....	2-5
Table 4-1: Ownership of Horne 5 mining concessions (CM-156PTB and CM-243) .....	4-6
Table 6-1: Resource estimates <sup>(1)</sup> for the Horne 5 deposit .....	6-5
Table 6-2: Production from Horne 5 deposit.....	6-7
Table 6-3: 2014 Mineral resource estimate results (Inferred resources) at different NSR cut-offs .....	6-9
Table 6-4: Summary statistics of the confirmation drilling program .....	6-10
Table 6-5: Summary statistics of the Horne 5 Plus program .....	6-11
Table 6-6: March 2016 Mineral Resource Estimate for the Horne 5 deposit at \$65 NSR cut-off.....	6-13
Table 6-7: November 2016 Mineral Resource Estimate for the Horne 5 deposit at \$55 NSR cut-off .....	6-15
Table 9-1: Average grade of the historical metallurgical tests (1946 to 1963) .....	9-1
Table 9-2: Highlights of historical drill results as announced in Falco’s news release of July 10, 2014 ...	9-3
Table 9-3: Highlights of historical drill results as announced in Falco’s news release of August 22, 2014....	9-4
Table 9-4: Highlights of historical drill results as announced in Falco’s news release of November 6, 2014	9-5
Table 9-5: Gold: Raw channel assays – summary statistics .....	9-9
Table 9-6: Silver: Raw channel assays – summary statistics .....	9-9
Table 9-7: Copper: Raw channel assays – summary statistics .....	9-9
Table 9-8: Zinc: Raw channel assays – summary statistics .....	9-10

---

Table 10-1: Summary statistics of the confirmation drilling program.....	10-1
Table 10-2: Assay results from the 2016 confirmation drilling program .....	10-4
Table 10-3: Drilling statistics for the Horne 5 West exploration drilling program .....	10-6
Table 10-4: Assay results from the 2016 Horne 5 West drilling program .....	10-10
Table 10-5: Summary of drilling statistics of the Quemont Extension drilling program .....	10-11
Table 11-1: Standards used by Falco for the 2015 drilling program.....	11-5
Table 11-2: Standards used by Falco for the 2016 drilling program.....	11-5
Table 12-1: Horne 5 Deposit MRE evolution (2014-2016) – Datasets and interpretation .....	12-2
Table 12-2: Conversion of tonnage factor to specific gravity for pyrite and rhyolite .....	12-4
Table 12-3: Statistical overview of historical low-grade gold classes and their respective conversion method.....	12-10
Table 12-4: Assay results from the 2015/2016 confirmation and exploration drilling program for drill holes intersecting Horne 5 mineralization .....	12-24
Table 13-1: PEA comminution composites .....	13-4
Table 13-2: PEA flotation composites.....	13-4
Table 13-3: PEA grindability testwork composites head assays .....	13-5
Table 13-4: PEA flotation testwork composites head assays .....	13-5
Table 13-5: FS test plan for Phase 1 .....	13-6
Table 13-6: FS test plan for Phase 2 .....	13-7
Table 13-7: FS Phase 1 master composites preparation .....	13-7
Table 13-8: Sample sourcing of FS Phase 2 testwork program .....	13-8
Table 13-9: Phase 2 composite samples preparation .....	13-9
Table 13-10: Head assays for composite samples.....	13-10
Table 13-11: Grindability testwork composite lithology.....	13-16
Table 13-12: Flotation testwork composites zone and % sulphide.....	13-18
Table 13-13: Bulk mineralogy of flotation testwork composites.....	13-19
Table 13-14: Summary of SAGDesign and bond comminution test results from PEA study .....	13-23
Table 13-15: Summary of SAGDesign and bond comminution test results from FS testwork.....	13-23
Table 13-16: Grindability testwork statistics.....	13-25
Table 13-17: Grindability indices applicable to design and average ore .....	13-32
Table 13-18: Locked-cycle test results for composites MCA and MCB.....	13-35

Table 13-19: Locked-cycle test results for composites SS2021 to SS2025 – Phase 1.....	13-37
Table 13-20: Locked-cycle test results for composites H5-P2-C1 to H5-P2-C6 – Phase 2 .....	13-38
Table 13-21: Locked-cycle test results for composites H5-P2-C1 to H5-P2-C6 – Phase 3 .....	13-40
Table 13-22: Optimization of leaching conditions for pyrite flotation concentrates – PEA Phase .....	13-62
Table 13-23: Leaching conditions for pyrite flotation tailings – PEA Phase .....	13-63
Table 13-24: Leaching conditions for large-volume sample production of pyrite concentrate and pyrite flotation tailings – PEA Phase .....	13-63
Table 13-25: FS Optimization of leaching conditions for pyrite flotation concentrates – FS testwork...	13-65
Table 13-26: FS Optimization of leaching conditions for pyrite flotation tails – FS Phase 1 testwork...	13-66
Table 13-27: Results for pyrite concentrate leaching tests – PEA Phase .....	13-67
Table 13-28: Results for pyrite concentrate leaching tests – FS Phase 1 and Phase 2 .....	13-69
Table 13-29: Results for pyrite flotation tailings leaching tests.....	13-76
Table 13-30: Results for pyrite tailings leaching tests – FS Phase 1 and Phase 2 .....	13-77
Table 13-31: Oxygen uptake rate test conditions for reground bulk Py conc. SS2025 .....	13-82
Table 13-32: Oxygen uptake rate test conditions for SS2025 bulk Py flotation tails .....	13-82
Table 13-33: Oxygen consumption for pre-oxidation and leaching circuits, per Air Liquide.....	13-83
Table 13-34: PEA results of cyanide destruction tests with the INCO SO <sub>2</sub> /air technology.....	13-84
Table 13-35: Pre-oxidation and leaching conditions of reground pyrite conc. ....	13-85
Table 13-36: Leaching conditions of SS2025 bulk pyrite flotation tails .....	13-85
Table 13-37: Cyanide destruction test conditions .....	13-86
Table 13-38: Reground pyrite flotation concentrate CND test results .....	13-87
Table 13-39: Pyrite flotation tails CND test results .....	13-87
Table 13-40: List of tested materials vs sample sources for thickening, filtration and slurry rheology..	13-88
Table 13-41: Thickening test results .....	13-89
Table 13-42: Pressure filtration sizing parameters from testwork.....	13-90
Table 13-43: Pressure filtration sizing data for copper concentrate samples.....	13-90
Table 13-44: Pressure filtration sizing data for zinc concentrate .....	13-91
Table 13-45: Lab pressure filtration results.....	13-98
Table 13-46: Vacuum filtration results .....	13-99
Table 14-1: Gold – DDH raw assay statistics .....	14-11
Table 14-2: Silver – DDH raw assay statistics .....	14-12



Table 14-3: Silver – Metallurgical test raw assay statistics.....	14-12
Table 14-4: Copper – DDH raw assay statistics .....	14-13
Table 14-5: Zinc – DDH raw assay statistics .....	14-13
Table 14-6: Specific gravity – DDH values statistics .....	14-14
Table 14-7: Gold – 3 m composite statistics.....	14-18
Table 14-8: Silver – 3 m composite statistics – all DDH .....	14-19
Table 14-9: Silver – 3 m composite statistics – metallurgical tests.....	14-19
Table 14-10: Silver – 3 m composite statistics – underground DDH .....	14-19
Table 14-11: Copper – 3 m composite statistics.....	14-20
Table 14-12: Zinc – 3 m composite statistics.....	14-20
Table 14-13: Specific gravity – 3 m composite statistics .....	14-20
Table 14-14: Gold – final search ellipsoid parameters .....	14-23
Table 14-15: Silver – final search ellipsoid parameters .....	14-24
Table 14-16: Copper – final search ellipsoid parameters .....	14-24
Table 14-17: Zinc – final search ellipsoid parameters .....	14-25
Table 14-18: Specific gravity – final search ellipsoid parameters.....	14-25
Table 14-19: Horne 5 deposit block model properties .....	14-26
Table 14-20: Horne 5 deposit block model and associated solids.....	14-26
Table 14-21: Statistics for gold by zone – cut assays, composites and block grades (0 g/t cut-off) .....	14-30
Table 14-22: Statistics for silver by zone – cut assays, composites and block grades (0 g/t cut-off)....	14-31
Table 14-23: Statistics for copper by zone – cut assays, composites and block grades (0 g/t cut-off) .	14-31
Table 14-24: Statistics for zinc by zone – cut assays, composites and block grades (0 g/t cut-off).....	14-31
Table 14-25: Breakdown of the underground NSR cut-off estimation for the Horne 5 deposit mineral resource estimate .....	14-38
Table 14-26: Horne 5 deposit mineral resource estimate at a \$55 NSR cut-off and sensitivity at other cut-off scenarios .....	14-44
Table 14-27: Horne 5 deposit mineral resource estimate by zone at a \$55 NSR cut-off .....	14-46
Table 14-28: Horne 5 deposit mineral resource estimate cut-off NSR sensitivity for gold equivalent...	14-46
Table 15-1: Stope dimension parameters – DSO inputs .....	15-2
Table 15-2: Sill pillar recovery.....	15-3
Table 15-3: Statement of mineral reserves.....	15-4

---

Table 16-1: Summary of number of laboratory rock strength tests <sup>(1)</sup> .....	16-7
Table 16-2: Summary of unconfined compressive strength per rock type (for intact failure type) .....	16-7
Table 16-3: Summary of Young’s Modulus and Poisson’s Ratio per rock type.....	16-8
Table 16-4: Summary of mean Hoek-Brown strength parameters per rock type (for intact failure type)	16-8
Table 16-5: Summary of stope dimensions .....	16-17
Table 16-6: Summary of sill pillar thicknesses.....	16-18
Table 16-7: Hydraulic conductivity value considered in the hydrogeological model.....	16-30
Table 16-8: Estimated dewatering flow rate – preproduction dewatering.....	16-31
Table 16-9: Estimated voids volumes for the Horne 5 Project.....	16-46
Table 16-10: Estimated water volumes for the Horne 5 Project dewatering .....	16-46
Table 16-11: Horne 5 Project airflow requirements .....	16-91
Table 16-12: Modeling inputs.....	16-99
Table 16-13: Underground main infrastructure listed by level .....	16-114
Table 16-14: Ore pass networks configuration .....	16-116
Table 16-15: Underground crushing system – Phase 1 .....	16-119
Table 16-16: Excavation dimensions .....	16-125
Table 16-17: Development quantities per year in metre .....	16-126
Table 16-18: Mine development schedule – Main milestones.....	16-127
Table 16-19: Maximum stope dimensions .....	16-128
Table 16-20: Mining cycle times.....	16-129
Table 16-21: Allowable vibration limits per frequency range, according to Directive 019 .....	16-132
Table 16-22: Maximum charge length per hole (165 mm diameter) depending on depth analysis for blast-induced vibration under 5 mm/s at surface (BBA, 2017).....	16-133
Table 16-23: Drilling and blasting pattern summary .....	16-144
Table 16-24: Hoisting parameters for loading station at level Q1180.....	16-147
Table 16-25: Hoisting parameters for loading station at level Q1851.....	16-147
Table 16-26: Mine plan and yearly tonnage distribution (diluted) .....	16-151
Table 16-27: Material properties .....	16-153
Table 16-28: Pressure filtration results .....	16-155
Table 16-29: Borehole summary for paste backfill distribution .....	16-159
Table 16-30: Piping to install at Horne 5 during the preproduction phase (first two years of mining) .	16-162

Table 16-31: Estimate of the flush water volumes per year.....	16-164
Table 16-32: HDS Production .....	16-166
Table 16-33: HDS thickened estimated water bleed .....	16-167
Table 16-34: Summary of friction losses for HDS at 35 wt%.....	16-168
Table 16-35: Borehole summary for HDS thickened slurry distribution at Donalda mine .....	16-168
Table 16-36: Borehole summary for HDS distribution at Quemont mine .....	16-170
Table 16-37: Slurry tailings production .....	16-171
Table 16-38: Slurry water bleed results (wt% solids).....	16-174
Table 16-39: Summary of parameters used in determining friction loss for 100 mm (4 in) system ....	16-174
Table 16-40: Summary of friction losses for slurry tailings options (100 mm (4 in) system) .....	16-175
Table 16-41: Borehole summary for slurry tailings distribution at Horne mine .....	16-175
Table 16-42: Barricade summary for slurry tailings distribution at Quemont mine .....	16-183
Table 16-43: Equipment performance .....	16-185
Table 16-44: Mining equipment for the Horne 5 Project.....	16-187
Table 16-45: Mine staff requirements – maintenance services and operations .....	16-188
Table 16-46: Hourly manpower requirements.....	16-189
Table 17-1: Proces plant selected design criteria .....	17-7
Table 17-2: Calculated grinding design parameters at design sulphide content .....	17-9
Table 17-3: Flotation stages design criteria and cell sizing .....	17-14
Table 17-4: Concentrate thickeners sizing criteria.....	17-19
Table 17-5: Concentrate filter sizing criteria .....	17-21
Table 17-6: Pre-leach thickeners sizing criteria .....	17-23
Table 17-7: Regrinding duty – effect of throughput on power demand and $P_{80}$ .....	17-25
Table 17-8: CIP circuit design criteria and operating parameters.....	17-29
Table 17-9: Pre-detoxification thickener sizing criteria .....	17-32
Table 17-10: Reagent mixing systems.....	17-38
Table 17-11: Indicated processing plant power demand, by area .....	17-48
Table 17-12: Estimated grinding media consumption.....	17-51
Table 17-13: Reagents - used and indicated consumption .....	17-52
Table 17-14: Process plant salaried manpower.....	17-53

---

Table 17-15: Process plant hourly manpower .....	17-54
Table 18-1: Power demand by area at the Horne 5 Mining Complex.....	18-11
Table 18-2: Process plant emergency power demand .....	18-11
Table 18-3: Mine hoist specifications .....	18-13
Table 18-4: Potable water requirements.....	18-24
Table 18-5: Sewage treatment requirements.....	18-25
Table 18-6: Natural gas requirements .....	18-25
Table 18-7: Dike elevations.....	18-28
Table 18-8: Mine pool water quality and volume estimates .....	18-40
Table 18-9: Four water qualities representing the mine pools* .....	18-41
Table 18-10: Water quality design basis for treatment – production without TMF .....	18-43
Table 18-11: Water quality design basis for treatment – production with TMF .....	18-44
Table 18-12: Water quality design basis for treatment – closure stage.....	18-45
Table 18-13: Expected sludge volume.....	18-48
Table 19-1: Metal prices used in derivation of the NSRs.....	19-1
Table 19-2: Indicated zinc concentrate assays.....	19-2
Table 19-3: Zinc concentrate sales terms used in derivation of the NSR.....	19-2
Table 19-4: Indicated copper concentrate assays .....	19-3
Table 19-5: Copper concentrate sales terms used in derivation of the NSR.....	19-4
Table 19-6: Doré terms used in derivation of the NSR .....	19-4
Table 19-7: Average LOM mass balance .....	19-5
Table 19-8: Calculation of net payable metal content in products .....	19-5
Table 19-9: Significant Project contracts .....	19-7
Table 20-1: Exceedance of water quality protection criteria in the Horne 5 Mining Complex vicinity .....	20-7
Table 20-2: Annual statistics of the AQI (number of days) .....	20-12
Table 20-3: Measured sound level and applicable noise criteria.....	20-14
Table 20-4: Average LOM mill rate and total tailings production .....	20-22
Table 20-5: Waste rock to be managed at surface .....	20-22
Table 20-6: Total tailings production rate per stream .....	20-23
Table 20-7: Summary of the ore, tailings and process water geochemistry characterization results....	20-25

---

Table 20-8: Summary of the waste rock geochemistry characterization results .....	20-27
Table 20-9: Tailings production and distribution strategy .....	20-28
Table 20-10: TMF Site – PFT and PCT specific gravity testing results and volume calculations .....	20-40
Table 20-11: Waste rock volume calculation for surface disposal.....	20-43
Table 20-12: TMF staged construction – crest elevations .....	20-45
Table 20-13: Tailings and water storage volumes – deposition plan.....	20-46
Table 20-14: Minimum FoS for slope stability in construction, operation, and transition phases – static assessment.....	20-54
Table 20-15: Minimum FoS for slope stability in construction, operation, and transition phases – seismic assessment.....	20-55
Table 20-16: Guidelines for water management.....	20-68
Table 20-17: Proposed operational design criteria for water management infrastructure.....	20-69
Table 20-18: Required modification on TMF water management infrastructure for closure .....	20-70
Table 20-19: Summary of preliminary water quality predictions, order-of-magnitude estimates.....	20-82
Table 20-20: Preliminary and non-exhaustive list of required permits and authorization .....	20-89
Table 20-21: List of the consultation activities carried out to date .....	20-91
Table 20-22: Mine site and related infrastructure anticipated issues or impacts.....	20-100
Table 21-1: Project preproduction capital cost summary.....	21-1
Table 21-2: Estimate responsibilities by WBS .....	21-3
Table 21-3: Exchange rate assumptions .....	21-4
Table 21-4: Heavy industrial labour rates (\$/hour) .....	21-5
Table 21-5: Light industrial labour rates (\$/hour).....	21-6
Table 21-6: Labour productivity factors.....	21-7
Table 21-7: Project preproduction capital cost summary.....	21-8
Table 21-8: General administration (Owner’s costs) preproduction capital cost summary .....	21-9
Table 21-9: Underground mine preproduction capital costs .....	21-10
Table 21-10: Headframe, hoist room and conveyor preproduction capital costs .....	21-11
Table 21-11: Electrical and communication preproduction capital costs.....	21-12
Table 21-12: Site infrastructure preproduction capital costs.....	21-13
Table 21-13: Process plant preproduction capital costs .....	21-14
Table 21-14: Community infrastructure and relocation preproduction capital costs.....	21-16

Table 21-15: Tailings and water treatment preproduction capital costs .....	21-17
Table 21-16: Firm price quotations list.....	21-20
Table 21-17: Project sustaining capital cost summary .....	21-21
Table 21-18: Sustaining capital costs by year summary .....	21-22
Table 21-19: Underground sustaining capital costs.....	21-23
Table 21-20: Mine surface facilities sustaining capital costs .....	21-24
Table 21-21: Processing sustaining capital costs .....	21-24
Table 21-22: Tailings and water management sustaining capital costs .....	21-24
Table 21-23: Site rehabilitation and closure.....	21-25
Table 21-24: Salvage value .....	21-25
Table 21-25: Project operating cost summary .....	21-26
Table 21-26: Operating cost estimate combined inputs .....	21-28
Table 21-27: General rate and unit cost assumptions .....	21-28
Table 21-28: Underground mining operating costs.....	21-29
Table 21-29: Unit costs for development .....	21-29
Table 21-30: Underground mining operating costs – dollars per year.....	21-30
Table 21-31: Process plant operating cost summary .....	21-31
Table 21-32: Annual reagent costs .....	21-33
Table 21-33: Annual process plant maintenance costs by area .....	21-34
Table 21-34: Media wear and consumption rates.....	21-35
Table 21-35: Tailings, water treatment and environment operating cost summary.....	21-38
Table 21-36: Average general and administrative costs.....	21-39
Table 21-37: Summary of personnel – all areas .....	21-40
Table 22-1: Financial model parameters .....	22-2
Table 22-2: Financial analysis summary (pre-tax and after-tax).....	22-6
Table 22-3: Horne 5 Project financial model summary.....	22-8
Table 22-4: Production cost summary .....	22-11
Table 22-5: NPV sensitivity results (after-tax) for metal price and exchange rate variations .....	22-12
Table 22-6: IRR sensitivity results (after-tax) for metal price and exchange rate variations .....	22-12
Table 22-7: NPV sensitivity results (after-tax) for operating and capital cost variations.....	22-12

---

Table 22-8: IRR sensitivity results (after-tax) for operating and capital cost variations.....	22-13
Table 22-9: NPV sensitivity results (after-tax) for discount rate.....	22-13
Table 24-1: Key Project activities.....	24-5
Table 25-1: Evolution of Horne 5 datasets and mineral resource estimates .....	25-5
Table 25-2: Horne 5 mineral resource (July 25, 2017) .....	25-8
Table 25-3: Statement of mineral reserves (August 26, 2017) .....	25-9
Table 25-4: Projected metallurgical recoveries and net payable values for Au, Ag, Cu and Zn .....	25-18
Table 25-5: Calculation of net payable metal content in products .....	25-24
Table 25-6: Project capital costs (preproduction and sustaining) .....	25-25
Table 25-7: Project operating costs .....	25-26
Table 25-8: Personnel summary – all areas .....	25-26
Table 25-9: Project risks (preliminary risk assessment) .....	25-29
Table 25-10: Project opportunities .....	25-42
Table 26-1: Proposed activities.....	26-3

## LIST OF FIGURES

Figure 1-1: Horne 5 Project location in Québec.....	1-5
Figure 1-2: Underground mine infrastructure.....	1-15
Figure 1-3: Simplified process plant flowsheet .....	1-20
Figure 1-4: General site layout – Horne 5 Mining Complex.....	1-21
Figure 1-5: Capital cost summary (preproduction) .....	1-32
Figure 1-6: Overall capital cost profile .....	1-33
Figure 1-7: Operating cost summary (by area).....	1-34
Figure 1-8: Annual Payable Gold Production (koz) .....	1-37
Figure 1-9: Net present value (5% discount rate, after-tax) sensitivity analysis .....	1-38
Figure 1-10: Internal rate of return (after-tax) sensitivity analysis.....	1-39
Figure 4-1: Location of the Horne 5 deposit in the province of Québec .....	4-3
Figure 4-2: Location map for the Falco Property .....	4-7
Figure 4-3: Location of the Horne 5 deposit within the Concession .....	4-8
Figure 5-1: Topography and accessibility of mining concession CM-156TP.....	5-2
Figure 5-2: Aerial view of the available infrastructure near the proposed Horne 5 Mining Complex.....	5-3
Figure 6-1: Excerpt from Price (1933) showing details of the 1932 ore reserve estimate for the Horne mine .....	6-4
Figure 7-1: Stratigraphic map of the Abitibi Greenstone Belt .....	7-3
Figure 7-2: Generalized geologic map of the Noranda mining camp, showing major structural elements and the distribution of extrusive and intrusive rocks.....	7-5
Figure 7-3: Geology of the Horne Block and surrounding areas .....	7-8
Figure 7-4: Volcanic reconstruction of the Horne sequence, with informal subdivisions, based on the geology of the 975 ft level.....	7-9
Figure 7-5: Simplified stratigraphic section through the Horne 5 deposit .....	7-10
Figure 7-6: Geology of the 200-ft level at the Horne mine showing the Upper H and G orebodies .....	7-14
Figure 7-7: Simplified vertical cross section through the Horne 5 mine (section 50 East, looking west) .....	7-16
Figure 7-8: Geology of level 21 of the Horne 5 deposit, based on unpublished maps of Noranda Mines Ltd. ....	7-17
Figure 7-9: Paleotopographic model for the relative locations on the flank of a rhyolitic edifice of the Upper H orebodies (proximal deep grabens) and the Horne 5 deposit (distal broad depressions) .....	7-19



Figure 7-10: Geology of level 27, Horne mine, based on unpublished maps of Noranda Mines Ltd. .... 7-20

Figure 7-11: Composite level plans showing shape and distribution of massive sulphides in the Horne 5 deposit and their relationship to the Lower H orebody ..... 7-21

Figure 7-12: Host rock – orebody sequences of the Horne 5 deposit, along horizontal drilling transects on levels 27, 49 and 65 ..... 7-23

Figure 7-13: Cu-Au-Zn profiles of the Horne 5 deposit, along horizontal drilling transects on levels 27 (a) and 41 (b) ..... 7-24

Figure 7-14: Longitudinal section through the Horne mine, looking north, showing Au-rich spines within the Horne 5 deposit ..... 7-25

Figure 7-15: Horne 5 mineralized envelopes ..... 7-27

Figure 7-16: Additional mineralized envelope ENV\_E ..... 7-28

Figure 7-17: Additional mineralized envelope ENV\_F ..... 7-29

Figure 7-18: Horne 5 mineralized envelopes and high-grade gold zones ..... 7-30

Figure 7-19: Horne 5 historically delineated high-grade Au-bearing trend (left), compared to the high-grade Au-bearing zones defined in the November 2016 MRE (right) ..... 7-31

Figure 7-20: Horne 5 mineralized envelopes and high-grade Cu zones ..... 7-32

Figure 7-21: Horne 5 mineralized envelopes and high-grade Zn zones ..... 7-32

Figure 7-22: Horne 5 mineralized envelopes and zones of high specific gravity ..... 7-33

Figure 7-23: Horne 5 lithostructural model constructed in 2015 (left); Noranda’s geological interpretation constituted the main support (right) to construct the 3D model ..... 7-34

Figure 7-24: Support for the 2015 Horne 5 lithostructural model in the form of a 2D geological interpretation realized on key plan views (left) ..... 7-34

Figure 7-25: 3D view of updated Horne 5 lithostructural model for volcanic lithologies ..... 7-36

Figure 7-26: 3D view of updated Horne 5 lithostructural model for synvolcanic diabases (metadiabases) ... ..... 7-37

Figure 7-27: 3D view of updated Horne 5 lithostructural model for late-tectonic (Proterozoic) diabases (left) and granite and syenite stocks (centre) ..... 7-38

Figure 7-28: 3D view of the updated Horne 5 lithostructural model for major faults ..... 7-40

Figure 7-29: 3D view of updated 2016 Horne 5 lithostructural model for secondary faults ..... 7-41

Figure 7-30: 3D view of updated Horne 5 lithostructural model for the massive sulphide envelope (left) and mineralizations (central and right) ..... 7-43

Figure 7-31: 3D view of updated Horne 5 lithostructural model for alterations ..... 7-45

Figure 7-32: 3D view of updated Horne 5 lithostructural model for veins ..... 7-47

Figure 8-1: Graphic representation of the lithological classifications.....	8-2
Figure 9-1: Relationship between silver and sulphur for the three sulphide facies .....	9-2
Figure 9-2: Examples of Noranda’s historical plans (with close-ups) .....	9-6
Figure 9-3: Example illustrating the conversion of historical gold values expressed as ounces per ton (oz/t) (red outline; left) to grams per tonne (g/t) (right) .....	9-7
Figure 9-4: Plan view looking down on level 49 illustrating the relationship between gold grades in channel samples and those of nearby DDH (left).....	9-8
Figure 9-5: 3D view looking NE showing 3,350 Noranda DDH for which geological information was added to the database .....	9-11
Figure 9-6: Illustration of PDF log used for the compilation of geological information – DDH HN_27-7390 - 1 page.....	9-13
Figure 9-7: Transformation of geological historical information on Noranda vertical cross section (left) into Excel spreadsheet data (centre) and incorporation into the drill hole database (right).....	9-15
Figure 9-8: 3D views of digitized lines used to form “Dyke M” domains.....	9-17
Figure 10-1: Location map of the confirmation drill holes realized in 2016 showing the projection of the main mineralized envelope (ENV_A) .....	10-2
Figure 10-2: Different views of confirmation drill holes that intersected the main mineralized envelope (ENV_A).....	10-3
Figure 10-3: Location map of the drill hole from the Horne 5 West Program realized in 2016 showing the projection of the main mineralized envelope (ENV_A).....	10-7
Figure 10-4: Different views of the drill holes from the Horne 5 West Program .....	10-8
Figure 10-5: Composite longitudinal view and close-up view of slight extension of ENV_A based on results from drill hole H5-16-17-A.....	10-9
Figure 11-1: Difference between accuracy and precision.....	11-6
Figure 11-2: Plot of gold pulp duplicates from ALS Chemex in 2015 (left) and Actlabs in 2016 (right)...	11-9
Figure 11-3: Plot of silver pulp duplicates from ALS Chemex in 2015 (left) and Actlabs in 2016 (right).....	11-10
Figure 11-4: Plot of copper pulp duplicates (ppm) from ALS Chemex in 2015 (left) and Actlabs in 2016 (right) .....	11-11
Figure 11-5: Plot of zinc pulp duplicates (ppm) from ALS Chemex in 2015 (left) and Actlabs in 2016 (right) .....	11-12
Figure 11-6: Plot of gold coarse duplicates from ALS Chemex in 2015 (left) and Actlabs in 2016 (right).....	11-15
Figure 11-7: Plot of silver coarse duplicates from ALS Chemex in 2015 (left) and Actlabs in 2016 (right) .....	11-16

Figure 11-8: Plot of copper coarse duplicates from ALS Chemex in 2015 (left) and Actlabs in 2016 (right) ..... 11-17

Figure 11-9: Plot of zinc coarse duplicates from ALS Chemex in 2015 (left) and Actlabs in 2016 (right) ..... 11-18

Figure 12-1: Photographs showing general presentation of quarter-split core after resampling..... 12-5

Figure 12-2: Linear graphs comparing original and quarter-split assays for gold (top) and copper (bottom) ..... 12-6

Figure 12-3: Linear graphs comparing original and quarter-split assays for zinc (top) and silver (bottom) ..... 12-7

Figure 12-4: Graphs comparing Noranda’s calculated SG values for original core samples to InnovExplo’s calculated (top) and measured (bottom) SG values for quarter-split samples ..... 12-8

Figure 12-5: Composite longitudinal view looking north illustrating the proportion and distribution of historical underground drill holes with pre-1948 (red) and post-1948 assays (green) ..... 12-12

Figure 12-6: Contact plot for the main mineralized envelope of the Horne 5 deposit comparing pre- and post-1948 assays values for gold (top left), zinc (top right) and copper (bottom) ..... 12-13

Figure 12-7: Probability plots of low-grade gold values in g/t reported historically as \$/t (top) and oz/t (bottom) ..... 12-14

Figure 12-8: 3D view looking NE comparing the historical DDH (“Noranda’s drill holes”) used in the April 2014 and March 2016 MRE (left), and the holes added to the October 2017 MRE (right) ..... 12-16

Figure 12-9: 3D plan view looking down on level 49 illustrating the gold grade correlation between channel samples and nearby DDH..... 12-18

Figure 12-10: 3D plan view looking down on level 49 illustrating the Au grade correlation between channel samples and nearby DDH (left) ..... 12-19

Figure 12-11: Comparison between channel sample composites and drill hole sample composites for ENV\_A (Rock code 210) ..... 12-20

Figure 12-12: Comparison between channel sample composites and drill hole sample composites for HG\_A (Rock code 110) ..... 12-21

Figure 12-13: Cylinder with a 15-m radius around confirmation drill holes cutting Horne 5 mineralization ..... 12-23

Figure 12-14: Illustration of a cylinder with a 15-m radius (transparent red shape) around confirmation drill hole (H5-15-08-W) cutting high-grade gold subzone HG\_B ..... 12-23

Figure 12-15: Illustration of good correlation between a pilot hole (H5-15-08) and its wedge (H5-15-08-W) for raw gold (left) and silver (right) assays ..... 12-27

Figure 12-16: Illustration of good correlation between a pilot hole (H5-15-08) and its wedge (H5-15-08-W) for raw copper (left) and zinc (right) assays ..... 12-27

Figure 12-17: Average silver content per SG class .....	12-28
Figure 12-18: Half-core witness samples from mineralized zones .....	12-29
Figure 13-1: Section (looking north) of PEA drill hole pierce points within overall resource envelope....	13-3
Figure 13-2: Sections showing main resource envelope .....	13-11
Figure 13-3: Sections showing high-grade Au zones within main resource envelope .....	13-12
Figure 13-4: Sections showing high-grade Cu zones within main resource envelope .....	13-13
Figure 13-5: Sections showing high-grade Zn zones within main resource envelope .....	13-14
Figure 13-6: Sections showing high-grade sulphide zones within main resource envelope .....	13-15
Figure 13-7: Mineralogical distribution of gold occurrences in flotation composites M1 to M4 .....	13-20
Figure 13-8: Mineralogical distribution of gold occurrences in flotation composites M5 to M9 .....	13-21
Figure 13-9: Gold liberation study for composites M1 to M4 .....	13-22
Figure 13-10: Comparison of grindability samples sulphur assays .....	13-24
Figure 13-11: Relation between bond rod mill work index and sulphur grade.....	13-26
Figure 13-12: Relation between bond ball mill work index and sulphur grade (150M closing sieve) ....	13-26
Figure 13-13: Relation between rock specific gravity and sulphur grade .....	13-27
Figure 13-14: Relation between abrasion index and sulphur grade .....	13-27
Figure 13-15: Relation between SAGDesign SAG work index and sulphur grade.....	13-28
Figure 13-16: Relation between SAGDesign ball mill work index and sulphur grade .....	13-28
Figure 13-17: SAGDesign SAG grindability index distribution for PEA study and FS composites.....	13-29
Figure 13-18: Starkey ball mill pinion energy distribution for PEA and FS composites.....	13-29
Figure 13-19: Selected percentiles of sulphur distribution from mined stope tonnage per period .....	13-31
Figure 13-20: Cumulative sulphur distribution from mined stope tonnage over LOM .....	13-32
Figure 13-21: Cu recovery to rougher concentrate vs Cu feed grade .....	13-42
Figure 13-22: Weight recovery to Cu rougher concentrate vs Cu feed grade .....	13-43
Figure 13-23: Au recovery to Cu rougher concentrate vs mass pull to Cu rougher concentrate .....	13-44
Figure 13-24: Ag recovery to Cu rougher concentrate vs mass pull to Cu rougher concentrate .....	13-45
Figure 13-25: Overall and rougher Cu recoveries vs Cu feed grade.....	13-46
Figure 13-26: Cu cleaning circuit Au recovery vs mass pull to Cu concentrate .....	13-47
Figure 13-27: Mass pull to Cu concentrate vs Cu feed grade .....	13-48
Figure 13-28: Mass pull to Cu concentrate vs Cu feed grade (filtered data).....	13-49

Figure 13-29: Cu cleaning circuit and global Au recovery vs mass pull to Cu concentrate .....	13-50
Figure 13-30: Cu cleaning circuit Au recovery vs mass pull to Cu concentrate .....	13-51
Figure 13-31: Cu cleaning circuit and global Ag recovery vs mass pull to Cu concentrate .....	13-52
Figure 13-32: Zn recovery to Cu concentrate vs Zn head grade .....	13-53
Figure 13-33: Zn circuit Zn recovery vs Zn circuit head grade .....	13-54
Figure 13-34: Au recovery to Zn circuit vs Au/Zn head grade ratio to Zn circuit .....	13-55
Figure 13-35: Ag recovery to Zn circuit vs Ag/Zn head grade ratio to Zn circuit .....	13-56
Figure 13-36: Global Ag recovery to Zn conc. vs Ag/Zn head grade ratio to Zn circuit.....	13-57
Figure 13-37: Pyrite rougher weight recovery to sulphide content .....	13-58
Figure 13-38: Au partial recovery to pyrite rougher concentrate versus S head grade .....	13-59
Figure 13-39: Ag partial recovery to pyrite rougher concentrate versus S head grade .....	13-60
Figure 13-40: Au leaching kinetics for pyrite concentrate (Tests CN5-10) .....	13-68
Figure 13-41: Au leaching kinetics for pyrite concentrate – FS Phase 1 (Tests CN7-18, CN42-49).....	13-71
Figure 13-42: Ag leaching kinetics for pyrite concentrate – FS Phase 1 (Tests CN7-18, CN42-49).....	13-71
Figure 13-43: Effect of pyrite concentrate $P_{80}$ on Au leaching – FS Phase 1 .....	13-72
Figure 13-44: Effect of pyrite concentrate $P_{80}$ on Ag leaching – FS Phase 1 .....	13-73
Figure 13-45: Au in pyrite conc. cyanidation tails vs Au in feed to circuit .....	13-74
Figure 13-46: Ag in pyrite conc. cyanidation tails vs Ag in feed to circuit .....	13-75
Figure 13-47: Au in pyrite tails leaching tails vs Au in feed to circuit .....	13-78
Figure 13-48: Ag in pyrite tails leaching tails vs Ag in feed to circuit .....	13-79
Figure 13-49: Isa mill signature curves with pyrite concentrate .....	13-80
Figure 13-50: Comparison of HIG mill vs Isa mill signature curves .....	13-81
Figure 13-51: Yield stress vs slurry density for copper concentrate .....	13-92
Figure 13-52: Yield stress vs slurry density for zinc concentrate .....	13-93
Figure 13-53: Yield stress vs slurry density for pyrite concentrate .....	13-94
Figure 13-54: Yield stress vs slurry density for reground pyrite concentrate .....	13-95
Figure 13-55: Yield stress vs slurry density for pyrite tailings .....	13-96
Figure 13-56: 50/50 PFT/PCT pressure filter cake (left) and filtrate (right) .....	13-98
Figure 13-57: 50/50 PFT/PCT vacuum filtration cakes – 53.5% w/w slurry feed (left) and 60% w/w (right) .....	13-99
Figure 13-58: Filtered cake of 100% PFT and 50/50 PCT/PFT .....	13-100

Figure 14-1: 3D view looking NE showing the Horne 5 deposit and the bounding box for the block model ..... 14-3

Figure 14-2: 3D view looking NE comparing the DDH used in the November 2016 MRE (left) and the holes added to the October 2017 MRE (right)..... 14-4

Figure 14-3: 3D view looking NE showing DDH that were used for the historical metallurgical testing program ..... 14-5

Figure 14-4: Close-up view of one of Noranda’s historical plans showing the channel samples and assay results from the historical underground sampling program ..... 14-6

Figure 14-5: 3D view looking NE showing the channel samples with assay results from the historical channel sampling program ..... 14-7

Figure 14-6: Low-grade gold zones (both on top) and high grade gold zones (both at bottom) in the Horne 5 deposit ..... 14-10

Figure 14-7: Summary statistical plots for gold capping in HG\_C (block code 130) ..... 14-15

Figure 14-8: Summary statistical plots for capping gold in ENV\_A (block code 210)..... 14-16

Figure 14-9: Example of histogram illustrating the two main sample length classes identified within ENV\_A (block code 210) ..... 14-17

Figure 14-10: Example of 3D variograms along the major axes..... 14-22

Figure 14-11: Probability plot of gold for high-grade zone HG\_C..... 14-32

Figure 14-12: Probability plot of gold for mineralized envelope ENV\_A..... 14-33

Figure 14-13: Gold swath plot (100 m vertical) of ENV\_A and HG\_A to HG\_E ..... 14-34

Figure 14-14: Silver swath plot (100 m vertical) of HG\_Ag (block code 250)..... 14-35

Figure 14-15: Copper swath plot (100 m vertical) of HG\_Cu and ENV\_A..... 14-36

Figure 14-16: Zinc swath plot (100 m vertical) of HG\_Zn and ENV\_A ..... 14-37

Figure 14-17: 3D plan view looking down on level 43 illustrating how mineralized zones are supported by channel samples (top left) and DDH information (top right) with gold assays..... 14-41

Figure 14-18: Composite longitudinal views, looking north, illustrating the distribution of the blocks classified as Inferred (left), Indicated (centre) and Measured (right) in the Horne 5 deposit ..... 14-42

Figure 14-19: Waterfall chart of the changes since the November 2016 MRE ..... 14-48

Figure 14-20: Longitudinal view comparing blocks for the November 2016 MRE and the October 2017 MRE ..... 14-49

Figure 16-1: Location of the primary major faults – view looking west ..... 16-11

Figure 16-2: Plan view of secondary major faults intersections on typical Phase 1 level ..... 16-11

Figure 16-3: Mining zones – longitudinal section..... 16-14

Figure 16-4: Hydraulic conductivity profile – borehole H5-15-06.....	16-29
Figure 16-5: Connections between historical mines .....	16-34
Figure 16-6: Quemont mine 3D model.....	16-36
Figure 16-7: Chadbourne mine 3D model.....	16-38
Figure 16-8: Joliet mine 3D model .....	16-40
Figure 16-9: Donalda mine 3D model .....	16-42
Figure 16-10: Horne mine 3D model.....	16-44
Figure 16-11: Temporary dewatering network – main steps (1 to 3).....	16-47
Figure 16-12: Surface pumping station general arrangement .....	16-48
Figure 16-13: Typical booster pump installed on a Galloway.....	16-49
Figure 16-14: Drainage system installation.....	16-50
Figure 16-15: Estimated volume of water stored in underground workings .....	16-53
Figure 16-16: Final conditions of dewatering – step 1 .....	16-57
Figure 16-17: Final conditions of dewatering – step 2 .....	16-58
Figure 16-18: Final conditions of dewatering – step 3 .....	16-60
Figure 16-19: Dewatering schedule .....	16-62
Figure 16-20: Q275, Q715 and Q1180, Typical permanent electrical station .....	16-63
Figure 16-21: Typical permanent substation.....	16-65
Figure 16-22: Typical production substation .....	16-67
Figure 16-23: Fibre and leaky feeder networks .....	16-69
Figure 16-24: Schematic fuel distribution network.....	16-71
Figure 16-25: Permanent mine pumping network general layout.....	16-74
Figure 16-26: Permanent clear water pumping station layout .....	16-76
Figure 16-27: Typical underground multistage pump dewatering station.....	16-76
Figure 16-28: Conceptual clarification station process diagram .....	16-78
Figure 16-29: Dewatering and rehabilitation ventilation – step 1.....	16-79
Figure 16-30: Dewatering and rehabilitation ventilation – step 2.....	16-81
Figure 16-31: Dewatering and rehabilitation ventilation – step 3.....	16-82
Figure 16-32: Preproduction ventilation network – level L322.....	16-84
Figure 16-33: Preproduction ventilation network – level L790.....	16-86



Figure 16-34: Preproduction ventilation network – level L1190.....	16-87
Figure 16-35: Complete preproduction/development ventilation network .....	16-89
Figure 16-36: Permanent ventilation network with escape ways.....	16-96
Figure 16-37: Heat sources for the Horne 5 underground mine .....	16-100
Figure 16-38: Quemont No. 2 existing shaft .....	16-102
Figure 16-39: Quemont No. 2 rehabilitated shaft.....	16-103
Figure 16-40: Horne 5 underground mine and Quemont No. 2 shaft levels.....	16-106
Figure 16-41: Typical temporary loading station.....	16-107
Figure 16-42: Loading station at levels Q1180 and Q1851 .....	16-108
Figure 16-43: Main infrastructure location in the mine.....	16-109
Figure 16-44: Typical production level – general arrangement with storage and level in ore .....	16-110
Figure 16-45: Typical production level – general arrangement with refuge and level in waste .....	16-111
Figure 16-46: Garage and service infrastructure general arrangement – level L1190.....	16-112
Figure 16-47: Ore pass configuration .....	16-115
Figure 16-48: Elevation view of the material handling network .....	16-118
Figure 16-49: Ore handling ore passes diagram – Phase 1 .....	16-120
Figure 16-50: Ore crushing and handling diagram – Phase 1 .....	16-121
Figure 16-51: Material handling infrastructure – Plan view Phase 1 .....	16-122
Figure 16-52: Underground infrastructure diagram – Phase 2 ore handling .....	16-124
Figure 16-53: Typical drilling-blasting-backfilling sequence of the transverse long hole mining method (2) .....	16-130
Figure 16-54: Particle size curve comparison between 165 mm and 203 mm blast hole diameters (BBA, 2017) .....	16-131
Figure 16-55: Linear extrapolation for weight of explosive vs depth from surface .....	16-134
Figure 16-56: Plan view of a typical drilling pattern .....	16-135
Figure 16-57: Typical drilling and blasting pattern for levels L710 to L830 .....	16-136
Figure 16-58: Typical drilling and blasting pattern for levels L870 to L1110 .....	16-137
Figure 16-59: Typical drilling and blasting pattern for levels L1150 to L1310 .....	16-138
Figure 16-60: Typical drilling and blasting pattern for levels L710 and L750, upper stopes .....	16-141
Figure 16-61: Typical drilling and blasting pattern for levels L1340 to L1880 .....	16-142
Figure 16-62: Typical drilling and blasting pattern for levels L1910 to L2060 .....	16-143



Figure 16-63: Production sequence for the Horne 5 Project .....	16-146
Figure 16-64: Pyramidal mining sequence .....	16-148
Figure 16-65: Illustration of mining sequence constraints (section view) .....	16-149
Figure 16-66: Isometric view of mining sequence .....	16-149
Figure 16-67: Particle size distribution .....	16-154
Figure 16-68: Cemented paste backfill strength results .....	16-156
Figure 16-69: Cemented paste backfill distribution for Horne 5 Mining Complex.....	16-158
Figure 16-70: Proposed surface slurry pipeline on Horne property .....	16-173
Figure 16-71: Typical plug design for Quemont and Horne mines .....	16-180
Figure 17-1: Schematic process diagram – concentrator .....	17-2
Figure 17-2: Schematic process diagram – gold recovery circuits .....	17-3
Figure 17-3: Process plant layout from 3D model .....	17-4
Figure 17-4: Yearly sulphur content (percentile distribution) .....	17-6
Figure 17-5: 3D model arrangement of the SAG mill and ball mill circuit .....	17-10
Figure 17-6: Configuration of the flotation circuit – close-up on copper and zinc circuits.....	17-15
Figure 17-7: Configuration of the flotation circuit – close-up on the pyrite circuit .....	17-16
Figure 17-8: Concentrate dewatering area – view from west .....	17-22
Figure 17-9: Concentrate dewatering area – view from east.....	17-22
Figure 17-10: Configuration of the pyrite concentrate regrinding circuit.....	17-26
Figure 17-11: Configuration of the leach tanks .....	17-28
Figure 17-12: Configuration of the CIP and gold recovery circuits .....	17-31
Figure 17-13: Isometric view of the paste backfill plant .....	17-37
Figure 17-14: Batching reagents area .....	17-40
Figure 17-15: Proces plant control system generic topology.....	17-44
Figure 17-16: Process plant water balance .....	17-50
Figure 18-1: Project site overview including pipeline between the future Horne 5 Mining Complex and the TMF .....	18-2
Figure 18-2: General site layout drawing .....	18-4
Figure 18-3: Typical cross-section showing stratigraphy .....	18-6
Figure 18-4: Mining complex parking lot and site access control .....	18-8

Figure 18-5: Proposed overhead line from the Hydro-Québec Rouyn-Noranda substation to the Mining Complex.....	18-9
Figure 18-6: 120 kV Outdoor substation isometric view .....	18-10
Figure 18-7: Headframe and hoist room buildings.....	18-12
Figure 18-8: Hoisting system .....	18-14
Figure 18-9: Isometric view of the processing plant .....	18-18
Figure 18-10: Warehouse .....	18-18
Figure 18-11: Mine office/dry building.....	18-19
Figure 18-12: Administration building .....	18-20
Figure 18-13: Underground utility piping.....	18-23
Figure 18-14: TMF infrastructure at the end of Stage 4 (2033) .....	18-27
Figure 18-15: Ditches and pumping basins .....	18-31
Figure 18-16: Simplified water treatment plans – preproduction and production .....	18-35
Figure 18-17: Simplified water treatment plans for progressive closure.....	18-39
Figure 18-18: Water treatment plant isometric diagram .....	18-46
Figure 18-19: Simplified HDS process flow diagram .....	18-47
Figure 18-20: Fresh water pipeline .....	18-52
Figure 20-1: Environmental components and study areas – Horne 5 Mining Complex .....	20-17
Figure 20-2: Environmental Components and Study Areas – TMF Site.....	20-18
Figure 20-3: Assessment of alternatives for surface TMF .....	20-30
Figure 20-4: Simulated Piezometry of the Upper Bedrock – Closure Conditions.....	20-32
Figure 20-5: Plan View of Norbec Mine Site .....	20-35
Figure 20-6: General geotechnical conditions for Norbec mine site.....	20-38
Figure 20-7: Surficial Geology of the Norbec Mine Site.....	20-39
Figure 20-8a: PCT and PFT particle size distribution curves .....	20-41
Figure 20-8b: PFT standard Proctor testing results.....	20-41
Figure 20-9: Plan view of the Horne5 TMF at surface .....	20-44
Figure 20-10: Surface TMF development sequence – Stage 1 .....	20-47
Figure 20-11: Surface TMF development sequence – Stage 2.....	20-48
Figure 20-12: Surface TMF development sequence – Stage 3.....	20-49
Figure 20-13: Surface TMF development sequence – Stage 4.....	20-50

---

Figure 20-14: Surface TMF development sequence – Stage 5 .....	20-51
Figure 20-15: PFT-1 cross-section .....	20-57
Figure 20-16: Median Dike cross-section .....	20-58
Figure 20-17: Internal Dike cross-section .....	20-59
Figure 20-18: Water management strategy diagram – preproduction period.....	20-65
Figure 20-19: Water management strategy diagram – production period (with and without surface TMF) .....	20-66
Figure 20-20: Water management at the Horne 5 Mining Complex – ditches and pumping basins .....	20-71
Figure 20-21: TMF surface water infrastructure (End of Stage 4) .....	20-72
Figure 20-22: Social Components and Study Areas – Horne 5 Mining Complex.....	20-94
Figure 20-23: Social Components and Study Areas – TMF Site .....	20-95
Figure 21-1: Distribution of preproduction capital costs.....	21-8
Figure 21-2 Project sustaining capital cost summary .....	21-21
Figure 21-3: Project operating cost summary .....	21-26
Figure 21-4: Process operating cost breakdown .....	21-32
Figure 22-1: Annual Payable Gold Production (koz) .....	22-4
Figure 22-2: Overall Horne 5 Project capital cost profile .....	22-5
Figure 22-3: Life of mine cash flow projection (cumulative, pre-tax and after-tax) .....	22-10
Figure 22-4: Sensitivity of the net present value (after-tax) to financial variables .....	22-14
Figure 22-5: Sensitivity of the internal rate of return (after-tax) to financial variables .....	22-14
Figure 23-1: Adjacent properties to the Horne 5 deposit .....	23-3
Figure 24-1: Project construction management team organizational chart .....	24-4
Figure 24-2: Construction phase on-site workforce requirement.....	24-7

TABLE OF ABBREVIATIONS

Abbreviation	Description
$\sigma_{ci}$	Uniaxial compressive strength
3D	Three dimensional
A	Ampere
a	Annum (year)
AA	Atomic absorption
AACE	American Association of Cost Engineers
Ag	Silver
AGDC	Alex G. Doll Consulting
Ai	Abrasion index
AISC	All-in sustaining cost
AMQ	Association Minière du Québec
AND	Andesite
ANFO	Ammonium nitrate fuel oil
AQI	Air Quality Index
ARD	Acid rock drainage
As	Arsenic
ASTM	American Section of the International Association for Testing Materials
Au	Gold
AuEq	Gold equivalent
Au-rich VMS	Gold-rich volcanogenic massive sulphide
B	Billion
BAPE	Bureau d'audience publique sur l'environnement du Québec
BBA	BBA Inc.
BBE	BBE Consulting Canada
Bi	Bismuth
BTS	Brazilian indirect tensile strength
Btu	British thermal units
BV	Bed volume (for volume equivalent to that occupied by activated carbon)
BWi	Bond work index
C	Carbon
Ca(OH) <sub>2</sub>	Calcium hydroxide
ca.	Approximately
CAD or \$	Canadian dollar
CaO	Lime
CAPEX	Capital expenditure
CAR	Clean air regulation

**TABLE OF ABBREVIATIONS**

<b>Abbreviation</b>	<b>Description</b>
CCTV	Closed circuit television
Cd	Cadmium
CDA	Canadian Dam Association
CDPNQ	Centre de données sur le patrimoine naturel du Québec
CEAA	Canadian Environmental Assessment Act
CEAEQ	Centre d'expertise en analyse environnementale du Québec
CEO	Chief executive officer
CIL	Carbon in leach
CIM	Canadian Institute of Mining, Metallurgy and Petroleum
CIP	Carbon in pulp
Cl	Chloride
Cl conc.	Cleaner concentrate
CMT	Construction management team
CN	Cyanide
CND	Cyanide destruction
CNL	Cyanidation
CN <sub>T</sub>	Total cyanide
CN <sub>WAD</sub>	Weak acid dissociable cyanide
Co	Cobalt
CO <sub>2</sub>	Carbone dioxide
CoA	Certificate of authorization
conc.	Concentrate
Concession	Mining concession CM-156PTB
Concession 243	Mining concession CM-243
CPC	Capital Pool Company
CPC(EO)	Critère de qualité pour la prévention de la contamination de l'eau et des organismes aquatiques
Cr	Chromium
CRM	Certified reference material
CSSS	Centre intégré de santé et des services sociaux
Cu	Copper
Cu <sup>2+</sup>	Copper (II) ion
CuSO <sub>4</sub>	Copper sulphate
CVAC	Critère de qualité pour la protection de la vie aquatique - effet chronique
DB	Dry-bulb
DC	Direct current

**TABLE OF ABBREVIATIONS**

<b>Abbreviation</b>	<b>Description</b>
DDH	Diamond drill hole
DIA	Diabase
DIO	Diorite
Directive 019	MDDELCC - Directive 019 sur l'industrie minière (Provincial guidelines for the mining industry)
DO	Dissolved oxygen
DOCSIS	Data Over Cable Service Interface Specification
Druk	Druk Capitals Partners Inc.
DSO	Deswik shape optimizer
EA	Environmental assessment
EBIT	Earnings before interest and taxes
EC	Environment Canada
EGL	Effective grinding length
EIA	Environmental Impact Assessment
EPCM	Engineering, Procurement, Construction Management
EQA	Environmental Quality Act
et al.	et alla (and others)
EW	Electrowinning
F	Fluorine
F <sub>100</sub>	100% passing - Feed size
F <sub>80</sub>	80% passing - Feed size
Falco	Falco Resources Ltd.
Fe	Iron
Fe <sup>2+</sup>	Ferrous iron
Fe <sup>3+</sup>	Ferric iron
Fe <sub>3</sub> O <sub>4</sub>	Magnetite
Fe <sub>T</sub>	Total iron
FOB	Freight on board
FoS	Factors of safety
FS	Feasibility study
FWR	Fresh water reservoir
<i>g</i>	Gravitational acceleration
G&A	General and Administration
Ga	Billion years
GCMP	Ground control management plan
GEMS	Geovia GEMS software

**TABLE OF ABBREVIATIONS**

<b>Abbreviation</b>	<b>Description</b>
GHG	Greenhouse Gas
GIS	Gas insulated switchgear
GPR	Ground penetrating radar
GT	Geothermal gradient
GW	Ground water
GWh	Gigawatt hour
H <sub>2</sub> O <sub>2</sub>	Hydrogen peroxide
H <sub>2</sub> S	Hydrogen sulfide
H <sub>2</sub> SO <sub>4</sub>	Sulphuric acid
HCF	Hunter Creek Fault
HCl	Hydrochloric acid
HDD	Horizontal directional drilling
HDS	High density sludge
HG	High grade zone
Hg	Mercury
HIG mill	High intensity grinding mill
HMI	human-machine interface
HVAC	Heating, ventilation, and air conditioning
I/O	Input/output
ICMM	International Council on Mining and Metals
ICP	Inductively coupled plasma
ICP-OES	Inductively coupled plasma atomic emission spectroscopy (also referred to as inductively coupled plasma optical emission spectrometry)
ID <sup>2</sup>	Inverse distance square
IEC	International Electrotechnical Commission
In	Indium
InSAR	Interferometric synthetic aperture radar
IOS	International Organization for Standardization
IPO	Initial public offering
IRR	Internal rate of return
Isa mill	Energy-efficient mineral industry grinding mill
IT	Information technology
JV	Joint venture
K <sub>2</sub> O	Potassium oxide
LBMA	London Bullion Market Association
LCT	Locked-cycle (flotation) test

**TABLE OF ABBREVIATIONS**

<b>Abbreviation</b>	<b>Description</b>
LDS	Low density sludge
LHD	Load haul dump
Ln	Log-normal
LOM	Life of mine
LTP	Lime water treatment plant
LUDP	Land Use and Development Plan
M	Million
m.a.s.l.	Metres above sea level
Ma	Mega annum
MCC	Motor control centre
MDDELCC	Ministère du Développement durable, de l'Environnement et de la Lutte contre les changements climatiques (Ministry of Sustainable Development, Environment, and Action against Climate Change) - formerly known as Ministère du Développement durable, de l'Environnement, de la Faune et des Parcs (MDDEFP),
MDDEP	Ministère du Développement durable, de l'Environnement et des Parcs du Québec
MEF	Ministère de l'Environnement et de la Faune du Québec
MENV	Ministère de l'Environnement du Québec
MERN	Ministère de l'Énergie et Ressources naturelles (Ministry of Energy and Natural Resources)
MFFP	Ministère des Forêts, de la Faune et des Parcs
MgO	Magnesium oxide
MIBC	Methyl isobutyl carbinol
MMER	Metal Mining Effluent Regulations
Mn	Manganese
Mo	Molybdenum
Mpa	Mega pascals
MPBX	Multi-point borehole extensometer
MRE	Mineral Resource Estimate
MS	Massive sulphide
MTOs	Material take-offs
MVA	Mega volt ampere
MW	Megawatt
Na <sub>2</sub> S <sub>2</sub> O <sub>5</sub>	Sodium metabisulfite
NaCN	Sodium cyanide
NaOH	Sodium hydroxide
NBCC	National Building Code of Canada
Ni	Nickel



**TABLE OF ABBREVIATIONS**

<b>Abbreviation</b>	<b>Description</b>
No.	Number
NOWL	Normal operating water levels
NPI	Net profits interest
NPV	Net present value
NS	North-south
NSR	Net smelter return
NTS	National topographic system
NVC	Noranda Volcanic Complex
O <sub>2</sub>	Oxygen
OPEX	Operational expenditure
OREAS	Name of the CRM (certified reference material)
OSA	On-stream analyzer
OT	Operation technology
OTMF	Old tailings management facilities
OUR	Oxygen uptake rate
Pa	Pascal
P <sub>100</sub>	100% passing - Product size
P <sub>80</sub>	80% passing - Product size
PAG	Potentially acid generating
PAX	Potassium amyl xanthate
Pb	Lead
PCS	Process control system
PCT	Pyrite concentrate tailings
PEA	Preliminary economic assessment
PFS	Prefeasibility study
PFT	Pyrite flotation tailings
PGA	Peak ground acceleration
pH	Potential of hydrogen
PhD	Doctor of philosophy
PLC	Programmable logic controller
PMF	Probable maximum flood
PMP	Probable maximum precipitation
PPV	Peak particle velocities
PSD	Particle size distribution
PTS	Total particle concentration
PVS	Peak vector sum

**TABLE OF ABBREVIATIONS**

<b>Abbreviation</b>	<b>Description</b>
Py	Pyrite
QA/QC	Quality Assurance/Quality Control
QMX	QMX Gold Corporation
QP	Qualified person
R <sup>2</sup>	Coefficient of determination
RCM	Royal Canadian Mint
RHY	Rhyolite
RMR	Rock mass rating
Ro conc.	Rougher concentrate
Ro tail	Rougher tailings
ROM	Run of mine
RQD	Rock quality designation
RWi	Rod work index
S	Sulphur
S.U.	Standard Unit
SAG	Semi-autogenous grinding
SAG <sub>std</sub>	Semi-autogenous grinding standard
SAS	Safety access system
Sb	Antimony
SDBWi	Ball mill pinion energy
SDW <sub>sag</sub>	SAG work index
Se	Selenium
SEDAR	System for electronic document analysis and retrieval
SG	Specific gravity
SGE	Specific grinding energy
SIGEOM	Système d'information géominière du Québec
SIH	Hydrogeological Information System
SiO <sub>2</sub>	Silicon dioxide / silica
SIPX	Sodium isopropyl xanthate
SMBS	Sodium metabisulfite
SMC	SAG mill comminution
SMS	Semi-massive sulphide
Sn	Tin
SO <sub>4</sub>	Sulphate
S <sub>T</sub>	Total sulphur
Starkey	Starkey & Associates Inc.

**TABLE OF ABBREVIATIONS**

<b>Abbreviation</b>	<b>Description</b>
Std	Standard S.U.
TARP	Trigger action response plan
TC/RC	Treatment charge/refining charge
TCS	Triaxial compressive strength
Te	Tellurium
Third Party	Shall designate Glencore Canada Corporation
TMF	Tailings management facility
TSF	Tailings storage facilities
TSS	Total solids in suspension
UCS	Uniaxial compressive strength
UDS	Underground distribution system
UDSUF	Underflowground distribution system
URSTM	Unité de recherche et de service en technologie minérale
USBM	United States Bureau of Mines
USD or US\$	United States dollar
UA	Unit capacity
UF	Underflow
UTM	Universal transverse mercator
VCF	Vauze creek fault
VFD	Variable frequency drives
VMS	Volcanogenic massive sulphide
VRT	Virgin rock temperature
vs	Versus
W.G.	Water guage
w/w	Weight per weight
WAD	Weak acid dissociable
WAD	Weak acid dissociable
WB	Wet-bulb
WBGT	Wet-bulb global temperature
WBS	Work breakdown structure
W <sub>BWI</sub>	SAG discharge bond ball mill work index
Wexplosive	Maximum charge weight per day (kg)
WQ	Water quality
W <sub>STD</sub>	SAG mill pinion energy
WTP	Water treatment plant
Zn	Zinc

TABLE OF ABBREVIATIONS – UNITS OF MEASURE	
Unit	Description
<b>Imperial</b>	
ac	acre
deg. or °	angular degree
B	Billion
Btu	British thermal units
ft <sup>3</sup>	cubic feet
ft <sup>3</sup> /h	cubic feet per hour
cfm	cubic feet per minute
cfs	cubic feet per second
yd <sup>3</sup>	cubic yard
d	day (24 hours)
°F	Degrees Fahrenheit
Ø	diameter
\$/st	Dollars per short ton
ft	feet (12 inches)
ft/d	feet per day
ft/s	feet per second
ft/s <sup>2</sup>	feet per second squared
gal	gallon
gpm	gallons (US) per minute
gal/h	gallons per hour
Hz	Hertz
hp	horsepower
h	hour (60 minutes)
in or “	inch
in Hg	inches of mercury
in WC	inches Water Column
kWh/t	kilowatt hour per ton
k	Kips / kilo (1,000 pounds)
k/ft <sup>2</sup>	kips per square foot
MW	Megawatt
µm	micron
mi	miles
mph	miles per hour
M	Million
MBtu	Million British thermal units

TABLE OF ABBREVIATIONS – UNITS OF MEASURE	
Unit	Description
<b>Imperial</b>	
Mgal/d	Million gallons per day
Mst	Million short ton
min	minute (60 seconds)
mil	one thousandth of an inch
ppm	parts per million
%	Percent
% solids	Percent solids by weight
lb	pound
lb/ft <sup>3</sup>	pounds per cubic foot
lb/gal	pounds per gallon
lb/h	pounds per hour
lb/min	pounds per minute
lb/lb	pounds per pound
psf	pounds per square foot
psi	pounds per square inch
psia	pounds per square inch - absolute
psig	pounds per square inch - gauge
lb/t	pounds per ton
rpm	revolutions per minute
s	second
st	short ton (2,000 lbs)
stpa	short tons per annum
stpd	short tons per day
stph	short tons per hour
stpy	short tons per year
SG	specific gravity
ft <sup>2</sup>	square feet
ft <sup>2</sup> /d	square feet per day
in <sup>2</sup>	square inch
scfm	standard cubic feet per minute
K	Thousand (000)
oz	Troy ounce
oz/t	Troy ounces per ton
oz/y	Troy ounces per year
mesh	US Mesh

<b>TABLE OF ABBREVIATIONS – UNITS OF MEASURE</b>	
<b>Unit</b>	<b>Description</b>
<b>Imperial</b>	
V	Volt
W	Watt
Wk	Week
wt%	weight percent
yd	yard (36 inches)
y	year (365 days)

TABLE OF ABBREVIATIONS – UNITS OF MEASURE	
Unit	Description
<b>Metric</b>	
deg. or °	angular degree
m <sup>3</sup>	cubic metre
m <sup>3</sup>	cubic metre
m <sup>3</sup> /h	cubic metres per hour
m <sup>3</sup> /m	cubic metres per minute
m <sup>3</sup> /min	cubic metres per minute
m <sup>3</sup> /s	cubic metres per second
d	day (24 hours)
°C	Degrees Celsius
∅	diameter
\$/t	Dollars per metric tonne
G	Giga
g	gram
g-Cal	gram - calories
g/t	grams per (metric) tonne
g/g	grams per gram
g/L	grams per Litre
g/y	grams per year
ha	Hectare
Hz	Hertz
h	hour (60 minutes)
kg	kilogram
kg	kilogram
kg/m <sup>2</sup>	kilogram per square metre
kg/m <sup>3</sup>	kilograms per cubic metre
kg/h	kilograms per hour
kg/min	kilograms per minute
kg/m <sup>2</sup>	kilograms per square metre
kg/t	kilograms per tonne
kJ	kilojoules
km	kilometres
km/h	kilometres per hour
kPaa	kilopascal - absolute
kPag	kilopascal - gauge

TABLE OF ABBREVIATIONS – UNITS OF MEASURE	
Unit	Description
<b>Metric</b>	
kW	kilowatt
kWh/t	kilowatt hour per tonne
L	Litre
L/h	Litres per hour
L/m	Litres per minute
MW	Megawatt
m	metre
m	metre
mg	milligram
m/d	metres per day
m/s	metres per second
m/s <sup>2</sup>	metres per second squared
µm	micron
micron	microns
mm	millimetre
mm	millimetre
mm Hg	millimetres of mercury
mm WC	millimetres Water Column
M	Million
ML/d	Million litres per day
Mt	Million metric tonne
min	minute (60 seconds)
ppm	parts per million
%	Percent
% solids	Percent solids by weight
rpm	revolutions per minute
s	second
SG	specific gravity
cm <sup>2</sup> /d	square centimetre per day
m <sup>2</sup>	square metre
mm <sup>2</sup>	square millimetres
K	Thousand (000)
t	tonne (1,000 kg) (metric tonne)
tpa	tonnes per annum



<b>TABLE OF ABBREVIATIONS – UNITS OF MEASURE</b>	
<b>Unit</b>	<b>Description</b>
<b>Metric</b>	
tpd	tonnes per day
tph	tonnes per hour
tpy	tonnes per year
V	Volt
W	Watt
Wk	week
wt%	weight percent
y	year (365 days)

## 1. SUMMARY

*Pursuant to an agreement between Falco and a Third Party, Falco owns rights to the minerals located below 200 metres from the surface of mining concession CM-156PTB, where the Horne 5 deposit is located. Falco also owns certain surface rights surrounding the Quemont No. 2 shaft located on mining concession CM-243. Under the agreement, ownership of the mining concessions remains with the Third Party.*

*In order to access the Horne 5 Project, Falco must obtain one or more licenses from the Third Party, which may not be unreasonably withheld, but which may be subject to conditions that the Third Party may require in its sole discretion. These conditions may include the provision of a performance bond or other assurance to the Third Party and the indemnification of the Third Party by Falco. The agreement with the Third Party stipulates, among other things, that a license shall be subject to reasonable conditions which may include, among other things, that activities at Horne 5 will be subordinated to the current use of the surface lands and subject to priority, as established in such party's sole discretion, over such activities. Any license may provide for, among other things, access to and the right to use the infrastructure owned by the Third Party, including the Quemont No. 2 shaft (located on mining concession CM-243 held by such Third Party) and some specific underground infrastructure in the former Quemont and Horne mines.*

*Furthermore, Falco will have to acquire a number of rights of ways or other surface rights in order to construct the TMF and associated pipelines.*

*While Falco believes that it should be able to timely obtain the licenses from the Third Party and to acquire the required rights of way and other surface rights, there can be no assurance that any such license, rights of way or surface rights will be granted, or if granted will be on terms acceptable to Falco and in a timely manner.*

*Falco also notes that the timeline of activities described in this Report, and the estimated timing proposed for commencement and completion of such activities, is subject at all times to matters that are not within the exclusive control of Falco. These factors include the ability to obtain, and to obtain on terms acceptable to Falco, financing, governmental and other third party approvals, licenses, rights of way and surface rights (as described in Chapters 16, 18 and 20).*

*Although Falco believes that it has taken reasonable measures to ensure proper title to its assets, there is no guarantee that title to any of assets will not be challenged or impugned.*

*The foregoing disclaimer hereby qualifies in its entirety the disclosure contained in this Report.*

The Horne 5 Gold Project, herein also referred to as the “Project”, is a gold exploration project located in Rouyn-Noranda, Québec, Canada.

Falco requested that BBA Inc. (“BBA”) prepare a technical report (the “Report”) of the Feasibility Study, herein also referred to as the “FS” or the “Study”, for the Project. This Report was completed with the assistance of a number of specialized consultants, including InnovExplo Inc. (“InnovExplo”), Golder Associates Ltd. (“Golder”), WSP Canada Inc. (“WSP”), SNC-Lavalin Stavibel Inc. (“SNC-Lavalin”) and Ingénierie RIVVAL Inc. (“RIVVAL”). This Report was prepared according to the guidelines set out under the requirements of National Instrument 43-101 Standards of Disclosure for Mineral Projects (“NI 43-101”) to support the results of the Study as disclosed in Falco’s press release entitled “Falco Announces Positive Feasibility Study Results on Horne 5 Gold Project”, dated October 16, 2017. The major Study contributors and their respective areas of responsibility are presented in Table 1-1.

**Table 1-1: Major contributors to the Feasibility Study**

Consulting Firm or Entity	Area of Responsibility
BBA	<ul style="list-style-type: none"> <li>▪ Metallurgical testwork analysis, processing plant design;</li> <li>▪ Process plant capital costs and operating costs;</li> <li>▪ Electrical and IT infrastructure design and costs (supply and on-site);</li> <li>▪ Market studies and contracts;</li> <li>▪ General and administration operating costs;</li> <li>▪ Financial Analysis and overall NI 43-101 integration.</li> </ul>
InnovExplo	<ul style="list-style-type: none"> <li>▪ Current and historical geology, exploration, drilling, sample preparation and QA/QC, and data verification;</li> <li>▪ Geological modelling and mineral resource estimate;</li> <li>▪ Mineral reserves estimate;</li> <li>▪ Underground mine design, underground infrastructure and material handling, ventilation, production scheduling, underground capital costs and operating costs, void evaluation;</li> <li>▪ Historical data review.</li> </ul>

Consulting Firm or Entity	Area of Responsibility
Golder	<ul style="list-style-type: none"> <li>▪ Waste rock, tailings, mineralization and water geochemical characterization;</li> <li>▪ WTP design, capital and operating costs;</li> <li>▪ Underground high density sludge, slurry and paste backfill and slurry tailings distribution systems design and costs;</li> <li>▪ Surface tailings and waste rock management facility and water management designs and costs, including closure costs;</li> <li>▪ Surface tailings, reclaim and fresh water transport system design and costs;</li> <li>▪ Mine site water management infrastructure design and costs;</li> <li>▪ Rock mass characterization and rock mechanics input to underground mine design and ground control;</li> <li>▪ Hydrogeology input to underground mine design;</li> <li>▪ Geotechnical input for the surface infrastructure design.</li> </ul>
WSP	<ul style="list-style-type: none"> <li>▪ Environmental studies, permitting, mine closure requirements and Horne 5 Mining Complex closure costs;</li> <li>▪ Regulatory context, social considerations, and anticipated environmental issues;</li> <li>▪ Headframe and hoist room design and costs;</li> <li>▪ Shaft design and associated underground work and costs;</li> <li>▪ Ore handling system from underground mine (Phase 1) to surface stockpile, design and costs;</li> <li>▪ Paste backfill plant design, capital and operating costs.</li> </ul>
SNC-Lavalin	<ul style="list-style-type: none"> <li>▪ Existing infrastructure, municipal infrastructure and relocation, design and costs;</li> <li>▪ Site access road, security gate and light vehicle road design and costs;</li> <li>▪ First-aid and emergency services, costs;</li> <li>▪ Site utilities design and costs.</li> </ul>
RIVAL	<ul style="list-style-type: none"> <li>▪ Railway engineering design and costing.</li> </ul>

All monetary units in the Study are in Canadian dollars (CAD or \$), unless otherwise specified. Costs are based on second quarter (Q2) 2017 dollars.

## 1.1 Key Project Outcomes

The following list details the key project outcomes as determined from the Study:

- Mine life of approximately 15 years with peak-year gold production of 268,000 ounces and average LOM (“life of mine”) annual payable gold production of approximately 219,000 ounces;
- Production of 3,338,965 ounces of gold over the LOM from 81 Mt of ore, with an average diluted grade of 1.44 g/t Au;
- 2.37 g/t AuEq average diluted gold grade equivalent;
- 3,294,197 ounces of payable gold over LOM;
- 1,007 million pounds of payable zinc over LOM;
- 229 million pounds of payable copper over LOM;
- 26.3 million ounces of payable silver over LOM;
- Net payable gold recovery of 88.1%;
- Net payable silver recovery of 71.5%;
- Net payable copper recovery of 75.8%;
- Net payable zinc recovery of 72.9%;
- Gross revenue (“NSR”) of \$7.85 billion and total operating costs and royalties of \$3.47 billion;
- All-in sustaining costs<sup>(1)</sup> of 399 USD/oz net of by-product credits, including royalties, over LOM, generating an operating margin of over 901 USD/oz or 69%;
- All-in cost (CAPEX plus OPEX) is estimated at 643 USD per payable ounce;
- Initial capital costs of \$1,028 million, including a \$75 million contingency and less \$34.3 million of capital outlays to August 31, 2017;
- NPV of \$1,297 million at a 5% discount rate and an IRR of 18.9% before taxes and mining duties;
- NPV of \$772 million at a 5% discount rate and an IRR of 15.3% after taxes and mining duties;
- Payback period of 5.2 years pre-tax and 5.6 years post-tax;
- Approximately 950 workers during the peak construction period and up to 502 employees, staff and labour, will be required during operations;
- Process plant commissioning in Q2 2021; fully operational by Q3 2021;
- Full mine production in first half of 2022.

<sup>(1)</sup> All-in Sustaining Costs are presented as defined by the World Gold Council (“WGC”) less Corporate G&A.

## 1.2 Property Description, Location and Access

The Falco property (the “Property”) is located in the Abitibi region, in the central-northwest part of the province of Québec, Canada. The approximate coordinates of the geographic centre of the Horne 5 deposit are 79° 00' 35" W and 48° 15' 15" N (UTM coordinates: 647746 E and 5346475 N, NAD 83, Zone 17). Figure 1-1 shows the location of the Project site.

The Horne 5 Mining Complex will be located on the site of the former Quemont mine, located within the urban limits of the City of Rouyn-Noranda in Rouyn Township, while the surface tailings management facility (“TMF”) will be located at an existing TMF site approximately 11 km northwest of the Horne 5 Mining Complex site. Due to the Project’s urban location, excellent infrastructure, i.e. electricity, rail, water etc., is available and the site is easily accessible year-round via Provincial Highways 117 and 101.

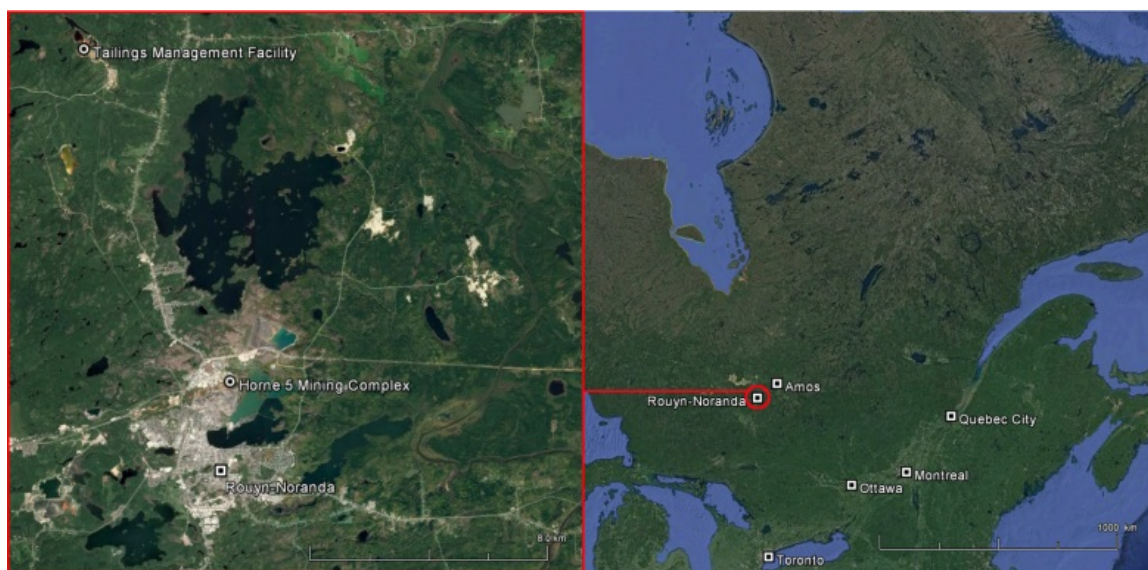

Figure 1-1: Horne 5 Project location in Québec

## 1.3 Land Tenure, License Agreements and Royalties

The portfolio of properties, with respect to which Falco holds certain rights, consists of 2,114 mining claims and 17 mining concessions in non-contiguous blocks covering an aggregate surface area of 68,945.54 hectares (689.5 km<sup>2</sup>). All the mining claims are registered under the name of Falco and/or certain joint venture partners (except for 31 claims registered under the name of Glencore Canada Corporation (“Glencore Canada”, the “Third Party”). The 17 mining concessions are registered under the name of Glencore Canada. Certain mining titles are subject to a number of agreements.

The Property is divided into five parts, as described in the purchase agreement of September 12, 2012, between Xstrata Canada Corporation (now Glencore Canada) and Falco, as follows:

1. “Horne Mines Ltd Controlled Properties”
2. “Lac Montsabrais Property”
3. “Noranda Properties”
4. “Third Party Interest Properties”
5. “West Ansil Discovery Property”

Mining concession CM-156PTB (the “Concession”), on which lies the Horne 5 deposit, is part of the Controlled Properties. The Concession has an irregular shape and a surface area of 191.96 hectares.

Mining concession CM-243 (“Concession 243”), on which lies the Quemont No. 2 shaft, is part of the Controlled Properties. The Concession 243 has a surface area of 224.90 hectares.

In the opinion of the QPs, the following interpretations and conclusions are valid:

- Pursuant to an agreement between Falco and the Third Party, Falco owns rights to the minerals located below 200 metres from the surface of the Concession, where the Horne 5 deposit is located. Falco also owns certain surface rights surrounding the Quemont No. 2 shaft located on the Concession 243. Under the agreement, ownership of the Concession and Concession 243 remains with the Third Party;
- Glencore Canada owns the mining rights to the Concession and to Concession 243 including 100% of the rights to the minerals contained between the surface and a depth of 200 m below the surface;
- The Concession is subject to a 2% NSR Royalty in favour of Glencore Canada;
- Permitting and license agreements with mining rights owner Glencore Canada is necessary if Falco is to perform exploration work or mining activities on the Concession and Concession 243;
- The Concession and Concession 243 is located within an urbanized perimeter;
- Except pursuant to licenses granted by Glencore Canada, as applicable, Falco is not responsible for any environmental liability relating to the surface rights, the mineral rights and the minerals contained at a depth of less than 200 m below the surface of the Concession and Concession 243. However, upon commencement of the development and operations at Horne 5, Falco will have statutory environmental liabilities for such operations.



## 1.4 Property History

From 1934 to 1976, multiple exploration works, i.e. drilling and developments, were done to delimit and develop the Horne 5 deposit. Since this time, numerous resource estimates have been produced based on varying depths and drilling methods.

In March 2013, Falco retained InnovExplo to complete a digital model of the Horne 5 deposit. The model incorporated 370 level plans, 620 cross-sections, 99 longitudinal sections, over 4,300 drill holes and over 150,000 assay results. Modelling also included more than 55,000 m of Noranda's underground development on 22 levels and 18 sublevels, which was carried out between 1931 and 1976, during the exploration of the Horne 5 deposit. Since this time, various drilling campaigns were undertaken and mineral resource estimates were conducted.

## 1.5 Sample Preparation, Analyses and Security

The historical information used in this FS was taken from reports produced before the implementation of NI 43-101. No information about sample preparation, analytical or security procedures is available in the reviewed historical documents. InnovExplo assumes that the exploration activities conducted by earlier companies were in accordance with prevailing industry standards at the time.

The results of confirmation and exploration drilling programs conducted by Falco in 2015 and 2016 were used for the current mineral resource estimate update (the "October 2017 MRE"). InnovExplo reviewed the following aspects related to these campaigns: laboratory accreditation and certification, sample preparation descriptions, analytical method descriptions and quality assurance/quality control ("QA/QC") protocols. The drill core was boxed, covered and sealed at the drill rigs, and transported by the drilling personnel to the logging facility of Services Technominex Inc. ("Technominex") in Rouyn-Noranda, Québec, where their personnel took over the core handling.

## 1.6 Data Verification

The October 2017 MRE is largely supported by historical data. A great deal of effort was made during the data validation process to obtain the highest degree of confidence possible in terms of dataset quality and precision. Data validation was performed on the two phases of historical underground drill hole compilations carried out by Falco in 2013 and 2014. Assays were verified against digital versions of the original paper logs provided by Falco, because none of the certificates of analysis were available for the historical drill holes.

The first drill hole database was compiled by Falco from original logs, dated from 1931 to 1976, and includes the collar locations, down hole surveys, assays and iron contents for 4,384 diamond drill holes ("DDH"). InnovExplo's data verification, conducted from 2013 to 2014, included a review of drill hole collar locations, down hole surveys, assays and iron contents, and a validation



of the conversion formula from iron to specific gravity. To complete the data verification on the first compilation phase, InnovExplo re-sampled selected intervals from 16 DDH available at the Horne core storage site. The intervals were selected based on their metal contents.

The second drill hole database was compiled by Falco from original logs, dated from 1931 to 1976. InnovExplo's data verification, conducted in 2014, included a review of drill hole collar locations, down hole surveys and assays. More than 90% of the drill hole collar locations and down hole surveys were validated using georeferenced vertical sections and level plan views.

Channel samples were compiled and digitized by InnovExplo from available historical plans. These historical plans were presented in Noranda's local mine grid system. Channel sampling confirms the local geological and grade continuities observed in the historical and 2015-2016 drill holes. Channel sampling information improved the accuracy of the interpretation of mineralized zones in the Horne 5 deposit.

InnovExplo conducted comparisons between historical drill hole composites and historical channel composites. The comparisons show a very good correlation between the grade of DDH samples and the grade of corresponding channel samples.

InnovExplo's data verification, performed from 2013 to 2016, increased the confidence of the different data sets supporting the October 2017 MRE, particularly in terms of geometry, geological continuity and grade continuity for the mineralized zones defined in the Horne 5 deposit.

## 1.7 Mineral Processing and Metallurgical Testing

An extensive metallurgical testwork program was undertaken on samples prepared from seven drill holes obtained from the Horne 5 deposit. The testwork consisted of chemical and mineralogical characterization, a preliminary evaluation of comminution characteristics, a series of flotation and leaching tests as well as preliminary cyanide destruction and rheology tests. Using the results available to the end of December 2015, a metallurgical process flowsheet was proposed and recovery values for gold, silver, copper and zinc were determined for the calculation of the resource estimate. The results of subsequent testing conducted in 2016 and early 2017 were used to project the metal recovery values used for the FS design criteria and financial model.

The process flowsheet consists of differential flotation producing saleable copper and zinc concentrates, followed by a pyrite flotation step. The pyrite flotation concentrate undergoes a regrind and leaching to recover gold and silver. The overall gold and silver recoveries are increased by also leaching the pyrite flotation tailings ("PFT"). Both the leached pyrite concentrate and tailings are treated in separate carbon-in-pulp ("CIP") and cyanide destruction ("CND") circuits. The thickened pyrite concentrate tailings ("PCT") and the PFT are pumped, as required, to the paste backfill plant for further dewatering.

Based on the proposed flowsheet, the overall projected metallurgical recovery and net payable values for gold, silver, copper and zinc from the Horne 5 deposit are presented in Table 1-2.

Table 1-2: Projected metallurgical recoveries and net payable values for Au, Ag, Cu and Zn

Stage	Product	Cu (%)	Zn (%)	Au (%)	Ag (%)
Flotation	Cu concentrate	81.9	4.5	40.0	32.2
	Zn concentrate	-	86.2	1.7	11.7
	Py concentrate	-	-	52.3	47.5
	Py tails	-	-	6.1	8.6
Leaching	Py concentrate	-	-	85.0	78.6
	Py tailings	-	-	77.6	65.2
<b>Overall Metallurgical Recovery (%)<sup>(1)</sup></b>		<b>81.9</b>	<b>86.2</b>	<b>90.9</b>	<b>85.1</b>
<b>Net Payable (%)<sup>(2)</sup></b>		<b>75.8</b>	<b>72.9</b>	<b>88.1</b>	<b>71.5</b>

<sup>(1)</sup> Metallurgical recovery based on LOM averages of yearly projections, including payable metal department to saleable concentrates and doré from leaching.

<sup>(2)</sup> Net payable percentages reflect payments and deductions for smelting and refining in the NSR estimate as well as bullion refiner's deductions.

## 1.8 Mineral Resource Estimate

The October 2017 MRE, effective as of July 25, 2017 and presented herein, was prepared by Carl Pelletier, P.Geo., using all available information. The main objective was to update the previous NI 43-101 mineral resource estimate for the Horne 5 deposit, which was prepared by InnovExplo and published in a report titled "Technical Report and Updated Mineral Resource Estimate for the Horne No. 5 Deposit", dated November 7, 2016 (Pelletier et al., 2016) (the "November 2016 MRE").

The October 2017 MRE is mainly based on changes made to the net smelter return ("NSR") parameters, supported by new assumptions concerning metal prices and net recoveries. Three additional DDH and 41 updated downhole surveys from the 2015–2016 confirmation drilling program were also used in this October 2017 MRE. No changes to the interpretation were deemed necessary.

The mineral resources presented herein are not mineral reserves as they have no demonstrable economic viability. The interpretation of mineralized zones was updated using a total of 5,980 additional DDH and 14,799 channel samples. The resource model is based largely on the model generated on past mineral resource estimates and complemented by two additional mineralized envelopes and one additional high-grade subzone. The result of this Report is a single mineral resource estimate for six mineralized envelopes: ENV\_A, ENV\_B, ENV\_C, ENV\_D, ENV\_E and ENV\_F. The distribution of metal contents in the main mineralized envelope (ENV\_A) defines 11 high-grade subzones: six for gold (HG\_A to HG\_F), one for copper (Cu\_HG), one for zinc

(Zn\_HG) and three for silver (HG\_D, HG\_F and SG\_HD). The October 2017 MRE includes Measured, Indicated and Inferred mineral resources for an underground volume.

The October 2017 MRE was made using 3D block modelling and the inverse distance square interpolation (“ID<sup>2</sup>”) method in a wireframe model of the Horne 5 deposit. The model has a strike length of 800 m, a width ranging from 7 m to 120 m, and a vertical depth from 600 m to 2,600 m below surface.

The GEMS DDH database contains 11,040 DDH. The October 2017 MRE uses 5,980 holes in the database, totalling 483,254 m (220,087 samples), with the remaining holes being too far from the deposit to be of use for the estimate. Of this total, 5,938 are historical underground DDH with specific gravity data and accompanying gold, copper and zinc assay results obtained by conventional analytical methods. The historical underground DDH cover the length of the deposit at a fairly regular drill spacing of 15 m in a radiating (fan) pattern from 40 underground working levels and sublevels (see Figure 14-2).

The database also includes the results of 34 DDH from the 2015–2016 confirmation drilling program that intersect the Horne 5 deposit. Another eight DDH drilled close to the Horne 5 deposit during the 2015–2016 exploration program have also been included.

Given the nature of the data, the density of the processed data, the search ellipse criteria and the specific interpolation parameters, InnovExplo is of the opinion that the October 2017 MRE can be classified as Measured, Indicated and Inferred mineral resources. Mineral resources in the Measured category are reported for the first time on the Horne 5 Project. The NSR cut-off is supported by economic assumptions defined in the Preliminary Economic Assessment (“PEA”) prepared by BBA, dated June 23, 2016 (Hardie et al., 2016) (the “2016 PEA”). The October 2017 MRE also used an updated NSR calculation supported by new assumptions concerning metal prices, net recoveries and smelting costs.

The October 2017 MRE is compliant with CIM standards and guidelines for reporting mineral resources and reserves. The selected NSR cut-off of 55 \$/t allowed the mineral potential of the deposit to be outlined for an underground mining option. While the results are presented undiluted and in situ, the reported mineral resources are considered by the QP to have reasonable prospects for economic extraction.

The results of the October 2017 MRE at the base case cut-off of \$55 NSR are presented in Table 1-3. InnovExplo estimates the Horne 5 deposit contains, based on an NSR cut-off of 55 \$/t, Measured mineral resources of 9,259,600 t at 2.59 g/t AuEq (gold equivalent) for a total of 769,885 oz AuEq, Indicated resources of 81,855,200 t at 2.56 g/t AuEq for a total of 6,731,443 oz AuEq, and Inferred resources of 21,500,400 t at 2.51 g/t AuEq for a total of 1,735,711 oz AuEq.

Table 1-3: Horne 5 mineral resource (July 25, 2017)

Mineral Resource Category	Tonnes (Mt)	AuEq (g/t)	Au (g/t)	Ag (g/t)	Cu (%)	Zn (%)	Contained AuEq (Moz)	Contained Au (Moz)	Contained Ag (Moz)	Contained Cu (Mlbs)	Contained Zn (Mlbs)
Measured	9.3	2.59	1.58	16.2	0.19	0.83	0.770	0.470	4.824	38.0	168.5
Indicated	81.9	2.56	1.55	14.74	0.18	0.89	6.731	4.070	38.796	325.4	1,599.3
Inferred	21.5	2.51	1.44	23.04	0.20	0.71	1.736	1.000	15.925	96.3	337.2

Notes:

- The effective date of the resource estimate is July 25, 2017. The Independent and QP for the Mineral Resource Estimate as required by National Instrument 43-101 is Carl Pelletier, P. Geo., B.Sc., employee of InnovExplo Inc.
- Mineral resources are not mineral reserves and do not have demonstrated economic viability.
- While the results are presented undiluted and in situ, the reported mineral resources are considered by the QP to have reasonable prospects for economic extraction.
- These estimates include six low-grade gold-bearing mineralized envelopes.
- The main low-grade gold-bearing mineralized envelope includes six high-grade gold-bearing zones, one high-grade copper-bearing zone, one high grade zinc-bearing zone, and three high-grade silver-bearing zones. Note that these high-grade zones may overlap each other.
- Resources were compiled at NSR cut-offs of \$40, \$45, \$50, \$55, \$60, \$65, \$70, \$75, \$80, \$85, \$90, \$95 and \$100 per tonne for sensitivity purposes.
- The official base case resource is reported at a 55 \$/t NSR cut-off.
- The appropriate NSR cut-off will vary depending on prevailing economic and operational parameters to be determined.
- NSR estimates are based on the following assumptions: Exchange rate of 1.28 CAD/1.00 USD; Metal prices as follows: gold 1,300 USD/oz, silver 19.50 USD/oz, copper 2.90 USD/lb, zinc 1.10 USD/lb (inspired from a long-term analyst consensus price forecast study); Net recoveries are variable in function of grade of each commodity. Smelting cost (including transportation) of 6.52 \$/t (based on the Mining Cost Service, as well as a non-public smelter contract obtained from one of the proposed destinations and talks with transport providers).
- Gold equivalent calculations assume these same metal prices.
- Inferred mineral resources are separate from Indicated mineral resources.
- The quantity and grade of reported Inferred mineral resources are uncertain in nature and there has not been sufficient work to define these Inferred mineral resources as Indicated or Measured mineral resources. It is uncertain if further work will result in upgrading them to an Indicated or Measured mineral resource category.
- The mineral resource was estimated using Geovia GEMS 6.8. The estimate is based on 5,980 DDH (483,254 m) of which 4,141 cut mineralized zones for a total of 178,150 m of core within these zones. For silver, the estimate also uses the results of an exhaustive metallurgical test comprising 2,112 DDH assayed for silver over a total length of 75,540 m. A minimum true thickness of 7.0 m was applied, using the grade of the adjacent material when assayed, or a value of zero when not assayed. Only the silver interpolation in the Inferred resources does not use the material when not assayed.
- The estimate database also contains 14,799 channel samples for a total of 23,791 m from historically sampled drifts. Channel sample data was only used for distance to composite criterion for resource classification purposes.
- 91% of density values were estimated using historical iron assay drill hole data and Falco density data for an average of 3.41 g/cm<sup>3</sup>. The interpolation method uses three passes for the ENV\_A and HG\_A to HG\_F zones. 8% of the density values were fixed at 2.88 g/cm<sup>3</sup> for ENV\_B to ENV\_E due to the scarcity of the data. 2.88 g/cm<sup>3</sup> represents the median of the available data. 1% of density values were fixed at 2.67 g/cm<sup>3</sup> for ENV\_F due to the scarcity of the data and to adequately characterize this quartz-rich zone.
- Compositing was done on drill hole sections falling within the mineralized zones (composite = 3.0 m). Tails shorter than 0.75 m were not generated.
- Resources were evaluated from drill holes using an ID<sup>2</sup> interpolation method in a block model (block size = 5 x 5 x 5 m).
- High-grade capping was done on raw assay data and established on a per zone basis for gold (Au g/t): (HG\_A: 35; HG\_B: 35; HG\_C: 25; HG\_D: 35; HG\_E: 25; HG\_F: 35; ENV\_A: 35; ENV\_B: 25; ENV\_C: 25; ENV\_D: 20; ENV\_E: 35; ENV\_F: 25) and for silver (Ag g/t): SG\_HG:100; HG\_D: 165; HG\_F: 165; ENV\_A\_SG\_Low: 110; ENV\_B: 100; ENV\_C: 100; ENV\_D: 100. Capping grade selection is supported by statistical analysis. No capping was applied to the Cu and Zn data based on statistical analysis.
- The reported mineral resources are categorized as Measured, Indicated and Inferred. The Inferred category is only defined within the areas where blocks were interpolated during pass 1 or pass 2 in areas where continuity is sufficient to avoid isolated blocks. The Indicated category is only defined by blocks interpolated in areas where the maximum distance to the closest drill hole composite is less than 25 m for blocks interpolated in passes 1 and 2. The Measured category is only defined by blocks classified as Indicated and within sufficient proximity to sampled drifts (<15 m). The average distance to the nearest composite is 6.97 m for the Measured mineral resources, 10.01 m for the Indicated resources and 40.10 m for the Inferred mineral resources.
- Tonnage estimates were rounded to the nearest hundred tonnes. Any discrepancies in the totals are due to rounding effects. Rounding practice follows the recommendations set forth in Form 43-101F1.
- CIM definitions and guidelines were followed in estimating mineral resources.
- InnovExplo is not aware of any known environmental, permitting, legal, title-related, taxation, socio-political, marketing or other relevant issue that could materially affect the mineral resource estimate, other than the third party approvals previously mentioned.
- Metal contained in ounces (troy) = metric tonnes x grade / 31.10348. Calculations used metric units (metres, tonnes and g/t). Metal contents are presented in ounces and pounds.

## 1.9 Mineral Reserve Estimate

The mineral reserves estimate (Table 1-4) for the Horne 5 Project was prepared by Mr. Patrick Frenette P.Eng., an employee of InnovExplo Inc., and is effective as of August 26, 2017. The mineral reserves estimate stated herein is consistent with the CIM Standards on Mineral Resources and Mineral Reserves and is suitable for public reporting. As such, the mineral reserves are based on Measured and Indicated resources, and do not include any Inferred mineral resources. Measured and Indicated mineral resources are inclusive of Proven and Probable mineral reserves.

The Feasibility Study LOM plans and mineral reserves estimate were developed from the previous November 2016 MRE and does not consider the October 2017 MRE as presented in this Report. Updated metal prices, exchange rates and recovery equations from the October 2017 MRE were used however to calculate cash flows used to support the mineral reserve estimate. As of the date of this Report, the QP has not identified any risks, legal, political or environmental, that would materially affect potential development of the Mineral Reserves other than the third party approvals previously mentioned (see Section 15.1).

Table 1-4: Statement of mineral reserves (August 26, 2017)

Mineral Reserve Category	Tonnes (Mt)	NSR (\$)	Au (g/t)	Ag (g/t)	Cu (%)	Zn (%)
Proven	8.4	91.72	1.41	15.75	0.17	0.75
Probable	72.5	92.56	1.44	13.98	0.17	0.78
Proven + Probable	80.9	92.41	1.44	14.14	0.17	0.77

Notes:

1. The Qualified Person for the mineral reserve estimate is Mr. Patrick Frenette.
2. Mineral reserves have an effective date of August 26, 2017.
3. Estimated at 2.15 USD/lb Cu, 1.00 USD/lb Zn, 1,300 USD/oz Au and 18.50 USD/oz Ag, using an exchange rate of 1.30 CAD:USD, cut-off NSR value of 55.00 \$/t.
4. Mineral reserve tonnage and mined metal have been rounded to reflect the accuracy of the estimate and numbers may not add due to rounding.
5. Mineral reserves presented include both internal and external dilution along with mining recovery. The external dilution is estimated to be 2.3%. The mining recovery factor was set at 95% to account for mineralized material left in the margins of the deposit in each block.

## 1.10 Mining Methods

The proposed underground mine design supports the extraction of approximately 15,500 tpd average over the LOM of ore by transverse long-hole stoping, with primary and secondary stopes, with some areas being mined with the longitudinal mining retreat method. These mining methods are suitable, given the geometry, ground conditions and depth of the resources. Paste backfill is a key component for maximizing ore recovery and mining productivity. An ore recovery rate of 95% was applied to each mining stope. Individual dilution was calculated for each stope, giving an

average dilution of 2.3%. An 80% recovery factor was also added for the sills of Phase 2, to take into account any ground problems that could occur.

The mine has been designed to have low operating costs through the extensive use of automation, implementation of large modern remote controlled trackless equipment, gravity transport of mineralized material and waste through raises, shaft hoisting, minimal mineralized material and waste re-handling, and high productivity bulk mining methods.

For the Horne 5 deposit to be mined, the old excavations surrounding the mining area, including the interconnected historical Horne, Quemont and Donalda mines, must be dewatered. According to the preproduction schedule, the dewatering of the Horne 5 Project is expected to take approximately two years from the day pumping is initiated.

### 1.10.1 Geotechnical and Hydrogeological Considerations

The geotechnical assessment for the underground mine is based upon existing openings, the resource envelope, level plans and the geological model. Due to the proximity to the historical Horne mine workings, historical DDH and the planned mining depths, the following items have been identified as relevant for the rock engineering aspects of the Horne 5 deposit:

- The impact of mining induced stresses and seismicity;
- The impact of historical mining;
- The corrosion potential.

Geotechnical engineering design criteria was developed to support the underground mining production sequence and design. The geotechnical assessments made for the Horne 5 Project include:

- Rock mass characterization;
- Ground support requirements;
- Sill pillar design and placement;
- Stope sizing and logistics;
- Backfill strength assessment;
- Rock mass monitoring.

Fieldwork studies were performed in the summer of 2015 and autumn of 2016 to determine the hydrogeological conditions on the Horne 5 Mining Complex site. The tests performed consisted of a packer test profile and the implementation of nine observation wells at four different locations. Based on the hydrogeological design basis developed, groundwater inflows were estimated and thus dewatering flow rate values were calculated.

### 1.10.2 Mine Design

The Quemont No. 2 shaft will be rehabilitated to accommodate a LOM average production rate of approximately 15,500 tpd and will provide the principal access to the deposit. The shaft is designed to operate two 43 t skips, one double-deck service cage, one double-deck auxiliary cage and services for the underground mine. The hoisting capacity of the rehabilitated shaft is 23,180 tpd for Phase 1 and 16,530 tpd for Phase 2. The shaft design calls for the rehabilitation of 24 existing stations, five of which will be used during production. Upon completion of shaft deepening, an additional five stations will be built. A total of ten stations will be used in mine Phases 1 and 2.

Four main levels connect the Quemont No. 2 shaft and Horne 5, and production levels are connected by a main decline from the top to the bottom of the deposit. The proposed mine plan for the Horne 5 Project is divided into two production phases characterized by separate accesses to the mineralized zones:

- Phase 1: From surface to level 1310, near the bottom of the current Quemont No. 2 shaft, located on level 1230;
- Phase 2: From level 1340 to level 2060, after deepening the Quemont No. 2 shaft.

A fleet of 14 t LHDs and 55 t trucks will be required for underground infrastructure development.

For extracting, the automated 21 t LHDs will dump directly from the stope to the ore pass; two main ore passes will then transfer material from the production area to two loading stations on levels 1180 and 1910.

For each phase, the ore passes will be connected to grizzlies and rock breaker facilities, which then lead to two primary crushers for Phase 1 and one primary crusher in Phase 2. In both cases the crusher product feeds a single conveyor that transports the ore from the Horne 5 mine to the Quemont No. 2 shaft loading facilities. Below level 1910, 55 t trucks will be used for haulage in the main ramp from level 2060 to level 1910.

Key mine infrastructure includes a paste backfill distribution network, five main pumping stations, a fuel distribution network, a main garage for equipment, electrical substations and other installations such as powder magazines and refuges. Figure 1-2 provides an overview of the proposed mine layout and infrastructure.

Three master communication networks will be installed from surface to every underground level. The first is a leaky feeder cable to provide voice communication throughout the mine, the second is the “FEMCO” security system deployed at every refuge and strategic site, and the third is the fiber optic network that will be brought to every electrical substation, pump station, crushing station and conveying site. Each level will have Wi-Fi distribution and a network access point through the leaky feeder network.



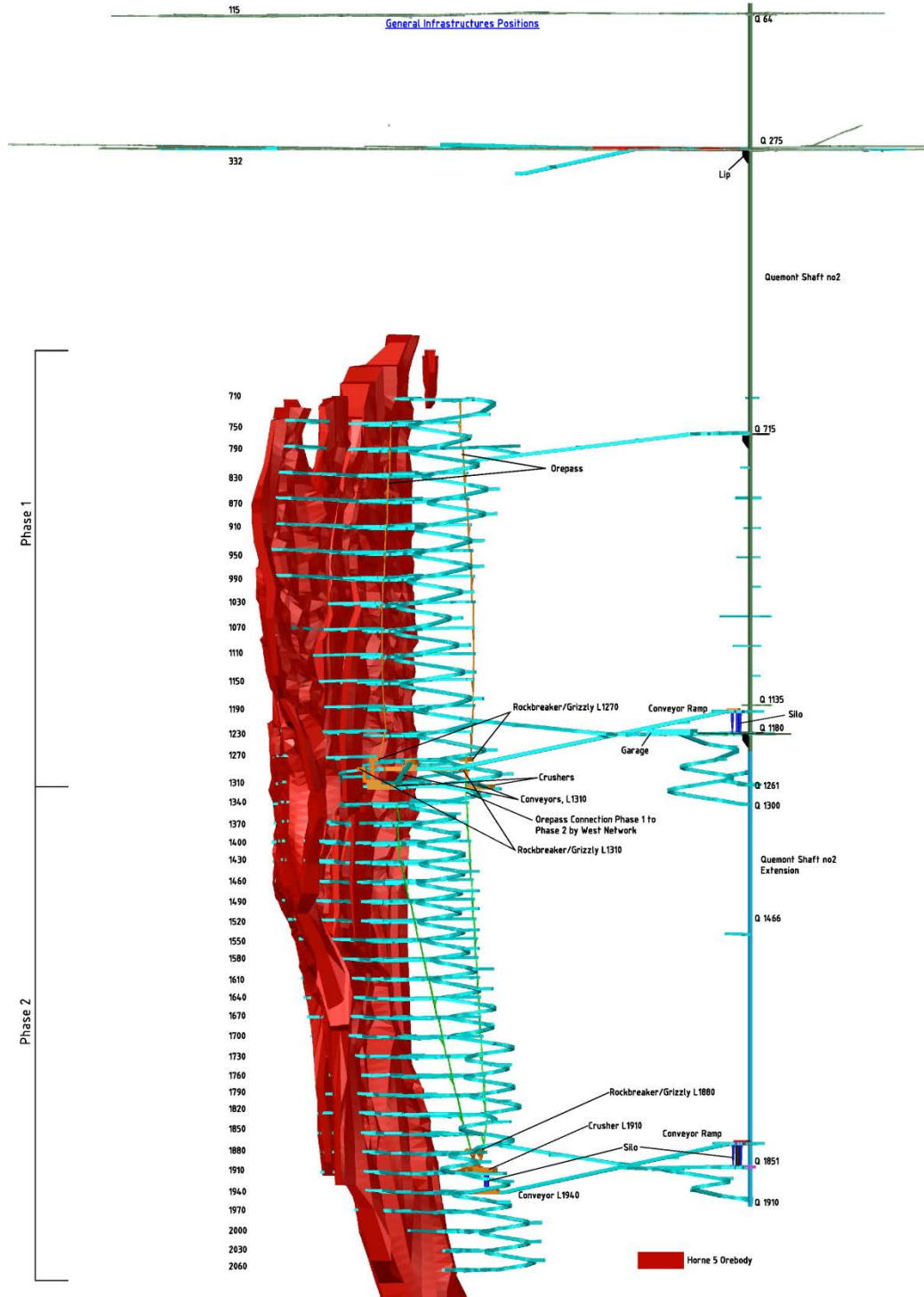

Figure 1-2: Underground mine infrastructure



### 1.10.3 Mine Dewatering and Rehabilitation

Dewatering from surface will first be carried out from the Horne No. 4 shaft, Quemont No. 2 shaft and Donalda shaft collars. In each case, a surface set-up will manage the submersible pumps. The pumps will be lowered down the shafts to a depth of between 100 m and 375 m from the collar. The combined water pumping rate sent to the water treatment plant (“WTP”) at surface will be at a maximum of 600 m<sup>3</sup>/h. Several submersible, high-volume, high-pressure stainless steel pumps will be required to remove water from the historical mines. These pumps can be remotely lowered down the shafts without any installation in the shaft.

- The Horne No. 4 shaft installation consists of two 400 hp submersible pumps that are installed from the surface to a maximum of 230 m deep with rigid piping set-up;
- Quemont No. 2 shaft installation consists of one 400 hp submersible pump to a depth of 275 m;
- Donalda shaft installation consists of one 250 hp submersible pump to a depth of 375 m.

Once the Quemont No. 2 shaft has been dewatered down to level Q275 by means of the surface installation, new submersible pumps will be installed underneath the Galloway, a multi-decked platform, to follow the rehabilitation of the shaft. Two 150 hp stainless steel pumps will feed a 500 hp multistage pump, installed directly on the Galloway deck, to direct the water to surface or to the main pumping stations.

All permanent installations for dewatering will be set up near the Quemont No. 2 shaft. As soon as levels Q275 (connecting with level 322), Q715 (connecting with level 790), and Q1180 (connecting with level 1190), are reached, the main clear water pumping stations will be built as a priority to support and contribute to the dewatering of the Quemont and Horne mines. As the Galloway is lowered and the Quemont No. 2 shaft is dewatered and rehabilitated, the main pumping stations will be used as boosters to bring the water to surface as they become available.

Drainage holes will be used to dewater the historical Horne mine via the Quemont No. 2 shaft and the installed pumping infrastructure. Drilling bays will be used to drain Horne water to the Quemont main pumping station. This system will securely drain high-pressure water by drilling 3 inch diameter holes about 250 m to reach historical Horne openings. The water from these drain holes will be directed to sumps and then pumped to the main pumping stations by means of submersible pumps.

### 1.10.4 Mine Services

Mine services include underground electrical distribution, automation and monitoring systems, fuel distribution, mine dewatering network and a ventilation network.

The ventilation system is a push-pull system. Permanent main fans on level 322 will provide fresh air to the mine. Fans in the headframe will feed the shaft to lower global pressure in the infrastructure. A total of 800,000 cfm is required for the mining operation. During preproduction, the old Quemont ventilation raise will be reused for development start-up. Two natural gas heating systems will be used during the winter months. Ventilation on demand (“VOD”) will be implemented to maximize the use of ventilation in working areas and thus lower requirements in other areas to help reduce energy costs.

### 1.10.5 Cemented Paste Backfill

Paste backfill is required for structural support in the mined out Horne 5 stopes. PFT, PCT and a pre-mix of cement and blast furnace slag will be used to produce the paste backfill for the underground mining operation. The estimated volumes of cemented paste backfill required are 0.46 Mm<sup>3</sup> and 0.18 Mm<sup>3</sup> for Phases 1 and 2, respectively. Over the life of mine of the Project, approximately 45% of all the tailings produced will be used in the paste backfill.

Two key aspects that influence the design of the underground distribution systems are the capacity of the paste plant and the mix recipe. The plant capacity will determine the flow rates for all of the process streams, whereas the mix recipe is determined to achieve the required backfill strength at the lowest binder content while maintaining a material that can be pumped or delivered by gravity.

The plant capacity selected for the Horne 5 Project is based upon the use of 12,065 tpd of dry tailings for the backfilling of mining voids generated by ore extraction in any given year. Such plant capacity allows an overall plant utilization of approximately 60%, which is typical for a paste backfill operation. Because the Horne 5 orebody is mostly dipping vertically, it is possible to distribute the paste by gravity and avoid the operation of a pumping system.

Extensive laboratory testing was completed to determine the optimal recipe to meet the geotechnical strength requirements. Laboratory tests on tailings performed by Golder and *Unité de recherche et de services en technologie minérale* (“URSTM”) confirmed that a mixture comprised of 50% PFT / 50% PCT at a 200 mm (8 in) slump was an appropriate mix design when using 80% blast furnace slag and 20% general use cement as the binder agent.

The paste plant design will include two parallel circuits and as a result, the paste backfill underground distribution system (“UDS”) is based upon operating a distribution line for each of the circuits. All piping and boreholes will be twinned for the paste distribution system. Redundancy will also be built into the system; thus, four boreholes will be drilled from surface to underground. For all interconnecting underground boreholes there will also be four boreholes; two operating and a spare for each.

### 1.10.6 Production Plan

Developing and maintaining access to sufficient resources to sustain the approximate 15,500 tpd average LOM production sequence will require an extensive underground development program averaging 7,000 m per year of jumbo advance, with a peak of 13,700 m in the final year of construction. A total of 129,100 m of lateral development will be required during the life of the mine.

The preproduction period will require 36 months from the onset of mine development, including the dewatering and rehabilitation sequence. Waste generated through infrastructure development will be disposed of in underground stopes, except during the preproduction period, where it will be transported to the TMF site and used as construction material. A total of 1.5 Mt of waste will be hoisted during that time.

Production will start in the third quarter of 2021 with a gradual ramp-up leading to full production in the beginning of 2022. Full production will continue until 2034. Production will then drop below 12,000 tpd in 2035 with depletion of Phase 2.

- Phase 1 will run from 2021 to 2029;
- Phase 2 will run from 2028 to 2035.

A total of approximately 81 Mt of ore, including development, will be hoisted over the life of the mine, at an average grade of 1.44 g/t Au, 0.17% Cu, 0.77% Zn and 14.14 g/t Ag.

### 1.10.7 Underground High Density Sludge, Slurry Tailings and Paste Backfill Distribution

During preproduction, i.e. the dewatering phase, and the initial years of operation until the TMF becomes available, the high density sludge (“HDS”) from the WTP and unused tailings for the production of paste backfill, will be stored in the old drifts and mine workings at the historical Donalda, Quemont and Horne mines. During preproduction, HDS and tailings will be stored in the Donalda and Quemont historical mines.

A significant portion of the tailings will be used as part of the paste backfill required for structural support in the Horne 5 mined-out stopes during production.

Cemented paste backfill will also be used to backfill the historical Horne mine on the levels where the Horne 5 development and mining activities will be intersecting the historical Horne drifts and voids during preproduction.

Tailings in excess of the paste backfill needs or generated while the paste backfill plant is not operating, will be stored in historical Horne mine openings as slurry. Based on the estimated underground storage capacity, tailings will be sent underground for a period of approximately two years, after which the remainder will be transported by pipeline to be stored at the TMF.

### 1.10.8 Mine Equipment and Personnel

The mine will operate seven days a week, night and day (24/7). Up to 333 people will be required for the production years (Phase 1), comprising 57 staff employees and 276 hourly employees. It is estimated that approximately 325 people will be required when the surface TMF is in operation.

A complete fleet of equipment will be needed to support mine operations and meet productivity requirements. A total of 77 units of mobile equipment are listed in this FS. Production equipment, such as production drills, LHDs and trucks, will be automated.

### 1.11 Process Plant

The processing facility will be used to process an approximate average of 15,500 tpd of mineralized material over the LOM. A schematic flowsheet is presented in Figure 1-3. The flowsheet consists of a semi-autogenous ball milling (“SAB”) circuit to grind primary crushed material to a target  $P_{80}$  size of 55-60 microns. The facility will have three flotation circuits to recover copper, zinc and pyrite concentrates. The copper and zinc circuits will see their respective concentrate filtered to reduce residual moisture content to approximately 10%. Both concentrates will be loaded for shipment to smelters: in trucks for the copper concentrate and railcars for the zinc concentrate.

The pyrite concentrate requires a finer regrinding stage, to a  $P_{80}$  of 12 microns, to achieve improved gold recovery by cyanide leaching. Both the pyrite flotation tailings and the reground pyrite concentrate will be leached separately before entering separate CIP circuits. Thickeners will be used to maximize water and cyanide recovery, and the Caro’s acid cyanide destruction method will be used to reduce the cyanide content of the two leach residues. A portion of the combined tailings will be used for paste backfill placement in the Horne 5 mine workings, while surplus tailings will initially be returned underground as well, but disposed of in existing historical openings. Bleed water liberated in the underground workings from the consolidated tailings will be recovered, recycled and pumped back to the process plant. At a later stage, once the historical mine openings are filled, a TMF will receive the excess tailings not used for paste backfill preparation.

The proposed process recovers zinc and copper concentrates, as well as gold and silver in the form of doré bars. The copper concentrate will have an estimated 16% copper content as well as payable gold and silver; the zinc concentrate will have an estimated 52% zinc content. Analysis of the copper and zinc concentrates produced at laboratory scale were free of deleterious elements and the eventual concentrate production from the full-scale facility is thus expected to be readily marketable to either smelters or traders.

The process plant facilities include a wet laboratory, offices, dry, maintenance shop and the paste backfill plant. A total of 93 personnel (including paste backfill operators) are required in the process plant, including 35 salaried staff and 58 hourly workers.

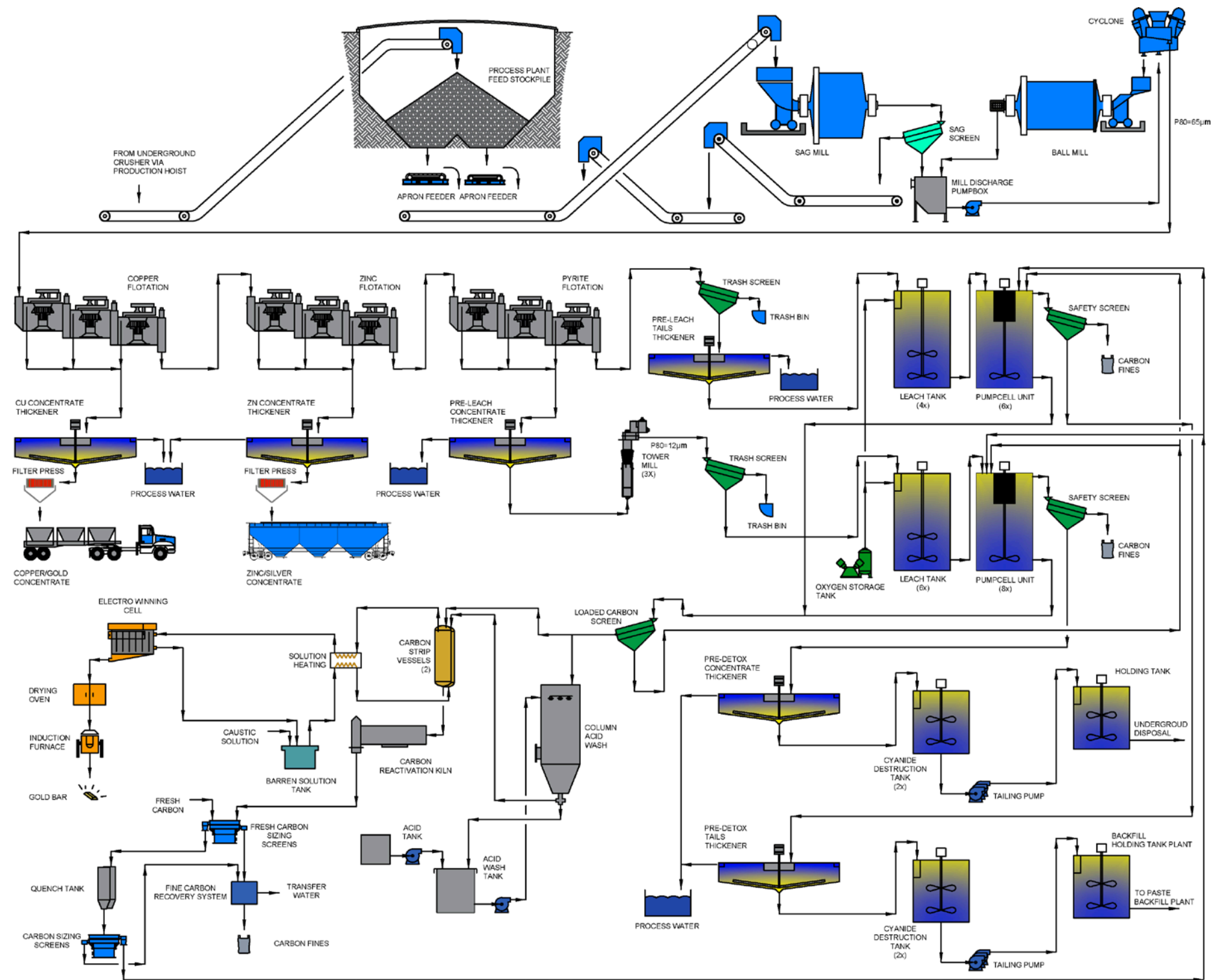

Figure 1-3: Simplified process plant flowsheet



## 1.12 Project Infrastructure

The Horne 5 surface infrastructure spans over two separate sites: the Horne 5 Mining Complex and the TMF, which is located approximately 11 km to the northwest. The two sites are connected via pipelines to allow for tailings disposal and water reclaim. Figure 1-4 shows the general layout of the Horne 5 Mining Complex.

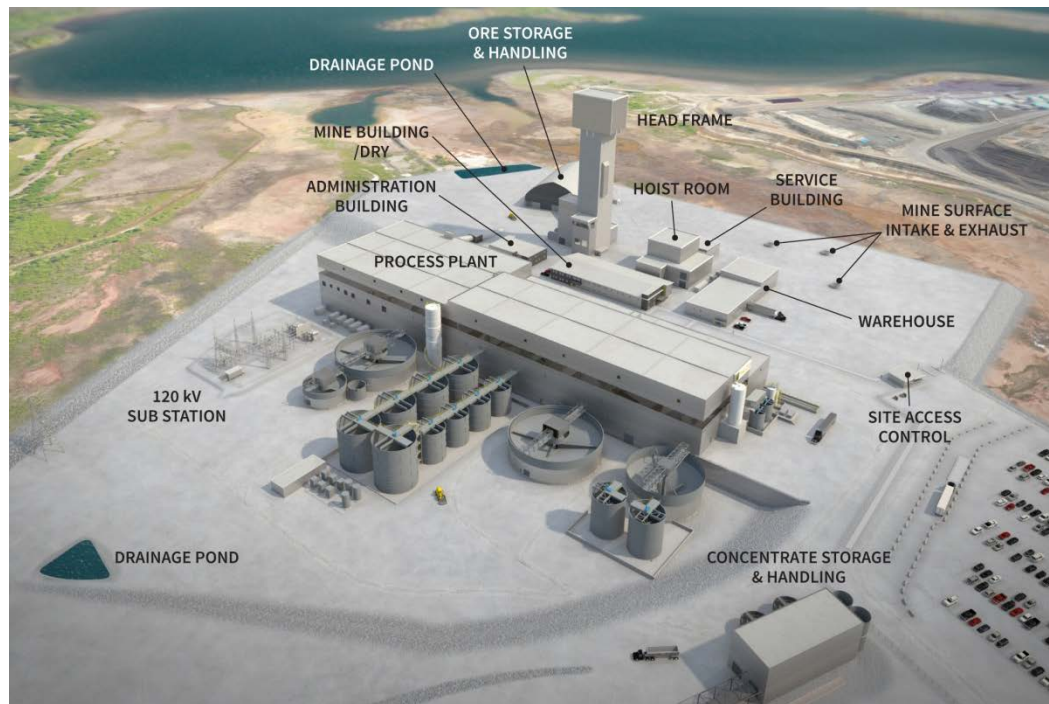

Figure 1-4: General site layout – Horne 5 Mining Complex

### 1.12.1 Geotechnical Studies

The main infrastructure to be constructed at the Horne 5 Mining Complex includes the process plant, head frame, hoist room, several thickeners and reservoirs located near the process plant, an ore storage reclaim tunnel and stockpile located in the southeast portion of the site, and an electrical substation located north of the process plant. A geotechnical study was conducted to confirm bedrock quality and depth throughout the site.

The head frame and hoist room will be built in the same location as the original head frame and hoist room for the Quemont No. 2 shaft and thus will be built directly on bedrock.

Existing site material will be excavated to bedrock for the preparation of the foundations of the process plant. Equipment will be installed directly on the surface of the rock or it will be built on controlled granular backfill. Pilings will be used for the concentrate loadout building.

## 1.12.2 Horne 5 Mining Complex

### Site Access Control

Access to the Horne 5 Mining Complex is planned to be from Marcel-Baril Avenue. This road will be modified to end at the site control gate and parking lot.

A control gate building and a fence will be erected at the main entrance of the site to supervise the personnel entrance and merchandise transport. Security personnel will ensure visitor registration and that all safety protocols are followed.

### Electrical Infrastructure

Electricity will be supplied to the site at a voltage level of 120 kV originating in the nearby Hydro-Québec, Rouyn-Noranda substation, located approximately 1 km away.

At the site, the outdoor substation will lower the incoming voltage to 25 kV, using two main transformers of 120-25 kV, 75/100/125 MVA each, for a combined firm power of 125 MVA. During normal operation, both transformers will share the loads, but during maintenance or repair work, one transformer will supply the entire site load, thus increasing the overall reliability of the electrical supply.

Considering the close proximity between buildings on the site, 25 kV power will be distributed using underground cables rather than overhead lines.

The power demand of the overall Horne 5 Mining Complex is approximately 93 MW. The calculated power demand was derived from the mechanical and process equipment list, without considering standby equipment and applying representative efficiency and load factors.

The following Table 1-5 shows the distribution of power by area/sector for the mining complex.

**Table 1-5: Power demand by area at the Horne 5 Mining Complex**

Area	Description	Connected Load (MW)	Power Demand (MW)
200	Underground Mine	10.5	5.9
300	Mine Surface Facilities	32.3	15.7
400	Electrical and Communication	0.5	0.25
500	Site Infrastructure	4.5	2.5
600	Main Process Plant	85.3	66.2
800	Tailings and Water Management	1.2	0.8
--	Electrical Network Losses (2%)		1.8
	<b>Total</b>	<b>134.3</b>	<b>93.2</b>

Two emergency diesel generator units (4.16 kV and 600 V) are planned to be located near the electrical substation for the purpose of supplying electricity to the critical process equipment/installations when the main power is lost. Another generator will be located near the hoist room and will be connected to the auxiliary hoist, allowing it to be used as an emergency escape for underground mine personnel.

### Hoist Room and Headframe

The hoist room located close to the headframe is designed to house the 5,500 mm double drum service hoist, driven by two 1,000 kW motors, and the 3,050 mm single drum auxiliary hoist, driven by one 1,000 kW motor. The hoisting plant main electrical room is located inside the hoist room building.

The 100 m high concrete headframe is designed to support the 6,500 mm friction production hoist and the 6,500 mm deflection sheaves. The 5,500 mm service sheaves and the 3,050 mm auxiliary sheaves are also located in the headframe. The ore stockpile is fed by a surface conveyor from a 300 t bin located in an annex of the headframe building.

### Process Plant

The process plant will be located adjacent to the mine office and dry building and approximately 80 m away from the mine hoist and headframe installations. The building will be 66 m wide by 235 m long, with a height of 32.5 m.

The main processing building will house the grinding area, i.e. SAG and ball mills, flotation cells, regrind mills, CIP, carbon stripping, electrowinning, refining and reagent preparation areas, as well as the paste backfill plant, tailings pumps, mechanical services, offices and metallurgical laboratory. The pre-leach thickeners, leach tanks, pre-detox thickeners, cyanide destruction tanks, lime and paste backfill binder silos are to be located outside the process plant.

### Warehouse and Service Building

The service building will consist of the renovated portion of the existing Sani-Tri building and located to the south of the new hoist room. The service building, including a maintenance bay, will cover an area of approximately 420 m<sup>2</sup>. The maintenance areas will also have access to a 5 t overhead crane. The warehouse will use a portion of the existing Sani-Tri building and will be renovated to serve its new purpose. It will cover an area of approximately 1,600 m<sup>2</sup>.

### Mine Office and Dry Building

The existing Quemont building that is sitting north of the proposed headframe location will serve as the administration and dry facility for the mine. The two-story plus basement building covers a surface area of 1,800 m<sup>2</sup>. The building will be renovated to meet the current codes and standards as well as meet Falco's esthetic requirements.



### Administration Building

A building that is currently being used by Lamothe, Div. of Sintra Inc. (“Lamothe”) and originally built for the Quemont mine will be used for the site administration offices. The building will also be renovated to meet current codes and standards, as well as to adhere to Falco’s architectural criteria.

### Railways

Railway transport will be used to minimize the carbon footprint of the Horne 5 Project and to facilitate the reception of inbound goods and reagents as well as manage the shipping of concentrates. A railway spur will be built to link the process plant concentrate loadout area to a new storage area for inbound and outbound cars that will connect directly to the existing Canadian National Railway Co. (“Canadian National”) rail line.

### Bulk Explosives Storage and Magazines

The average explosives consumption for the Horne 5 Project is estimated at 54 t per week; bulk emulsion will be used, given its urban setting. The explosives will be sent directly underground, which will reduce the supervision requirements and the risk of freezing during the winter months.

For these reasons, two major powder and cap magazines are planned underground with a capacity of over 50 t each. One is planned on level 1190 for Phase 1 of the mine plan and another on level 1880 for Phase 2.

The explosives will be brought underground using a service hoist and a dedicated compartment in the production shaft.

### Fuel Storage and Delivery

It is expected that 77,000 L of fuel will be delivered to the mine site each week. Assuming biweekly deliveries, the fuel surface tank must have a storage capacity of 40,000 L and it must be equipped with spill prevention features. Fuel will be sent underground in batches of 5,000 L, requiring the installation of two 5,000 L tanks: one on the surface and the other near the underground fuel storage tank. Batch production will be fully automated by controlling the pumps that produce the batches.

### Fire Water and Distribution System

Site fire hydrants as well as the surface buildings’ sprinklers will be supplied by an existing pipeline from Lac Dufault that is installed to the west of the Horne 5 Mining Complex. The main branch from the pipeline will feed booster pumps to be located in the process plant. The pumps will then feed one loop within the process plant and another underground line to service the buildings located to the south of Marcel-Baril Avenue.

### Potable Water

The potable water supply for the surface infrastructures will be connected to the City of Rouyn-Noranda's potable water system. The city's potable water system has the capacity to provide the Horne 5 Project's average water requirements of 39 m<sup>3</sup>/day as well as requirements during peak periods.

### Sewage Treatment

The wastewater sewage system for all surface infrastructures will be connected to the city of Rouyn-Noranda's sewage treatment system. The city's system can supply the sewage treatment requirements for the Horne 5 Mining Complex. A new 150 mm diameter by 180 m long sewage pipe will be installed on Marcel-Baril Avenue to accommodate the site requirements of 46 m<sup>3</sup>/day of sewage. All site surface water will be managed independently from the city's sewage system.

### Natural Gas

The natural gas supplied to the Horne 5 Mining Complex will originate from the existing Gaz-Métro network. An estimated 8.35 Mm<sup>3</sup> of natural gas will be consumed per year. Upgrades to the supply network will be required to accommodate the Horne 5 Project requirements.

### Fresh Water Pump House and Pipeline

A sea container consisting of two horizontal centrifugal pumps, one running and one spare, and an electrical room will serve as the fresh water pump house. It will be installed on Lac Rouyn to provide fresh water to the process plant. The fresh water pipeline will be approximately 7.1 km long.

### Site Infrastructure Relocation

There are existing buildings on the Horne 5 Project site that must be relocated or demolished to make way for new infrastructure. The ECO-CENTER building will be demolished; other buildings will be repurposed and thus the companies/services affected will be relocated.

Lamothe is currently using one of the historical Quemont administration buildings as their office building. Their aggregate crushing facilities and asphalt plant are currently located on the future process plant site. As part of the Horne 5 Project, Falco intends to relocate Lamothe's infrastructure (offices and crushing facilities) to a lot on Saguenay Boulevard, next to their quarry, where an existing building will be renovated for Lamothe's use. No agreement has been negotiated or entered into with Lamothe as of the effective date of the FS.

The *Centre de Formation Professionnelle Polymétier (Quémont)* (“Centre Polymétier”) is currently using the historical Quémont building as an adult education and professional development school. As part of the Horne 5 Project, Falco will build an extension to the Centre Polymétier located on the site of La Source Secondary School, and the institutional activities will be permanently relocated to this new location. Falco has signed a Memorandum of Understanding with the Commission Scolaire de Rouyn-Noranda to own the existing building that bears the name Pavillon Quémont upon delivery of the relocation project. Construction began on the school relocation in September 2017.

As a result of the extension to La Source Secondary School, the existing soccer field must be relocated. As per the City of Rouyn-Noranda’s request, it will be relocated to parc St-Luc, which is located in the Noranda-North neighborhood.

### 1.12.3 Water Treatment

Water treatment will be required at both the Horne 5 Mining Complex and the TMF site. A prime component of the water treatment systems is the treatment of excess water during preproduction, during which the flooded historical mine workings will be dewatered. Water treatment will continue through the production phase to ensure that the required discharge conditions are met.

Water treatment will consist of metals, sulphate and polythionate removal as well as pH adjustment for all phases of the Horne 5 Project, combined with residual cyanide removal, once production begins at the process plant. Ammonia treatment by pH adjustment is anticipated to be required for a portion of the preproduction period. The metals and sulphate treatment systems will produce by-product HDS, which will then be stored in historical mine workings during preproduction and suitable for management with tailings during production.

A temporary WTP with a 600 m<sup>3</sup>/hr capacity will be built to treat water from the historical mines during the preproduction phase. Treated water from the treatment plant will be discharged into the Dallaire watercourse. As the mine enters the production phase, the temporary WTP will be shut down and the equipment will be dismantled and repurposed to be used as part of the process plant’s cyanide destruction, concentrate and tailings dewatering as well as lime storage circuits.

#### 1.12.4 Tailings Management Facility

The TMF is located at an existing tailings facility (Historic Norbec Mine area) located approximately 11 km northwest of the Horne 5 Mining Complex site and will draw the required power from existing power lines. The estimated power load of the TMF is approximately 1.5 MW.

The PFT and the PCT will be transported separately from the Horne 5 Mining Complex to the TMF. The pipelines will be installed mostly above ground, with underground segments built through open and cut construction or horizontal directional drilling (“HDD”) for river, wetland and road crossings.

The PFT pipeline includes a 17.4 km segment of 10-inch pipe between the process plant and the TMF as well as a 4.8 km segment of 12-inch HDPE pipe around the TMF. The PCT pipeline includes a 17.4 km segment of 12-inch carbon steel pipe between the process plant and the TMF as well as a 2.7 km segment of 12-inch HDPE pipe around the TMF. The transport section of both pipelines will be lined with HDPE as a mitigation measure for potential corrosion and will be thermally insulated.

The TMF will consist of two separate cells, the PCT and PFT cells, as well as two water ponds, the internal pond and the polishing pond.

Construction of the TMF is proposed to occur in five stages with each stage lasting approximately two to four operating years. Four external dikes consisting of a granular fill, complete with upstream inclined low permeability element dikes, will be required to confine the two cells and the polishing pond during the first four stages of operation. The low permeability element will include a bituminous liner system comprised of the membrane itself laid on top of an appropriate transition layer and covered by a granular protection layer.

For the final stage (Stage 5), two additional dikes with similar cross-sections will be required for the PFT cell as well as a new, smaller lined polishing pond. A permanent pumping system will be installed at the PCT cell side for pumping bleed water from the PCT during operation and at closure. Surface water infrastructures will also be built at the TMF site to adequately collect or divert runoff water from this area; the aim will be to maximize the reuse of water, while limiting as much as feasible the ingress of “non-impacted” runoff from undisturbed areas.

A reclaim water pipeline will follow the same route as the tailings pipelines, but will flow in the opposite direction. The reclaim water pipeline will be approximately 19.4 km in length and will be installed above ground, directly on the ground with underground crossings. The pipeline will be assembled from 19,400 m of 20-inch HDPE and will be thermally insulated.

## 1.13 Environmental and Permitting

### 1.13.1 Studies and Permitting

Environmental baseline studies have been initiated in 2016 and are continuing throughout 2017 to support the Environmental Impact Assessment (“EIA”) and permitting process in accordance with the Horne 5 Project timeline.

Consultation and information activities have been on-going and will continue until project completion.

The Horne 5 Project will require a provincial and federal decree. It is subject to a provincial impact assessment study, including public hearings to be held by the *Bureau des audiences publiques du Québec* (“BAPE”), because forecasted production is over the 2,000 tpd threshold outlined in the applicable regulation. The Horne 5 Project will also be subject to a federal impact assessment study.

A project notification and description was submitted to both provincial and federal authorities in 2016 as the first step of the environmental assessment process, however, an updated version will have to be resubmitted to support the addition of a TMF and pipelines.

A certificate of authorization (“CoA”) under Sections 22 and 31.75 of the Environmental Quality Act was issued by the *Ministère du Développement durable, de l’Environnement et de la lutte contre les changements climatiques* (“MDDELCC”) in 2016 for the dewatering of the two first levels of the Quemont No. 2 shaft. However, a new application for a CoA was submitted in July 2017 to support Falco’s revised dewatering and sludge management strategy.

A number of approvals, permits and authorizations will be required in addition to the provincial and federal decrees prior to and during project execution.

### 1.13.2 Waste and Water Management

During preproduction and the initial years of operation, mine waste and water that will not have been pumped and treated for discharge will be managed underground; HDS from the WTP and unused tailings for the production of paste backfill will be stored in mine openings at the historical Donalda, Quemont and Horne mines. The estimated historical underground openings capacity, together with the use of paste backfill, will accommodate about two years of tailings production; the remainder will be stored at the TMF. Paste backfill will continue to require tailings and will be used throughout the entire life of the mine.

Approximately 1.5 Mt of waste rock that will not be used for underground mining operations, e.g. barricades, drains, etc., will be hoisted to the surface and used as construction material at the TMF and managed to control acid rock drainage.

### 1.13.3 Project Closure

In accordance with the Mining Act of Québec, closure and restoration requirements have been developed to return the Horne 5 Project site to an acceptable condition, ensuring that the site is safe and the surrounding environment is protected. The closure cost estimate for the Horne 5 Project is based on dismantling the mine's buildings at the Horne 5 Mining Complex and the restoration of the TMF. Falco intends to dismantle all buildings that will have served its mining operations. Given the proximity of the site to the city, some buildings could be reused or modified for other purposes.

The cost of restoring the Horne 5 Mining Complex and the TMF site is estimated to be \$87.2M. As required by the *Ministère des Ressources Naturelles* ("MERN"), this cost estimate includes the cost of site restoration, the post-closure monitoring as well as engineering costs (30%) and a contingency of 15%. In accordance with the regulations, Falco intends to post a bond as a guarantee against the site restoration cost.

## 1.14 Market Studies and Contracts

### 1.14.1 Metal Pricing

The long term prices for gold, silver, copper and zinc were estimated on the basis of discussions with experts, consensus analyst estimates and recently-published economic studies that were deemed to be credible. The forecasts used are meant to reflect the average metal price expectation over the life of the Horne 5 Project. The base case gold, silver, copper and zinc prices used for the economic analysis are 1,300 USD/oz, 19.50 USD/oz, 3.00 USD/lb, and 1.10 USD/lb, respectively.

### 1.14.2 Concentrate Logistics

The Horne 5 concentrates will be delivered either directly to a smelter in North America via truck and/or rail, or by ocean going vessel to an offshore smelter, likely situated in Europe.

Estimated logistics costs for the movement of the concentrates to various destinations, including rail, stevedoring/port costs and ocean rates were obtained from select service providers. Other costs, e.g. insurance, third party supervision, etc., are based on typical market rates. The freight and allowances value used for the zinc concentrate is 89.26 \$/t and 93.40 \$/t for the copper concentrate.

### 1.14.3 NSR Calculations

The commercial terms, which include payable metal quantities, treatment charges, refining charges and penalties, where applicable, are based on long-term charges as projected by Exen Consulting, which are expected to apply to products with similar characteristics to the Horne 5 copper and zinc concentrates and gold doré. The terms used in derivation of the NSR for the copper and zinc concentrate and gold doré are summarized in Chapter 19.

### 1.14.4 Contracts

Glencore Canada retains a 2% net smelter return royalty on all metals produced and has rights of first refusal with respect to purchase or toll process all or any portion of the concentrates and other mineral products. There are currently no contracts in place regarding the sales of concentrates from the Horne 5 Project. However, as of the effective date of this Report, Falco has awarded a number of equipment and service contracts as part of the pre-construction activities of the Horne 5 Project. These contracts pertain to the overall engineering, procurement, supply, performance services and installation of the mine hoisting system, mine hoist room and headframe engineering, mine dewatering engineering and the purchase of major water treatment equipment.

Glencore Canada has rights of first refusal with respect to purchase or toll process all or any portion of the concentrates and other mineral products from the Horne 5 Project.

## 1.15 Capital Cost Estimate

The total capital cost of the Horne 5 Project, including preproduction and sustaining costs, is estimated at \$1.597B. The preproduction costs were calculated at \$1.062B, including a \$75.0M contingency. The sustaining costs, excluding site rehabilitation costs, were calculated at \$535M. Sunk costs of \$34.3M have been committed to date.

The overall capital cost estimate developed in this Study meets the AACE International (“AACE”) class 3 estimate requirements and has an accuracy range of -10% and +15%. The capital cost estimate was compiled using a combination of quotations (budgetary and fixed price), database costs, and database factors. Items such as sales taxes, certain land acquisition, permitting, licensing, price escalation, feasibility studies and financing costs are not included in the cost estimate. The Horne 5 Project capital cost summary is outlined in Table 1-6 and in Figure 1-5.

Table 1-6: Project capital costs (preproduction and sustaining)

WBS	Cost Area	Preproduction Capital Cost (\$M)	Sustaining Capital Cost (\$M)	Total Cost (\$M)
000	General Administration	47.2		47.2
200	Underground Mine	256.9	325.1	582.0
300	Mine Surface Facilities	81.8	4.7	86.5
400	Electrical & Communication	18.3	2.3	20.5
500	Site Infrastructure	13.2	-	13.2
600	Process Plant	379.4	13.0	392.5
700	Community Infrastructure and Relocation	36.1	-	36.1
800	Tailings and Water Management	68.5	190.3	258.7
900	Indirects	85.8	-	85.8
999	Contingency	75.0	-	75.0
	<b>Total</b>	<b>1,062.1</b>	<b>535.4</b>	<b>1,597.5</b>
	Less Outlays to August 31, 2017	(34.3)	-	(34.3)
	Site Reclamation and Closure	-	87.2	87.2
	Salvage Value	-	(45.0)	(45.0)
	<b>Total – Forecast to Spend</b>	<b>1,027.8</b>	<b>577.5</b>	<b>1,605.4</b>

<sup>(1)</sup> Sustaining costs include indirects and contingency



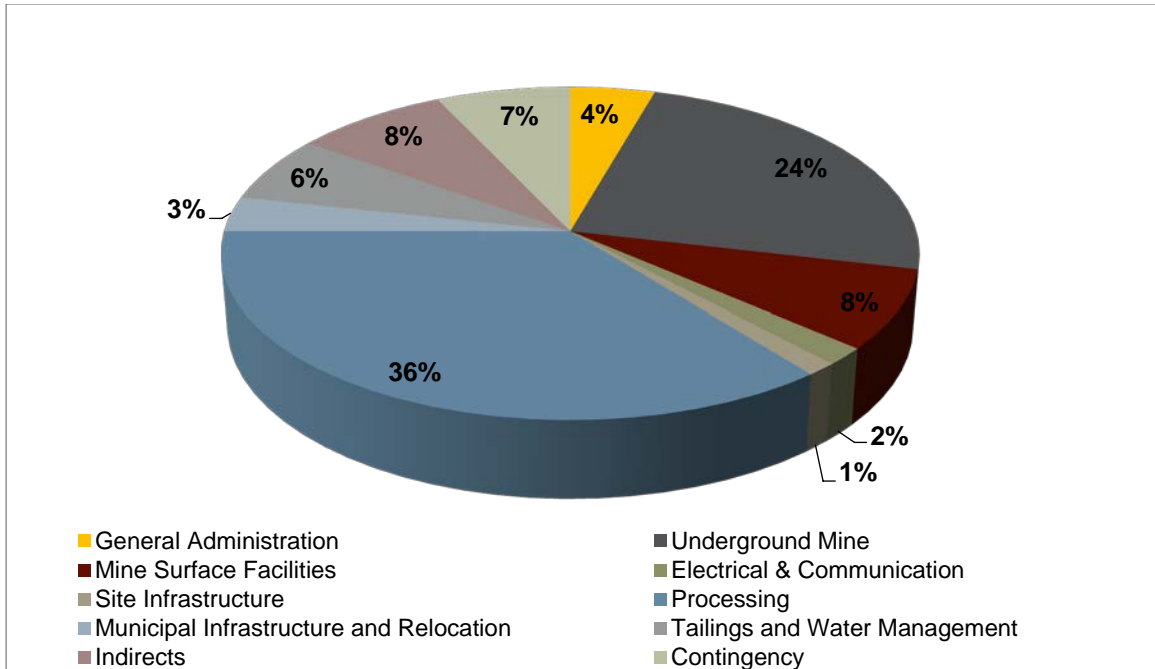

Figure 1-5: Capital cost summary (preproduction)

All capital costs for the Project have been distributed against the development schedule to support the economic cash flow model. Figure 1-6 presents the planned annual and cumulative LOM capital cost profile.

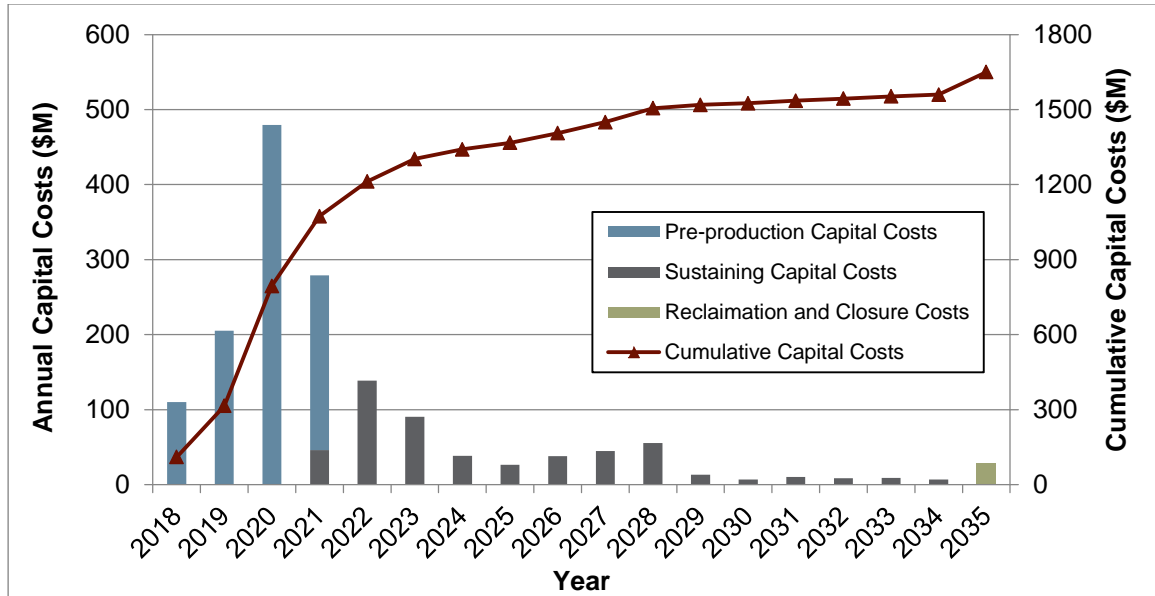

Figure 1-6: Overall capital cost profile

### 1.16 Operating Cost Estimate

The operating cost estimate (“OPEX”) is based on a combination of experience, reference project, budgetary quotes and factors as appropriate with a feasibility study. The target accuracy of the operating cost is +/-10%. No cost escalation or contingency has been included within the operating cost estimate.

The operating cost estimate in this FS includes the costs to mine, process the mineralized material to produce copper and zinc concentrates, gold doré, and tailings as well water treatment and general and administration expenses (“G&A”).

The average operating cost over the LOM is estimated to be 41.00 \$/t milled. Total LOM and unit operating cost estimates are summarized in Table 1-7 and shown as a pie chart by percentage in Figure 1-7.

Table 1-7: Project operating costs

Cost Area	LOM Total (\$M)	Average (\$M/year)	Average (\$/tonne)	OPEX (%)
Mining	1,020	68	12.60	31
Processing	1,654	110	20.45	50
Tailings, Water Treatment and Environment	411	27	5.08	12
General and Administration	231	15	2.86	7
<b>Total</b>	<b>3,316</b>	<b>221</b>	<b>41.00</b>	<b>100</b>

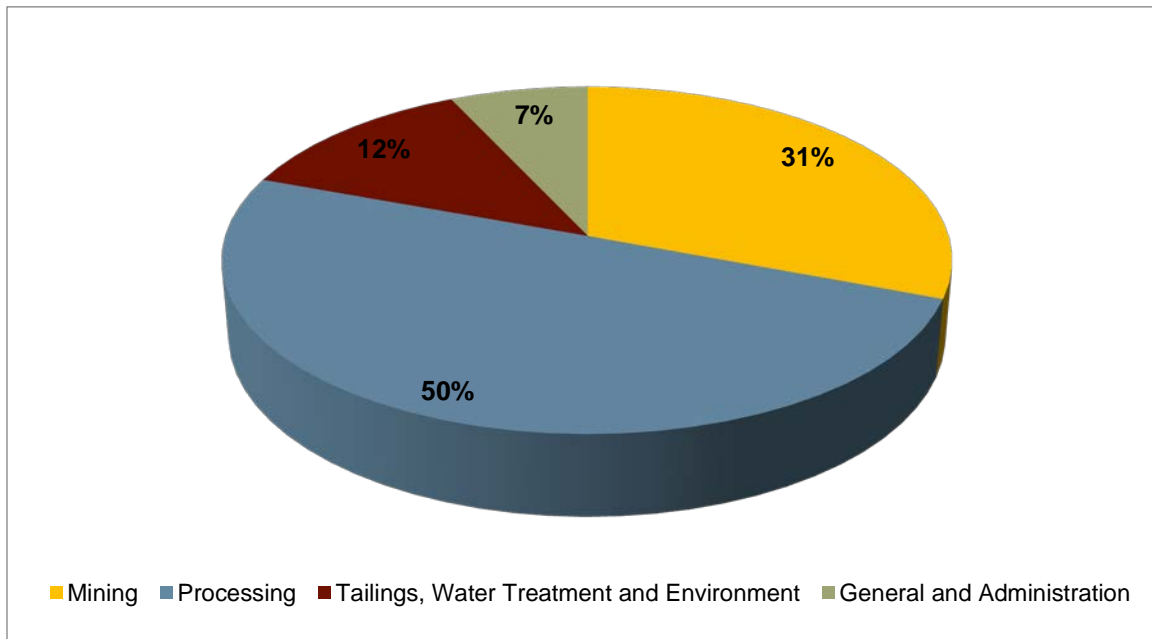

Figure 1-7: Operating cost summary (by area)

It is anticipated that 496 employees (staff and labour) will be required for operations during the period without a surface TMF. Once the TMF is in place (2023), the number of employees required is expected to increase to approximately 502. Table 1-8 provides a summary of the employees by facility.

Table 1-8: Employee summary – all areas

Facility Area	Number
Underground Mine <sup>(2)</sup>	325
Process Plant (Including Paste Plant)	93
Tailings, Water Treatment and Environment <sup>(1)</sup>	22
General and Administration	62
<b>Total – Horne 5 Mining Complex</b>	<b>502</b>

<sup>(1)</sup> Total includes employees required by the surface TMF once operations begin at the facility.

<sup>(2)</sup> Total does not include employees for underground tailings service prior to the surface TMF operations.

## 1.17 Project Economics

The economic/financial assessment of the Horne 5 Project was carried out using a discounted cash flow approach on a pre-tax and after-tax basis, based on Q2-2017 metal price projections in U.S. currency and cost estimates (CAPEX and OPEX) in Canadian currency. Inflation or cost escalation factors were not taken into account. An exchange rate of 0.78 USD for 1.00 CAD has been assumed over the life of the Horne 5 Project. The base case gold, silver, copper and zinc prices are 1,300 USD/oz., 19.50 USD/oz., 3.00 USD/lb and 1.10 USD/lb, respectively. The input parameters used and results of the financial analysis are presented in Table 1-9.

Over the life of mine, a total of 3.294 Moz of gold (Payable) (Average annual: approximately 219,000 oz) will be produced. Figure 1-8 provides a summary of the payable gold production by year.

The pre-tax base case financial model resulted in an internal rate of return (“IRR”) of 18.9% and a net present value (“NPV”) of \$1,297 using a 5% discount rate. The pre-tax payback period is 5.2 years.

On an after-tax basis, the base case financial model resulted in an IRR of 15.3% and a NPV of \$772 using a 5% discount rate. The after-tax payback period is 5.6 years.

The all-in sustaining costs over the LOM are 399 USD/oz net of by-product credits, including royalties, which generates an operating margin of 901 USD/oz.

Table 1-9: Financial analysis summary

Description	Unit	Value
Total material mined	tonnes	80,896,876
Average Diluted Gold Equivalent Grade	g/t AuEq	2.37
Average Diluted Gold Grade	g/t Au	1.44
Total Gold Contained	oz	3,740,871
Total Gold Produced	oz	3,338,965
Total Gold Payable	oz	3,294,197
Total Silver Payable	oz	26,289,869
Total Copper Payable	million lbs	229
Total Zinc Payable	million lbs	1,007
Average Annual Gold Production	Au oz per year	222,598
Average Annual Payable Gold Production	Au oz per year	219,462
Preproduction Capital Cost (less outlays as of August 31, 2017)	\$M	1,028
Sustaining Capital	\$M	535
Site Restoration Cost	\$M	87.2
Salvage Value	\$M	45
Overall Operating Cost	\$ per tonne (\$/t) milled	41.00
All-in Sustaining Costs ("AISC")	USD/oz	399
LOM Royalties (2% NSR)	\$M	157
Total LOM Pre-Tax Cash Flow	\$M	2,772
LOM Taxes (Income and Mining)	\$M	1,006
Total LOM After-Tax Free Cash Flow	\$M	1,766
Average Annual After-Tax Free Cash Flow	\$M	187
<b>Pre-Tax Summary</b>		
Pre-Tax NPV (@ 5% Discount Rate)	\$M	1,297
Pre-Tax IRR	%	18.9
Pre-Tax Payback	years	5.2
<b>After-Tax Summary</b>		
After-Tax NPV (@ 5% Discount Rate)	\$M	772
After-Tax IRR	%	15.3
After-Tax Payback	years	5.6

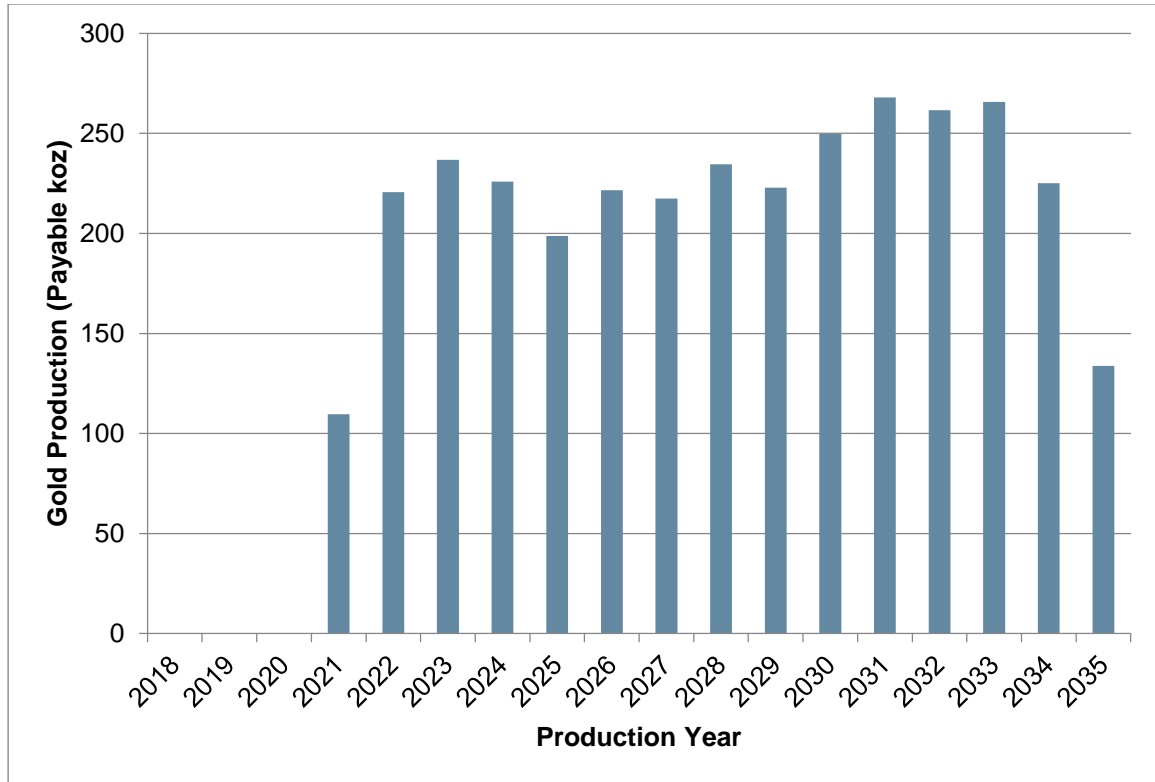

Figure 1-8: Annual Payable Gold Production (koz)

A financial sensitivity analysis was conducted on the Horne 5 Project’s after tax NPV and IRR using the following variables: capital cost, including preproduction and sustaining, operating costs, USD:CAD exchange rate, and the price of gold.

The graphical representations of the financial sensitivity analysis on NPV and IRR are depicted in Figure 1-9 and Figure 1-10. The sensitivity analysis reveals that the USD:CAD exchange rate has the most significant influence on both NPV and IRR compared to the other parameters, based on the range of values evaluated. After the USD:CAD exchange rates, NPV was most impacted by changes in the gold price and then to a lesser but equal extent by variations in operating costs and capital costs. It should be noted that the economic viability of the Project will not be significantly negatively impacted by variations in the capital cost, within the margins of error associated with the FS capital cost estimate.

After the USD:CAD exchange rates, the Horne 5 Project’s IRR was most impacted by variations in the capital cost and to a lesser extent by variations in gold price, followed by the operating costs.

Overall, the NPV and IRR of the Horne 5 Project are positive over the range of values used for the sensitivity analysis.

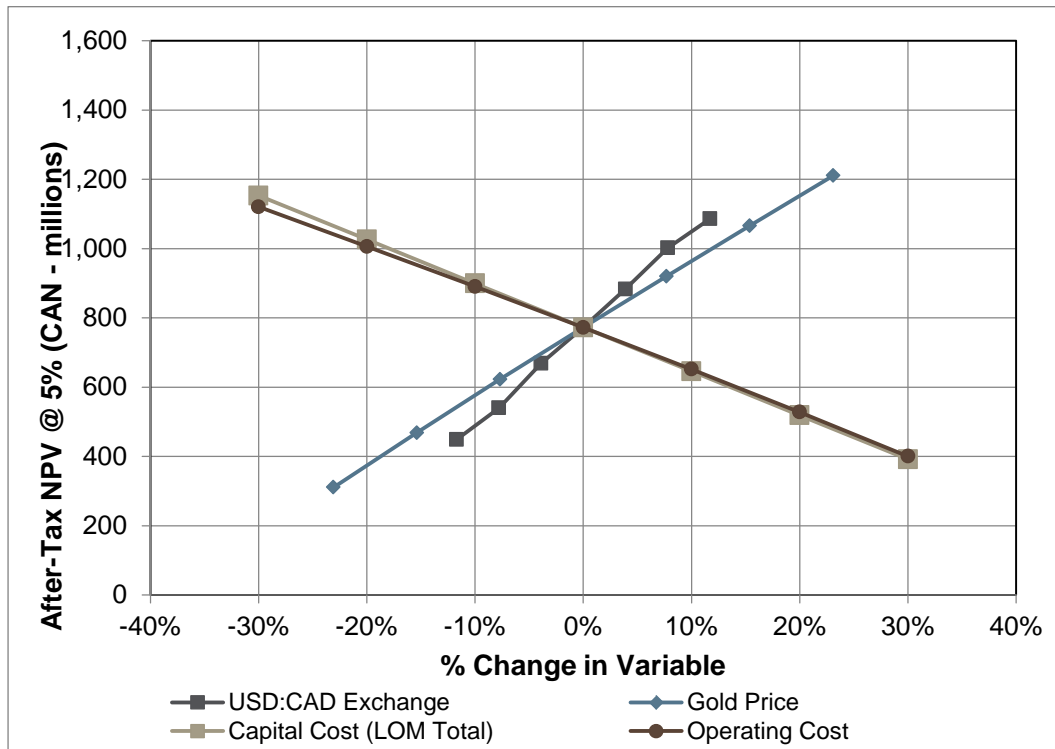

Figure 1-9: Net present value (5% discount rate, after-tax) sensitivity analysis

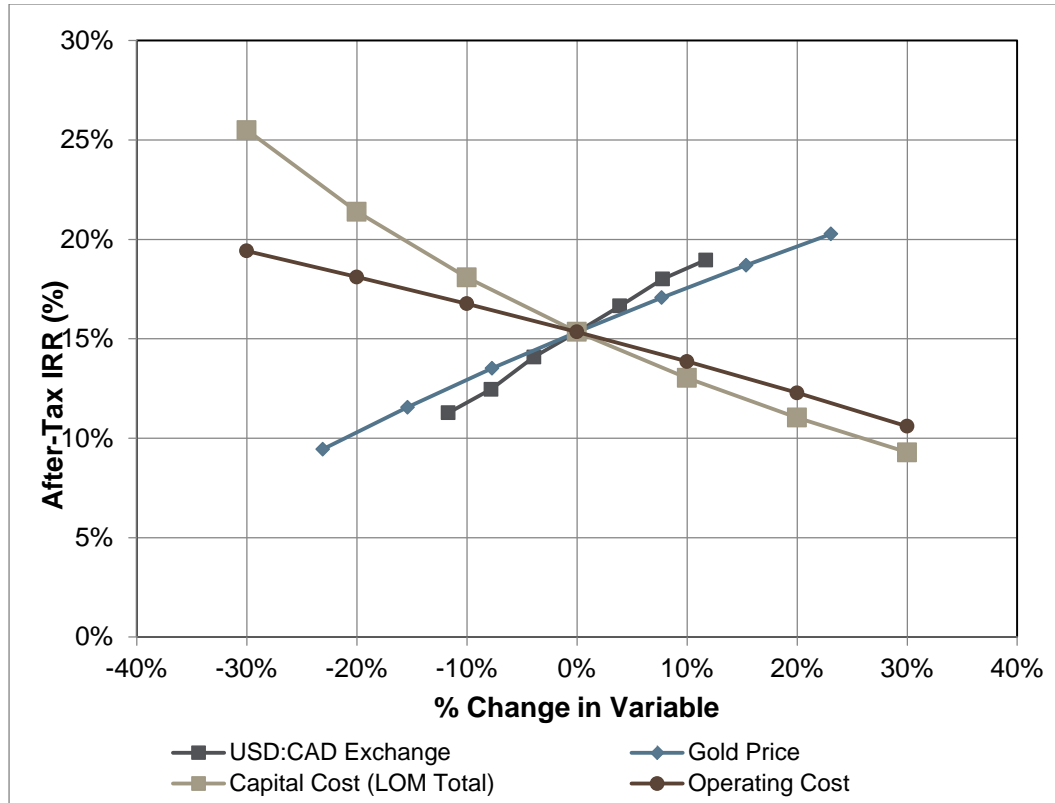

Figure 1-10: Internal rate of return (after-tax) sensitivity analysis

### 1.18 Project Organization and Schedule

The execution of the Horne 5 Project will be directly managed by the Falco project management team. The engineering and construction works will be contracted out to qualified firms and contractors under the direct supervision of Falco. Procurement and project control functions such as scheduling, cost control, project logistics and site supervision will be executed directly by Falco personnel.

Contractors will carry out all project development activities, including rehabilitation and dewatering of the various historic underground mines, developing and installing the underground fixed infrastructure, water treatment plants, conveyor systems and process plant equipment as well as renovating the existing site buildings and constructing the planned surface TMF. The preliminary on-site workforce requirement for construction, including infrastructure, process plant, and development of the underground mine is expected to peak at approximately 950 individuals.



The major project activity milestones are presented in Table 1-10. Pending the completion of all studies and receipt of the required permits, the process plant construction is scheduled to begin in mid-2019 with full capacity production beginning in H2 2021.

**Table 1-10: Key project activities (preliminary)**

Activity	Start Date	Completion Date
Feasibility Study		Completed
Environmental Impact Assessment (EIA)	Q2 2016	Q4 2017
Detailed Engineering	Q4 2017	Q2 2020
Mine Dewatering	Q2 2018	Q2 2020
Head Frame & Hoist Room Construction (Mine Dewatering and Rehabilitation Phase)	Q4 2017	Q3 2018
Quemont No. 2 Shaft Rehabilitation	Q2 2018	Q4 2019
Public Audiences – “BAPE”	Q4 2018	Q1 2019
Permit for Project Construction		Q2 2019
Process Plant Construction	Mid-2019	Q1 2021
Preproduction Mine Development	Q3 2019	Q2 2021
First Mineralized Material from Mine		Q2 2021
Production achieved in Mine (Phase 1)		Q3 2021
Process Plant Commissioning	Q2 2021	Q2 2021
Process Plant Ramp-Up		H2 2021
Full Mine Production (Phase 1)		H1 2022
Surface TMF Operations	Q2 2023	
Quemont No. 2 Shaft Deepening	Q1 2027	Q2 2028
Production Achieved in Mine (Phase 2)	Q3 2028	

Once in production, there will be several significant periods of construction during the mine life. Construction of the planned TMF will begin in Q2 2022 to be operational for Q2 2023. Tailings and reclaim pipelines, polishing pond and reclaim pump house construction will also begin in Q2 2022 for completion at the same time as the TMF.

Quemont No. 2 shaft re-sinking will occur in 2027 and 2028, allowing for first mineralized material production from Phase 2 in the second half of 2028.

## 1.19 Interpretations and Conclusions

This Study was prepared by a group of independent consultants to demonstrate the economic viability of an underground mine and process plant complex targeting all mineral resources defined in the Horne 5 Project. This Report provides a summary of the results and findings from each major area of investigation. Standard industry practices, equipment and processes were used in this Study. To date the QPs are not aware of any unusual or significant risks or uncertainties that could materially affect the reliability or confidence in the Horne 5 Project based on the information available.

The results of the Study indicate that the proposed Project has technical and financial merit using the base case assumptions. The results are considered sufficiently reliable to guide Falco's management in a decision to advance to the next stage of development: that being mainly the start of the dewatering program, detailed engineering, project financing and permitting.

### 1.19.1 Risks and Opportunities

An analysis of the results of the investigations has identified a series of risks and opportunities associated with each of the technical aspects considered for the development of the Horne 5 Project.

The most significant potential risks associated with the Project are:

- Ability of Falco to obtain third party approvals, licenses, rights of way and surface rights in a timely manner and on terms acceptable to the company;
- Mine dewatering volume could be greater or lower, and water quality could be better or worse than estimated;
- Condition of historical mine openings and infrastructure could be worse than anticipated;
- The actual rock mass behaviour could differ from expected and influence stope dimensions, pillar recovery, ground support, mining and development sequences, as well as dilution and recovery. These could negatively affect the Project economics;
- Inability to achieve production targets with new technologies;
- Uncertainties with respect to the underground volumes available for tailings storage. Underestimation of available storage space would result in the surface TMF being required at an earlier stage of the Project;
- Commodity price and exchange rate fluctuations.

Many of the previous noted risks are common to most mining projects, many of which may be mitigated, at least to some degree, with adequate engineering, planning and pro-active management.

There are a number of opportunities that could improve the economics, timing and/or permitting potential of the Project.

The key opportunities that have been identified at this time are as follows:

- There is significant exploration potential for discoveries at depth and around the Horne 5 Project. Historical work did not focus on gold. The possibility exists to increase resources and extend mine life;
- Further definition drilling may convert some of the existing Inferred mineral resources to the Indicated or Measured resource categories;
- Investigating the potential to transfer larger quantities of tailings to the historical UG mines, thus lowering the volume sent to the TMF, may lead to reduced OPEX and CAPEX;
- An improved conceptual TMF design and tailings pipeline routing through additional geotechnical and engineering studies could potentially reduce CAPEX;
- The leach-CIP circuits in the process plant could be replaced by CIL circuits. A trade-off study is recommended to select the circuit that has the best overall economics. Potential CAPEX and OPEX savings as well as increased gold recoveries may be realized;
- Application of pre-assembled steel structures, pre-cast foundations and pre-fabricated buildings could reduce capital costs and shorten the on-site construction period.

## 1.20 Recommendations

The qualified persons recommend that the Project proceed to the detailed engineering phase and that project execution activities commence at Falco's discretion. Important activities that need to be initiated or completed to maintain the proposed execution schedule are as follows:

- Complete negotiations in a timely manner to obtain third party approvals, licenses, rights of way and surface rights required by the project as described in this FS;
- The environmental work, community engagement and permitting should continue as needed to support Falco's development plans;
- The relocation program should be initiated for the buildings located on the Horne 5 Mining Complex site;
- The preproduction dewatering program of the historical mines surrounding the Horne 5 deposit;
- The EIA should be completed and submitted;
- The early works program should be initiated and detailed engineering completed for the headframe and hoist room;
- Secure financing.

A budget of \$110M has been established for project related activities and equipment purchases in 2018.

## 2. INTRODUCTION

This Report was prepared and compiled by BBA at the request of Falco. The purpose of the Report is to summarize the results of the FS for the Horne 5 deposit on the Concession in accordance with the guidelines of the Canadian Securities Administrators National Instrument 43-101 and Form 43-101F1.

BBA is an independent engineering consulting firm headquartered in Montreal, Québec. This report was prepared with contributions from InnovExplo, Golder, WSP, SNC-Lavalin and RIVVAL.

The Property, which has also been called the “Rouyn-Noranda Project” by Falco, is located in the Abitibi region of central-northwest Québec, Canada. It covers an area approximately 30 km by 65 km in the townships of Hébécourt, Duparquet, Destor, Montbray, Duprat, Dufresnoy, Cléricy, La Pause, Dasserat, Beauchastel, Rouyn and Joannes. The Horne 5 deposit is located within the urban limits of the city of Rouyn-Noranda in Rouyn Township, NTS map sheets 32D-03 and 32D-06. The Horne 5 deposit sits immediately next to the former producing Horne mine that was operated by Noranda Inc. from 1926 to 1976, producing approximately 2.5 billion pounds of copper and 11.6 million ounces of gold.

### 2.1 Falco Resources Ltd.

Falco was initially founded as Druk Capital Partners Inc. (“Druk”), which was incorporated on March 16, 2010, in British Columbia by Certificate of Incorporation pursuant to the provisions of the province’s Business Corporations Act. Druk was a Capital Pool Company (“CPC”) as defined in Policy 2.4 of the TSX Venture Exchange (“TSXV”). As a CPC, Druk’s principal business was to identify, evaluate and acquire assets, properties or businesses that would constitute a qualifying transaction (“QT”) in accordance with Policy 2.4 of the TSXV. On August 10, 2010 Druk filed a prospectus with the securities commissions of British Columbia and Alberta offering 2,000,000 common shares at \$0.10 per share as an initial public offering (“IPO”). The IPO was completed on August 30, 2010.

Subsequent to the year ended June 30, 2012, Druk completed its QT by acquiring 100% of QMX Gold Corporation’s (“QMX”) rights, titles and interest in the Rouyn-Noranda base-precious metal camp in Québec, Canada. To complete the QT, Druk paid QMX \$5,000,000 and issued 7,000,000 shares. Upon completion of the QT, Druk’s principal business became the exploration and evaluation of these mineral properties to determine whether or not the properties contain economically recoverable mineral reserves. Druk also announced on September 14, 2012, that on the closing of the transaction, it would change its name to Falco Pacific Resource Group Inc. and would commence trading on the TSXV as a Tier 2 Mining Issuer under the trading symbol “FPC”.

On July 24, 2014, Falco Pacific Resource Group Inc. changed its name to Falco Resources Ltd. On June 15, 2015, Falco was continued under the *Canada Business Corporations Act*.

## 2.2 Basis of Technical Report

The following Report presents the results of the FS for the development of the Horne 5 Project. Falco mandated engineering consulting group BBA to lead and perform the FS, based on contributions from a number of independent consulting firms including InnovExplo, Golder, SNC-Lavalin, WSP and RIVVAL. This Report was prepared at the request of Mr. Luc Lessard, President and CEO of Falco Resources Ltd. As of the date of this Report, Falco Resources Ltd. is a Canadian exploration and development company trading on the TSXV under the trading symbol (“FPC”), with its head office situated at:

1100, avenue des Canadiens-de-Montréal  
 Suite 300  
 Montréal, Québec  
 H3B 2S2

This Report, titled “Feasibility Study of the Horne 5 Gold Project”, was prepared by Qualified Persons (“QPs”) following the guidelines of the NI 43-101 and in conformity with the guidelines of the Canadian Institute of Mining, Metallurgy and Petroleum (“CIM”) Standards on Mineral Resources and Reserves.

A summary of the Report contributors and their general areas of responsibility are presented in Table 2-1.

Table 2-1: Major study contributors

Consulting Firm or Entity	Area of Responsibility
BBA	<ul style="list-style-type: none"> <li>▪ Metallurgical testwork analysis, processing plant design;</li> <li>▪ Process plant capital costs and operating costs;</li> <li>▪ Electrical and IT infrastructure design and costs (supply and on-site);</li> <li>▪ Market studies and contracts;</li> <li>▪ General and administration operating costs;</li> <li>▪ Financial Analysis and overall NI 43-101 integration.</li> </ul>
InnovExplo	<ul style="list-style-type: none"> <li>▪ Current and historical geology, exploration, drilling, sample preparation and QA/QC, and data verification;</li> <li>▪ Geological modelling and mineral resource estimate;</li> <li>▪ Mineral reserves estimate;</li> <li>▪ Underground mine design, underground infrastructure and material handling, ventilation, production scheduling, underground capital costs and operating costs, void evaluation;</li> <li>▪ Historical data review.</li> </ul>

Consulting Firm or Entity	Area of Responsibility
Golder	<ul style="list-style-type: none"> <li>▪ Waste rock, tailings, mineralization and water geochemical characterization;</li> <li>▪ Water treatment plant design, capital and operating costs;</li> <li>▪ Underground high density sludge, slurry and paste backfill and slurry tailings distribution systems design and costs;</li> <li>▪ Surface tailings and waste rock management facility and water management designs and costs, including closure costs;</li> <li>▪ Surface tailings, reclaim and fresh water transport system design and costs;</li> <li>▪ Mine site water management infrastructure design and costs;</li> <li>▪ Rock mass characterization and rock mechanics input to underground mine design and ground control;</li> <li>▪ Hydrogeology input to underground mine design;</li> <li>▪ Geotechnical input for the surface infrastructure design.</li> </ul>
WSP	<ul style="list-style-type: none"> <li>▪ Environmental studies, permitting, mine closure requirements and Horne 5 Mining Complex closure costs;</li> <li>▪ Regulatory context, social considerations, and anticipated environmental issues;</li> <li>▪ Headframe and hoist room design and costs;</li> <li>▪ Shaft design and associated underground work and costs;</li> <li>▪ Ore handling system from underground mine (Phase 1) to surface stockpile, design and costs;</li> <li>▪ Paste backfill plant design, capital and operating costs.</li> </ul>
SNC-Lavalin	<ul style="list-style-type: none"> <li>▪ Existing infrastructure, municipal infrastructure and relocation, design and costs;</li> <li>▪ Site access road, security gate and light vehicle road design and costs;</li> <li>▪ First-aid and emergency services, costs;</li> <li>▪ Site utilities design and costs.</li> </ul>
RIVVAL	<ul style="list-style-type: none"> <li>▪ Railway engineering design and costing.</li> </ul>

Each QP is responsible for various sections of this Report, according to his or her expertise and scope of work. A list of the QPs is presented in the next section.

## 2.3 Report Responsibility and Qualified Persons

The following individuals, by virtue of their education, experience and professional association, are considered QPs as defined in the NI 43-101, and are members in good standing of appropriate professional institutions.

▪ Colin Hardie, P.Eng.	BBA Inc.
▪ Pierre Lacombe, P.Eng.	BBA Inc. (Now with Lundin Mining Corp.)
▪ Carl Pelletier, P.Geo.	InnovExplo Inc.
▪ Patrick Frenette, P.Eng.	InnovExplo Inc.
▪ Geneviève Auger, P.Eng.	InnovExplo Inc.
▪ Michel Mailloux, P.Eng.	Golder Associates Ltd.
▪ Valerie Bertrand, P.Geo.	Golder Associates Ltd.
▪ Mayana Kissiova, P.Eng.	Golder Associates Ltd.
▪ Rob Bewick, P.Eng.	Golder Associates Ltd.
▪ Michael Bratty, P.Eng.	Golder Associates Ltd.
▪ Yves Boulianne, P.Eng.	Golder Associates Ltd.
▪ Janis Drozdiak, P.Eng.	Golder Associates Ltd.
▪ Serge Ouellet, P.Eng.	Golder Associates Ltd.
▪ Marie-Claude Dion St-Pierre, P.Eng.	WSP Canada Inc.
▪ Stéphane Lance, P.Eng.	WSP Canada Inc.
▪ Claire Hayek Eng., MBA	WSP Canada Inc.
▪ Dominick Turgeon, P. Eng.	WSP Canada Inc.
▪ Luc Gaulin Eng, MBA	SNC-Lavalin Stavibel Inc.
▪ Yves Vallières, P.Eng.	Ingénierie RIVVAL Inc.

The preceding QPs have contributed to the writing of this Report and have provided QP certificates, included at the beginning of this Report. The information contained in the certificates outlines the sections in this Report for which each QP is responsible. Each QP has also contributed figures, tables and portions of Chapters 1 (Summary), 25 (Interpretation and Conclusions), and 26 (Recommendations). Table 2-2 outlines the responsibilities for the various sections of the Report and the name of the corresponding Qualified Person.

Table 2-2: Qualified Persons and areas of report responsibility

Chapter	Description	Company Responsible	Qualified Person	Comments and Exceptions
1.	Executive Summary	BBA	C. Hardie	All QPs contributed based on their respective scope of work and the chapters/sections under their responsibility.
2.	Introduction	BBA	C. Hardie	All Sections
3.	Reliance on other Experts	BBA	C. Hardie	All QPs contributed based on their respective scope of work and the chapters/sections under their responsibility.
4.	Project Property Description and Location	InnovExplo	C. Pelletier	All Sections
5.	Accessibility, Climate, Local Resource, Infrastructure and Physiography	InnovExplo	C. Pelletier	All Sections
6.	History	InnovExplo	C. Pelletier	All Sections
7.	Geological Setting and Mineralization	InnovExplo	C. Pelletier	All Sections
8.	Deposit Types	InnovExplo	C. Pelletier	All Sections
9.	Exploration	InnovExplo	C. Pelletier	All Sections
10.	Drilling	InnovExplo	C. Pelletier	All Sections
11.	Sample Preparation, Analyses and Security	InnovExplo	C. Pelletier	All Sections
12.	Data Verification	InnovExplo	C. Pelletier	All Sections
13.	Mineral Processing and Metallurgical Testing	BBA	P. Lacombe <sup>1</sup>	All sections except (13.8). Testwork performed by independent laboratories. BBA responsible for integration and interpretation of the metallurgical testwork results.
		WSP	C. Hayek	Paste Backfill Filtration Testing (13.8)
14.	Mineral Resource Estimate	InnovExplo	C. Pelletier	October 2017 MRE (Effective July 25, 2017)
15.	Mineral Reserve Estimates	InnovExplo	P. Frenette	All Sections. Reserve Estimate based on November 2016 MRE.
16.	Mining Methods	InnovExplo	G. Auger	Mine dewatering (16.4), Mine services (16.5.1 to 16.5.4), Mine design (16.6.2, 16.6.4,16.6.5), Mining Method (16.7.3), Underground Mine Equipment (16.10), and Mine Personnel (16.11)
			P. Frenette	Introduction (16.1), Mine Services (16.5.5), 16.6 (Introduction), Mine Design (16.6.6), and Mining Method (16.7 except 16.7.3)
		Golder	R. Bewick	Rock Engineering (16.2)
			M. Mailloux	Mine Hydrogeology (16.3)
			S. Ouellet	Cemented Paste Backfill (16.8) and Underground High Density Sludge and Slurry Tailings Disposal (16.9)
WSP	S. Lance	Mine Design (16.6.1, 16.6.3)		



Chapter	Description	Company Responsible	Qualified Person	Comments and Exceptions
17.	Recovery Methods	BBA	P. Lacombe <sup>(1)</sup>	All Sections except 17.2.13
		WSP	C. Hayek	Paste Backfill Circuit (17.2.13)
18.	Project Infrastructure	BBA	C. Hardie	General (18.1), Site Arrangement (18.2), Site Preparation (18.3), Electrical Infrastructure, (18.7), Process Plant (18.9), and Communication and IT (18.15)
		Golder	Y. Boulianne	Geotechnical Studies (18.4)
			M. Kissiova	TMF Infrastructure (18.21), and Surface Water Management (18.22)
			M. Bratty	Water Treatment Infrastructure (18.23)
			J. Drozdziak	Tailings Pipelines (18.24), Reclaim Water Pipeline (18.25), and Fresh Water Infrastructure (18.26)
		InnovExplo	G. Auger	Bulk Explosives Storage and Magazines (18.16), and Fuel Storage and Distribution (18.17)
		WSP	S. Lance	Hoist Room and Headframe (18.8)
		SNC-Lavalin	L. Gaulin	Site Access Road and Control (18.5), Light Vehicle Roads (18.6), Warehouse and Service Building (18.10), Mine Office and Dry Building (18.11), First Aid Emergency Services (18.12) Administration Building (18.13), Site Utilities (18.18), Municipal Infrastructure (18.19), and Site Infrastructure Relocation (18.20)
RIVVAL	Y. Vallières	Railways (18.14)		
19.	Market Studies and Contracts	BBA	C. Hardie	Contribution from Exen Consulting Services
20.	Environmental Studies, Permitting, and Social or Community Impact	Golder	V. Bertrand	Geochemical Assessment (20.2.2), and Water Quality Prediction (20.2.9)
			M. Kissiova	Tailings, Waste Rock and Water Management (20.2.1, 20.2.3 to 20.2.8)
		WSP	M-C. Dion St-Pierre	Environmental studies, permitting (20.1, 20.3 to 20.6)

Chapter	Description	Company Responsible	Qualified Person	Comments and Exceptions
21.	Capital and Operating Costs	BBA	C. Hardie	Responsible for overall Chapter 21 CAPEX, OPEX and manpower integration. Responsible for Sections 21.1.1 to 21.1.3.1.2, 21.1.3.1.5, 21.1.3.2, 21.1.3.3, 21.1.3.10, 21.1.4, 21.1.4.6, 21.2 to 21.2.2.3, 21.2.6, and 21.2.7; Contributor to Sections 21.1.3.1.7, 21.1.3.1.9, 21.1.4.1, 21.1.4.3, and 21.2.5
			P. Lacombe <sup>(1)</sup>	Responsible for Section 21.2.4
		InnovExplo	P. Frenette / G. Auger	Responsible for Section 21.2.3; Contributor to Sections 21.1.3.1.1, 21.1.3.1.3, 21.1.3.1.4 and 21.1.4.1
		WSP	C. Hayek	Contributor to Sections 21.1.3.1.7, and 21.2.5
			M-C. Dion St-Pierre	Contributor to Section 21.1.4.5 (Horne 5 Mining Complex)
			S. Lance	Contributor to Sections 21.1.3.1.3, 21.1.3.1.4, 21.1.4.1, and 21.1.4.2
			D. Turgeon	Contributor to Sections 21.1.3.1.3, and 21.1.4.1
		Golder	J. Drozdiak	Contributor to Sections 21.1.3.1.9, 21.1.4.3, 21.1.4.4, and 21.2.5
			M. Bratty	Contributor to Sections 21.1.3.1.9, 21.1.4.4, and 21.2.5
			M. Kissiova	Contributor to Sections 21.1.3.1.9, 21.1.4.4, and 21.1.4.5 (Surface TMF)
			S. Ouellet	Contributor to Sections 21.1.3.1.3, 21.1.3.1.9, and 21.1.4.1
		SNC-Lavalin	L. Gaulin	Contributor to Sections 21.1.3.1.6, and 21.1.3.1.8
RIVVAL	Y. Vallières	Contributor to Section 21.1.3.1.6		
22.	Economic Analysis	BBA	C. Hardie	Falco provided metal prices, exchange rates and royalty costs. Golder and WSP provided closure costs. Falco calculated project taxes and after-tax cash flows.
23.	Adjacent Properties	InnovExplo	C. Pelletier	All Sections
24.	Other Relevant Data and Information	BBA	C. Hardie	Schedule and execution plan developed by BBA based on inputs from all contributors and Falco.
25.	Interpretation and Conclusions	BBA	C. Hardie	All QPs contributed based on their respective scope of work and the chapters/sections under their responsibility.
26.	Recommendations	BBA	C. Hardie	All QPs contributed based on their respective scope of work and the chapters/sections under their responsibility.
27.	References	BBA	C. Hardie	All QPs contributed based on their respective scope of work and the chapters/sections under their responsibility.

<sup>(1)</sup> As of the effective date of this report, P. Lacombe is now employed by Lundin Mining Corporation.

## 2.4 Effective Dates and Declaration

This Report supports the Falco Resources press release “Falco Announces Positive Feasibility Study on Horne 5 Gold Project” dated October 16, 2017. The overall effective date of the Report is October 5, 2017. The Report has a number of cut-off dates for information:

- Effective date of the Mineral Resource used as the basis of the Mineral Reserves and LOM Plan: September 26, 2016;
- Date of last supply of laboratory testwork and investigations: February 1, 2017;
- Effective date of the Current Mineral Resource (“October 2017 MRE”): July 25, 2017
- Effective date of the Mineral Reserve: August 26, 2017;
- Effective date of incurred project cost reporting: August 31, 2017;
- Effective date of metal prices: October 2, 2017;
- Date of the financial analysis: October 5, 2017.

This Report was prepared as National Instrument 43-101 Technical Report for Falco Resources Ltd. (“Falco”) by Qualified Persons from the following firms: BBA Inc. (“BBA”), Golder Associates Ltd. (“Golder”), WSP Canada Inc. (“WSP”), InnovExplo Inc. (“InnovExplo”) and SNC-Lavalin Stavibel Inc. (“SNC-Lavalin”); collectively the “Report Authors”. The quality of information, conclusions, and estimates contained herein is consistent with the level of effort involved in the Report Authors’ services, based on: i) information available at the time of preparation, ii) data supplied by outside sources, and iii) the assumptions, conditions, and qualifications set forth in this Report. This Report is intended for use by Falco subject to the terms and conditions of its respective contracts with the Report Authors. Except for the purposes legislated under Canadian provincial and territorial securities law, any other use of this Report by any third party is at the sole risk of that party.

As of the effective date of this Report, the QPs are not aware of any known litigation potentially affecting the Project. The QPs did not verify the legality or terms of any underlying agreement(s) that may exist concerning the Project ownership, permits, off-take agreements, license agreements, royalties or other agreement(s) between Falco and any third parties.

The results of this Report are not dependent upon prior agreements concerning the conclusions to be reached, nor are there any undisclosed understandings concerning any future business dealings with Falco and the QPs. The QPs are being paid a fee for their work in accordance with the normal professional consulting practice.

The opinions contained herein are based on information collected throughout the course of the investigations by the QPs, which in turn reflect various technical and economic conditions at the time of writing. Given the nature of the mining business, these conditions can change significantly over relatively short periods of time. Consequently, actual results can be significantly more or less favourable.

## 2.5 Sources of Information

### 2.5.1 General

This Report is based in part on internal company reports, maps, published government reports, company letters and memoranda, and public information, as listed in Chapter 27 “References” of this Report. Sections from reports authored by other consultants may have been directly quoted or summarized in this Report and are so indicated, where appropriate.

This FS has been completed using available information contained in, but not limited to, the following reports, documents and discussions:

- Technical discussions with Falco personnel;
- QP’s personal inspection of the Horne 5 project site;
- Report of mineralogical, metallurgical and grindability characteristics of the Horne 5 deposit, conducted by industry recognized metallurgical testing laboratories on behalf of Falco;
- Resource block model and estimate provided by InnovExplo effective September 26, 2016 (November 2016 MRE);
- A conceptual process flowsheet developed by BBA based on the specific project testwork and similar operations;
- Internal and commercially available databases and cost models;
- Various reports covering site hydrology, hydrogeology, geotechnical, and geochemistry;
- Various reports covering site physical and biological environment;
- Internal unpublished reports received from Falco;
- Specialists in various fields as indicated in Sections 2.5.2 to 2.5.6. They are not considered QPs for the purposes of this NI 43-101 Report;
- Additional information from public domain sources.

Some of the geological and/or technical reports for projects in the vicinity of the Horne 5 deposit were prepared before the implementation of NI 43-101 in 2001. The authors of such reports appear to have been qualified and the information prepared in accordance with standards that were acceptable to the exploration community at the time. However, in some cases the data are incomplete and do not fully meet the current requirements of NI 43-101. The QPs have no known reason to believe that any of the information used to prepare this Report and evaluate the mineral resources presented herein is invalid or contains misrepresentations. The authors have sourced the information for this Report from the collection of documents listed in Chapter 27 (References).

## 2.5.2 BBA

The following individuals provided specialist input to Mr. Colin Hardie, QP:

- Mr. Andrew Falls (Exen Consulting Services) for the Cu/Zn concentrate sales terms and costing information provided in Chapter 19 (Market Studies and Contacts);
- Falco and its external advisors have provided an estimate for the owner's costs and contingencies used in the development of the Project's baseline capital cost estimate found in Chapter 21 (Capital and Operating Costs);
- Falco provided an estimate for the General & Administration costs and Environmental services/labour costs used in the development of the Project's operating cost estimate found in Chapter 21 (Capital and Operating Costs);
- Mr. Claude Catudal (BBA) and Mr. Jocelyn Marcoux (BBA) provided input the industrial standards and norms for the various material, manpower and construction costs used in the development of the process plant capital costs (Chapter 21);
- Falco and its external advisors have provided long-term metal pricing for the project's economic analysis (Chapter 22);
- Mr. Claude Catudal (BBA) provided input to the project execution strategy and schedule as summarized in Chapter 24 (Other Relevant Data and Information).

The following individuals provided specialist input to Mr. Pierre Lacombe, QP:

- Mr. John Rogans (Kemix) provided proprietary CIP circuit simulation data and sizing calculations as the Client's selected sole-source provider of the CIP circuits for the Project;
- Mr. Alex Doll (Alex G. Doll Consulting Ltd.) provided a third-party evaluation of the comminution power requirements and mill sizing. The results were evaluated compared to BBA's own calculations to form the design basis for the Project.

These specialists are not considered as QPs for the purposes of this NI 43-101 Report.

## 2.5.3 SNC-Lavalin

The following individuals provided specialist input to Mr. Luc Gaulin, QP:

- Ms. Manon Th  berge, Architect (TRAME) supported the architectural design in Chapter 18 (Project Infrastructure) due to her extensive experience in the mining industry. She is not considered as QP for the purposes of this NI 43-101 Report;
- Falco and its external advisors have provided an estimate for the infrastructure relocation preproduction capital costs found in Chapter 21 (Capital and Operating Costs).

These specialists are not considered as QPs for the purposes of this NI 43-101 Report.

#### 2.5.4 InnovExplo

The following individuals provided specialist input to Ms. Geneviève Auger, QP, Mr. Patrick Frenette, QP and Mr. Carl Pelletier, QP:

- Mr. Guilhem Servelle (InnovExplo) provided expertise for the geological interpretation, data verification and preparation of the block model;
- Luc Benoit, P. Eng. (ASDR Solutions), Yolaine Lavoie, P. Eng. (Meglab), Patrick Martel, P. Eng. (TechnoSub), Nathalie Gauthier (Groupe EPCM Plus), Charles Gagnon, P. Eng. (Howden Simsmart Technologies), Tim Paquin, Mining Engineering Technologist (BBE) and Robert Hamilton (mobile equipment maintenance) provided project input with their extensive experiences in the mining industry. The specialists supported the work described in Chapters 15 (Mining Reserves), 16 (Mining Methods), 18 (Project Infrastructure) and 21 (Capital and Operating Cost).

These specialists are not considered as QPs for the purposes of this NI 43-101 Report.

#### 2.5.5 Golder

The following individuals provided specialist input to Mr. Bewick QP:

- Patrick Andrieux, Ph.D., P.Eng., Eng. (Andrieux & Associates Geomechanics Consulting, Inc.) provided input on the mine geotechnical considerations (16.2).

The following individuals provided specialist input to Ms. Bertrand, QP and Mr. Serge Ouellet, QP:

- Mostafa Benzaazoua, PhD (UQAT) provided input on the cemented paste backfill material characterization (16.8.2) and on the tailings geochemical characterization (20.2.2).

These specialists are not considered as QPs for the purposes of this NI 43-101 Report.

#### 2.5.6 WSP

The following individuals provided specialist input to Mr. Stéphane Lance, QP:

- Mr. Gareth Thomas, (ATA Engineering) provided input for the dynamic behavior of mine shaft steel sets under dynamic loads from high speed skip operation.

The following individuals provided specialist input to Ms. Claire Hayek, QP:

- Ms. Annie Lavoie (WSP) provided technical guidance during discussions on general paste backfill plant process design.

These specialists are not considered as QPs for the purposes of this NI 43-101 Report.

## 2.6 Site Visits

The following bulleted list describes which Qualified Persons visited the site, the date of the visit, and the general objective of the visit:

- Carl Pelletier (InnovExplo) visited the site on June 4, 2015 accompanied by Claude Bernier (Exploration Manager Horne 5) of Falco. He visited the drill sites and the core logging facility used during the issuer's 2015 drilling program. During this visit, Carl Pelletier reviewed the diamond drill core, along with core logging, sampling protocols and putted the emphasis on review of confirmation drill hole intercepts used for the Mineral Resource Estimation purposes;
- Patrick Frenette (InnovExplo) visited the site on August 30th, 2016, accompanied by Paul Létourneau of Falco, Patrick Martel of TechnoSub and François Girard of Osisko Gold Royalties (with InnovExplo at the time). They visited the Quemont property and infrastructures to discuss the dewatering of Quemont No. 2 shaft.
- Rob Bewick (Golder) visited the site on October 6, 2015 to review the available core, review potential samples, and observe available active drilling locations;
- Mayana Kissiova (Golder) visited the site on November 18, 2015 for a 60 minute helicopter tour of the Mine area and surrounding areas up to Norbec Mine to the North. She also visited the current drilling location close to the Quemont shaft, and visited along the northern limit of the valley between the Glencore smelter and the Quemont shaft area by foot;
- Valérie Bertrand (Golder) visited the Horne 5 Project site on May 21, 2015. The visit included the surface infrastructure of the Horne 5 area, the drilling platform set up at that time, the flooded underground access area and the grounds at one proposed location for water management facilities;
- Michael Bratty (Golder) visited the site on February 16, 2017. The visit included the surface infrastructures of the Horne 5 Mining Complex and the TMF areas;
- Serge Ouellet (Golder) visited the site on August 30, 2016;
- Luc Gaulin (SNC-Lavalin) visited the Horne 5 Project site on August 16, 2016 and November 10, 2016.

As of the effective date of this report, the following QPs have not visited the Horne 5 Project site:

- Pierre Lacombe (ex BBA, now with Lundin Mining Corp.);
- Colin Hardie (BBA);
- Michel Mailloux (Golder);
- Yves Boulianne (Golder);
- Janis Drozdiak (Golder);

- Stéphane Lance (WSP);
- Dominick Turgeon (WSP);
- Claire Hayek (WSP);
- Geneviève Auger (InnovExplo);
- Marie-Claude Dion St-Pierre (WSP)
- Yves Vallières (RIVVAL).

## 2.7 Currency, Units of Measure, and Calculations

Unless otherwise specified or noted, the units used in this Report are metric. Every effort has been made to clearly display the appropriate units being used throughout this Report.

- Currency is in Canadian dollars (“CAD” or “\$”);
- All ounce units are reported in troy ounces, unless otherwise stated; 1 oz (troy) = 31.1 g = 1.1 oz (Imperial);
- All metal prices are expressed in US dollars (“USD”);
- A Canadian dollar (CAD) to United States dollar (USD) exchange rate of 0.78 USD for 1.00 CAD was used;
- All cost estimates have a base date of the second quarter (Q2) of 2017.

This Report includes technical information that required subsequent calculations to derive subtotals, totals and weighted averages. Such calculations inherently involve a degree of rounding and consequently introduce a margin of error. Where these occur, the QPs consider them immaterial.

## 2.8 Acknowledgements

BBA and the other study contributors would like to acknowledge the general support provided by the Osisko Gold Royalty Ltd. (“OGR”) and Falco technical team personnel during this assignment.

The Project benefitted from the specific input of Mr. Christian Laroche, Falco VP Metallurgy; Mr. Francois Vezina, Falco VP Technical Services; Mr. André Le Bel, Falco VP Legal Affairs and Corporate Secretary; Ms. Hélène Cartier, Falco VP Environment & Sustainability; Mr. Francois Girard, OGR Mining Engineering Director; Mr. John-Paul McGrath, OGR Project Manager; Mr. Claude Bernier, P. Geo., Falco Exploration Manager; and Mr. Sylvain Doire, Falco Environmental Manager. Their contributions are gratefully acknowledged.



### 3. RELIANCE ON OTHER EXPERTS

#### 3.1 Introduction

The QPs have relied upon the following other expert reports, which provided information regarding mineral rights, surface rights, property agreements, royalties, taxation and marketing chapters of this Report.

A draft copy of the Report has been reviewed for factual errors by Falco. Any changes made as a result of these reviews did not involve any alteration to the conclusions made.

As of the date of this Report, Falco indicates that there are no known litigations potentially affecting the Horne 5 Project.

The statements and opinions expressed in this document are given in good faith and in the belief that such statements and opinions are neither false nor misleading at the date of this Report.

#### 3.2 Mineral Tenure and Surface Rights

InnovExplo verified the status of all mining titles using the Québec government's online claim management system via the GESTIM website at: <https://gestim.mines.gouv.qc.ca>. The QPs have not otherwise independently reviewed ownership of the Project area and any underlying property agreements, mineral tenure, surface rights, or royalties. The QPs are not expert in legal and land tenure. QPs have relied on data and information provided by Falco and on previously completed technical reports (for details, refer to Chapter 27 – References). Although the QPs have reviewed the available data, these activities only validate a portion of the entire data set.

While exercising all reasonable diligence in checking, confirming and testing the data provided and in formulating its opinion, the QPs have relied on Falco for its project data and for the data of previous operators of the Horne 5 property.

The various agreements under which Falco holds contractual rights to the minerals and ancillary rights for this Project have not been reviewed by the QPs, and the QPs offer no legal opinion as to the validity of the rights of Falco under these agreements. A description of such agreements, the property, and ownership thereof, is provided for general information purposes only. In this regard, the QPs have relied on information supplied by Falco and the work of experts it understands to be appropriately qualified.

This information is used in Chapter 4 of the Report. The information is also used in support of the mineral resource estimate in Chapter 14, the mineral reserve estimate in Chapter 15, and the financial analysis in Chapter 22.

### 3.3 Taxation

Colin Hardie, QP has fully relied upon, and disclaims responsibility for, information supplied by Falco staff and experts retained by Falco for information related to taxation as applied to the financial model. This information is used in support of the financial analysis in Chapter 22 (Economic Analysis).

### 3.4 Commodity Pricing and Markets

The QPs have not independently reviewed the marketing or metal price forecast information. The QPs have fully relied upon, and disclaim responsibility for, information derived from Falco staff and experts retained by Falco through the following documents:

- “Commodity Price Assumptions – October 3, 2017” by Vincent Metcalfe, Falco Resources CFO, October 3, 2017;
- “Horne 5 Project: Zinc/Copper Concentrates Marketing & Logistics” by Exen Consulting Services for Falco Resources, July 25, 2017.

This information is used in Chapter 19 and in support of the mineral reserves estimate in Chapter 15 and the financial analysis in Chapter 22.

Metals marketing and logistics, global concentrate market terms and conditions, are specialized businesses requiring knowledge of supply and demand, economic activity and other factors that are highly specialized. The QPs consider it reasonable to rely upon Mr. Andrew Falls (Exen Consulting Services) who was contracted directly by Falco for such information as the company provides independent analysis and advice on metal concentrate terms, logistics and markets to the mining industry.

## 4. PROPERTY DESCRIPTION AND LOCATION

### 4.1 Location

The Falco property (the “Property”) is located in the Abitibi region, in the central-northwestern part of the province of Québec, Canada. The approximate coordinates of the geographic centre of the Horne 5 deposit (see Figure 4-1) are 79° 00' 35" W and 48° 15' 15" N (UTM coordinates: 647746 E and 5346475 N, NAD 83, Zone 17). The Property covers an area of approximately 30 km by 65 km in the townships of Hébécourt, Duparquet, Destor, Montbray, Duprat, Dufresnoy, Cléricy, La Pause, Dasserat, Beauchastel, Rouyn and Joannes. The Horne 5 deposit is located within the urban limits of the city of Rouyn-Noranda in Rouyn Township; NTS map sheets 32D-03 and 32D-06.

### 4.2 Mining Rights in the Province of Québec

The following discussion on the mining rights in the province of Québec was mostly summarized from Guzun (2012), Gagné and Masson (2013), and from the Act to amend the *Mining Act* (Bill 70; the “Amending Act”) assented on December 10, 2013 (National Assembly, 2013). Refer to Appendix II of the Technical Report and Updated Mineral Resource Estimate for the Horne 5 Deposit issued on March 4, 2016, for a detailed discussion on the mining rights in the province of Québec.

In the province of Québec, mining is principally regulated by the provincial government. The *Ministère de l'Énergie et des Ressources Naturelles du Québec* (“MERN”) is the provincial authority entrusted with the management of mineral substances in Québec. The ownership and granting of mining titles for mineral substances are primarily governed by the *Mining Act* and related regulations. In Québec, land surface rights are a distinct property from mining rights. Rights in or over mineral substances in Québec form part of the domain of the State (the public domain), and are subject to limited exceptions for privately owned mineral substances. Mining titles for mineral substances within the public domain are granted and managed by the MERN. The granting of mining rights for privately owned mineral substances is a matter of private negotiations, although certain aspects of the exploration for and mining of such mineral substances are governed by the *Mining Act*.

---

#### 4.2.1 The Claim

A claim is the only exploration title for mineral substances (other than surface mineral substances, petroleum, natural gas and brine) currently issued in Québec. A claim gives its holder the exclusive right to explore for such mineral substances on the land subject to the claim, but does not entitle its holder to extract mineral substances, except for sampling and only in limited quantities. In order to mine mineral substances, the holder of a claim must obtain a mining lease. The electronic map designation is the most common method of acquiring new claims from the MERN whereby an applicant makes an online selection of available pre-mapped claims. In rare territories, claims can be obtained by staking.

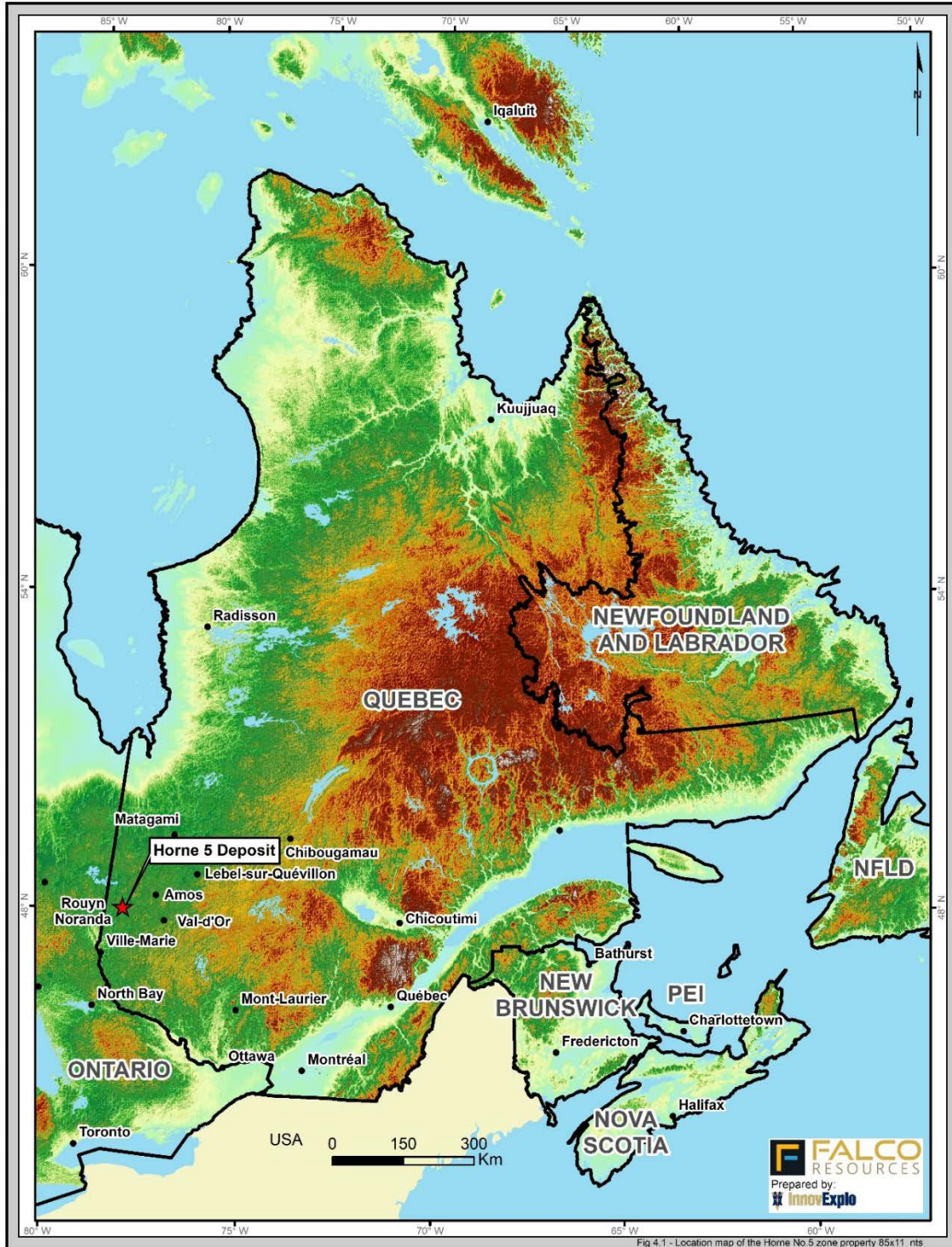

Figure 4-1: Location of the Horne 5 deposit in the province of Québec

#### 4.2.2 The Mining Lease

A mining lease is an extraction (production) mining title that gives its holder the exclusive right to mine mineral substances (other than surface mineral substances, petroleum, natural gas and brine). A mining lease is granted to the holder of one or several claims upon proof of the existence of indicators of the presence of a workable deposit on the area covered by such claims and compliance with other requirements prescribed by the *Mining Act*. A mining lease has an initial term of 20 years, but may be renewed for three additional periods of ten years each. Under certain conditions, a mining lease may be renewed beyond the three statutory renewal periods.

#### 4.2.3 The Mining Concession

A mining concession is an extraction (production) mining title that gives its holder the exclusive right to mine mineral substances (other than surface mineral substances, petroleum, natural gas and brine).

Mining concessions were issued prior to January 1, 1966. After that date, grants of mining concessions were replaced by grants of mining leases. Although similar in certain respects to mining leases, mining concessions granted broader surface and mining rights and were not limited in time. A grantee must commence mining operations within five years from December 10, 2013. As is the case for a holder of a mining lease, a grantee may be required by the government, on reasonable grounds, to maximize the economic benefits within Québec of mining the mineral resources authorized under the concession. The grantee must also, within three years of commencing mining operations and every 20 years thereafter, send the Minister of Natural Resources a scoping and market study with regards to mineral processing in Québec.

#### 4.2.4 Mining Titles of the Property

The portfolio of properties, with respect to which Falco holds certain rights, consists of 2,114 mining claims and 17 mining concessions in non-contiguous blocks covering an aggregate surface area of 68,945.54 hectares (689.5 km<sup>2</sup>). All the mining claims are registered under the name of Falco and/or certain joint venture partners (except for 31 claims registered under the name of Glencore Canada). The 17 mining concessions are registered under the name of Glencore Canada. Certain mining titles are subject to a number of agreements.

The Property is divided into five parts, as described in the purchase agreement of September 12, 2012, between Xstrata Canada Corporation (now Glencore Canada) and Falco, as follows:

1. “Horne Mines Ltd Controlled Properties”
2. “Lac Montsabrai Property”
3. “Noranda Properties”
4. “Third Party Interest Properties”
5. “West Ansil Discovery Property”



The “Here Property”, held by QMX, was excluded from the Falco agreement and therefore is not part of the Property.

Mining concession CM-156PTB (the “Concession”), on which lies the Horne 5 deposit, is part of the Controlled Properties (see Figure 4-3). The Concession has an irregular shape and a surface area of 191.96 hectares (see Table 4-1).

Mining concession CM-243 (“Concession 243”), on which lies the Quemont No. 2 shaft, is part of the Controlled Properties. The Concession 243 has a surface area of 224.90 hectares (see Table 4-1).

***Pursuant to an agreement between Falco and a Third Party, Falco owns rights to the minerals located below 200 metres from the surface of mining concession CM-156PTB, where the Horne 5 deposit is located. Under the agreement, ownership of the mining concession remains with the Third Party.***

***In order to access the Horne 5 Project, Falco must obtain one or more licenses from the Third Party, which may not be unreasonably withheld, but which may be subject to conditions that the Third Party may require in its sole discretion. These conditions may include the provision of a performance bond or other assurance to the Third Party and the indemnification of the Third Party by Falco. The agreement with the Third Party stipulates, among other things, that the license shall be subject to reasonable conditions which may include, among other things, that activities at Horne 5 will be subordinated to the current use of the surface lands and subject to priority, as established in such party’s sole discretion, over such activities. Any license may provide for, among other things, access to and the right to use the infrastructure owned by the Third Party, including the Quemont No. 2 shaft (located on mining concession CM-243 held by such Third Party) and some specific underground infrastructure in the former Quemont and Horne mines.***

***While Falco believes that it should be able to timely obtain the licenses from the Third Party, there can be no assurance that any such license will be granted, or if granted will be on terms acceptable to Falco and in a timely manner.***

***Although Falco believes that it has taken reasonable measures to ensure proper title to its assets, there is no guarantee that title to any of assets will not be challenged or impugned.***

Table 4-1: Ownership of Horne 5 mining concessions (CM-156PTB and CM-243)

Title No.	Area (ha)	NTS	Township	Status
CM-156PTB	191.96	32D03 and 32D06	Rouyn	Active
	<b>Owner (according to GESTIM)</b>		<b>Registered</b>	
	100% Glencore Canada Corporation		December 10, 1924	
Title No.	Area (ha)	NTS	Township	Status
CM-243	224.90	32D06 and 32D07	Rouyn	Active
	<b>Owner (according to GESTIM)</b>		<b>Registered</b>	
	100% Glencore Canada Corporation		February 11, 1929	



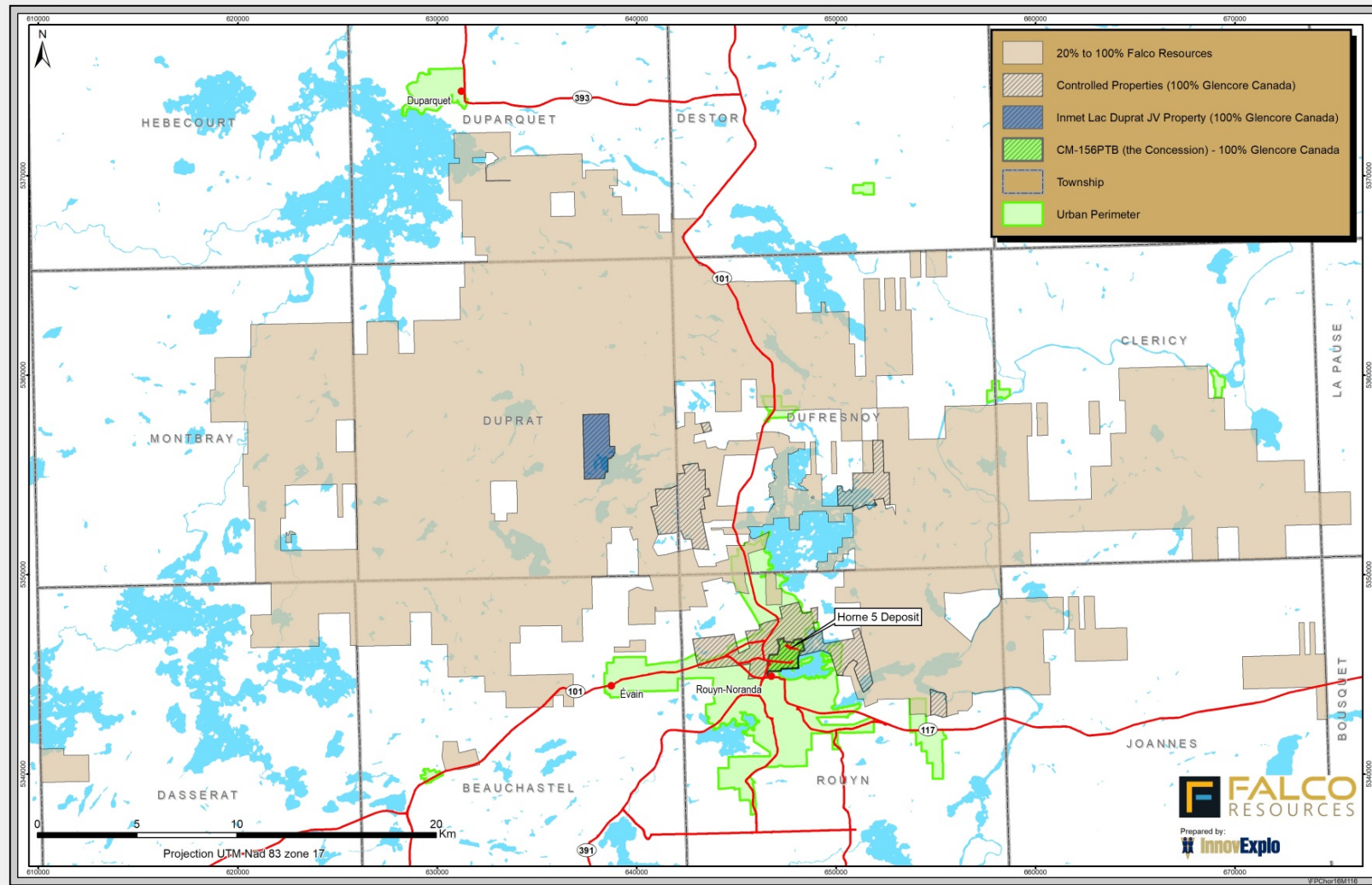

Figure 4-2: Location map for the Falco Property

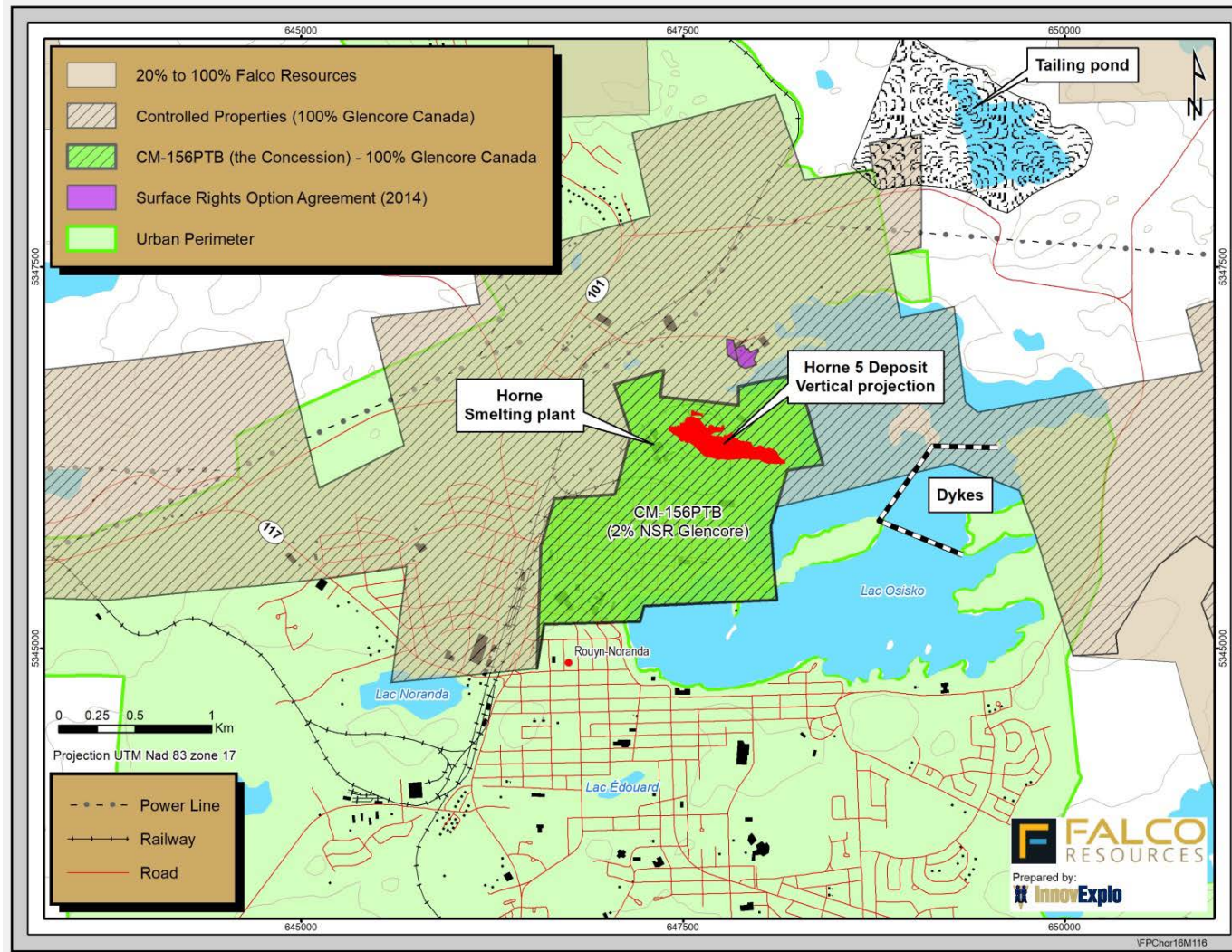

Figure 4-3: Location of the Horne 5 deposit within the Concession

#### 4.2.5 Horne Deposit Owner History

The claim that includes the Horne 5 deposit was staked by Edmund H. Horne for the Tremoy Lake Prospecting Syndicate in 1920. In 1922, it was transferred to Noranda Mines Ltd. (“Noranda”).

Mining of the historic Horne orebodies took place from 1927 to July 1976, with Noranda as the only owner. During this period, Noranda held several exploration and mining properties, often in joint ventures, throughout the Rouyn-Noranda mining camp.

In 2005, after acquiring a large interest in the mining company Falconbridge Limited (“Falconbridge”), Noranda completed a merger with Falconbridge, essentially purchasing it outright. The combined company continued under the name Falconbridge Limited.

In 2006, Falconbridge was acquired by the Swiss-based mining company Xstrata plc (“Xstrata”), already 19.9% owner of Falconbridge. In Canada, the Xstrata plc name was registered in October of 2007 as Xstrata Canada Corp. (“Xstrata Canada”). The Canadian operations of the copper division (“Xstrata Copper”) comprised the Kidd Operations, the Horne Smelter, the Canadian Copper Refinery (“CCR”), Xstrata Recycling and closed sites.

In 2012, Glencore Xstrata plc (“Glencore Xstrata”) was formed following the merger of Glencore International plc and Xstrata plc.

In 2013, Glencore Xstrata’s subsidiary, Xstrata Canada, changed its name to Glencore Canada Corporation.

#### 4.2.6 Agreements and Encumbrance

On August 2, 2011, by means of a deed of transfer, Xstrata Copper (now Glencore Canada) assigned interests in, and rights relating to, certain claims, mining leases and mining concessions around the Rouyn-Noranda mining camp (the “Transferred Properties”), to Alexis Minerals Corporation (Alexis; now QMX Gold Corporation).

The deed of transfer incorporated a clause confirming the primacy of the terms of an agreement of purchase and sale entered into between Xstrata Copper and Alexis as of March 28, 2011. The original deed of transfer between Xstrata Copper and Alexis can be found on the Québec government’s GESTIM database at the following address:

[http://gestim.mines.gouv.qc.ca/documents/54357\\_000000400.pdf](http://gestim.mines.gouv.qc.ca/documents/54357_000000400.pdf).

Highlights of such original deed of transfer are as follows:

- Alexis paid Xstrata Copper \$200,000;
- Xstrata Copper retained its back-in right to acquire a 65% interest on any base metal deposit containing more than 350,000 tonnes of copper metal equivalent determined pursuant to a NI 43-101 compliant resource, under the following conditions:



- Alexis would be paid three times the project-specific exploration and development expenditures;
- Alexis would be paid three times the Rouyn regional base metal exploration expenditures up to a maximum of \$20 million;
- Xstrata Copper must complete a NI 43-101 compliant feasibility study, within a specified period and at no cost to Alexis;
- Alexis would retain a 35% interest, would receive a 6-month financing period subsequent to a production decision, and would participate in a JV management committee where unanimous agreement is required on critical mining decisions.
- The aforementioned back-in right did not apply to any gold deposit, which is defined as a deposit where the value of gold and silver are three times greater than the value of base metals using 6-month average metal prices at closing, as defined at the date of the agreement. As such, gold deposits were solely to the Alexis account;
- Xstrata Copper retained a 1–2% NSR on all metals on mineral claims transferred to Alexis. Where historical royalties exist, the combined royalty is capped at 3–4%. In areas with no prior royalties, the NSR is capped at 2%;
- Xstrata Copper has the right to explore for and exploit smelter materials (e.g. flux) in all areas. Should smelter materials be mined from the Alexis properties, Alexis will receive a royalty of \$0.50 per tonne plus 50% of any gold that might be recovered;
- Subsequent to closure, Alexis and Xstrata Copper worked cooperatively together to review the underlying agreements made over the last 40 years to develop this unique property package, in order to resolve any third-party rights or obligations;
- The West Ansil Property, comprising ten claims, was excluded from the agreement and continued as a 50/50 JV between Alexis and Xstrata Copper;
- Xstrata Copper retained the right of first refusal for custom milling and smelting of base metal production;
- All regional areas of interest applicable under the historical JV were cancelled.

According to the original agreement between Xstrata Copper and Alexis Minerals, the mining titles included in the Transferred Properties were, at that time, divided into the three subdivisions listed below, which in turn were divided into subgroups (not listed):

- Part I: The Noranda Properties (former Noranda mining titles in townships in the Rouyn-Noranda mining camp);
- Part II: Third Party Interest Properties (properties with mining title interests belonging to one or more third parties, or in joint ventures with one or more parties);
- Part III: Controlled Properties (properties controlled by Noranda, now Glencore Canada; mostly mining concessions or mining leases on or around former Noranda producers).

The mining titles included in the Controlled Properties (Part III) are subject to rights in favour of Falco only insofar as the mineral rights contained at depths of more than 200 m below the surface. Falco is therefore not the owner of the mining rights, nor does it have the right to minerals on the first 200 m below the surface, which remains the property of Glencore Canada.

***As previously stated, pursuant to an agreement between Falco and a Third Party, Falco owns rights to the minerals located below 200 metres from the surface of mining concession CM-156 PTB, where the Horne 5 deposit is located. Under the agreement, ownership of the mining concession remains with the Third Party.***

***In order to access the Horne 5 Project, Falco must obtain one or more licenses from the Third Party, which may not be unreasonably withheld, but which may be subject to conditions that the Third Party may require in its sole discretion. These conditions may include the provision of a performance bond or other assurance to the Third Party and the indemnification of the Third Party by Falco. The agreement with the Third Party stipulates, among other things, that the license shall be subject to reasonable conditions which may include, among other things, that activities at Horne 5 will be subordinated to the current use of the surface lands and subject to priority, as established in such party's sole discretion, over such activities. Any license may provide for, among other things, access to and the right to use the infrastructure owned by the Third Party, including the Quemont No. 2 shaft (located on mining concession CM-243 held by such Third Party) and some specific underground infrastructure in the former Quemont and Horne mines.***

***While Falco believes that it should be able to timely obtain the licenses from the Third Party, there can be no assurance that any such license will be granted, or if granted will be on terms acceptable to Falco and in a timely manner.***

The Controlled Properties group was divided into three subgroups: Group "A", Group "C", and Group "I", themselves divided into subgroups of properties. Within Group "A", the "Horne Mines Ltd Controlled Property" is composed of seven mining concessions that include former producers Don Rouyn, Chadbourne, Horne and Quemont. The Horne mine lies almost entirely within the boundaries of the Concession. The Horne 5 deposit lies entirely within the Concession's boundaries, below a depth of 200 m from surface.

In June of 2012, Alexis changed its name to QMX Gold Corporation ("QMX").

In September of 2012, QMX sold and transferred to Druk the rights to the Transferred Properties. The terms of the transaction are summarized as follows:

- Purchase price of \$5,000,000;
- The issuance of 7,000,000 common shares of Druk from treasury registered in the name of QMX or its nominee at a deemed price of \$0.25 per share;

- QMX shall retain a 10% equity interest in Druk through the granting by Druk of a first right to purchase such shares or securities as to allow QMX to maintain its then current pro-rata interest;
- The granting by Druk of the right to appoint, on the closing date, one person to the board of directors of Druk.

That same month, Druk changed its name to Falco Pacific Resource Group Inc. (now Falco Resources Ltd). In GESTIM, the mining titles of the Controlled Properties are registered 100% to Glencore Canada. Glencore Canada is responsible for managing the mining titles on the Controlled Properties, as well as on properties with shared interests with Falco.

Falco retained full ownership of mineral rights below 200 m below the surface, as Glencore Canada (which owns the back-in right to the Horne 5 deposit) had elected not to exercise its back-in right. Glencore Canada retains a 2% net smelter return royalty on all metals produced and has rights of first refusal with respect to purchase or toll process all or any portion of the concentrates and other mineral products. Glencore Canada still owns the mining rights to the Concession including 100% of the minerals contained between the surface and a depth of 200 m below the surface and it further owns part of the surface rights on the Concession;

#### 4.2.7 Royalties

The Concession is subject to a 2% NSR in favour of Glencore Canada (see Figure 4-3).

#### 4.3 Surface Rights and Option Agreements

In September 2014, Falco entered into an option agreement with the City of Rouyn-Noranda to acquire surface rights to land above the Horne 5 deposit (the “City Property”) and immediately adjacent to the Horne smelter. This option agreement provided Falco with a 5-year option to purchase additional land near the Horne 5 Project. On June 29, 2017, Falco exercised this option, purchasing the City Property for \$2,946,900, for which Falco had already paid a non-refundable deposit of \$1,000,000. Of the two remaining instalments, the first payment for \$1,000,000 is payable by January 1, 2018, and the final payment of \$946,900 is payable by January 1, 2019.

In January 2017, Falco entered into an option agreement to acquire land and buildings adjacent to the Horne 5 Project. The purchase price was \$5,400,000, of which a \$75,000 non-refundable deposit was paid upon signing such agreement. On July 5, 2017, Falco exercised this option and completed a second payment of \$2,625,000. The remaining balance of \$2,700,000 is payable by February 1, 2018.

In May 2017, Falco entered into an option agreement with a third party to acquire land and buildings adjacent to the Horne 5 Project. The total purchase price was \$667,460, of which a \$300,000 non-refundable deposit was paid on the signing of such option agreement. The remaining balance is payable by January 31, 2018, if Falco decides to exercise its option.

On October 5, 2017, the Company completed the acquisition of the Donalda property, located near the Horne 5 Project from Globex Mining Enterprises Inc. In consideration, Falco paid \$300,000 in cash and issue 350,000 units to Globex Mining Enterprises. Each Unit consists of one common share of Falco and one common share purchase warrant of Falco. Each common share purchase warrant will entitle the holder thereof to purchase one Common Share of the Company at a price of \$1.15 per Common Share, for a period of 5 years following the closing date. Additionally, Falco granted Globex Mining Enterprises a 2.5% gross metal royalty on all mineral production from Donalda and will transfer a 100% ownership of Falco's Dickenson property located on the east side and adjoining Globex Mining Enterprise's Francoeur/Arntfield gold property. The total consideration is valued at \$1.1 million.

#### 4.4 Communication and Consultation with the Community

Since the last mineral resource estimate published in November 2016, various communication and consultation activities have taken place within the community and with municipal representatives, political representatives, and members of the Board of Trade of Rouyn-Noranda.

These activities can be grouped into three distinct themes:

- Communication activities organized by Falco in order to disclose project information and results;
- Meetings between Falco and municipal representatives, political representatives, and members of the Board of Trade to explain project details;
- Meetings between Falco and a committee representing a neighbourhood near the mine site in order to explain the current or anticipated exploration work taking place to the north of the neighborhood.

#### 4.5 Permits, Infrastructure and Environmental Liabilities

##### 4.5.1 Permits

Permitting and expenditures to be considered can include construction to access the Horne 5 deposit. If Falco intends to perform exploration work or mining activities on the Concession or on Concession 243, permitting and one or more licence agreements with the Third Party mining right owner will have to be entered into, as previously stated.

All access to the Horne smelting and refining plant site must be approved and supervised by Glencore Canada, including consultation of historical data (maps, reports) kept in the on-site archive.

#### 4.5.2 Enhanced Role of Municipal Authorities

The Concession is located within an urbanized perimeter. The Amending Act also amends an Act respecting land use planning and development (the “Planning Act”) such that each regional county municipality (“RCM”) is granted the power to delimit, on its Land Use and Development Plan for its territory, any mining-incompatible areas (Gagné and Masson, 2013). Pursuant to the Amending Act, these territories are defined as being those in which the viability of activities would be compromised by the impacts of mining activities. The government’s policy direction on how to delimit these territories has not yet been drawn up, and the stated intention of the Minister is to proceed with this exercise in collaboration with, among others, the associations representing the Québec mining industry and those representing the municipal sector.

#### 4.5.3 Infrastructure and Environmental Liabilities

Existing surface features and infrastructure on the Concession and its surroundings includes the following:

- The Glencore Canada smelting and refining facilities;
- The city of Rouyn-Noranda, including public institution buildings such as hospitals, schools, etc.;
- The Marcel-Baril industrial park;
- Old tailings from the Horne and Quemont former producers;
- Regional highways and local roads;
- A railroad and a station yard;
- Osisko Lake;
- Hydro-Québec main substation;
- Airport Facilities.

Except pursuant to licences granted by Glencore Canada, to the extent applicable, Falco is not responsible for any current environmental liability relating to the surface rights, the mineral rights and the minerals contained at a depth of less than 200 m below the surface of the Concession and of Concession 243. However, upon commencement of the development and operations at Horne 5, Falco will have statutory environmental liabilities for such operations.



#### 4.6 Comments on Chapter 4

In the opinion of the QPs, the following interpretations and conclusions are valid:

- Pursuant to an agreement between Falco and the Third Party, Falco owns rights to the minerals located below 200 metres from the surface of the Concession, where the Horne 5 deposit is located. Falco also owns certain surface rights surrounding the Quemont No. 2 shaft located on the Concession 243. Under the agreement, ownership of the Concession and Concession 243 remains with the Third Party;
- Glencore Canada owns the mining rights to the Concession and to Concession 243 including 100% of the rights to the minerals contained between the surface and a depth of 200 m below the surface;
- The Concession is subject to a 2% NSR Royalty in favour of Glencore Canada;
- Permitting and license agreements with mining rights owner Glencore Canada is necessary if Falco is to perform exploration work or mining activities on the Concession and Concession 243;
- The Concession and Concession 243 is located within an urbanized perimeter;
- Except pursuant to licences granted by Glencore Canada, as applicable, Falco is not responsible for any current environmental liability relating to the surface rights, the mineral rights and the minerals contained at a depth of less than 200 m below the surface of the Concession and Concession 243. However, upon commencement of the development and operations at Horne 5, Falco will have statutory environmental liabilities for such operations.

InnovExplo is not aware of any other royalties, environmental liabilities, permits, or issues with respect to the Concession and Concession 243. Other than the rights granted under the agreements entered into with Glencore Canada with respect to the Concession and Concession 243 as described above, the authors are not aware if permits or authorizations have been granted to Falco with respect to future work on the Concession.

## 5. ACCESSIBILITY, CLIMATE, LOCAL RESOURCES, INFRASTRUCTURE AND PHYSIOGRAPHY

### 5.1 Accessibility

The Concession is accessible year-round via Provincial Highways 117 and 101 (see Figure 5-1). The Concession is located within Rouyn-Noranda's urban perimeter in the Marcel-Baril industrial park, therefore providing excellent access on the paved roads of Rouyn-Noranda. Some gravel roads are also present on the Horne smelter site.

### 5.2 Local Resources and Infrastructure

Rouyn-Noranda is a medium-size city with a population of approximately 41,500. It is the Abitibi region's administrative capital, and houses some of Québec's government regional offices. Rouyn-Noranda has a hospital, a college and a university, as well as a commercial airport with regularly scheduled flights to Montreal.

Rouyn-Noranda was born with the discovery of the Horne deposit in the 1920s and its economy evolved essentially around the mines and the smelter until the 1980s. When the last mine inside the town closed its operations, the town turned itself towards developing the service sector. Today, Rouyn-Noranda is recognized as a service centre for the Abitibi-Témiscamingue and Nord-du-Québec regions, being home to many federal and provincial government offices (*Hydro-Québec, Sureté du Québec, Ministère du Développement durable, de l'Environnement et de la Lutte contre les changements climatiques* ("MDDELCC"), etc.). The town developed the education sector and now has a University campus (*Université du Québec en Abitibi-Témiscamingue* ("UQAT")) and a College (*Collège de l'Abitibi-Témiscamingue*) of approximately 3,000 students. It is also highly recognized on a national level for the many cultural events (*Festival Musique Émergente, Festival International du Cinéma, Festival Osisko en Lumière*, etc.).

The Horne smelter is still in operation; it is the only stand-alone active copper smelter in Canada. It is the world's largest processor of electronic scrap containing copper and precious metals. The smelter is a custom copper smelter that uses both copper concentrates and precious metal-bearing recyclable materials as its feedstock to produce a 99.1% copper anode. The smelter has the capacity to process 840,000 tonnes of copper and precious metal-bearing materials per year.

The town also offers several mining industry services, such as geological and engineering consulting firms, and drilling and mining suppliers. An experienced mining workforce is available in Rouyn-Noranda, as well as in the nearby mining towns such as Val-d'Or, La Sarre, Amos, Matagami and Chibougamau.

Electrical power and water are available in the vicinity of the Concession. Electricity is supplied by Hydro-Québec, the province’s major supplier of electricity and 100% owned by the Québec government. Water is readily accessible on the Horne smelter site.

A railway runs near the Property and connects to the national network owned by Canadian National Railway Co.

Figure 5-2 shows some of the available infrastructure near the Concession.

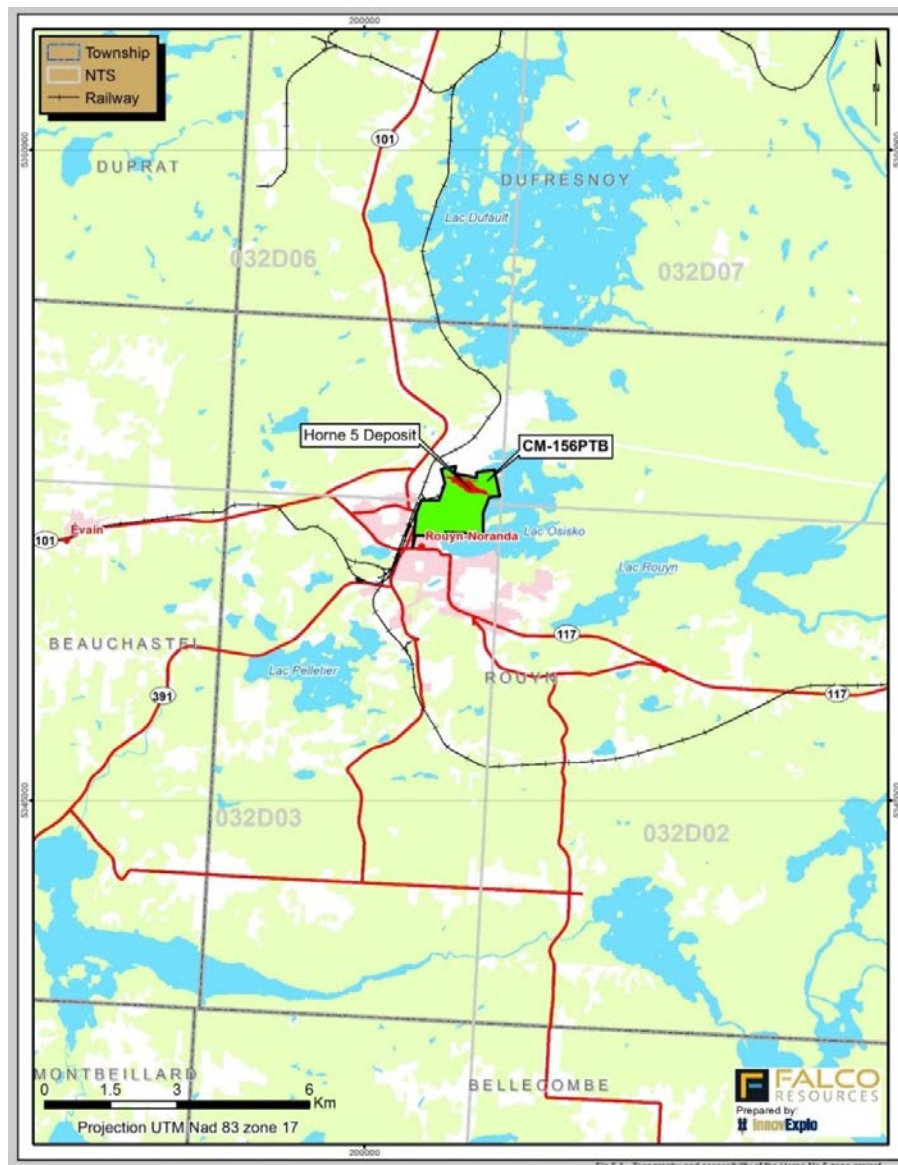

Figure 5-1: Topography and accessibility of mining concession CM-156TP



Figure 5-2: Aerial view of the available infrastructure near the proposed Horne 5 Mining Complex

### 5.3 Climate

The climate is continental with cold dry winters and warm summers. Winter temperatures average  $-17^{\circ}\text{C}$  with lows down to  $-40^{\circ}\text{C}$  in January; summer temperatures average  $17^{\circ}\text{C}$  with highs up to  $35^{\circ}\text{C}$  in July. Annual precipitation is around 900 mm. Snow falls from mid-November to mid-April.

Mining and drilling operations can take place year-round, whereas surface exploration work (mapping, channel sampling) can only be carried out from mid-April to mid-November.

### 5.4 Physiography

The area surrounding the Concession is covered by a variety of Pleistocene glacial and glaciolacustrine sediments. The Concession is characterized by a small rounded hill rising about 25 m above Lake Osisko and the surrounding land. Bedrock crops out in places on the hilltop, the site of the Horne smelter. Overlying Quaternary surficial sediments were either removed or relocated during past industrial activities, and slag (smelting residue) is widespread. Some old mine tailings, on lower ground, cover the northern edge and the eastern side of the Concession, along Lake Osisko. Limited areas are covered by bushes and small trees. The topography on the Concession has altitudes ranging from 291 m.a.s.l. (Lake Osisko) to 325 m.a.s.l.



## 6. HISTORY

### 6.1 Noranda Period (1920 - 2011)

The following chronological overview of historical work in the area of the Horne 5 deposit was taken mainly from Cattalini et al., 1993; Gibson et al., 2000; and Gibson and Galley, 2007.

The mineralization of the Horne mine was discovered by E. H. Horne. Horne began exploring central-northwest Québec in 1911. From Kirkland Lake, he made three trips to Lake Osisko (known today as Lac Tremoy) in Québec via the Ottawa and Kinojevis rivers in 1911, 1914, and 1917. During these early visits, Horne prospected the area around Lake Osisko, noting mineralized rhyolite outcrops. His samples did not yield significant gold values, but he was encouraged by the favorable geology surrounding Lake Osisko and raised \$225 from ten individuals to form the Tremoy Lake Prospecting Syndicate (the “TLP Syndicate”) in 1920. Horne and partner Miller returned to Lake Osisko and staked a 70-acre claim for the TLP Syndicate, which would ultimately contain about 95% of all the ore extracted from the Horne mine.

In 1921, sampling near what later became the Horne No. 2 and No. 1 shaft zones yielded gold ranges of 5.1 g/t to 8.6 g/t Au and 25.7 g/t to 54.9 g/t Au, respectively (gold at the time was worth 20.67 USD/oz). These encouraging values led to the staking of an additional 160 acres that same year, and an additional 400 acres in 1922. Prospecting in 1922 yielded additional mineralization, including 17.1 g/t Au over 0.61 m, and this discovery later became known as the A orebody.

The Thomson-Chadbourne Syndicate (“T-C Syndicate”) acquired the TLP Syndicate claims in August of 1922. The T-C Syndicate had been formed in 1921 by two American mining engineers, S.C. Thomson and H.W. Chadbourne, to explore northern Ontario, particularly the Kirkland Lake area. According to the terms of the deal, the T-C Syndicate optioned a 90% interest in the Lake Osisko property for an aggregate amount of \$320,000, with \$5,000 payable at the beginning of January 1923, followed by \$5,000 every six months until January 15, 1928, with \$265,000 payable on the final option date. The remaining 10% interest eventually took the form of shares in Noranda, the Canadian operating company incorporated in December 1922 to finance the T-C Syndicate’s exploration and development of the Lake Osisko property. In the summer and fall of 1922, the T-C Syndicate acquired new ground known as the Powell and Chadbourne claims. In 1923, Noranda initially focused on the Powell and then Chadbourne claims because they were considered more prospective than the Horne claims and were wholly held by Noranda. While the first shaft in northwestern Québec was being sunk on the Chadbourne claims, a single drill rig was moved from the Powell claims to the Horne claims to test known surface showings on a property that was costing the syndicate substantial option payments. In late August 1923, the second drill hole (collared in massive sulphide) intersected 40 m averaging 9.94 g/t Au, 32.2 g/t Ag and 5.61% Cu. This was the Horne mine discovery hole. The intersected sulphide lens would eventually be known as the D orebody.

Following the 1923 discovery, the Horne property was aggressively explored. By the end of 1924, a total of 554,000 st of Proven and Indicated ore grading 9.25 g/t Au and 5.66% Cu had been delineated (Roberts, 1956).

***Note: These “resources” or “reserves” are historical in nature and should not be relied upon. It is unlikely they comply with current NI 43-101 criteria or CIM Standards and Definitions, and they have not been verified to determine their relevance or reliability. They are included in this section for illustrative purposes only and should not be disclosed out of context. InnovExplo did not review the database, key assumptions, parameters or methods used for this estimate.***

Based on the reserves, a positive development decision was made, and the sinking of the No. 1 and No. 2 shafts was initiated in 1925, followed by the sinking of the No. 3 shaft in 1926. Plans for a smelter were drawn up. In 1925, exploration work included mapping, trenching and electrical surveying. The only mining development consisted of sinking shafts No. 1 and No. 2 to depths of 328 ft and 158 ft, respectively. The two shafts were linked by a drift at the 100 ft level. Diamond drilling was done from both surface and underground workings for orebodies B and H (the only ones known at the time), defining them down to a depth of 300 ft.

In 1927, the discovery of lenses C, D, E and K at 300 ft pushed the company to drill deeper. Commercial production at the Horne mine started in late 1927 and, in that first year, the mine yielded 752 oz of gold and 227 st of copper. The smelter came on stream in December 1927, and 9,743 st of ore were processed by year-end. Reserves stood at 1,087,200 st grading 9.02 g/t Au and 6.73% Cu (Roberts, 1956).

***Note: These “reserves” are historical in nature and should not be relied upon. It is unlikely they comply with current NI 43-101 criteria or CIM Standards and Definitions, and they have not been verified to determine their relevance or reliability. They are included in this section for illustrative purposes only and should not be disclosed out of context. InnovExplo did not review the database, key assumptions, parameters or methods used for this estimate.***

Mine workings would eventually extend to a depth of 2,440 m (8,000 ft), although nearly all the production came from the Upper H and Lower H orebodies in the upper 950 m (3,115 ft) of the mine.

The Horne mine remained in continuous production until 1976, although there were sharp reductions in production due to a labour shortage following World War II and a major strike in 1953.

Gold and copper production from 1927 to 1944 (18 years) almost equaled the production of the subsequent 32 years (1945–1976), partly due to increased mining depths. Bearing in mind that the total metal production for the period 1969 to 1976 is calculated, not measured, the Horne mine yielded a total historical production of 1,133,830 st of copper, more than 17,330,000 oz of silver and 8,942,470 oz of gold from 53,706,990 st of ore until mine closure in 1976. The silver

production figure is a minimum estimate since silver production records only cover the period from 1927 to 1959. A later phase of production (the 1986–1989 REMnant NORanda (“REM NOR”) project; see below) exploited gold-only flux ore from the upper levels of the Horne mine. The REM NOR project added an additional historical production of 102,170 oz of gold (calculated oz) from 604,000 tonnes of ore. REM NOR increased the total historical gold production from the Horne mine to 9,044,640 oz.

***Note: These “reserves” are historical in nature and should not be relied upon. It is unlikely they comply with current NI 43-101 criteria or CIM Standards and Definitions, and they have not been verified to determine their relevance or reliability. They are included in this section for illustrative purposes only and should not be disclosed out of context. InnovExplo did not review the database, key assumptions, parameters or methods used for this estimate.***

In 1928, shaft No. 3 was deepened to 1,040 ft and stations were developed at levels 600 ft, 725 ft, 850 ft and 975 ft. At this last level, the shaft passed through a high-grade Au-Cu bulge (100 ft x 500 ft) in the H orebody. Drilling from underground upper levels defined the high-grade H lens down to the 1300 ft level. Shaft No. 4 was sunk at 268 ft and linked to the No. 3 shaft at the 100 ft level. Several discoveries were added, including the silica flux body No. 20 and high-grade material between levels 1475 ft and 1625 ft. This last discovery would become the most important of the Horne mine orebodies: the lower H orebody (also named No. 21).

In 1932, shaft No. 4 was deepened to 2,560 ft. Drifts and drilling added considerable tonnage to the reserves, including 5,750,000 st of direct smelting ore above the 2,475 ft level, grading 0.16 oz/t and 7.6% Cu (Figure 6-1). To this total, 15,800,000 st of ore grading 0.20 oz/t Au and 1.16% Cu (requiring concentration) were added in the reserves.

***Note: These “reserves” are historical in nature and should not be relied upon. It is unlikely they comply with current NI 43-101 criteria or CIM Standards and Definitions, and they have not been verified to determine their relevance or reliability. They are included in this section for illustrative purposes only and should not be disclosed out of context. InnovExplo did not review the database, key assumptions, parameters or methods used for this estimate.***

The plunge of metal prices and depletion of high-grade reserves pushed the company to increase and optimize the concentration and smelting facilities (Hall, 1937).

It is not clear at which point geologists realized the existence of the Horne 5 deposit. In his PhD thesis of 1933, Price provides some information on the Horne 5 deposit. Plans from level 21 show the lens to the east of the north-south diabase dike.

In 1934, shaft No. 4 was deepened to 3,094 ft. Most of the exploration work aimed to delimit and develop the orebody under the 2,475 ft level west of the No. 4 shaft where the company expected to build shaft No. 5. The Lower H orebody extended deeper than expected. At the 2,725 ft level, it still had a thickness of 100 ft and a width of 500 ft with grades of 6.11% Cu and 0.38 oz/t Au.

In 1935, shaft No. 5 was started from surface and was completed to the 2,146 ft level. An ambitious exploration program was started in 1936 to define the Horne 5 deposit between levels 2,975 ft and 4,000 ft, corresponding to the upper portion of mineralization. Drifts with 250 ft spacing were planned over eight levels, with a 125-ft interval.

In 1938, levels 3,475 ft, 3,725 ft and 3,975 ft in the Horne 5 deposit were lengthened up to 1,900 ft to the east of the No. 5 shaft. The orebody was recognized over a width of at least 2,000 ft on level 3,975 ft.

The metal recoveries for the year 1932 were  
 \$11,752,628.99.

The total dividends paid by the company since commencement of operations to the end of 1932 is  
 \$9,700,077.00.

The published ore reserves as at Dec.31st, 1932 are given in the following table. They represent the proven ore down to the 2475 foot (21st.) Level:

	Tons.	Gold per ton. \$	Copper %.
Direct Smelting ore	5,750,000	\$3.27	7.60
Concentrating ore.	15,800,000.	\$4.00	1.16.
Siliceous fluxing ore.	900,000.	\$4.17	0.28.

Figure 6-1: Excerpt from Price (1933) showing details of the 1932 ore reserve estimate for the Horne mine  
 In 1932, the average gold price was 20.69 USD

**Note:** These “ore reserves” are historical in nature and should not be relied upon. It is unlikely they comply with current NI 43-101 criteria or CIM Standards and Definitions, and they have not been verified to determine their relevance or reliability. They are included in this section for illustrative purposes only and should not be disclosed out of context. InnovExplo did not review the database, key assumptions, parameters or methods used for this ore reserve statement.



In 1939, internal shaft No. 6 was started at level 2,975 ft and reached level 3,975 ft by the end of the year. Exploration continued on a mineralized zone found on level 3,975 ft in 1938. One drill hole in this zone cut 45 ft at an average grade of 0.34 oz/t Au, and another cut 165 ft at 0.21 oz/t Au.

In 1942, exploration drifts were driven west of shaft No. 6 at levels 4,475 ft, 4,975 ft and 5,475 ft. Ore shoots are identified between these levels. Gold and copper mineralizations identified above level 2,975 ft were estimated to be sufficient to sustain production for 15 years.

In 1944, the shortage of workmen and the scarcity of materials considerably slowed exploration over the first six months and stopped it completely for the rest of the year. Several ore shoots were identified in the Horne 5 deposit. At level 5,975 ft, one of these shoots was 400 ft x 70 ft with grades of 0.84% Cu and 0.12 oz/t Au.

In 1951, the sinking of internal shaft No. 7 started and stopped at level 23. It allowed for the exploitation of several stopes in the lower H orebody. A total of 56,551 ft (17,237 m) of underground drilling led to a more precise definition of orebody morphology, whereas surface drilling did not yield any positive results.

Resource estimates for the Horne 5 deposit were calculated in 1954, 1955 and 1956 (Price, 1954; 1955; 1956). A density study by Price in 1956 allowed corrections to be applied to the estimated tonnage. His corrected estimates are provided in Table 6-1.

**Table 6-1: Resource estimates<sup>(1)</sup> for the Horne 5 deposit  
(Price, 1954, 1955 and 1956)**

Year	Levels	Short tons (st)	Gold oz/t	Cu%	Zn%
1954	27 to 39	39,397,000	0.038	0.09	0.48
1955	21 to 39	55,239,000	0.038	0.10	0.59
1956	21 to 39	63,933,000	0.037	0.11	0.59

<sup>(1)</sup> These “resources” are historical in nature and should not be relied upon. It is unlikely they comply with current NI 43-101 criteria or CIM Standards and Definitions, and they have not been verified to determine their relevance or reliability. They are included in this section for illustrative purposes only and should not be disclosed out of context. InnovExplo did not review the database, key assumptions, parameters or methods used for this estimate.

In 1959, the objective of underground exploration was to locate new orebodies below a depth of 6,000 ft. Apart from small gold ore shoots, it seemed at the time that the Horne 5 deposit had only marginal value between depths of 3,000 ft and 6,000 ft. Reserves from these gold zones totalled 320,000 st at 0.12 oz/t Au and 0.7% Cu.

***Note: These “reserves” are historical in nature and should not be relied upon. It is unlikely they comply with current NI 43-101 criteria or CIM Standards and Definitions, and they have not been verified to determine their relevance or reliability. They are included in this section for illustrative purposes only and should not be disclosed out of context. InnovExplo did not review the database, key assumptions, parameters or methods used for this estimate.***

A new exploration program was planned for 1961–1965 to explore depths between 6,000 ft and 8,000 ft.

In 1960, the sinking of internal shaft No. 8 started at a depth 6,000 ft and was completed in 1962. Stations were cut at depths of 6,500 ft and 7,000 ft to allow drifting on the Horne 5 deposit. Drifting for the No. 93 gold zone started in 1964 on levels 43 and 45, and a drive was cut on level 47 to reach the No. 94 gold zone and allow definition drilling. In March of 1964, drilling was completed on the No. 93 gold zone, demonstrating a potentially profitable operation. In May of that same year, sampling of the raise in the No. 93 gold zone was completed with somewhat erratic results. Test holes were drilled to check the results.

Between 1947 and 1963, exhaustive metallurgical testing was conducted on material from the Horne 5 deposit. Seventy-six (76) bulk samples, totalling approximately 110 st of material, were sent to the concentrator for testing. All samples consisted of half-split diamond drill core for a total footage of 462,991 ft. The samples covered an area from levels 21 to 45, for a vertical distance of 3,014 ft and a horizontal distance of 2,400 ft. Bancroft (1979) stated the average silver assay was 0.49 oz/t.

In 1965, drifting started in the shaft No. 8 area and was completed on levels 57 and 65 (depths of 7,000 ft and 8,000 ft).

In 1967, no new high-grade gold-bearing mineralization was identified between levels 57 and 65. It was decided to lay aside this part of the Horne 5 deposit. Mining of the gold-rich orebodies in the Horne 5 deposit continued from 1967 to 1976. Not much information is available for the years 1968 to 1976. It seems that work at the Horne mine during this period was limited to extracting the estimated remaining 2,776,000 st of ore from several orebodies in the Lower H and Horne 5 deposits (1968 estimate).

***Note: These “reserves” are historical in nature and should not be relied upon. It is unlikely they comply with current NI 43-101 criteria or CIM Standards and Definitions, and they have not been verified to determine their relevance or reliability. They are included in this section for illustrative purposes only and should not be disclosed out of context. InnovExplo did not review the database, key assumptions, parameters or methods used for this estimate.***

From 1967 to 1976, four stopes were mined in the Horne 5 deposit. Total production from these stopes added 221,864 st at 0.208 oz/t Au and 0.727% Cu (Bancroft, 1980; Table 6-2). The last muck hoisted at the Horne mine was on July 29, 1976 (Bancroft and Atkinson, 1987).

Table 6-2: Production from Horne 5 deposit  
 (Bancroft, 1980)

Gold Mined in No. 5 Zone from 1967 to 1976							
Depth (ft)	Level	Stope	Short tons mined	Au oz/t	Cu %	Oz Au	Short tons Cu
4,515	37-91	91K	8,994	0.22	0.23	1,979	2,069
5,015	41-90	90F	8,659	0.13	1.67	1,126	14,461
5,515	45-93	93X	79,577	0.26	0.16	20,690	12,732
6,015	49-94	94	124,634	0.18	1.06	22,434	132,112
<b>Total</b>			<b>221,864</b>	<b>0.208</b>	<b>0.727</b>	<b>46,229</b>	<b>161,374</b>

In 1980, Bancroft estimated the Horne 5 deposit contained a remaining 1,683,874 st of mineralization at grades of 0.179 oz/t Au (0.156 oz/t cut to 0.5 oz/t), 0.47% Cu and 0.48 oz/t Ag, based on previous evaluations of gold-rich zones and taking into account mining depletion (Bancroft, 1980).

***Note: These “reserves” and/or “resources” are historical in nature and should not be relied upon. It is unlikely they comply with current NI 43-101 criteria or CIM Standards and Definitions, and they have not been verified to determine their relevance or reliability. They are included in this section for illustrative purposes only and should not be disclosed out of context. InnovExplo did not review the database, key assumptions, parameters or methods used for this estimate.***

In February 1985, open pit and underground mining operations resumed at the Horne mine with the REMNOR project. REMNOR’s primary objective was to provide gold flux for the Horne smelter by mining blocks of the mineralized rhyolite adjacent to the sulphide bodies. REMNOR operations ceased in early August 1989 after producing approximately 604,000 tonnes averaging 5.8 g/t Au, including 118,000 tonnes of massive sulphide ore grading 7.2 g/t Au (Kerr and Mason, 1990). According to Kerr and Mason (1990), the remaining resources on the Concession at that time totalled 3.2 Mt at an average grade of 5.0 g/t Au and 0.45% Cu.

***Note: These “resources” are historical in nature and should not be relied upon. It is unlikely they comply with current NI 43-101 criteria or CIM Standards and Definitions, and they have not been verified to determine their relevance or reliability. They are included in this section for illustrative purposes only and should not be disclosed out of context. InnovExplo did not review the database, key assumptions, parameters or methods used for this estimate.***

## 6.2 Alexis Minerals Corporation Period (2011 - 2012)

From 2011 to 2012, Alexis Minerals did not conduct any exploration work on the Concession.

## 6.3 Falco Period (2012 - 2014)

In March 2013, Falco retained InnovExplo to complete a digital model of the Horne 5 deposit. The model incorporated 370 level plans, 620 cross sections, 99 longitudinal sections, over 4,300 drill holes and over 150,000 assay results. Modelling also included more than 55,000 m of Noranda's underground development on 22 levels and 18 sublevels that was carried out between 1931 and 1976 during the exploration of the Horne 5 deposit.

After completing the digital model, InnovExplo was retained to prepare an initial NI 43-101 compliant mineral resource estimate for the deposit and a supporting technical report (April 16, 2014: Brousseau et al., 2014). The estimate outlined an Inferred resource of 25.3 Mt grading 2.64 g/t Au, 0.23% Cu and 0.7% Zn for 2,152,800 oz of contained gold (Table 6-3) at a NSR cut-off of \$80.

**Table 6-3: 2014 Mineral resource estimate results (Inferred resources) at different NSR cut-offs (Brousseau et al., 2014)**

Cut-off (NSR \$/t)	Tonnes	AuEq. g/t	Au g/t	Cu %	Zn %	Contained Au eq.(oz)	Contained Au (oz)	Contained Cu (lbs)	Contained Zn (lbs)
>50	67,617,800	2.48	1.82	0.17	0.72	5,393,147	3,947,325	260,812,850	1,072,512,165
>60	50,363,800	2.75	2.05	0.19	0.73	4,456,722	3,319,349	213,666,254	814,194,416
>70	35,861,500	3.07	2.33	0.21	0.72	3,535,241	2,689,108	168,382,959	572,954,462
>80	25,319,200	3.41	2.64	0.23	0.70	2,772,723	2,152,796	131,053,584	393,085,645
>90	17,933,100	3.77	2.98	0.26	0.69	2,176,317	1,719,438	101,652,879	272,086,281
>100	12,835,200	4.17	3.35	0.28	0.67	1,720,963	1,381,887	78,910,482	189,885,650
>110	9,501,200	4.57	3.72	0.30	0.66	1,394,892	1,134,900	62,611,455	138,288,532

Notes:

- The Independent and QPs for the Mineral Resource Estimate, as defined by NI 43-101, are Karine Brousseau, Eng., and Carl Pelletier, B.Sc., P.Geo. (InnovExplo), and the effective date of the Estimate is February 17, 2014.
- These mineral resources are not mineral reserves as they do not have demonstrated economic viability.
- While the results are presented undiluted and in situ, the reported mineral resources are considered to have reasonable prospects for economic extraction.
- The estimate includes five high-grade gold-bearing zones and four low-grade gold-bearing envelopes.
- Resources were compiled at NSR cut-offs of: \$50, \$60, \$70, \$80, \$90, \$100, and \$110 per tonne. The official resource potential is reported at 80 \$/t cut-off.
- NSR cut-off parameters used: CAD/USD exchange rate = 1.05; Gold price = 1,300 USD/oz; Copper price = 3.30 USD/lb; Zinc price = 0.95 USD/lb; Payable metals = 87% for gold, 65% for copper and 37% for zinc.
- Cut-off will have to be re-evaluated in light of future prevailing market conditions (gold price, exchange rate and mining cost).
- Density values were calculated from drill hole iron assay data using a 3-pass ID<sup>2</sup> interpolation method for the ENV\_A and HG\_A to HG\_E zones. A fixed density of 2.88 g/cm<sup>3</sup>, representing the average of the available data, was used for ENV\_B to ENV\_D due to the scarcity of the data.
- The resource was estimated using Geovia GEMS 6.5. The estimate is based on 4,384 DDH (305,788 m). A minimum true thickness of 7.0 m was applied using the grade of the adjacent material when assayed, or a value of zero when not assayed.
- High grade capping (g/t Au) was done on raw assay data and established on a per zone basis (HG\_A: 35; HG\_B: 70; HG\_C: 25; HG\_D: 35; HG\_E: 25; ENV\_A: 70; ENV\_B: 25; ENV\_C: 25; ENV\_D: 25). No capping was applied to the Cu and Zn data.
- Compositing was done on drill hole sections falling within the mineralized zones (composite = 3.0 m).
- Resources were evaluated from drill holes using an ID<sup>2</sup> interpolation method in a block model (block size = 5 x 5 x 5 m).
- The Mineral Resources presented herein are categorized as Inferred.
- Ounce (troy) = metric tonnes x grade / 31.10348. Calculations used metric units (metres, tonnes and g/t). Metal contents are presented in ounces and pounds.
- The number of metric tonnes was rounded to the nearest hundred. Any discrepancies in the totals are due to rounding effects; rounding followed the recommendations in NI 43-101.
- The quantity and grade of reported Inferred resources in this Mineral Resource Estimate are uncertain in nature and there has been insufficient exploration to define these Inferred resources as Indicated or Measured, and it is uncertain if further exploration will result in upgrading them to these categories.
- CIM definitions and guidelines for mineral resources have been followed.
- InnovExplo is not aware of any known environmental, permitting, legal, title-related, taxation, socio-political or marketing issues, or any other relevant issue, that could materially affect the Mineral Resource Estimate.

In 2015, drilling in the Horne 5 deposit area comprised 2 phases. The first phase consisted of a confirmation drilling program targeting the Horne 5 deposit itself. The second phase consisted of an exploration drilling program known as “Horne 5 Plus”. The second phase tested targets identified by the 2014 compilation work, as well as mineralization intersected during the confirmation drilling program. Table 6-4 summarizes the statistics of the 17,300 m confirmation drilling program from the nine pilot holes were drilled from three different set-ups.

Table 6-4: Summary statistics of the confirmation drilling program

Hole	Azimuth	Dip	Final Depth (m)	Length Drilled (m)	Metallic Assays	Whole Rock Assays
H5-15-01	165	-59	1,269	1,269	739	51
H5-15-01-Atw	165	-59	1,196	207	239	1
H5-15-01-Btw	165	-59	1,206	161	204	1
H5-15-02	189	-63	1,209	1,209	549	48
H5-15-02-Atw	189	-63	1,919	1,008	759	18
H5-15-03	196	-71	475	475	71	15
H5-15-03-A	196	-71	1,161	761	196	19
H5-15-03-B	196	-71	1,467	379	305	14
H5-15-03-C <sup>(1)</sup>	196	-71	1,240	90	0	0
H5-15-03-Dtw	196	-71	1,486	352	323	0
H5-15-04	160	-62	1,396	1,396	641	55
H5-15-04-Atw	160	-62	1,331	191	176	2
H5-15-05	168	-78	1,992	1,992	1,289	76
H5-15-05-Atw	168	-78	1,853	152	148	0
H5-15-06	149	-60	1,353	1,353	565	40
H5-15-06-Atw	149	-60	1,329	163	197	2
H5-15-07	138	-67	1,128	1,128	606	36
H5-15-07-A	141	-67	2,035	1,229	810	50
H5-15-07-Btw	138	-67	2,006	116	125	0
H5-15-07Ab <sup>(1)</sup>	141	-64	200	200	0	0
H5-15-08	147	-66	1,593	1,593	845	55
H5-15-08-Atw	147	-66	1,606	208	257	1
H5-15-08Ab1 <sup>(1)</sup>	152	-67	75	75	2	0
H5-15-08Ab2 <sup>(1)</sup>	152	-67	62	62	0	0
H5-15-09	192	-67	1,085	1,085	492	35
H5-15-09-A	192	-67	1,291	297	316	9
H5-15-09-Btw	192	-67	1,291	153	193	0
<b>Total</b>				<b>17,300</b>	<b>10,047</b>	<b>528</b>

<sup>(1)</sup> Abandoned drill hole

Table 6-5 summarizes the drilling statistics of the Horne 5 Plus exploration drilling program totalling 8,000 m. The objective of the program was to test other targets in close proximity to the Horne 5 deposit.

Table 6-5: Summary statistics of the Horne 5 Plus program

Hole	Azimut	Dip	Final Depth (m)	Length Drilled (m)	Metallic Assays	Whole Rock Assays
H5-15-07-C	141	-67	1,769	1,108	794	42
H5-15-08-B	147	-66	747	378	338	11
H5-15-10	140	-46	1,171	1,171	293	41
H5-15-11	162	-46	772	772	413	21
H5-15-12	170	-71	936	936	540	29
H5-15-13	162	-50	881	881	444	29
H5-15-14	135	-47	648	648	325	19
H5-15-15	120	-43	1,072	1,072	306	29
H5-15-16	135	-55	1,024	1,024	296	25
<b>Total</b>				<b>8,000</b>	<b>3,749</b>	<b>246</b>

On January 25, 2016, Falco reported the results of an updated mineral resource estimate for the Horne 5 deposit (Jourdain et al., 2016) (the “March 2016 MRE”). The result of that study was a single resource estimate for four mineralized envelopes: ENV\_A, ENV\_B, ENV\_C and ENV\_D. The main mineralized envelope (ENV\_A) includes five high-grade gold zones, one high-grade copper-bearing zone, one high-grade zinc-bearing zone and two high-grade silver-bearing zones. This March 2016 MRE consisted of Indicated and Inferred resources for an underground volume.

The March 2016 MRE was made using 3D block modelling and the inverse distance square interpolation (ID<sup>2</sup>) method in a wireframe model of the Horne 5 deposit. The model has a strike-length of 800 m, a width ranging from 7 m to 120 m, and a vertical depth from 600 m to 2,600 m below surface.

The March 2016 MRE used 4,403 DDH totalling 323,087 m. It comprised 4,384 underground DDH, the accompanying gold, copper and zinc assay results obtained by conventional analytical methods, and specific gravity data. The underground drill holes covered the length of the Project at a fairly regular drill spacing of 15 m in a radiating (fan) pattern from 40 underground working levels and sublevels throughout the deposit. The database also contained the results of 19 DDH from the 2015 confirmation drilling program. A total of 160,884 samples were used. For silver, all available assays from both underground and surface drilling were used, as well as the results of an exhaustive metallurgical testing program comprising 2,112 DDH totalling 75,540 m, grouped into 54 lots assayed for silver.

---

The mineral resources were estimated using different NSR cut-offs and a minimum width of 7.0 m (true width). The selected NSR cut-off of 65 \$/t allowed the mineral potential of the deposit to be outlined for an underground mining option.

The results of the March 2016 MRE at the base case NSR cut-off of \$65 are presented in Table 6-6.

The March 2016 MRE statement for the Horne 5 deposit reported an Indicated resource of 58,346,300 tonnes at 2.86 g/t AuEq (gold equivalent) for a total of 5,361,400 oz AuEq, and an Inferred resource of 12,678,700 tonnes at 3.08 g/t AuEq for a total of 1,254,200 oz AuEq.



**Table 6-6: March 2016 Mineral Resource Estimate for the Horne 5 deposit at \$65 NSR cut-off (Jourdain et al., 2016)**

Resource Category	Tonnes (Mt)	AuEq (g/t)	Au (g/t)	Ag (g/t)	Cu (%)	Zn (%)	Contained AuEq (Moz)	Contained Au (Moz)	Contained Ag (Moz)	Contained Cu (Mlbs)	Contained Zn (Mlbs)
Indicated	58.3	2.86	1.82	15.60	0.20	1.00	5.361	3.418	29.273	260.400	1248.800
Inferred	12.7	3.08	2.10	26.26	0.22	0.57	1.254	0.855	10.705	61.700	158.100

- The Independent and QPs for the Mineral Resource Estimate, as defined by NI 43-101, is Carl Pelletier, P.Geo., B.Sc., (InnovExplo Inc.), and the effective date of the Estimate is January 8, 2016.
- These mineral resources are not mineral reserves as they do not have demonstrated economic viability.
- While the results are presented undiluted and in situ, the reported mineral resources are considered to have reasonable prospects for economic extraction.
- The estimate includes four low-grade gold envelopes.
- The main low-grade gold zone contains five high-grade gold zones, one high-grade copper-bearing zone, one high grade zinc-bearing zone and two high-grade silver-bearing zones
- Resources were compiled at NSR cut-offs of: \$50, \$55, \$60, \$65, \$70, \$75, \$80, \$85, \$90, \$95, and \$100 per tonne. The official resource potential is reported at 65 \$/t cut-off.
- NSR cut-off parameters used: exchange rate = 1.27 CAD:1.00 USD; Gold price= 1,165 USD/oz; Silver price= 15.77 USD/oz; Copper price = 2.53 USD/lb; Zinc price = 0.89 USD/lb; Net Payable= 84.0% for gold, 75.3% for silver, 66.5% for copper and 71.8% for zinc. Smelting cost (including transportation) 7.73 \$/t.
- Cut-off will have to be re-evaluated in light of future prevailing market conditions (metal prices, exchange rate and mining cost).
- Density values were calculated from historical drill hole iron assay data and Falco density data using a 3-pass ID<sup>2</sup> interpolation method for the ENV\_A and HG\_A to HG\_E zones. A fixed density of 2.88 g/cm<sup>3</sup>, representing the median of the available data, was used for ENV\_B to ENV\_D due to the scarcity of the data.
- The resource was estimated using Geovia GEMS 6.7. The estimate is based on 4,411 DDH (323,087 m). For silver the estimates also uses the results of an exhaustive metallurgical test comprising 2,112 DDH assayed for silver over a total length of 75,540 m. A minimum true thickness of 7.0 m was applied, using the grade of the adjacent material when assayed, or a value of zero when not assayed. Only the silver interpolation in the Inferred resources does not use the material when not assayed.
- High grade capping was done on raw assay data and established on a per zone basis for gold (Au g/t): (HG\_A: 35; HG\_B: 35; HG\_C: 25; HG\_D: 35; HG\_E: 25; ENV\_A: 35; ENV\_B: 25; ENV\_C: 25; ENV\_D: 25) and for silver (Ag g/t): SG\_HG:100; HG\_D: 165; ENV\_A\_SG\_Low: 110; ENV\_B: 100; ENV\_C: 100; ENV\_D: 100. No capping was applied to the Cu and Zn data. Capping grade selection is supported by statistical analysis.
- Compositing was done on drill hole sections falling within the mineralized zones (composite = 3.0 m).
- Resources were evaluated from drill holes using an ID<sup>2</sup> interpolation method in a block model (block size = 5 x 5 x 5 m).
- The Mineral Resources presented herein are categorized as Indicated and Inferred based on drill spacing, geological and grade continuity. A maximum distance to the closest composite of 25 m was used for Indicated resources. The average distance to the nearest composite is 8.3 m for the Indicated resources and 35.2 m for the Inferred resources.
- Ounce (troy) = metric tonnes x grade / 31.10348. Calculations used metric units (metres, tonnes and g/t). Metal contents are presented in ounces and pounds.
- The number of metric tonnes was rounded to the nearest hundred. Any discrepancies in the totals are due to rounding effects; rounding followed the recommendations in NI 43-101.
- The quantity and grade of reported Inferred resources in this Mineral Resource Estimate are uncertain in nature and there has been insufficient exploration to define these Inferred resources as Indicated or Measured, and it is uncertain if further exploration will result in upgrading them to these categories.
- CIM definitions and guidelines for mineral resources have been followed.
- InnovExplo is not aware of any known environmental, permitting, legal, title-related, taxation, socio-political or marketing issues, or any other relevant issue, that could materially affect the Mineral Resource Estimate.

On November 7, 2016, Falco reported the results of an updated mineral resource estimate for the Horne 5 deposit (the “November 2016 MRE”). This updated resource estimate integrated a newly compiled historical underground channel sample database, new economic parameters (including a lower NSR cut-off), additional 2016 drilling results and revised commodity pricing assumptions. The resource model for the Horne 5 deposit was updated, and resources in the Measured category were reported for the first time on the Horne 5 Project. The Preliminary Economic Assessment prepared by BBA, dated June 23, 2016 (Hardie et al., 2016) (the “2016 PEA”), was not updated in light of the November 2016 MRE for the Horne 5 deposit.

The GEMS diamond drill hole database contains 11,023 DDH. This October 2017 MRE used 5,977 holes in the database (totalling 478,281 m; 220,478 samples), with the remaining holes being too far from the deposit to be of use for the estimation. Of this total, 5,938 are historical underground DDH. The database also includes the results of 31 DDH from the 2015–2016 confirmation drilling program that intersect the Horne 5 deposit. Another 8 DDH drilled close to the Horne 5 deposit during the 2015–2016 exploration program have also been included.

The November 2016 MRE was reported at a lower NSR cut-off than that used for the March 2016 MRE. This new NSR cut-off was supported by economic assumptions defined in the 2016 PEA. The November 2016 MRE also used an updated NSR calculation supported by new assumptions concerning metal prices, net recoveries and smelting cost.

Channel samples were compiled and digitized from the available Noranda historical plans in local grid mine and were documented for 23 of the 24 historically developed levels in the Horne 5 deposit. The vast majority of the samples were assayed for gold and copper, whereas zinc assays were more scarce and silver was only assayed sparsely at depth between levels 43 and 65. Over the 14,799 compiled and digitized channel samples, 8,915 are associated with mineralized zones. Channel sample data was only used for distance to composite criterion for Measured resource classification purposes.

The results of the November 2016 MRE is presented in Table 6-7.

Table 6-7: November 2016 Mineral Resource Estimate for the Horne 5 deposit at \$55 NSR cut-off

Resource Class	Cut-off (NSR C\$)	Tonnes	Au Equivalent g/t	Au g/t	Ag g/t	Cu %	Zn %	Contained Au EQ (oz)	Contained Au (oz)	Contained Ag (oz)	Contained Cu (lbs)	Contained Zn (lbs)
Measured	> 40	11 644 000	2.21	1.42	15.46	0.17	0.73	826 724	530 386	5 789 209	42 781 845	186 158 376
	> 45	10 884 200	2.28	1.47	15.74	0.17	0.75	799 426	513 969	5 506 283	41 196 031	180 655 296
	> 50	10 118 600	2.36	1.52	16.01	0.18	0.78	769 098	495 643	5 207 294	39 505 764	174 219 296
	> 55	9 361 800	2.45	1.58	16.33	0.18	0.81	736 421	475 410	4 914 349	37 672 449	167 402 703
	> 60	8 643 600	2.53	1.64	16.61	0.19	0.84	702 779	454 619	4 616 673	35 830 796	160 164 077
	> 65	7 885 500	2.62	1.70	16.90	0.19	0.87	664 414	431 243	4 285 355	33 782 384	151 210 238
	> 70	7 193 300	2.71	1.77	17.19	0.20	0.90	626 788	408 525	3 975 881	31 729 326	141 970 341
	> 75	6 477 100	2.81	1.84	17.48	0.21	0.92	585 217	383 485	3 639 181	29 410 622	131 694 520
	> 80	5 818 100	2.91	1.92	17.66	0.21	0.95	544 499	359 144	3 303 540	27 225 652	121 309 845
	> 85	5 202 300	3.01	2.00	17.77	0.22	0.96	504 118	335 148	2 972 444	25 141 955	110 615 281
	> 90	4 642 000	3.12	2.09	17.86	0.23	0.98	465 393	311 854	2 665 172	23 105 264	100 619 066
	> 95	4 100 200	3.23	2.18	17.99	0.23	1.00	426 047	287 638	2 371 119	21 144 745	90 605 672
> 100	3 623 700	3.34	2.28	18.08	0.24	1.02	389 705	265 219	2 106 521	19 317 452	81 329 166	

Resource Class	Cut-off (NSR C\$)	Tonnes	Au Equivalent g/t	Au g/t	Ag g/t	Cu %	Zn %	Contained Au EQ (oz)	Contained Au (oz)	Contained Ag (oz)	Contained Cu (lbs)	Contained Zn (lbs)
Indicated	> 40	101 193 300	2.18	1.40	13.28	0.16	0.78	7 106 718	4 561 707	43 216 888	361 222 169	1 732 373 996
	> 45	94 776 600	2.26	1.45	13.58	0.17	0.80	6 876 282	4 420 159	41 389 265	347 023 865	1 681 157 217
	> 50	88 312 700	2.33	1.50	13.88	0.17	0.83	6 620 430	4 263 292	39 423 671	331 909 656	1 621 335 082
	> 55	81 735 100	2.41	1.56	14.19	0.18	0.86	6 335 860	4 088 383	37 294 859	315 830 464	1 552 729 386
	> 60	75 030 900	2.50	1.61	14.53	0.18	0.89	6 021 298	3 893 721	35 042 172	298 866 949	1 475 006 823
	> 65	68 278 500	2.59	1.68	14.89	0.19	0.92	5 679 408	3 683 116	32 678 965	280 681 708	1 387 152 589
	> 70	61 663 700	2.68	1.75	15.24	0.19	0.95	5 319 676	3 463 531	30 211 981	261 810 565	1 291 174 091
	> 75	55 291 800	2.78	1.82	15.58	0.20	0.97	4 949 134	3 239 298	27 699 476	243 001 702	1 187 893 122
	> 80	49 387 700	2.89	1.90	15.88	0.21	0.99	4 583 663	3 020 056	25 211 029	224 864 386	1 082 826 423
	> 85	43 777 200	3.00	1.99	16.14	0.21	1.01	4 215 803	2 798 579	22 721 918	207 141 824	976 681 962
	> 90	38 485 300	3.11	2.08	16.37	0.22	1.03	3 849 377	2 577 589	20 255 648	189 790 010	870 545 575
	> 95	33 608 500	3.23	2.19	16.61	0.23	1.04	3 494 073	2 361 472	17 947 645	173 002 348	768 394 721
> 100	29 224 100	3.36	2.30	16.79	0.24	1.04	3 158 288	2 158 014	15 772 309	157 207 719	670 572 051	

Resource Class	Cut-off (NSR C\$)	Tonnes	Au Equivalent g/t	Au g/t	Ag g/t	Cu %	Zn %	Contained Au EQ (oz)	Contained Au (oz)	Contained Ag (oz)	Contained Cu (lbs)	Contained Zn (lbs)
Measured + Indicated	> 40	112 837 300	2.25	1.40	13.51	0.16	0.77	8 150 983	5 092 093	49 006 097	404 004 013	1 918 532 372
	> 45	105 660 800	2.32	1.45	13.80	0.17	0.80	7 884 749	4 934 128	46 895 548	388 219 896	1 861 812 513
	> 50	98 431 300	2.40	1.50	14.10	0.17	0.83	7 589 521	4 758 936	44 630 965	371 415 421	1 795 554 378
	> 55	91 096 800	2.48	1.56	14.41	0.18	0.86	7 262 628	4 563 793	42 209 208	353 502 913	1 720 132 089
	> 60	83 674 500	2.57	1.62	14.74	0.18	0.89	6 904 300	4 348 340	39 658 845	334 697 744	1 635 170 900
	> 65	76 164 000	2.66	1.68	15.10	0.19	0.92	6 513 148	4 114 360	36 964 321	314 464 092	1 538 362 827
	> 70	68 857 000	2.76	1.75	15.44	0.19	0.94	6 104 524	3 872 056	34 187 862	293 539 891	1 433 144 432
	> 75	61 768 900	2.86	1.82	15.78	0.20	0.97	5 681 035	3 622 782	31 338 658	272 412 325	1 319 587 642
	> 80	55 205 800	2.97	1.90	16.07	0.21	0.99	5 263 903	3 379 201	28 514 569	252 090 038	1 204 136 268
	> 85	48 979 500	3.08	1.99	16.32	0.22	1.01	4 844 997	3 133 727	25 694 362	232 283 780	1 087 297 243
	> 90	43 127 300	3.19	2.08	16.53	0.22	1.02	4 429 406	2 889 443	22 920 820	212 895 273	971 164 640
	> 95	37 708 700	3.32	2.19	16.76	0.23	1.03	4 024 661	2 649 110	20 318 763	194 147 093	859 000 393
> 100	32 847 800	3.45	2.29	16.93	0.24	1.04	3 643 045	2 423 233	17 878 830	176 525 171	751 901 217	

Resource Class	Cut-off (NSR C\$)	Tonnes	Au Equivalent g/t	Au g/t	Ag g/t	Cu %	Zn %	Contained Au EQ (oz)	Contained Au (oz)	Contained Ag (oz)	Contained Cu (lbs)	Contained Zn (lbs)
Inferred	> 40	29 982 700	2.09	1.27	20.20	0.18	0.62	2 018 313	1 225 760	19 474 995	121 579 421	408 634 980
	> 45	27 554 500	2.18	1.33	21.03	0.19	0.64	1 930 449	1 176 117	18 634 351	114 786 950	389 104 374
	> 50	24 940 000	2.28	1.39	21.98	0.20	0.66	1 826 129	1 116 815	17 622 512	107 406 534	365 167 423
	> 55	22 283 200	2.39	1.47	22.98	0.20	0.68	1 709 903	1 053 061	16 463 471	99 171 805	336 101 668
	> 60	20 058 400	2.49	1.54	23.94	0.21	0.70	1 604 364	995 491	15 437 436	91 439 498	309 347 419
	> 65	17 472 900	2.62	1.64	25.21	0.21	0.72	1 472 118	922 946	14 159 498	80 661 116	278 551 219
	> 70	15 293 600	2.75	1.74	26.48	0.21	0.74	1 352 929	856 634	13 019 250	71 823 610	249 906 179
	> 75	13 406 500	2.88	1.84	27.70	0.22	0.75	1 242 754	794 507	11 940 661	64 601 999	222 924 808
	> 80	11 528 900	3.04	1.96	29.10	0.23	0.77	1 126 481	727 514	10 784 724	57 409 881	195 709 438
	> 85	9 821 100	3.21	2.11	30.25	0.23	0.78	1 014 193	664 774	9 552 769	50 654 094	168 612 199
	> 90	8 222 900	3.41	2.29	30.98	0.25	0.77	902 745	604 603	8 189 164	44 700 861	139 977 418
	> 95	6 927 000	3.63	2.48	31.57	0.26	0.76	807 733	552 850	7 030 524	39 678 474	115 974 677
> 100	5 912 700	3.84	2.68	32.15	0.27	0.74	729 657	509 966	6 112 206	35 554 367	96 081 089	

**Resource Estimate Notes:**

1. The effective date of the resource estimate is September 26, 2016. The Independent and QPs for the Mineral Resource Estimate as required by National Instrument 43-101 are Carl Pelletier, P. Geo., B.Sc. and Guilhem Servelle, P.Geo., M.Sc., both employees of InnovExplo.
2. Mineral Resources are not Mineral Reserves and do not have demonstrated economic viability.
3. While the results are presented undiluted and in situ, the reported mineral resources are considered by the QPs to have reasonable prospects for economic extraction.
4. These estimates include six low-grade gold-bearing mineralized envelopes.
5. The main low-grade gold-bearing mineralized envelope includes six high-grade gold-bearing zones, one high-grade copper-bearing zone, one high grade zinc-bearing zone and three high-grade silver-bearing zones. Note that these high-grade zones may overlap each other.
6. Resources were compiled at NSR cut-offs of: \$40, \$45, \$50, \$55, \$60, \$65, \$70, \$75, \$80, \$85, \$90, \$95 and \$100 per tonne for sensitivity purposes.
7. The official base case resource is reported at a 55 \$/t NSR cut-off.
8. The appropriate NSR cut-off will vary depending on prevailing economic and operational parameters to be determined.
9. NSR estimates are based on the following assumptions: Exchange rate of 1.30 CAD / 1.00 USD; Metal prices as follows: gold 1,300 USD/oz, silver 18.50 USD, copper 2.15 USD/lb, zinc 1.00 USD/lb (inspired from a long-term analyst consensus price forecast study); Net recoveries of 86.8% for gold, 74.9% for silver, 67.3% for zinc, and 74.0% for copper. Smelting cost (including transportation) of 6.52 \$/t (based on the cost mine service, as well as a non-public smelter contract obtained from one of the proposed destinations and talks with transport providers).
10. Gold equivalent calculations assume these same metal prices.
11. Inferred resources are separate from Indicated resources.
12. The quantity and grade of reported Inferred resources are uncertain in nature and there has not been sufficient work to define these Inferred resources as Indicated or Measured resources. It is uncertain if further work will result in upgrading them to an Indicated or Measured mineral resource category.
13. The resource was estimated using Geovia GEMS 6.7. The estimate is based on 5,977 DDH (478,281 m) of which 4,138 cut mineralized zones for a total of 177,996 m of core within these zones. For silver, the estimate also uses the results of an exhaustive metallurgical test comprising 2,112 DDH assayed for silver over a total length of 75,540 m. A minimum true thickness of 7.0 m was applied, using the grade of the adjacent material when assayed, or a value of zero when not assayed. Only the silver interpolation in the Inferred resources does not use the material when not assayed.
14. The estimate database also contains 14,799 channel samples for a total of 23,791 m from historically sampled drifts. Channel sample data was only used for distance to composite criterion for resource classification purposes.
15. 91% of density values were estimated using historical iron assay drill hole data and Falco density data for an average of 3.41 g/cm<sup>3</sup>. The interpolation method uses three passes for the ENV\_A and HG\_A to HG\_F zones. 8% of the density values were fixed at 2.88 g/cm<sup>3</sup> for ENV\_B to ENV\_E due to the scarcity of the data. 2.88 g/cm<sup>3</sup> represents the median of the available data. 1% of density values were fixed at 2.67 g/cm<sup>3</sup> for ENV\_F due to the scarcity of the data and to adequately characterize this quartz-rich zone.
16. Compositing was done on drill hole sections falling within the mineralized zones (composite = 3.0 m). Tails shorter than 0.75 m were not generated.
17. Resources were evaluated from drill holes using an ID<sub>2</sub> interpolation method in a block model (block size = 5 x 5 x 5 m).
18. High-grade capping was done on raw assay data and established on a per zone basis for gold (Au g/t): (HG\_A: 35; HG\_B: 35; HG\_C: 25; HG\_D: 35; HG\_E: 25; HG\_F: 35; ENV\_A: 35; ENV\_B: 25; ENV\_C: 25; ENV\_D: 20; ENV\_E: 35; ENV\_F: 25) and for silver (Ag g/t): (SG\_HG:100; HG\_D: 165; HG\_F: 165; ENV\_A\_SG\_Low: 110; ENV\_B: 100; ENV\_C: 100; ENV\_D: 100. Capping grade selection is supported by statistical analysis. No capping was applied to the Cu and Zn data based on statistical analysis.
19. The reported Mineral Resources are categorized as Measured, Indicated and Inferred. The Inferred category is only defined within the areas where blocks were interpolated during pass 1 or pass 2 in areas where continuity is sufficient to avoid isolated blocks. The Indicated category is only defined by blocks interpolated in areas where the maximum distance to the closest drill hole composite is less than 25 m for blocks interpolated in passes 1 and 2. The Measured category is only defined by blocks classified as Indicated and within sufficient proximity to sampled drifts (<15 m). The average distance to the nearest composite is 6.97 m for the Measured resources, 10.01 m for the Indicated resources and 40.10 m for the Inferred resources.
20. Tonnage estimates were rounded to the nearest hundred tonnes. Any discrepancies in the totals are due to rounding effects. Rounding practice follows the recommendations set forth in Form 43-101F1.
21. CIM definitions and guidelines were followed in estimating mineral resources.
22. InnovExplo is not aware of any known environmental, permitting, legal, title-related, taxation, socio-political, marketing or other relevant issue that could materially affect the mineral resource estimate.
23. Metal contained in ounces (troy) = metric tonnes x grade / 31.10348. Calculations used metric units (metres, tonnes and g/t). Metal contents are presented in ounces and pounds.

## 6.4 Preliminary Economic Assessment Summary (2016)

On May 9, 2016, Falco reported the results of the 2016 PEA. The present section offers a summary of this study.

### 6.4.1 Mining Methods

The proposed underground mine design supports the extraction of 15,000 tpd by transverse long-hole stopping with primary and secondary stopes. This mining method is suitable given the geometry, ground conditions and depth of the resources.

The Quemont No. 2 shaft will be rehabilitated to accommodate a production rate of 15,000 tpd and provide the principal access to the deposit.

***As previously indicated, the Quemont No. 2 shaft is owned by the Third Party and located on Concession 243 also held by the Third Party. Falco must obtain one or more licenses from the Third Party, which may not be unreasonably withheld, but which may be subject to conditions that the Third Party may require in its sole discretion. These conditions may include the provision of a performance bond or other assurance to the Third Party and the indemnification of the Third Party by Falco. The agreement with the Third Party stipulates, among other things, that the license shall be subject to reasonable conditions which may include, among other things, that activities at Horne 5 will be subordinated to the current use of the surface lands and subject to priority, as established in such party's sole discretion, over such activities. Any license may provide for, among other things, access to and the right to use the infrastructure owned by the Third Party.***

#### 6.4.1.1 Mine Production Plan

The ramp-up period to full production will require five years from the onset of mine development, including the dewatering and rehabilitation sequence.

Full production at 15,000 tpd will begin during Q4 2020 and continue to 2030, for a total of 10 years. Production then drops to 12,658 tpd in 2031 and to 6,840 tpd in 2032 upon depletion of mine Phases 2 and 3. The breakdown is as follows:

- Phase 1 will run from 2020 to 2028;
- Phase 2 will run from 2025 to 2032;
- Phase 3 will run from 2029 to 2032.

A total of 63,751,000 tonnes of mineralized material will be hoisted during this period, at a grade of 1.63 g/t Au, 0.19% Cu, 0.85% Zn and 15.52 g/t Ag.

#### 6.4.2 Capital and Operating Costs

The total capital costs (preproduction and sustaining) of the Horne 5 Project was estimated at \$1,334.6M. The preproduction costs were calculated at \$905.2M including a \$60.0M contingency. The sustaining costs were calculated at \$429.4M including \$51.6M required for site restoration.

The average operating cost over the 12-year mine life was estimated to be 47.45 \$/t. No contingency had been included within the operating cost estimate.

It was anticipated that a total facility workforce of 554 employees would be required on site.

#### 6.4.3 Interpretation and Conclusions

The results of the 2016 PEA indicated that the proposed Horne 5 Project had technical and financial merit using the base case assumptions. The results were considered sufficiently reliable to guide Falco's management in a decision to advance the Project to a feasibility study.

#### 6.4.4 Recommendations

It was recommended that the Horne 5 Project proceed to the FS stage in line with Falco's desire to advance the Project. It was also recommended that environmental work and permitting continue as needed to support Falco's development plans.

It was estimated that a feasibility study, laboratory studies and supporting fieldwork would cost approximately \$10.0M.

## 7. GEOLOGICAL SETTING AND MINERALIZATION

### 7.1 Regional Geology

#### 7.1.1 Abitibi Terrane (Abitibi Sub-province)

The Abitibi Greenstone Belt has been historically subdivided into northern and southern volcanic zones defined using stratigraphic and structural criteria (Dimroth et al., 1982; Ludden et al., 1986; Chown et al., 1992) and mainly based on an allochthonous greenstone belt model development; i.e. interpreting the belt as a collage of unrelated fragments. The first geochronological constrained stratigraphic and/or lithotectonic map (Figure 7-1), interpreted by Thurston et al. (2008), includes the entire Abitibi Greenstone Belt known coverage span, i.e. from the western Kapuskasing Structural Zone to the eastern Grenville Province. Thurston et al. (2008) described the Abitibi Greenstone Belt to be mainly composed of volcanic units, which were unconformably overlain by large sedimentary Timiskaming-style assemblages. Similarly, both new mapping surveys and new geochronological data indicate an autochthonous origin for the Abitibi Greenstone Belt.

Generally, the Abitibi Greenstone Belt comprises east-trending synclines containing volcanic rocks and intervening domes cored by synvolcanic and/or syntectonic plutonic rocks (gabbro-diorite, tonalite, and granite) alternating with east-trending turbiditic wacke bands (MERQ-OGS, 1984; Ayer et al., 2002a; Daigneault et al., 2004; Goutier and Melançon, 2007). Normally, the volcanic and sedimentary strata dip vertically and are usually separated by abrupt, variably dipping east-trending faults. Some of these faults, such as the Porcupine-Destor Fault, display evidence of overprinting deformation events including early thrusting, later strike-slip and extension events (Goutier, 1997; Benn and Peschler, 2005; Bateman et al., 2008). Two ages of unconformable successor basins are observed: a) widely distributed fine-grained clastic rocks in early Porcupine-style basins, followed by b) Timiskaming-style basins composed of coarser clastic sediments and minor volcanic rocks, largely proximal to major strike-slip faults, such as the Porcupine-Destor and Larder Lake-Cadillac faults and other similar regional faults in the northern Abitibi Greenstone Belt (Ayer et al., 2002a; Goutier and Melançon, 2007). The Abitibi Greenstone Belt is intruded by numerous late-tectonic plutons composed mainly of syenite, gabbro and granite with fewer lamprophyre and carbonatite dikes. Commonly, the metamorphic grade in the Abitibi Greenstone Belt varies from the greenschist to sub-greenschist facies (Jolly, 1978; Powell et al., 1993; Dimroth et al., 1983b; Benn et al., 1994) except in the vicinity of most plutons where the metamorphic grade corresponds mainly to the amphibolite facies (Jolly, 1978).



## 7.1.2 New Abitibi Greenstone Belt Subdivisions

As mentioned in Section 7.1.1, the most recent data from the newest mapping surveys and new geochronological information by the Ontario Geological Survey and Géologie Québec, were used to define the new Abitibi Greenstone Belt subdivisions. The following section presents a more detailed description of these new subdivisions mostly abridged from Thurston et al. (2008) and references therein.

Seven discrete volcanic stratigraphic episodes define the new Abitibi Greenstone Belt subdivisions based on numerous U-Pb zircon age groupings. The new U-Pb zircon ages clearly show timing similarities for volcanic episodes and plutonic activity ages between the northern and southern portions of the Abitibi Greenstone Belt, as indicated in Figure 7-1. These seven volcanic episodes (Figure 7-1) are listed below, chronologically from the oldest to the youngest:

- Volcanic episode 1 (pre-2750 Ma);
- Pacaud Assemblage (2750–2735 Ma);
- Deloro Assemblage (2734–2724 Ma);
- Stoughton-Roquemaure Assemblage (2723–2720 Ma);
- Kidd-Munro Assemblage (2719–2711 Ma);
- Tisdale Assemblage (2710–2704 Ma);
- Blake River Assemblage (2704–2695 Ma).

The Abitibi Greenstone Belt successor basins are of two types: a) laterally extensive basins corresponding to the Porcupine Assemblage with early turbidite-dominated units (Ayer et al., 2002a), followed by b) the aeri ally more restricted alluvial-fluvial or Timiskaming-style basins (Thurston and Chivers, 1990).

The geographic limit (Figure 7-1) between the northern and southern parts of the Abitibi Greenstone Belt has no tectonic significance but is similar to the limits between the internal and external zones of Dimroth et al. (1982) and those between the Central Granite-Gneiss and the Southern Volcanic zones of Ludden et al. (1986). The boundary between the northern and southern parts passes south of the wackes of the Chicobi and Scapa groups with a maximum depositional age of 2698.8 ~ 2.4 Ma (Ayer et al., 1998, 2002b).

The Abitibi Sub-province is bounded to the south by the Larder Lake–Cadillac Fault Zone, a major crustal structure that separates the Abitibi and Pontiac sub-provinces (Chown et al., 1992; Mueller et al., 1996; Daigneault et al., 2002, Thurston et al., 2008).

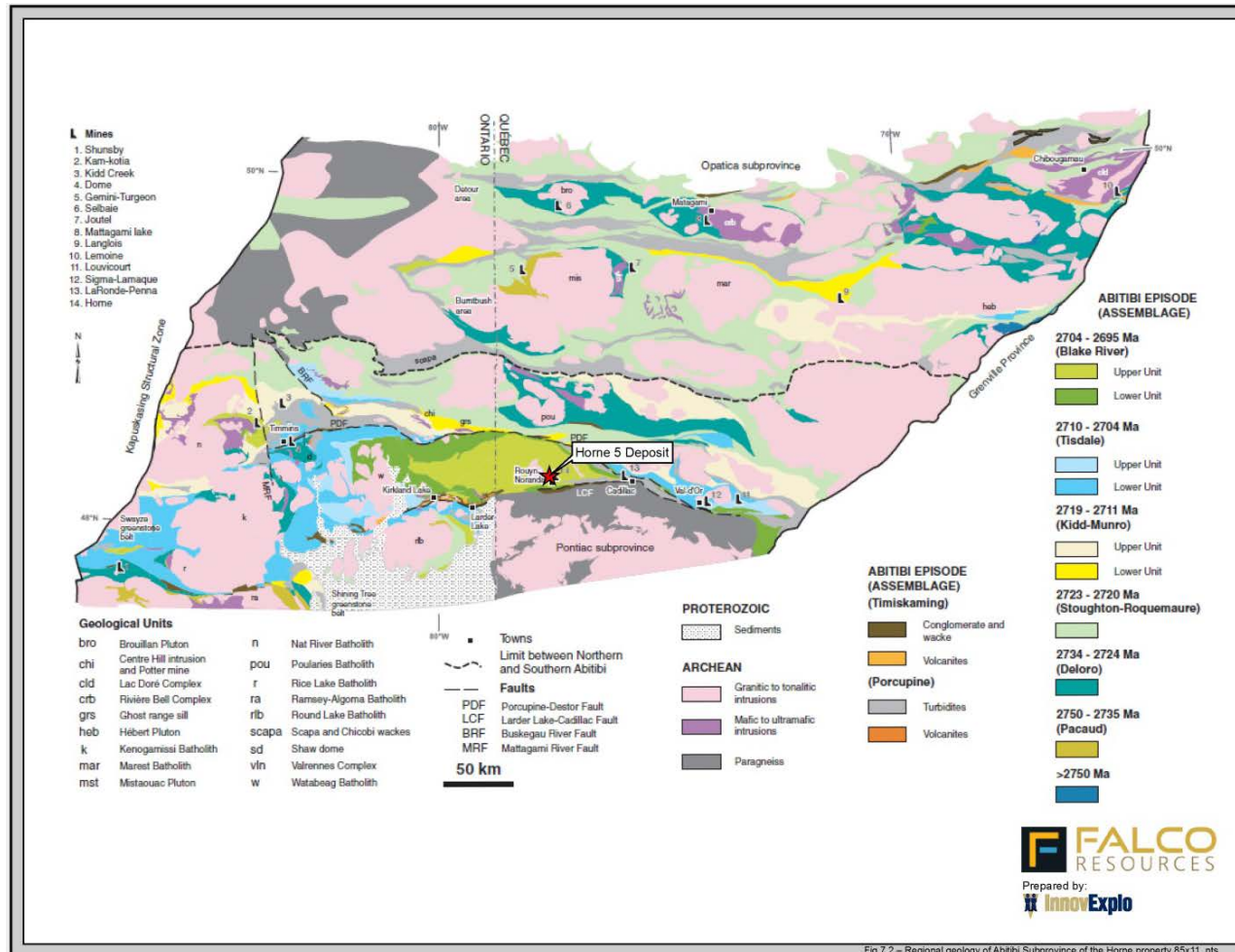

Figure 7-1: Stratigraphic map of the Abitibi Greenstone Belt  
 The geology of the southern Abitibi Greenstone Belt is based on Ayer et al. (2005) and the Québec portion on Goutier and Melançon (2007).  
 Modified from Thurston et al. (2008).

### 7.1.3 Noranda Camp

There have been numerous studies carried out on the Noranda camp (or Rouyn-Noranda camp), and the Horne deposit in particular, most notably including: Spence and de Rosen-Spence (1975); Dimroth et al., (1982; 1983a); Kerr and Mason (1990); Barrett and MacLean (1991); Barrett et al. (1991); MacLean and Hoy (1991); Cattalini et al. (1993); Kerr and Gibson (1993); and Gibson and Galley (2007). Recent studies by Monecke et al. (2008) and Mercier-Langevin et al. (2011) summarized the salient aspects of the geology of the Noranda camp and provided a synopsis of previously known and new geologic information on the Horne Block. In particular, Monecke et al. (2008) and Laurin (2010) presented a modern description of the coherent and volcanoclastic rocks comprising a portion of the footwall section in the “Horne West” area, an area that was briefly the focus of renewed exploration. Moreover, de Kemp et al. (2011) and Taylor et al. (2014) mapped the architecture of the Horne volcanogenic massive sulphide (VMS) deposit hydrothermal systems in a 3D visualization.

The following description of the geological setting of the Noranda camp is summarized from Monecke et al. (2008), except where noted.

The Noranda Camp or Noranda Volcanic Complex (“NVC”) represents one of the largest volcanic centres within the Blake River Group (Figure 7-1). This centre has an approximate diameter of 35 km and is composed of 7.5 km to 9 km of bimodal volcanic strata of predominantly tholeiitic to mildly transitional affinity comprising numerous alternating mafic and felsic units crosscut by synvolcanic dikes of dioritic and gabbroic composition (Gélinas et al., 1984; Gibson and Watkinson, 1990; Péroquin et al., 1990; Kerr and Gibson, 1993).

Following the work of Spence and de Rosen-Spence (1975), Gibson (1990) subdivided the volcanic succession of the NVC into five cycles of volcanism, each cycle consisting of lower basaltic and andesitic units overlain by intercalated mafic and felsic upper units (Figure 7-2). Volcanism of the NVC took place over a comparably short time span from ca. 2700 Ma to 2696 Ma (Mortensen, 1993b; Lafrance et al., 2005; David et al., 2006).

The volcanic stratigraphy of the NVC is intruded by the synvolcanic Flavrian and Powell plutons. The Flavrian Pluton is composed of sill-like intrusions that are characterized by shallow dips to the east and generally conformable contacts with the overlying volcanic strata (Wilson, 1941). Geochemical and petrographic evidence suggests that the Powell Pluton, located south of the Beauchastel Fault (Figure 7-2), represents a faulted equivalent to the Flavrian Pluton (Spence and de Rosen-Spence, 1975; Goldie, 1978).

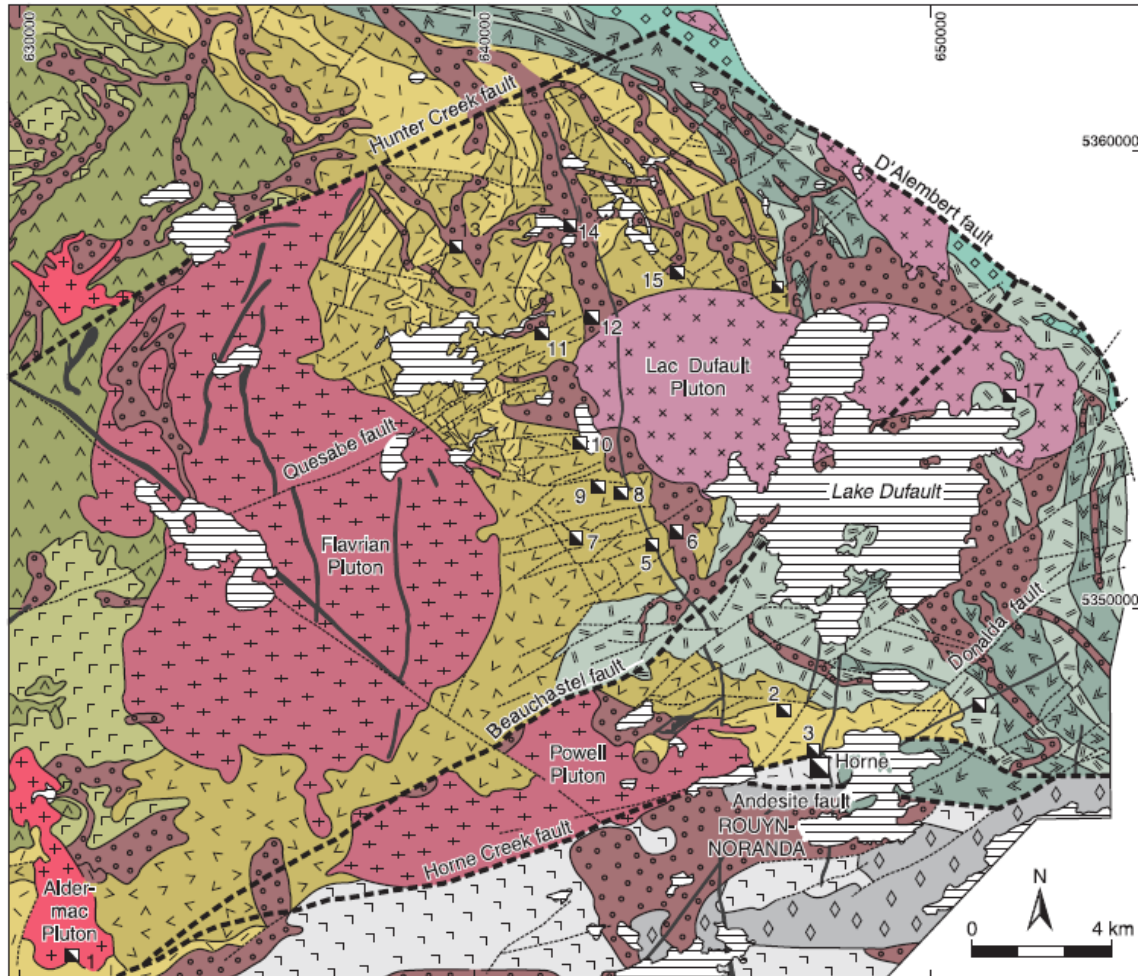

Volcanic-hosted massive sulphide deposits: 1 = Aldermac, 2 = Joliet, 3 = Quemont, 4 = Delbridge, 5 = D68, 6 = Millenbach, 7 = Corbet, 8 = Amulet A, 9 = Amulet C, 10 = Amulet F, 11 = Old Waite, 12 = East Waite, 13 = Ansil, 14 = Vauze, 15 = Norbec, 16 = Newbec, and 17 = Gallen

Archean extrusive rocks		Archean intrusive rocks		Proterozoic intrusive rocks	
Undifferentiated	Cycle 3				
□ □ □	▨	++	Rhyolite	▨	Diabase
▨	< ▨	xx	Basalt, andesite	---	Major fault
◇ ◇	Cycle 4	++		---	Minor fault
	▨ ▨	++	Rhyolite	▣	Deposit
Cycle 1+2	▨ ▨	oo	Basalt, andesite		
▨ ▨ ▨	Cycle 5				
▨ ▨ ▨	▨ ▨		Rhyolite		
▨ ▨ ▨	▨ ▨		Basalt, andesite		
▨ ▨ ▨	▨ ▨		Basalt, andesite		

Figure 7-2: Generalized geologic map of the Noranda mining camp, showing major structural elements and the distribution of extrusive and intrusive rocks (From Monecke et al., 2008). The locations of VMS deposits are shown (modified from Santaguida, 1999). The coordinates are UTM (NAD83, Zone 17).

The NVC has been subdivided into a number of structural blocks that are delimited by major faults and their extrapolations (Spence, 1976; Peloquin et al., 1990). Lithological correlation between the different structural blocks has proven difficult in most cases. The area north of the Hunter Creek Fault is referred to as the Hunter Block. The areas between the Hunter Creek and Beauchastel faults, and between the Beauchastel and Horne Creek faults, are respectively referred to as the Flavrian Block and the Powell Block. The Horne Block lies between the Horne Creek Fault and the Andesite Fault (Figure 7-2 and Figure 7-3).

## 7.2 Property Geology

### 7.2.1 Central Mine Sequence

Previous research largely focused on the Flavrian and Powell blocks in the central part of the NVC, where most of the known massive sulphide deposits occur. The volcanic stratigraphy in both blocks, collectively referred to as the “Central Mine Sequence”, shows similarities and is correlative across the Beauchastel Fault (Gibson et al., 1984). The Central Mine Sequence is dominated by coherent basalt, andesite, and rhyolite that are intercalated with lesser amounts (<5%) of volcanoclastic deposits. Mafic volcanic rocks form predominantly pillowed and massive flows, whereas the rhyolite units were typically emplaced as tabular flows and low-relief domes (Spence and de Rosen-Spence, 1975; Kerr and Gibson, 1993). Volcanism of the Central Mine Sequence occurred in a below-storm-wave-base, presumably in a deep, marine environment; however, local shoaling has been postulated for strata in the Powell area, which occurs at the southern limit of the Central Mine Sequence (Lichtblau and Dimroth, 1980).

The volcanic units within the Central Mine Sequence strike north to northeast, are gently folded about east-trending and east-plunging axes, and dip from 5°E to 55°E (Spence and de Rosen-Spence, 1975; Gibson and Watkinson, 1990). They are interpreted to have been deposited within a volcano-tectonic subsidence structure, which is referred to as the Noranda Cauldron or Noranda Caldera (Dimroth et al., 1982; Gibson, 1990; Gibson and Watkinson, 1990; Kerr and Gibson, 1993). Recently, Pearson (2005), Daigneault and Pearson (2006), and Pearson and Daigneault (2006) proposed that the Noranda Caldera may be superimposed on two larger and older calderas, the New Senator Caldera, which encompasses the NVC, and an older caldera, the Misema Caldera, which encloses the entire Blake River Group.



## 7.2.2 Horne Block Sequence

The Horne Block Sequence consists of volcanic rocks that form part of the Horne Block. The volcanic stratigraphy within the mine area faces to the north, strikes approximately west-northwest, and dips steeply to the north (Wilson, 1941; Hodge, 1967; Sinclair, 1971; Kerr and Mason, 1990; Kerr and Gibson, 1993; Gibson et al., 2000; Monecke et al., 2008). The bounding Horne Creek and Andesite faults converge approximately 2.2 km to the west of the Horne deposit and dip steeply toward one another (Figure 7-2 and Figure 7-3).

The dominantly felsic volcanic succession hosting the Horne deposit consists of coherent rhyolite and related volcanoclastic deposits, interpreted to represent subaqueous lava flows with lesser synvolcanic intrusions, redeposited syn-eruptive volcanoclastic deposits, and possible primary pyroclastic deposits (Kerr and Mason, 1990; Kerr and Gibson, 1993; Gibson et al., 2000; Monecke et al., 2008). Kerr and Gibson (1993) informally divided the volcanic host rocks of the Horne deposit into three conformable formations that, from stratigraphic footwall to hanging wall, include the West 3919, Main Mine, and REMNOR formations (Figure 7-4 and Figure 7-5).

Due to the lack of detailed surface mapping, the sense and magnitude of displacement along the bounding faults is uncertain. Underground exposure in the Horne and Quemont mines revealed that the Horne Creek and Andesite faults are composite and show evidence of repeated movement (Wilson, 1941). Within the mine area, the zone of intense shearing along the Horne Creek Fault varies from about 50 m to 150 m in thickness. The Andesite Fault has been interpreted to be a subsidiary of the Horne Creek Fault (Hodge, 1967) and the zone of intense shearing along this fault ranges from less than 1 m to 10 m wide (Wilson, 1941); however, considerable structural complications within the mine area are caused by a northeast-trending set of curvi-planar splays off the Andesite Fault that slice the volcanic succession and the mineralization into a number of smaller blocks (Gibson et al., 2000).

Attempts to stratigraphically or geochronologically correlate the host-rock succession of the Horne deposit with volcanic units outside the Horne Block, especially those belonging to the Central Mine Sequence have been largely unsuccessful (Peloquin et al., 1990; Gibson et al., 2000). Immediately on the north side of the Horne Creek Fault lies the Quemont massive-sulphide deposit that is hosted by rhyolite breccia and porphyritic coherent rhyolite (Ryznar et al., 1967; Weeks, 1967). Volcanic rocks showing similar textural characteristics have not been recognized within the Horne Block; however, intrusive rocks similar to those of the Powell Pluton outcropping farther to the west along the northern side of the Horne Creek Fault have been encountered during deep drilling at the western tip of the Horne Block (Kerr and Mason, 1990).

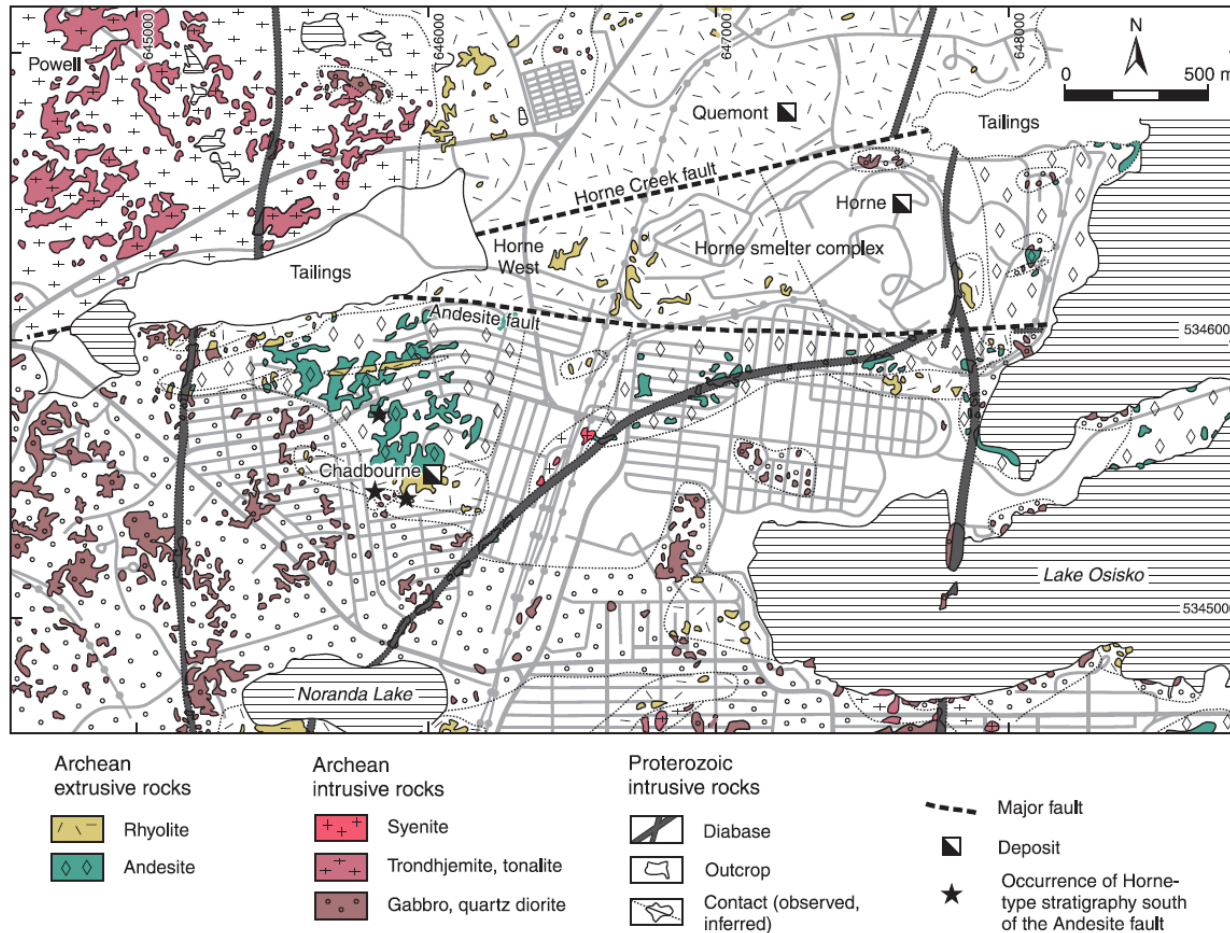

Figure 7-3: Geology of the Horne Block and surrounding areas  
 (From Monecke et al., 2008; modified from Wilson, 1941)

Also indicated are occurrences of Horne-type stratigraphy observed south of the Andesite Fault. Coordinates on the map are UTM (NAD83, Zone 17).

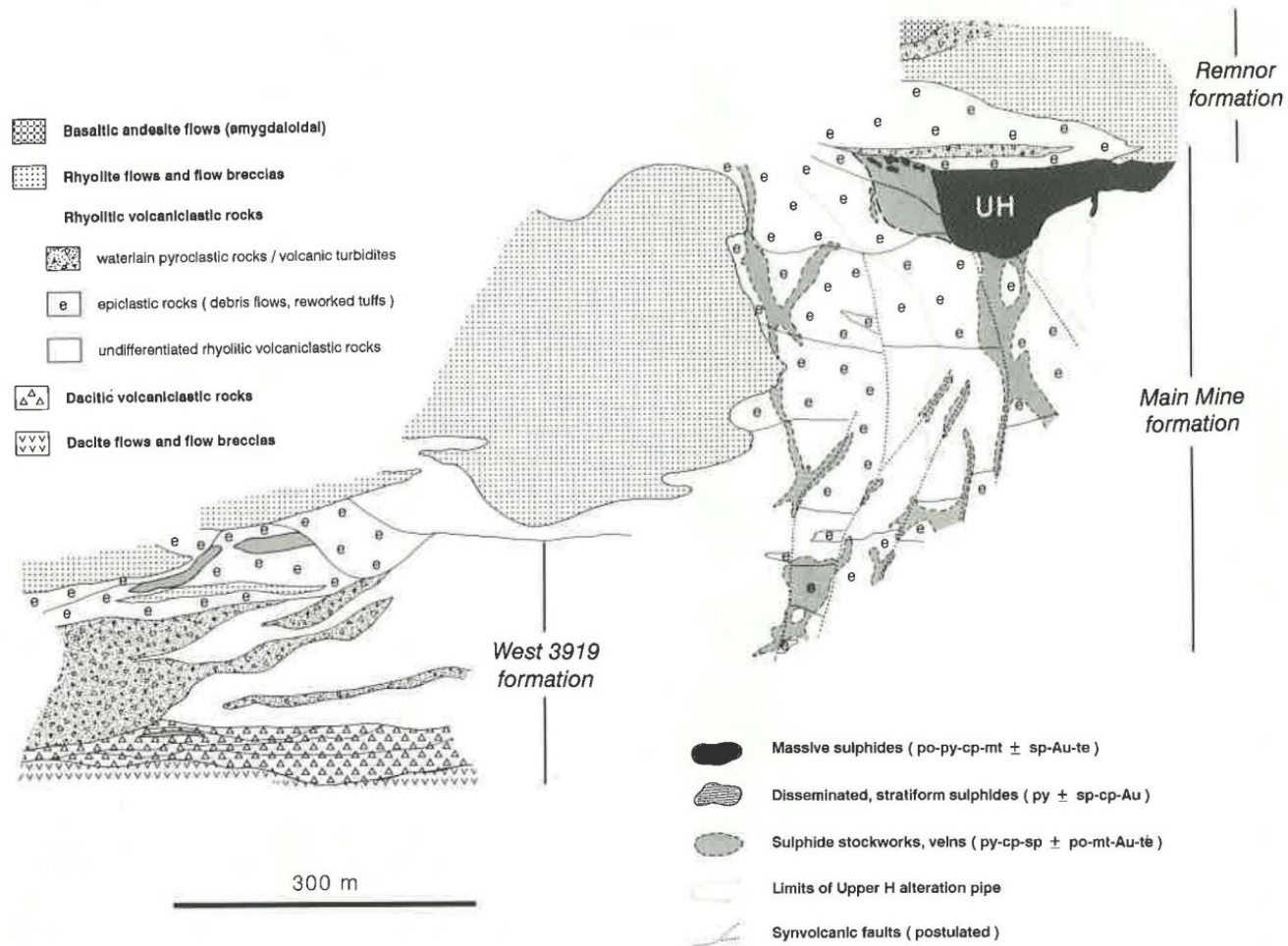

Figure 7-4: Volcanic reconstruction of the Horne sequence, with informal subdivisions, based on the geology of the 975 ft level (Modified from Kerr and Mason, 1990; Kerr and Gibson, 1993). UH = Upper H massive sulphide body.



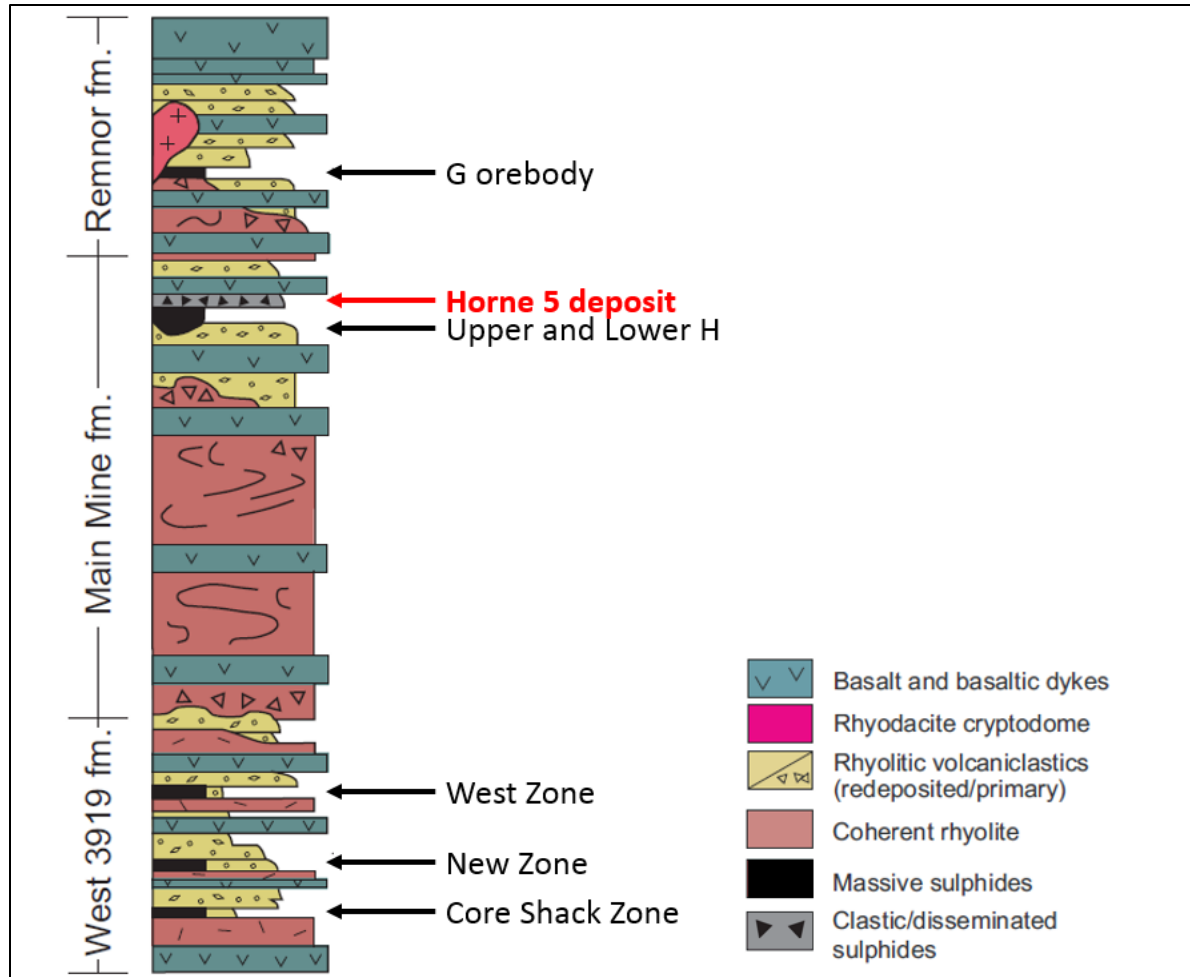

Figure 7-5: Simplified stratigraphic section through the Horne 5 deposit (Modified from Gibson et al., 2000; Mercier-Langevin et al., 2011).

Rocks south of the Andesite Fault are mainly andesitic to basaltic in composition (Figure 7-3), strike approximately east, but also show a sub-vertical dip. Initial fieldwork carried out as a part of the present study indicates that felsic volcanoclastic rocks containing sulphide clasts and with textural characteristics similar to volcanic deposits within the Horne Block occur south of the Andesite Fault, in the Chadbourne area (Figure 7-3).

Geological relationships at the eastern limit of the Horne succession are poorly constrained at present. Historical mine-level plans indicate that the felsic volcanic rocks are in contact with a wedge-shaped package of mafic rocks located to the northeast. This package of mafic rocks appears to thicken toward the east, separating the orebodies from the Horne Creek Fault. The contact between the felsic volcanic rocks hosting the orebodies and the package of mafic rocks parallels bedding and strikes approximately west-northwest, suggesting a conformable contact relationship, which would imply that the mafic rocks were emplaced as either flows or sills; however, the wedge-shaped package of mafic rocks has previously been interpreted to be entirely intrusive (Price, 1934). In addition to this package of mafic rocks, Wilson (1941) noted the occurrence of extrusive andesite along the western shore of Lake Osisko. The distribution of surface outcrops in this area defined a north-striking contact relationship between the package of felsic volcanic rocks hosting the Horne deposit and the Lake Osisko andesite (Figure 7-3), indicating an angular discordance (possible unconformity) between these units.

### West 3919 Formation

The following description of the geological setting of the West 3919 Formation is summarized from Kerr and Gibson (1993).

The West 3919 Formation, which constitutes the base of the sequence, was deposited during a period of explosive rhyolitic and dacitic volcanism and high energy sedimentation. The formation consists of two geochemically distinct members, the Coreshack and Powerline members, separated by an unconformity that is, in part, erosional, (Figure 7-4 and Figure 7-5).

The dacitic Coreshack Member includes, from bottom to top: 1) silicified dacitic flows and hyaloclastites; 2) thin cherty units, interbedded with laminated pyrite-sphalerite-gold mineralization of the Coreshack Zone; 3) polymictic, phreatomagmatic, normally-graded breccias and; 4) poorly sorted, crudely graded, lapilli- to ash-sized debris flows dominated by subrounded rhyolitic clasts (0.5–2 cm in diameter), but also containing other exotic fragments. Subeconomic Au-Cu mineralization (the New Zone; Figure 7-5) is associated with disseminated pyrite and pyrite-chlorite-sericite-(chalcopyrite-sphalerite) veinlets and sericite-quartz alteration within the dacitic debris flows.

The Powerline Member of the West 3919 Formation is rhyolitic in composition and can be subdivided into a basal volcanoclastic unit and an upper epiclastic unit. The lower part is composed of lithic-vitric lapilli tuffs deposited in upward-fining cycles. The overlying epiclastic unit includes well-bedded pyritic turbidites, a quartz-porphyrific rhyolitic flow with flank and carapace breccias containing decimeter-scale blocks of massive pyrite, and plane-bedded, lapilli- to ash-sized reworked tuffs. Gold mineralization of the West Zone is associated with disseminated sulphides within the reworked tuffs.

### Main Mine Formation

The following description of the geological setting of the Main Mine Formation is summarized from Kerr and Gibson (1993).

The Main Mine Formation (Figure 7-4 and Figure 7-5) is composed of volcanism dominated by rhyolite flow and low-energy sedimentation shown by proximal, massive to poorly bedded, compositionally homogenous tuff breccias. The H orebodies and the Horne 5 deposit lie within fragmental rocks of the Main Mine Formation. A large volume of aphyric to sparsely feldspar-porphyrific lobe-hyaloclastite flows erupted from a vent complex west of the H orebodies (Figure 7-5). Unconsolidated rhyolitic debris was shed east from this vent complex into an adjacent, linear topographic depression and formed a thick breccia pile composed principally of proximal, massive to poorly bedded, compositionally homogenous tuff breccias (flank or talus breccias) and finer grained subaqueous granular mass flow deposits (reworked tuffs) interbedded with water-lain lithic-crystal tuffs. These rhyolitic flows and associated volcanoclastic rocks constitute the 1340 Member of the Main Mine Formation. Some flow tongues or lobes extend east from the vent complex into the trough-fill breccias. On upper mine levels, other flow lobes have been observed to thicken toward the east and may represent coulees that erupted from a second rhyolitic vent complex east of the Upper H orebody. On lower mine levels, flows from this eastern vent complex constitute the immediate southeast footwall to the Lower H orebody.

The overlying Five Shaft Member of the Main Mine Formation includes lapilli tuffs and tuff breccias that are more polymictic, locally containing up to 5% quartz porphyritic pumice fragments (max diameter <5 cm) and clasts of massive pyrite (diameter <10 cm). These units can show well-preserved sedimentary structures such as plane-parallel bedding and scour channels and are believed to be the deposits of high-concentration turbidity currents and grain-dominant debris flows. The contact between the 1340 and Five Shaft members is gradational and the Upper and Lower H orebodies straddle this ill-defined contact. The Horne 5 deposit occurs near the base of the Five Shaft Member.

## REMNOR Formation

The following description of the geological setting of the REMNOR Formation is summarized from Kerr and Gibson (1993), except where noted.

The uppermost segment of the Horne sequence, the REMNOR Formation (Figure 7-4 and Figure 7-5), is characterized by initial passive rhyolitic flow volcanism and subsequent minor phreatomagmatic eruptions and debris flows. In terms of eruptive style, the REMNOR Formation is more akin to the intracauldron Central Mine sequence than is either the West 3919 or Main Mine formations.

The Icestope Member of the REMNOR Formation comprises a series of rhyolitic lobe-hyaloclastite flows, sparsely quartz-feldspar porphyritic, which erupted from a vent somewhere east of the H orebodies. A significant volcano-sedimentary hiatus following flow eruption permitted a small (<1 Mt) volcanogenic pyrite mound known as the G orebody to develop on the flank of the uppermost flow (Figure 7-6). REMNOR mining operations largely exploited ore associated with the G ore-body. Like the Central Mine sequence deposits, the G orebody is zoned from a central, massive pyrite ~ chalcopyrite-sphalerite-pyrrhotite spine to a thinly bedded pyrite-sphalerite fringe, and the lens is underlain by a zoned discordant alteration pipe characterized by a Fe-chlorite core and sericitic margins. Unlike the Mine sequence deposits, however, nearly all the ore associated with the G hydrothermal system came from Au-rich pyrite-sericite veins and phreatic pebble breccia dikes in the underlying alteration pipe rather than from the massive sulphide lens itself (Kerr and Mason, 1990).

The G orebody is overlain by a thin (<25 m), laterally extensive package of rhyodacitic volcanoclastic units which comprise the 56 Sill Member. The basal unit, 1 m to 5 m thick, is composed of extremely siliceous plane-bedded ash tuff (very similar to bedded tuffs of the Mine sequence) which is interbedded with poorly sorted crystal-lithic lapilli tuffs. Ultimately, the 56 Sill Member is conformably overlain by an amygdaloidal basaltic andesite flow that might have heralded the cessation of Horne sequence felsic volcanism and the onset a new volcanic cycle.

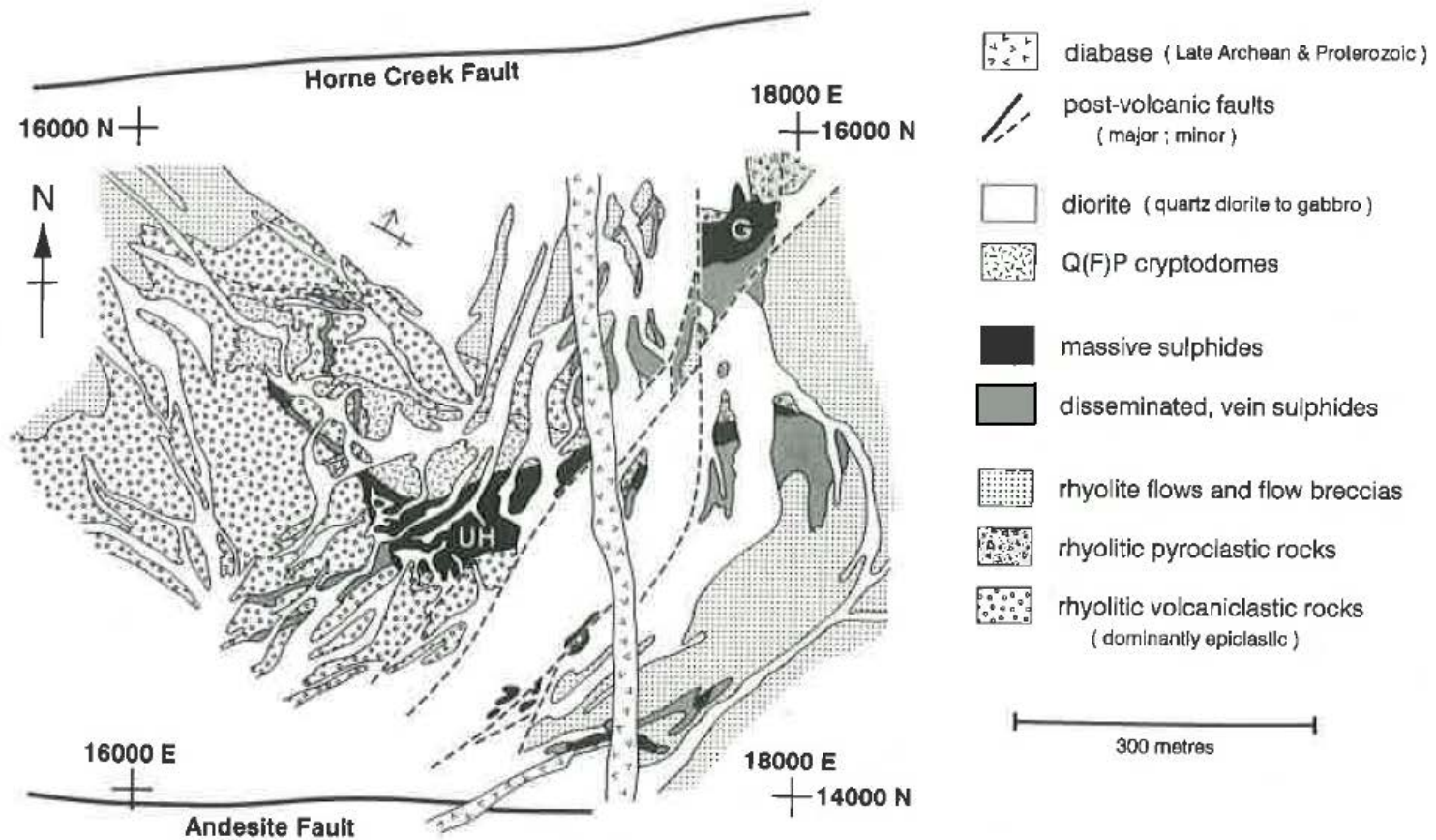

Figure 7-6: Geology of the 200-ft level at the Horne mine showing the Upper H and G orebodies  
 (Modified from Price, 1933 and 1949, in Kerr and Gibson, 1993)

## 7.3 Mineralization

The following description is summarized from Barrett et al. (1991) and Monecke et al. (2008), except where noted.

The Horne Mine orebodies (Upper H, Lower H and Horne 5 deposit) dip sub-vertically within rhyolitic flows, breccias, and tuffs that are bounded by the Andesite and the Horne Creek faults. Least-altered rhyolites have low K<sub>2</sub>O contents and other geochemical features that place them within the FII tholeiitic series (Leshner et al., 1986). Graded volcanoclastic beds, metal zoning in the orebodies, and locations of chloritized-mineralized rhyolites indicate that the volcanic sequence youngs to the north. The volcanics in the fault wedge are variably silicified and sericitized, and local zones in the orebody sidewalls and footwall are chloritized.

### 7.3.1 Upper and Lower H Orebodies

The H orebodies formed podiform masses up to 120 m wide, 100 m thick, and 300 m in down-plunge extent, consisting of chalcopyrite-pyrrhotite-pyrite gold ore (Figure 7-7 and Figure 7-8). Between 1927 and 1976, 54 Mt of ore were recovered, grading 2.2% Cu, 6.1 g/t Au, and 13.0 g/t Ag (Zn and Pb grades were <0.1% and <0.01%, respectively).

A semi-continuous Cu-rich base (up to 15 m thick) exists above the footwall and adjacent to the sidewalls of the orebodies. The ore changes stratigraphically upwards from a chalcopyrite-rich base, through middle pyrrhotite-pyrite-rich zones, to upper pyrite-rich zones. Gold enrichments occur in some of the Cu-rich ores but also in overlying pyritic ores and in adjacent host volcanics. Cu-Au-bearing chloritized rhyolites occur mainly in the western and eastern sidewalls and at down-plunge terminations of the H orebodies.

### 7.3.2 Horne 5 Deposit

The Lower H orebody is stratigraphically overlain by a massive to semi-massive sulphide body, referred to as the Horne 5 deposit (Sinclair, 1971). This tabular zone consists of numerous lenses of massive pyrite interbedded with intensely altered felsic volcanoclastic rocks. The Horne 5 deposit (Figure 7-7 and Figure 7-8) extends for a strike length of more than 1,000 m to a depth of at least 2,650 m and ranges from approximately 30 m to 140 m in thickness (Sinclair, 1971; Fisher, 1974; Gibson et al., 2000).



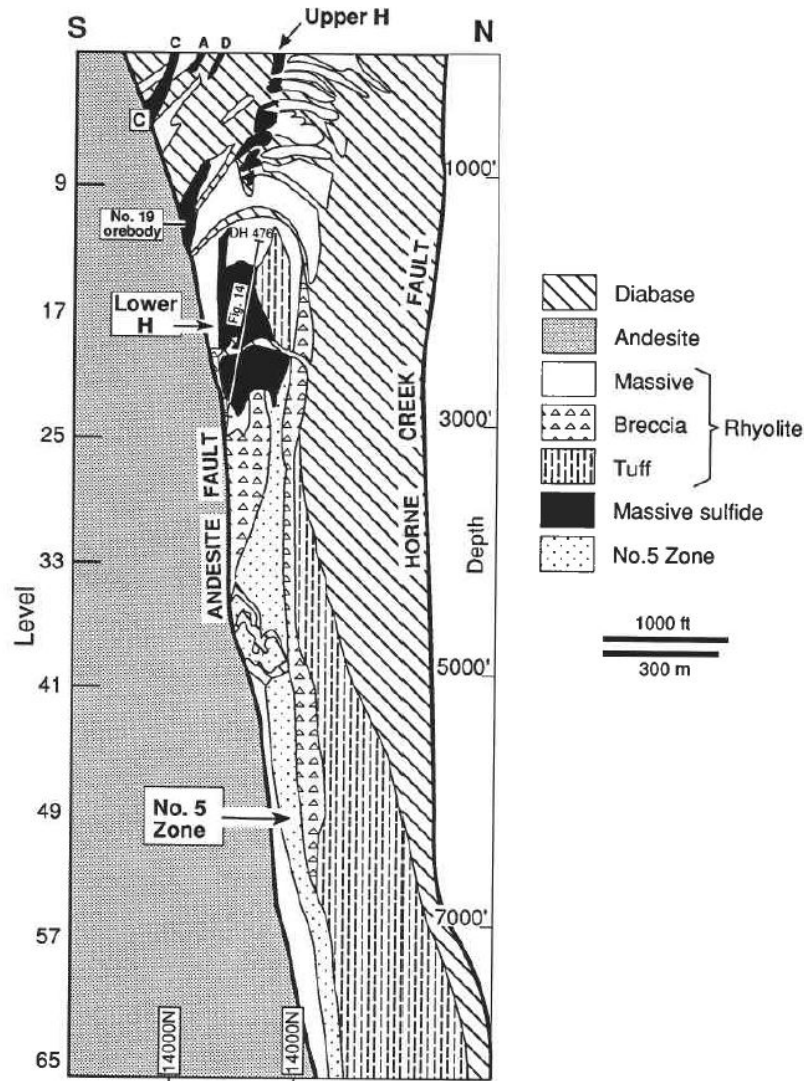

Figure 7-7: Simplified vertical cross section through the Horne 5 mine (section 50 East, looking west) (From Barrett et al., 1991)

The section shows the locations of the Upper and Lower H orebodies and the Horne 5 deposit in the fault-bounded wedge between the Andesite Fault and Horne Creek Fault. Host stratigraphy, where it is undeformed and not affected by diabase intrusions, dips sub-vertically and youngs to the north. Smaller massive sulphide lenses (A, C, D) also occurred to the south of the Upper H orebody, the largest of which was the No. 19 orebody. The G orebody lay to the north of the Upper H orebody. Mine level numbers are shown on the left side, and level depths on the right side. (After Bancroft and Atkinson, 1987)

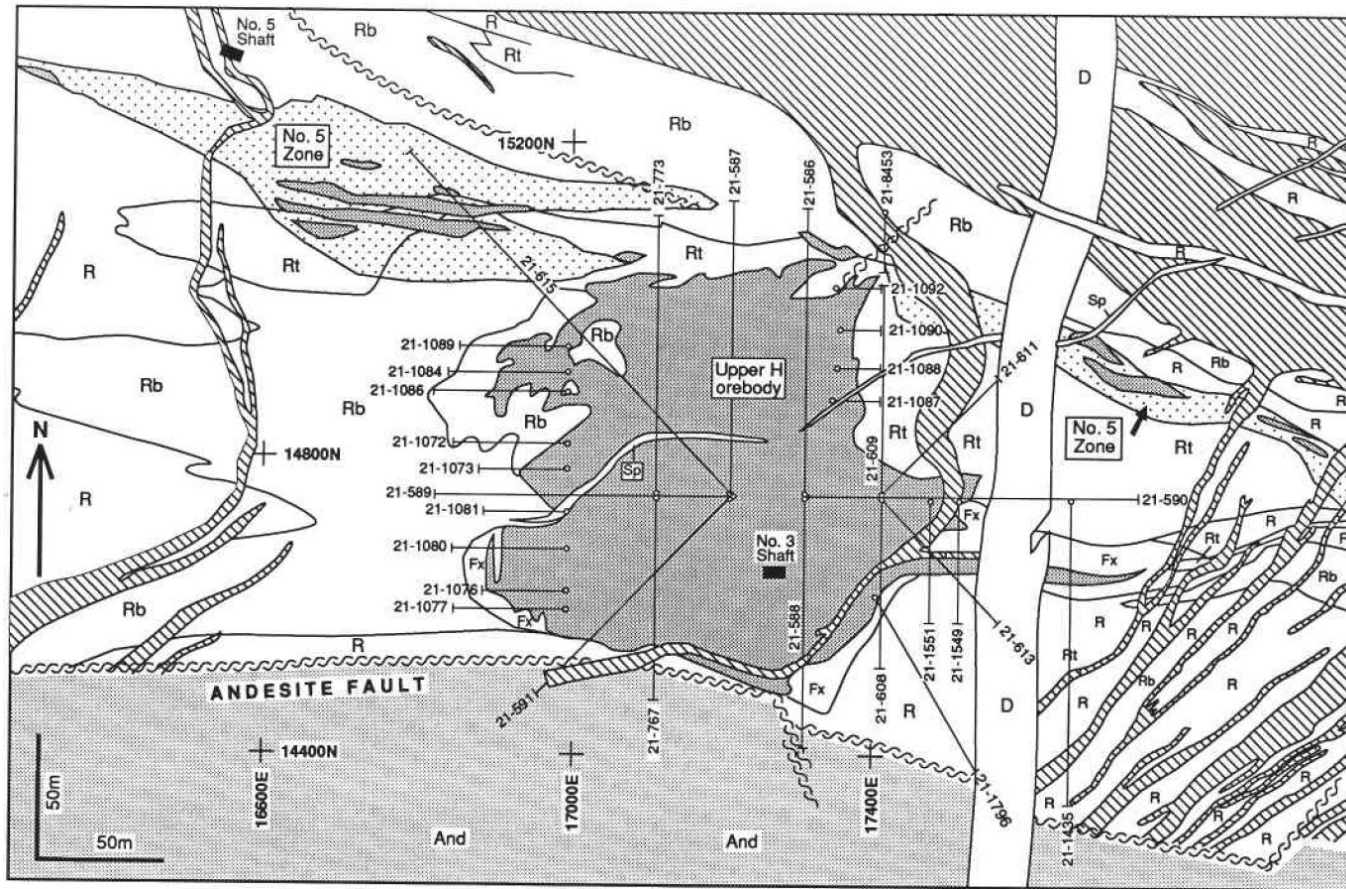

Figure 7-8: Geology of level 21 of the Horne 5 deposit, based on unpublished maps of Noranda Mines Ltd. At this level, the Horne 5 deposit mineralization (light stipple) occurs as a semi-continuous lenticular zone extending from northwest to southeast across the stratigraphic top of the Lower H orebody; massive pyritic lenses are shaded. See legend on Figure 7-7. (From Barrett et al., 1991).



Pyrite is the predominant sulphide in this zone, but scattered portions contain sphalerite, chalcopyrite, and gold in economic concentrations (Sinclair, 1971). Sphalerite is the second most abundant sulphide in the Horne 5 deposit, although it is virtually absent in the Lower H, but it is far less abundant than pyrite. Chalcopyrite is a common mineral in many parts of the Horne 5 deposit but usually is present in only very minor amounts. Pyrrhotite is even less abundant than chalcopyrite and galena is rare in the Horne 5 deposit. A set of drill-core samples of massive sulphides have been analyzed for copper, gold, zinc, and silver by Barrett et al., (1991). Based on 25 samples (13 samples from level 27 and 12 samples from level 49), the Horne 5 deposit contains, on average, 0.12% Cu, 1.8% Zn, 1.4 g/t Au, and 26.6 g/t Ag.

The restored stratigraphic level of the H orebodies and the Horne 5 deposit, as shown in Figure 7-9, is dominated from south to north by rhyolite flows and breccias, then rhyolite breccias and tuffs. The volcanic rocks are interpreted as proximal to distal facies on a volcanic edifice that was affected by widespread silicification and sericitization. A graben system on the flank of the edifice became the depositional site of the H orebodies. High-temperature fluid discharge occurred along the fault-bounded graben margins, producing zones of chloritization and stringer-type copper mineralization ~ gold in rhyolites, and infilling the grabens with Cu-bearing massive sulphides. Lower on the edifice, in the Horne 5 deposit, Zn-bearing pyritic sulphide lenses accumulated within broader, breccia-based depressions roughly on strike with the H orebodies. Mineralization in the Horne 5 deposit may reflect lower-temperature and more diffuse fluid discharge through a permeable sequence of volcanoclastic rocks.

The Horne 5 deposit extends from above level 21 down to below level 65. It attains significant thickness and breadth only below level 23 (the deepest extent of the Lower H orebody shown on Figure 7-11). Below level 23, the Horne 5 deposit ranges from 15 m to 125 m thick (Fisher 1970; Sinclair 1971).

In the plan view on level 27 (Figure 7-10 and Figure 7-11), the Horne 5 deposit forms a cigar-shaped zone ~500 m long and 30-60 m thick, consisting of about eight massive pyritic lenses with intervening rhyolite breccias containing disseminated pyrite. On level 49, the Horne 5 deposit is at least 750 m wide, with a thickness of up to 100 m. It contains about ten main pyritic lenses, the largest of which are ~60 m wide and ~5-25 m thick. A transect on level 49 shows two zones of mineralization separated by ~35 m of rhyolite (Figure 7-12). The lower zone is disseminated sulphides, whereas the upper zone consists of 10 m of massive sulphides that pass upwards into disseminated mineralization. On level 65, the mineralization is mainly disseminated (Figure 7-12). In a transect on level 27 (Figure 7-13a), zinc rises to ~5% towards the centre of the main pyritic lens. Gold is generally low (<3.4 g/t) throughout. On level 41, the highest copper contents occur in the lower 6 m and upper 10 m of the sulphide lens and the flanking mineralized tuffs (Figure 7-13b). Zinc values are low, and gold is generally low (<3.4 g/t) throughout. Contouring of analyses from the Horne 5 deposit suggests that zinc, copper and gold trends are roughly parallel to the east-southeast strike of the stratigraphy. Zinc contents are generally highest (>1%) within the main lenses of massive pyrite (Barrett et al, 1991).

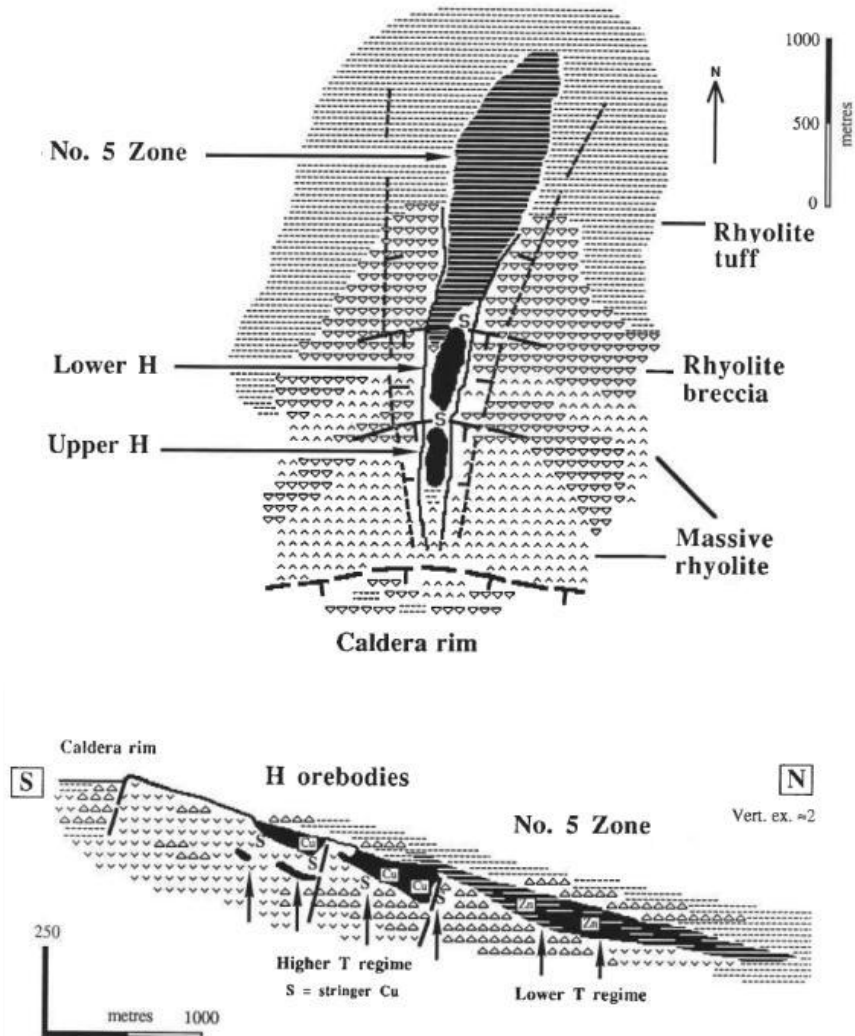

Top: plan view. Bottom: interpreted south to north cross-sectional reconstruction (scales approximate). The grabens are inferred to have formed along radial fault zones extending from the edge of a caldera complex, with crosscutting ring faults possibly bounding the Upper H and Lower H orebodies. In the model by Cattalini et al. (1993), the H orebodies formed through the infilling of two nearly contiguous grabens by sulphides (and locally volcanoclastic detritus). Cu-rich sulphides formed from high-temperature fluids that discharged near the restored northern ends of each subgraben and near the western and eastern walls of each orebody. In these areas, extensive mineralized, chloritic zones developed. The Horne 5 deposit formed from lower temperature, more diffuse discharge that produced stacked lenses of Zn-bearing massive pyrite within mineralized rhyolitic tuffs and breccias. The Horne 5 deposit was partly coeval with deposition of the H orebodies and locally younger where extensions of it overlie the Lower H orebody. (Modified from Barrett et al. 1991)

**Figure 7-9: Paleotopographic model for the relative locations on the flank of a rhyolitic edifice of the Upper H orebodies (proximal deep grabens) and the Horne 5 deposit (distal broad depressions)**

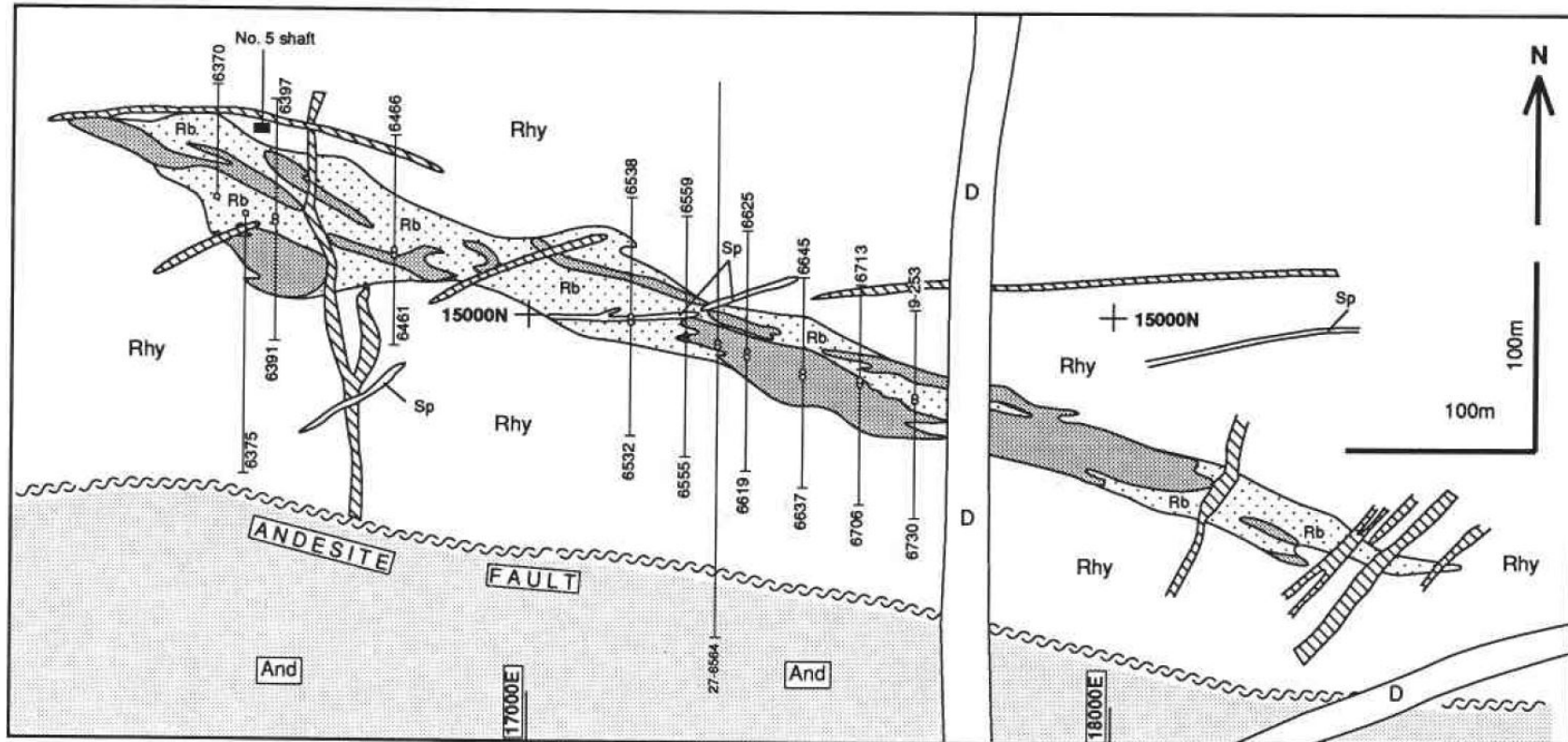

The Horne 5 deposit (light stipple) consists of a tabular series of intercalated zones of disseminated sulphides with lenses of pyritic massive sulphides (shaded), all broadly concordant with east-southeast-striking rhyolitic units. See legend of Figure 7-7. R= rhyolite; Rb= rhyolite breccia, Rt= rhyolite tuft Rc= chloritic rhyolite; Rs= sericitized rhyolite; stippled, massive sulphides; Sp= syenite porphyry; hachured= metadiabase dike; D= younger diabase dike; And= Andesite; Sh= shear zone. Drill holes used in the study by Barrett et al. (1991) are shown. Galleries were omitted for clarity. (From Barrett et al., 1991)

**Figure 7-10: Geology of level 27, Horne mine, based on unpublished maps of Noranda Mines Ltd.**

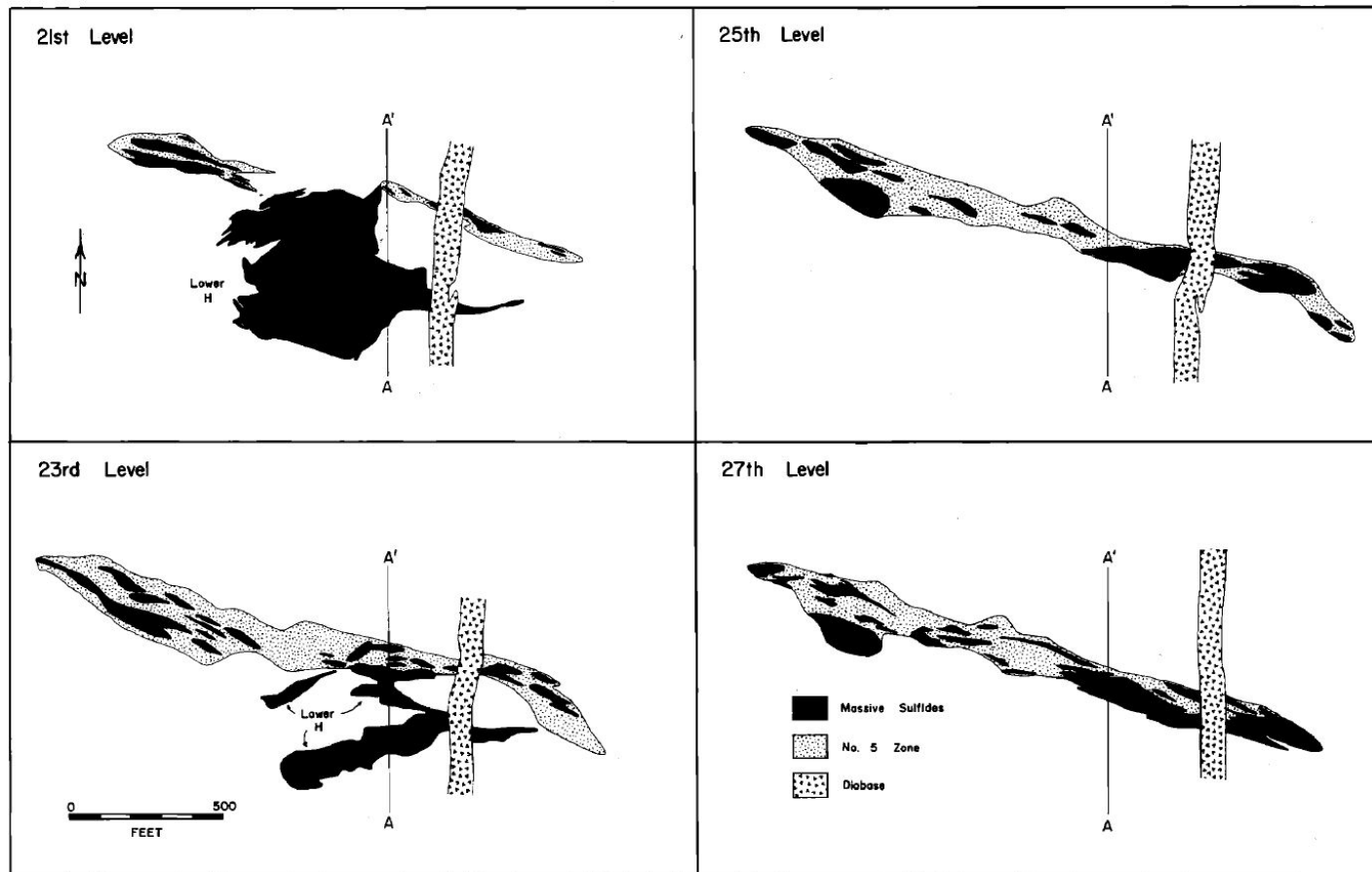

Figure 7-11: Composite level plans showing shape and distribution of massive sulphides in the Horne 5 deposit and their relationship to the Lower H orebody (From Sinclair, 1971)

Intercalated lenses of massive pyrite, 3–35 m thick, with local sphalerite enrichments, are most extensively developed between level 31 and level 41. On level 41, pyritic sulphides are very thick (~50 m). Between levels 41 and 65, there are semi-continuous lenses of massive pyrite 7–10 m thick. On level 65, a lens of disseminated mineralization is ~275 m wide and 6–25 m thick (there are no significant massive sulphide lenses). Silver values, which were determined only on level 65, are generally <35 g/t and average 12 g/t. From levels 21 to 57, the Horne 5 deposit is overlain by up to 60 m of un-mineralized rhyolite breccia, then by ~100 m of rhyolite tuff (Fisher 1970; Sinclair 1971).

The overall distribution of mineralization in the Horne 5 deposit is a series of slightly overlapping pyritic lenses within variably mineralized rhyolitic volcanoclastic rocks that are broadly concordant with stratigraphy over a width of ~750 m, a depth of ~1,800 m, and a thickness of 30–100 m. When restored to a paleohorizontal position, most of the zone would lie north of the Lower H orebody, which in turn would lie north of the Upper H orebody (Figure 7-9). The Horne 5 deposit appears to have stratigraphically overlapped the top of the lower H orebody at its original northern end (level 21) and to have accumulated in a broad depression that was elongated in a north-south direction (assuming no rotation on bounding faults). The depression was deepest between levels 37 and 41, where the total mass of sulphide is greatest. Here, the Horne 5 deposit was underlain by massive rhyolite at its (original) southern end, and by rhyolite breccias at its northern end.

Barrett et al. (1991) infer that two main systems of fault-controlled sub-vertical fluid discharge extended along the flanks of the Horne graben system from the sites of the H orebodies into the Horne 5 deposit, refer to Figure 7-14. The large Zn-bearing pyritic lenses in the Horne 5 deposit probably originated from lower temperature fluids than did those forming the Cu-rich H orebodies, but along extensions of the same synvolcanic fault system. Although the Horne 5 deposit massive sulphides are richer in zinc, lead, antimony, arsenic and cadmium, they are much lower in copper and gold than those of the H orebodies; they lack the Cu-rich cores common in Kuroko-type massive sulphide deposits (cf., Eldridge et al. 1983, in Barrett et al, 1991). Two elongated zones of somewhat higher gold contents in the Horne 5 deposit may mark the general locations of hydrothermal discharge in this area (Kerr and Mason, 1990; Figure 7-9 and Figure 7-14). These Au-rich pyritic lenses were partially mined from 1967 to 1976.



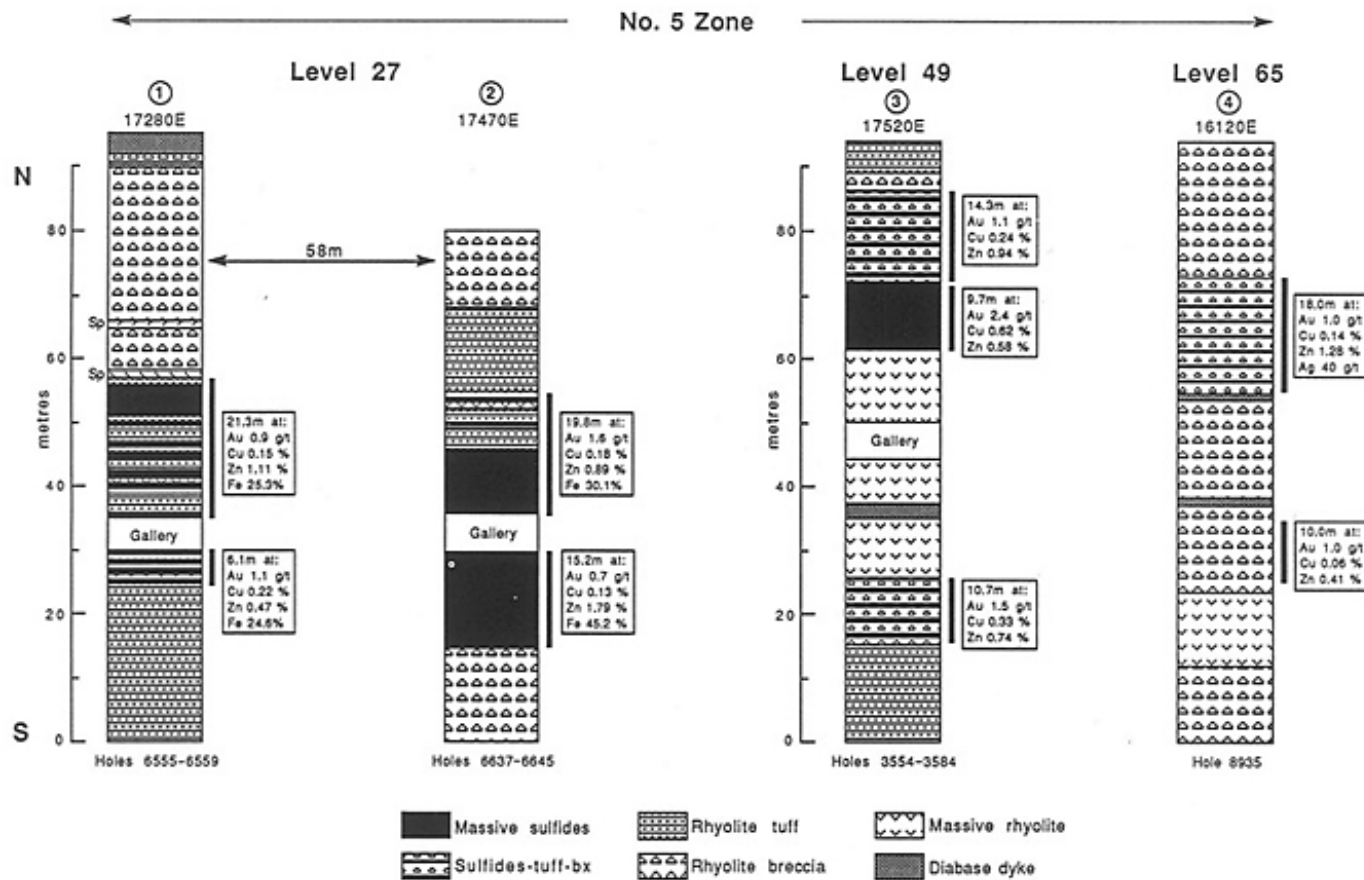

Figure 7-12: Host rock – orebody sequences of the Horne 5 deposit, along horizontal drilling transects on levels 27, 49 and 65  
 Host rocks show younging to the north. The two transects shown in level 27 display along-strike variations in mineralization that are typical of the Horne 5 deposit. Note the generally low Cu-Au contents of massive-sulphide-rich sections relative to H orebodies. Bx = breccia. All data from logs of Noranda Mines Ltd. (from Barrett et al., 1991).

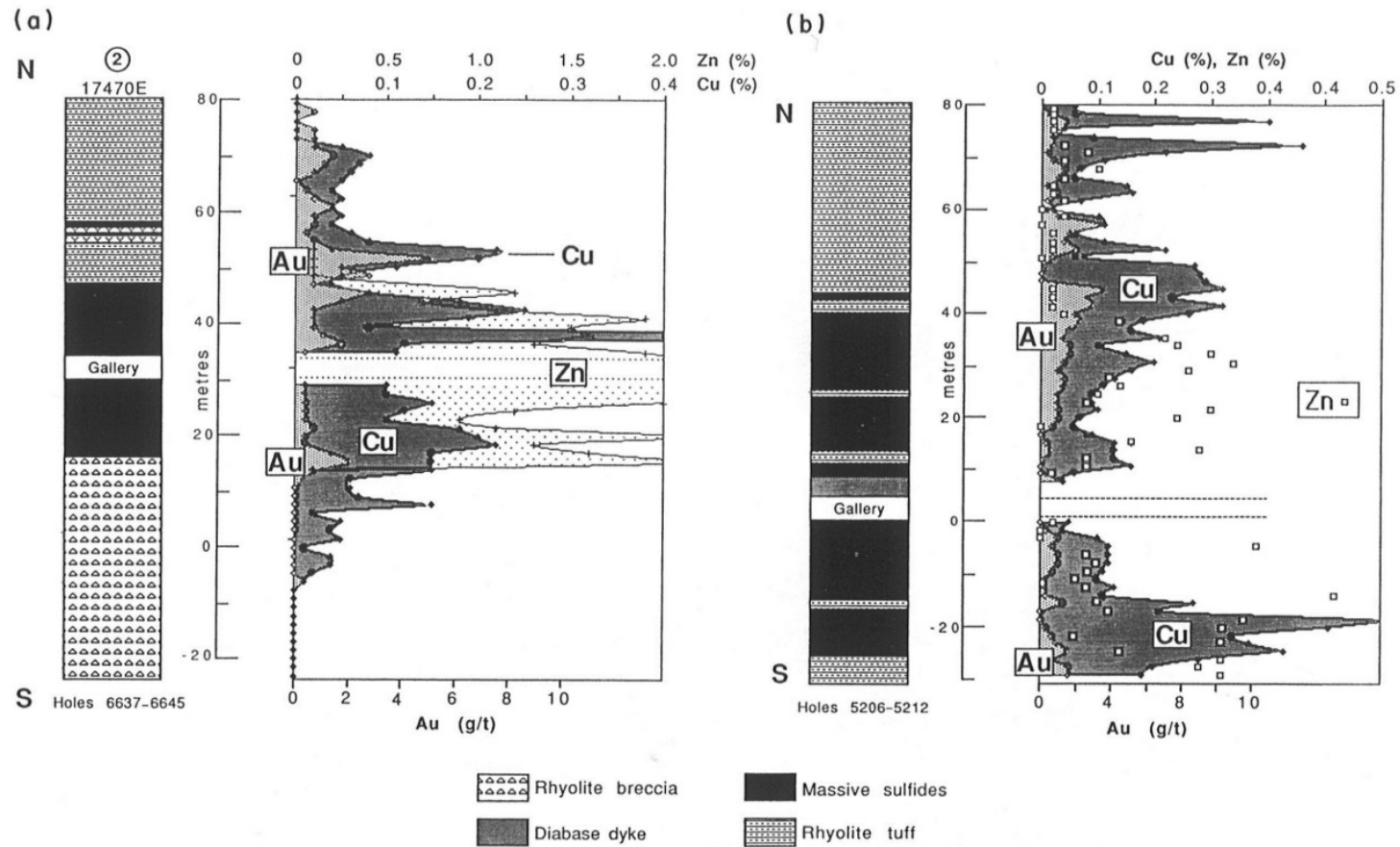

Figure 7-13: Cu-Au-Zn profiles of the Horne 5 deposit, along horizontal drilling transects on levels 27 (a) and 41 (b)  
 Note the generally low Cu-Au contents of the massive sulphide-rich sections relative to the H orebodies. Host rocks display younging to the north.  
 All data from logs of Noranda Mines Ltd. (from Barrett et al., 1991).

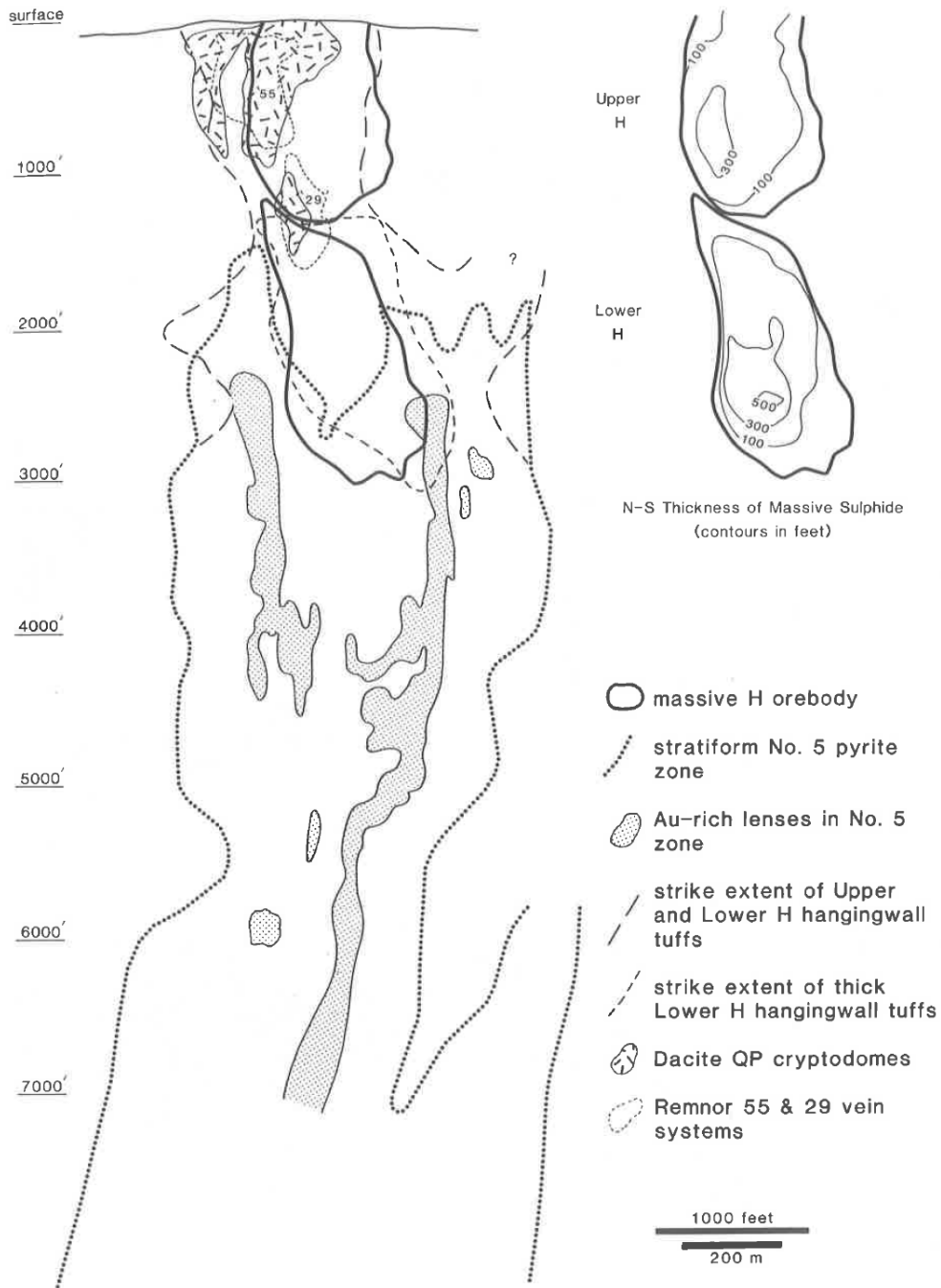

Figure 7-14: Longitudinal section through the Horne mine, looking north, showing Au-rich spines within the Horne 5 deposit (From Kerr and Mason, 1990)



### 7.3.3 Identification of Gold Mineralization

For the purpose of the previous mineral resource estimate (March 2016 MRE; Jourdain et al., 2016), InnovExplo defined and modelled four mineralized envelopes (ENV\_A, ENV\_B, ENV\_C and ENV\_D) between depths of 600 m and 2,600 m below surface as per Figure 7-15. The deposit is sub-vertical to dipping steeply to the south, with a length of 500 m to 800 m and a thickness ranging from 7 m to 120 m. The main mineralized envelope (ENV\_A) consists of a disseminated to massive sulphide body hosted by rhyolite. ENV\_B, ENV\_C and ENV\_D consist of low-grade gold zones that were defined using an approximate cut-off grade of 0.5 g/t Au. ENV\_B and ENV\_C are concordant to ENV\_A and located north of it, whereas ENV\_D is located at depth and is slightly discordant to ENV\_A.

For the purpose of the November 2016 MRE, two additional mineralized envelopes were identified. The first, ENV\_E, is located close to the top of ENV\_A, between levels 19 and 18, and the mineralization it contains presents typical Horne 5-style characteristics (semi-massive to massive sulphides) (Figure 7-16) and polymetallic contents. ENV\_E corresponds to the historical “D Zone” identified by Noranda. The second, ENV\_F, is located south of ENV\_A, but close to it, between levels 29 to 35, and the mineralization it contains corresponds to an auriferous quartz-rich zone (vein-style zone) that was referred to by Noranda as the “Quartz Vein” area, see Figure 7-17.

The interpretation of ENV\_A takes into account assays for gold (approximate cut-off grade of 0.5 g/t Au), copper and zinc, in addition to specific gravity (which correlates well with sulphide content) and the geological mapping of underground workings (which delineates disseminated and massive sulphide facies). ENV\_A is zoned with respect to gold, copper, zinc and sulphide contents.

In the March 2016 MRE, InnovExplo defined and modelled five high-grade gold zones within ENV\_A, between depths of 600 m and 1,600 m: HG\_A, HG\_B, HG\_C, HG\_D and HG\_E (Figure 7-18).

During the November 2016 MRE exercise, an additional high-grade gold zone—HG\_F—was identified at depth within ENV\_A, refer to Figure 7-18. The HG\_F zone was delineated between levels 57 and 65, and is supported by an approximate interpretation cut-off grade of 2.5 g/t Au for gold, the same cut-off used in the March 2016 MRE for the high-grade domain interpretation. Furthermore, the position of HG\_F is consistent with the high-grade gold trend dipping steeply to the west. This trend, identified historically by Noranda, supports the six high-grade gold zones defined to date on the Horne 5 deposit, refer to Figure 7-19.

Figure 7-20 to Figure 7-22 show the high-grade zones defined within ENV\_A for copper, zinc and specific gravity, respectively.

There is no established correlation between InnovExplo’s high-grade zone nomenclature and Noranda’s historical gold-rich lenses. The latter were based on a higher gold cut-off of approximately 6.0 g/t Au.

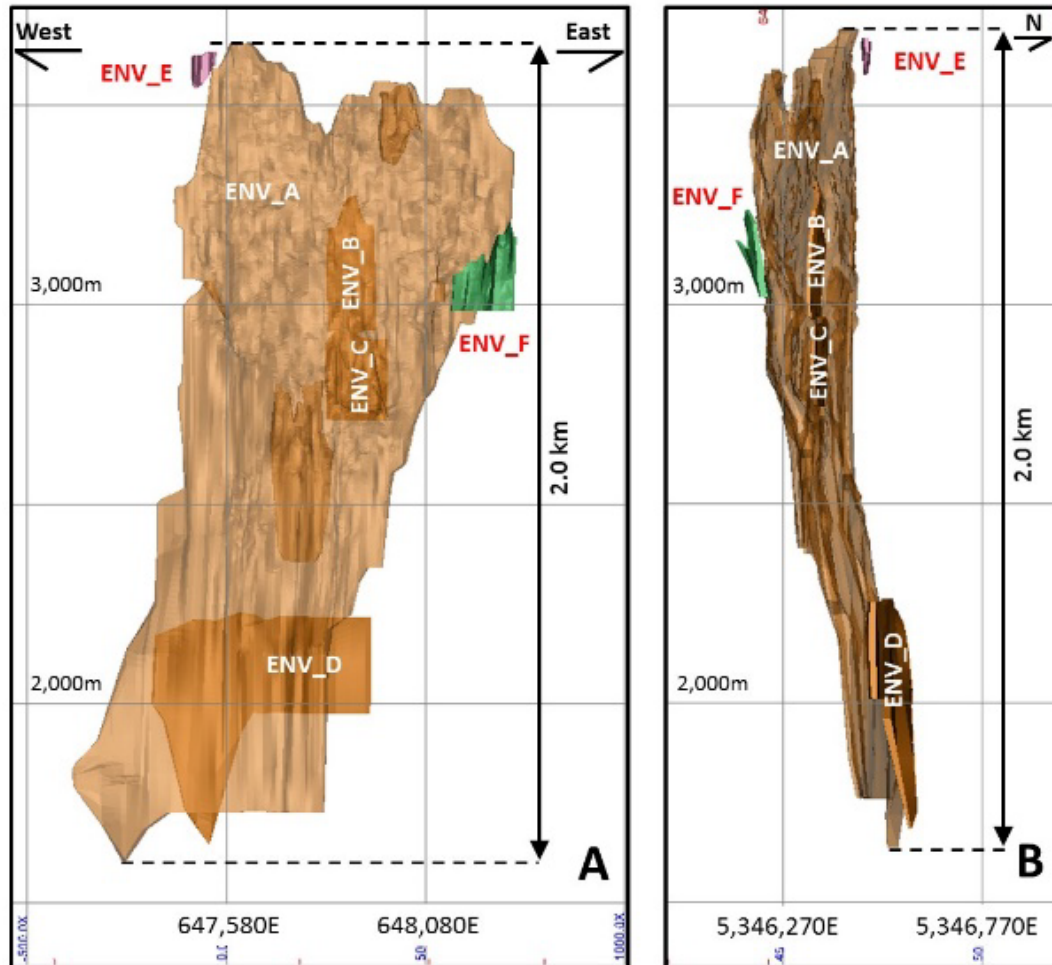

Figure 7-15: Horne 5 mineralized envelopes  
A) Longitudinal view (looking north); B) Cross section (looking west). The new mineralized envelopes (ENV\_E and ENV\_F) are labelled in red.

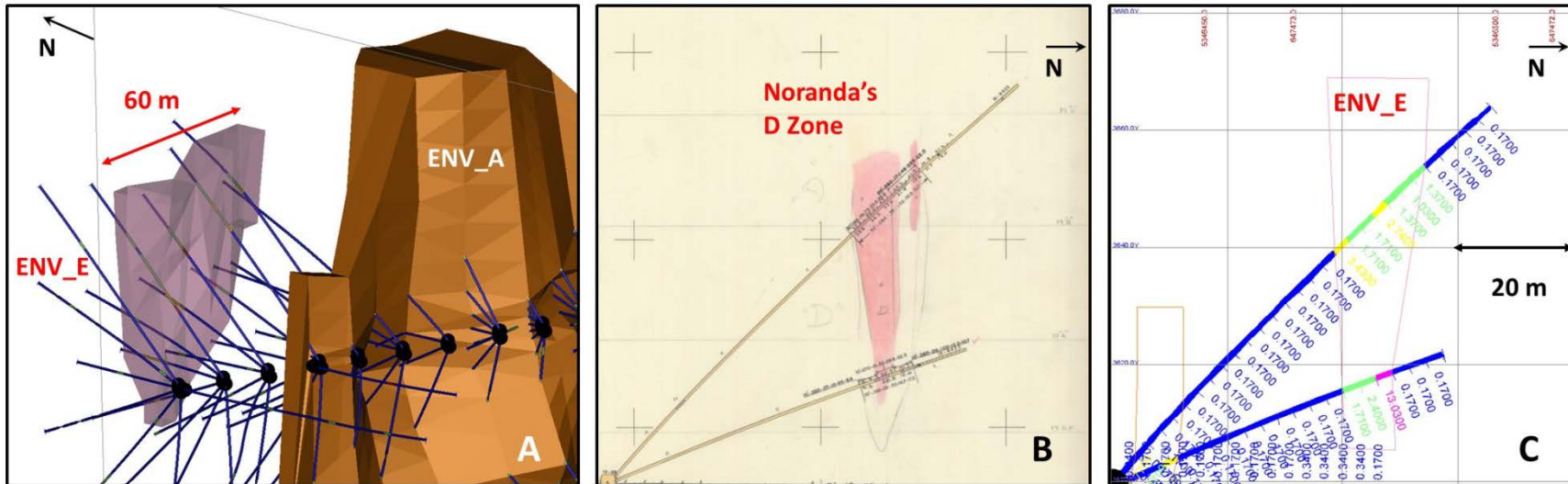

Figure 7-16: Additional mineralized envelope ENV\_E

A) 3D view looking north east, illustrating the shape of the envelope and its proximity to the western top of ENV\_A. Also shown is the radiating drilling fan supporting both envelopes; B) Vertical cross section view, looking west from Noranda's historical workings, showing the interpretation of the "D Zone"; C) Vertical cross section view looking west, showing the interpretation of ENV\_E based on data included in the November 2016 MRE.

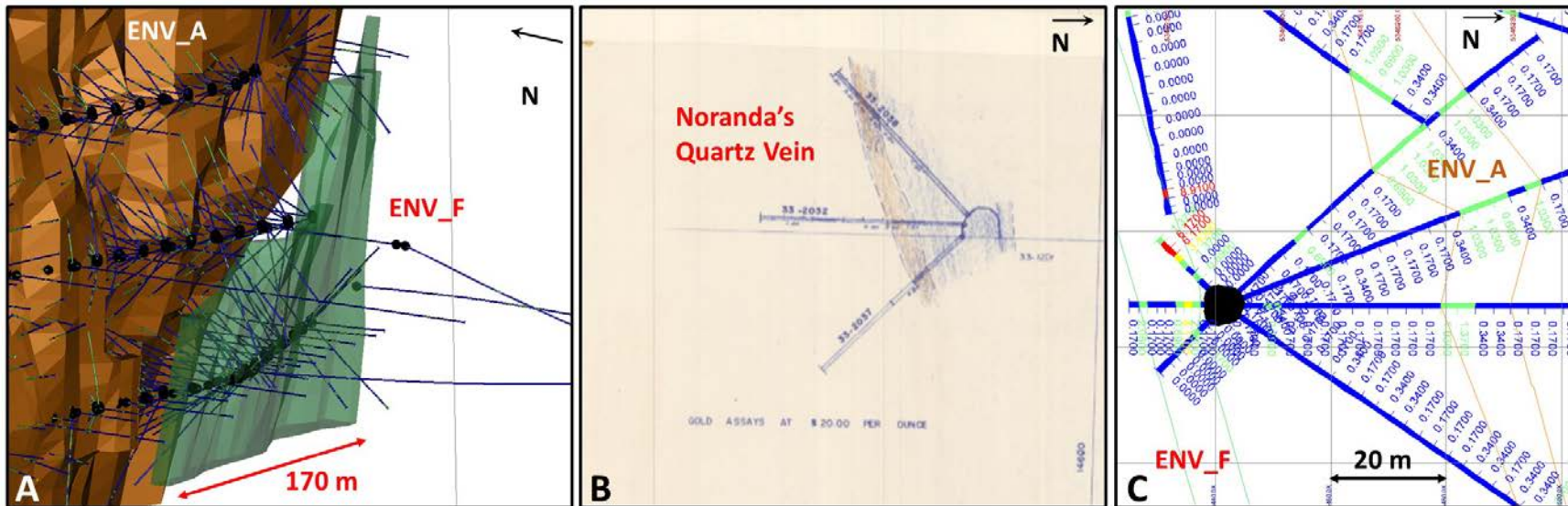

Figure 7-17: Additional mineralized envelope ENV\_F

A) 3D view looking northeast, illustrating the shape of the envelope, its proximity to the south side of ENV\_A, and the drilling pattern supporting both envelopes; B) Vertical cross section view, looking west from Noranda’s historical workings, showing the interpretation of the “Quartz Vein”; C) Vertical cross section view looking west, showing the interpretation of ENV\_F based on data included in the November 2016 MRE.

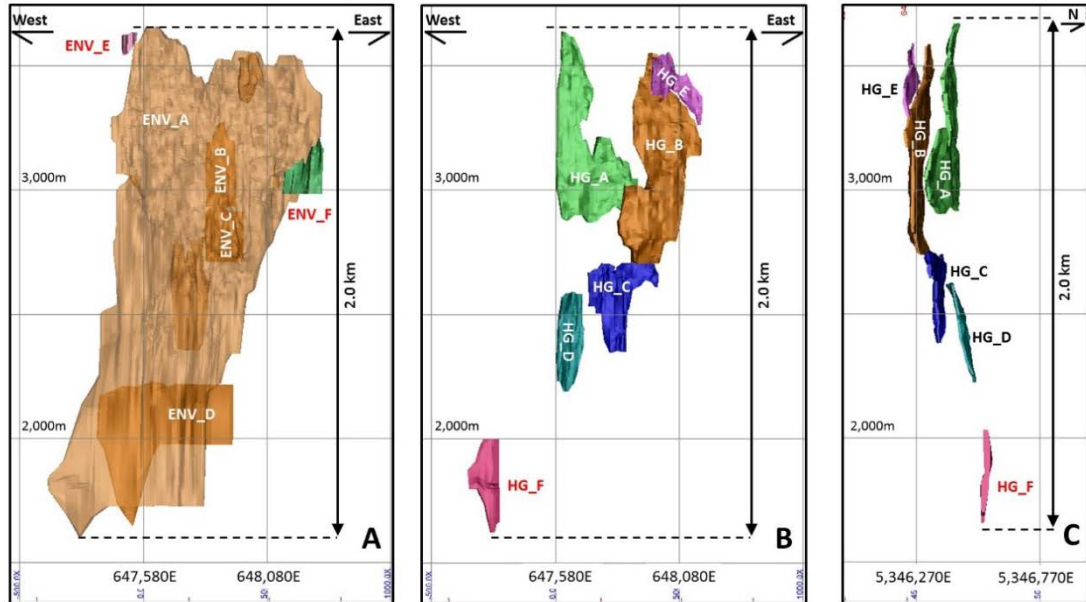

Figure 7-18: Horne 5 mineralized envelopes and high-grade gold zones  
A) Longitudinal view (mineralized envelopes); B) Longitudinal view (high-grade gold zones);  
C) Cross section (high-grade gold zones).  
The new high-grade gold-bearing zone (HG\_F) is labelled in red.



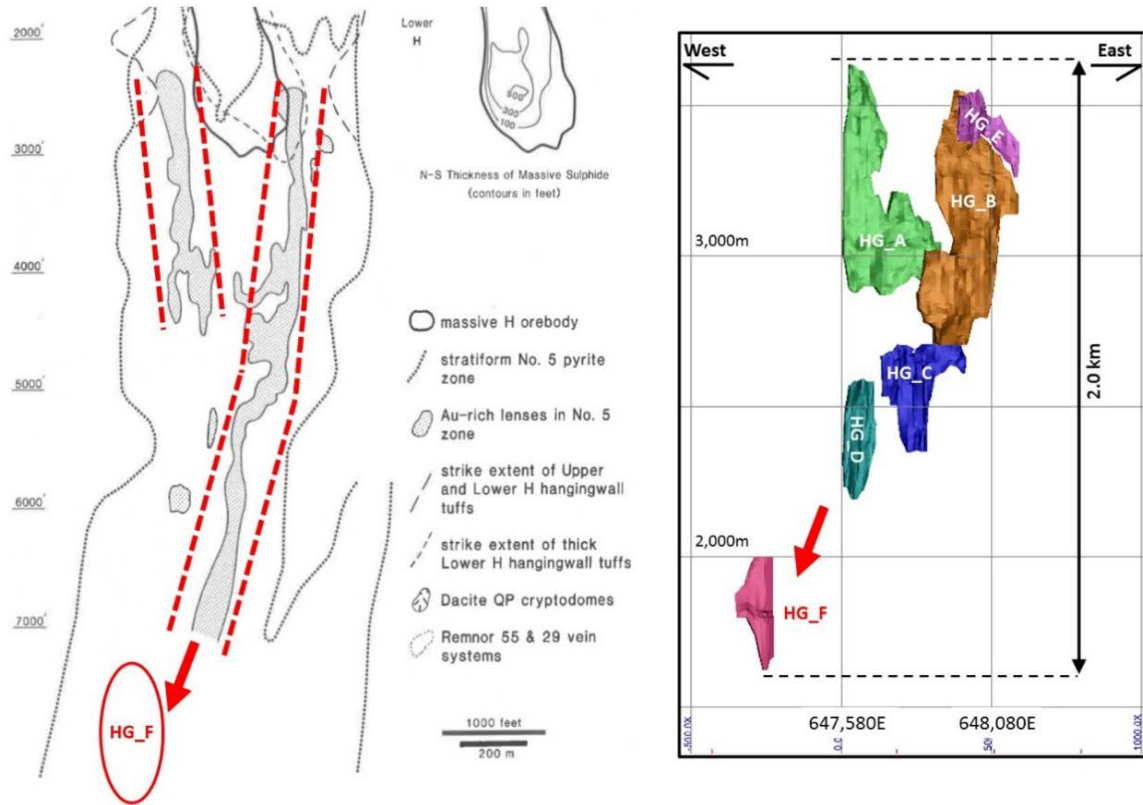

Figure 7-19: Horne 5 historically delineated high-grade Au-bearing trend (left), compared to the high-grade Au-bearing zones defined in the November 2016 MRE (right)

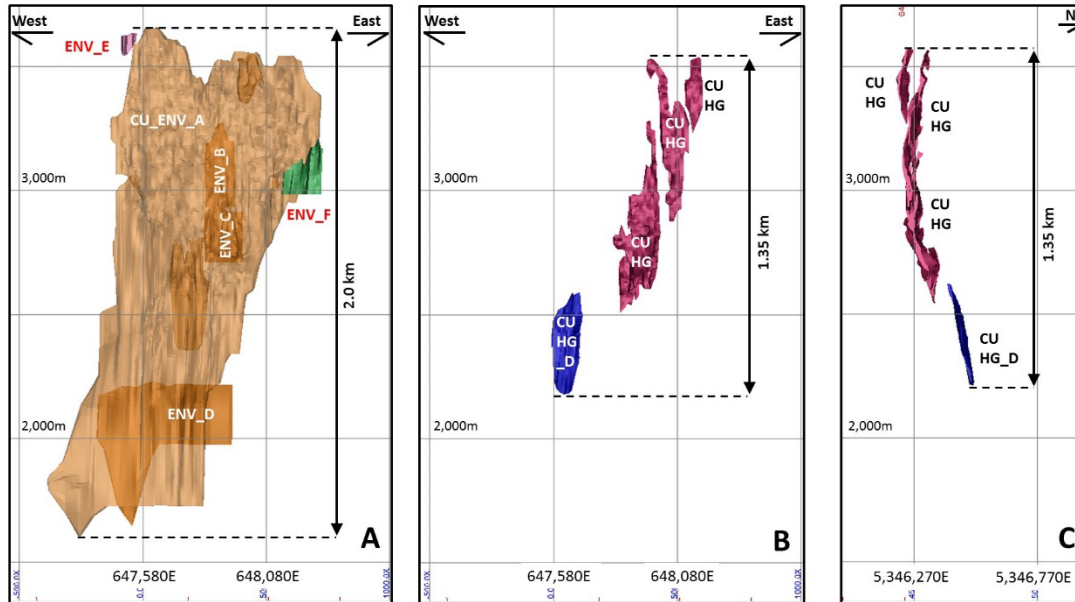

Figure 7-20: Horne 5 mineralized envelopes and high-grade Cu zones  
 A) Longitudinal view (ENV\_A); B) longitudinal view (high-grade Cu zones);  
 C) cross section (high-grade Cu zones)

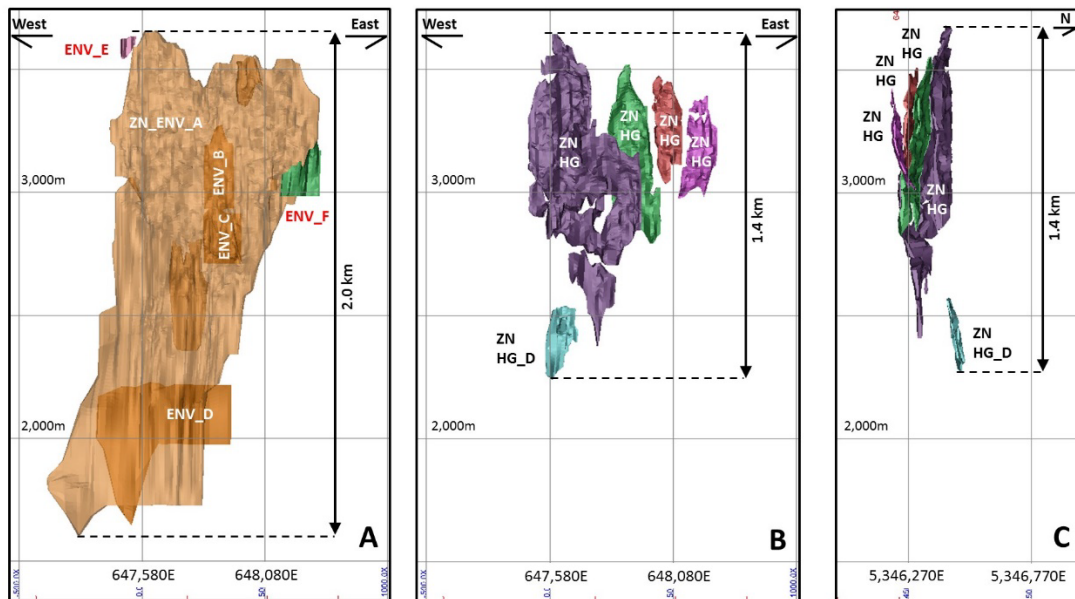
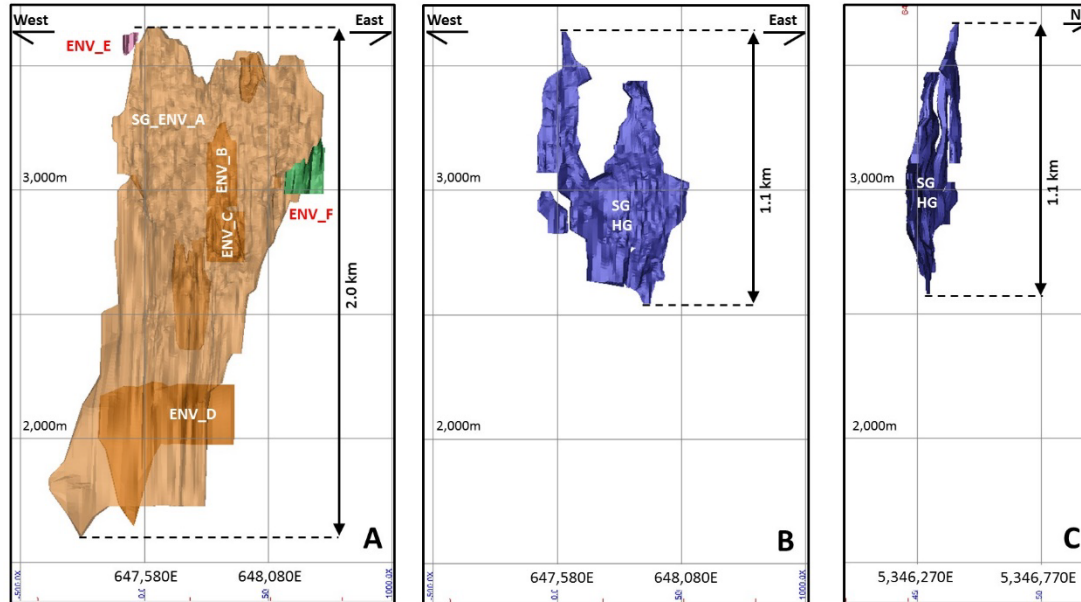

Figure 7-21: Horne 5 mineralized envelopes and high-grade Zn zones  
 A) Longitudinal view (ENV\_A); B) Longitudinal view (high-grade Zn zones);  
 C) Cross section (high-grade Zn zones)





**Figure 7-22: Horne 5 mineralized envelopes and zones of high specific gravity**  
 A) Longitudinal view (ENV\_A); B) Longitudinal view showing zones of high specific gravity zones);  
 C) Cross section showing zones of high specific gravity

### 7.3.4 Lithostructural Model

The aim of the previous lithostructural model for the Horne 5 deposit was to model the main lithological families and major structures in the deposit and its immediate vicinity. The work was supported by Noranda’s historical geological interpretation (Figure 7-23) supplemented by 2D and 3D modelling by De Kemp. The 2015 lithostructural model (Figure 7-24) comprises 3D wireframes (lithology and sulphide envelopes) and surfaces (major faults).

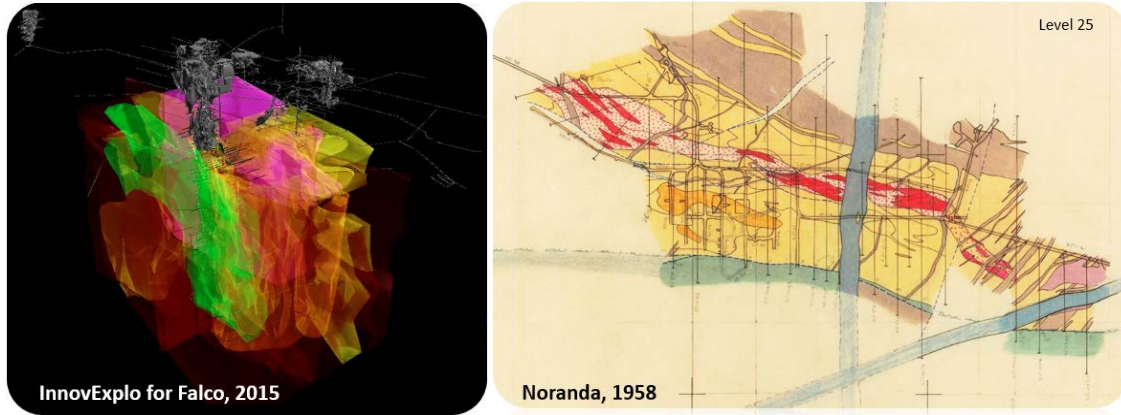

Figure 7-23: Horne 5 lithostructural model constructed in 2015 (left); Noranda's geological interpretation constituted the main support (right) to construct the 3D model

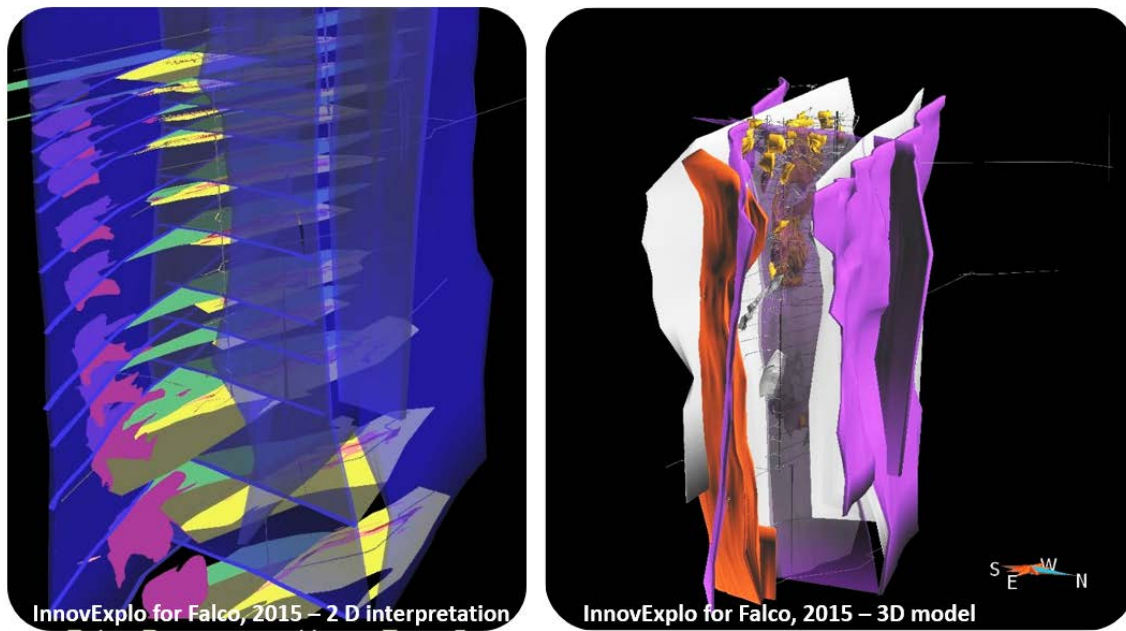

Figure 7-24: Support for the 2015 Horne 5 lithostructural model in the form of a 2D geological interpretation realized on key plan views (left) Modelling was performed for synvolcanic rocks and also for late geological events such as diabases and major faults (right).

In order to enhance the geological accuracy of the 2015 model and broaden its coverage in terms of its lithological, mineralization, structural and alteration features, a global compilation of geological drill hole information and underground mapping information was completed in 2016.

This approach was adopted for the following reasons:

- Recovery – through a more accurate estimate of the contents of minerals other than pyrite in mineralized material;
- Comminution – through a more accurate determination of host rock versus massive sulphide ratios, and characterization of host rock types;
- Rock mechanics – through defined more refined lithostructural model;
- Waste development – through more accurate sulphide estimates for development waste rock in order to better estimate the acid generation potential of the material;
- Mineralized zones – through better defined mineralized zone geometries.

Because of its polymetallic content and VMS features, the Horne 5 deposit mineralizations are intimately associated with stratigraphy of volcanic felsic units and content and distribution of sulphides.

Compiling approach is described in the exploration section of the herein report (See Chapter 9 – Exploration – Geological information from historical underground drill holes). Horne 5 lithostructural models have been updated by Francine Fallara, P. Geo., Guilhem Servelle, P. Geo., and Stéphane Faure, P. Geo.

InnovExplo puts the emphasis on lithologies, structures, sulphide content and mineralizations, and alteration footprints.

### Lithologies

- Rhyolite (Massive) (Figure 7-25);
- Rhyolithe (Brecciated) (Figure 7-25);
- Rhyolithe (Tuffaceous) (Figure 7-25);
- Rhyolithe (Quemont mine area) (Figure 7-25);
- Andesite (Figure 7-25);
- Metadiabase (Figure 7-26);
- Metadiabase (Dyke M) (Figure 7-26);
- Diabase (Figure 7-27);
- Granite (Figure 7-27);
- Syenite (Figure 7-27).

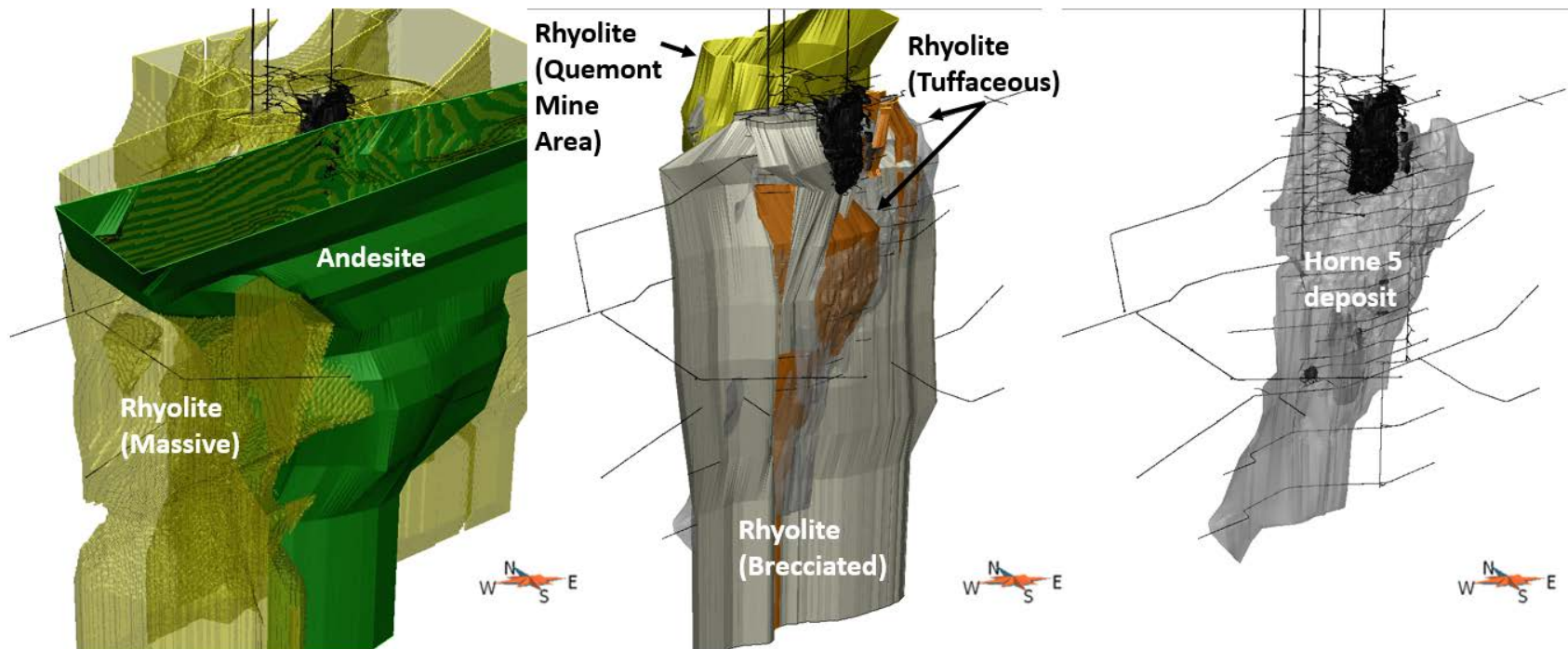

Figure 7-25: 3D view of updated Horne 5 lithostructural model for volcanic lithologies  
The Horne 5 deposit is exclusively related to rhyolite (central picture). The Horne 5 deposit itself occurs in interlayered units of brecciated and tuffaceous rhyolite sub-facies (left picture). Horne 5 deposit ENV\_A is shown for illustrative purposes.

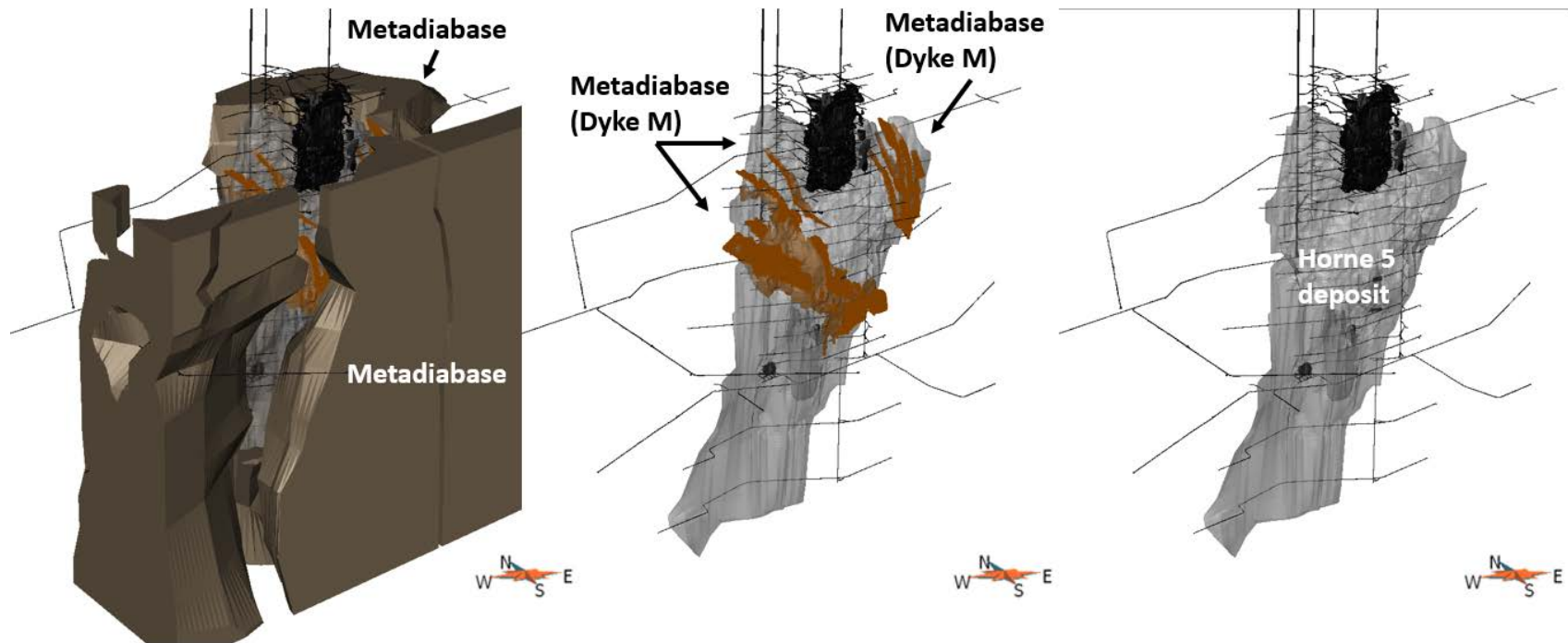

Figure 7-26: 3D view of updated Horne 5 lithostructural model for synvolcanic diabases (metadiabases)

The most important metadiabases occur in the vicinity of the Horne 5 deposit on its northern and southern sides (central pictures). The metadiabases which diluted the Horne 5 deposit (Metadiabase (Dyke M)) have been modeled accurately using DDH and historical interpretation on vertical cross-section (left picture). Horne 5 deposit ENV\_A is shown for illustrative purposes.



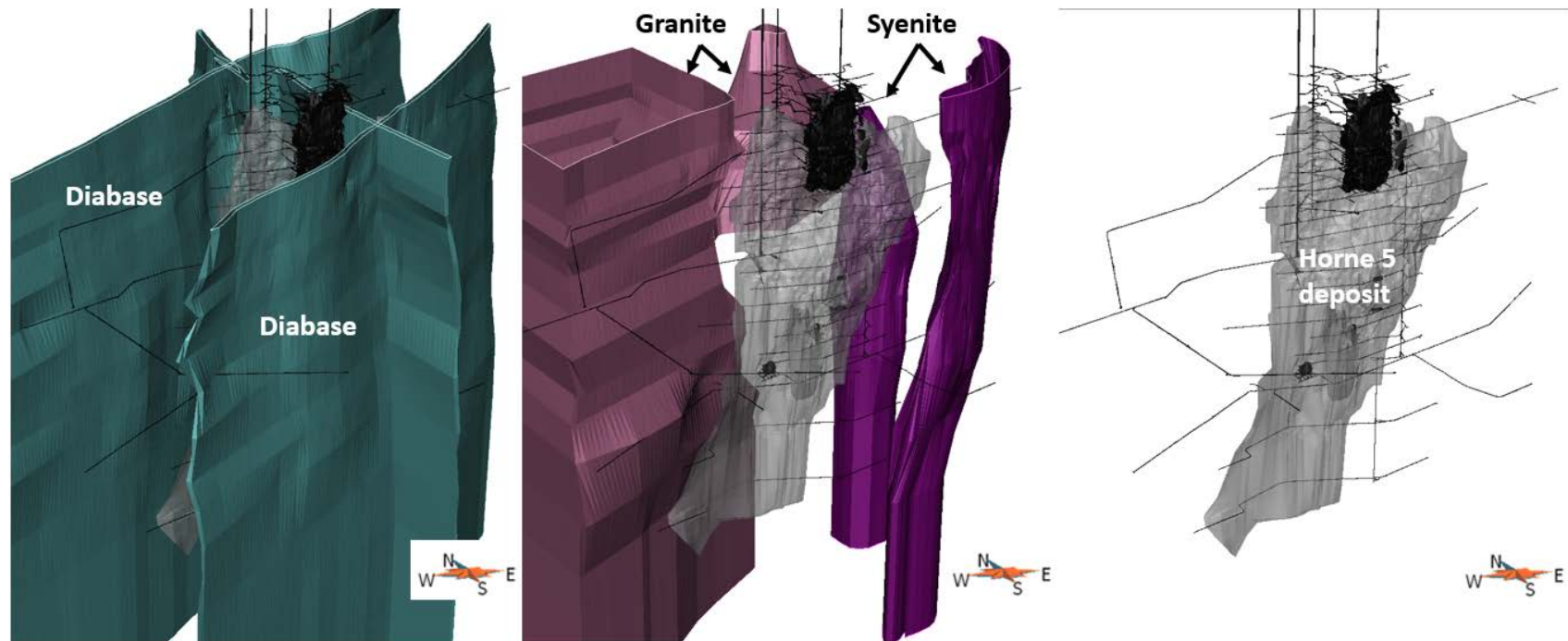

Figure 7-27: 3D view of updated Horne 5 lithostructural model for late-tectonic (Proterozoic) diabases (left) and granite and syenite stocks (centre)  
The ENV\_A model of the Horne 5 deposit is shown for illustrative purposes (right).

---

## Structures

- Major faults (Figure 7-28):
  - Horne-Creek Fault;
  - Andesite Fault;
  - No\_Name Fault;
  - Strong Fault.
- Secondary faults (Figure 7-29);
- Historical secondary faults (Figure 7-29).



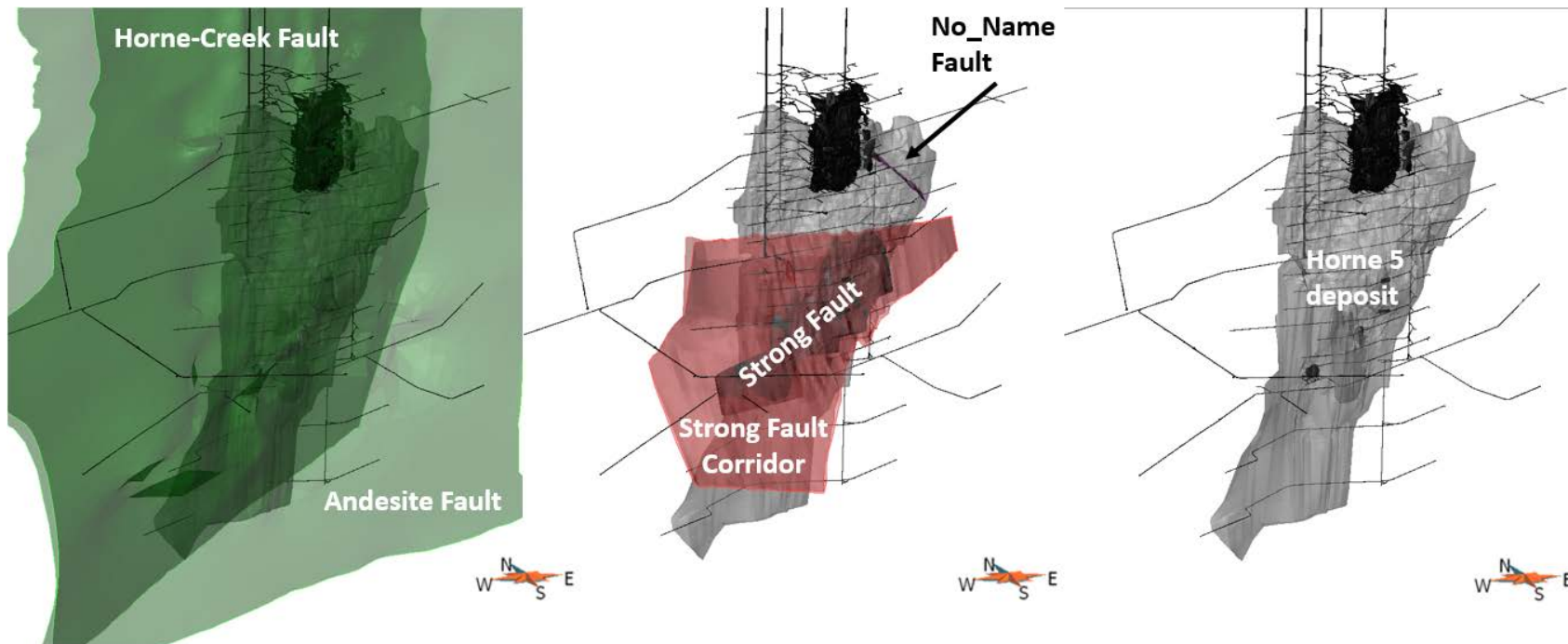

Figure 7-28: 3D view of the updated Horne 5 lithostructural model for major faults

Horne-Creek and Andesite faults constitute the northern and southern boundaries, respectively, of the Horne 5 lithology block before converging 2.2 km west of the deposit (central picture). Horne-Creek and Andesite faults do not affect the Horne 5 deposit itself. No\_Name and Strong Faults cut across the deposit with two different attitudes without significant displacement (right picture). The updated model also reveals a sheared corridor buffering the No\_Name Fault itself (right picture). The Horne 5 deposit ENV\_A model is shown for illustrative purposes (right).

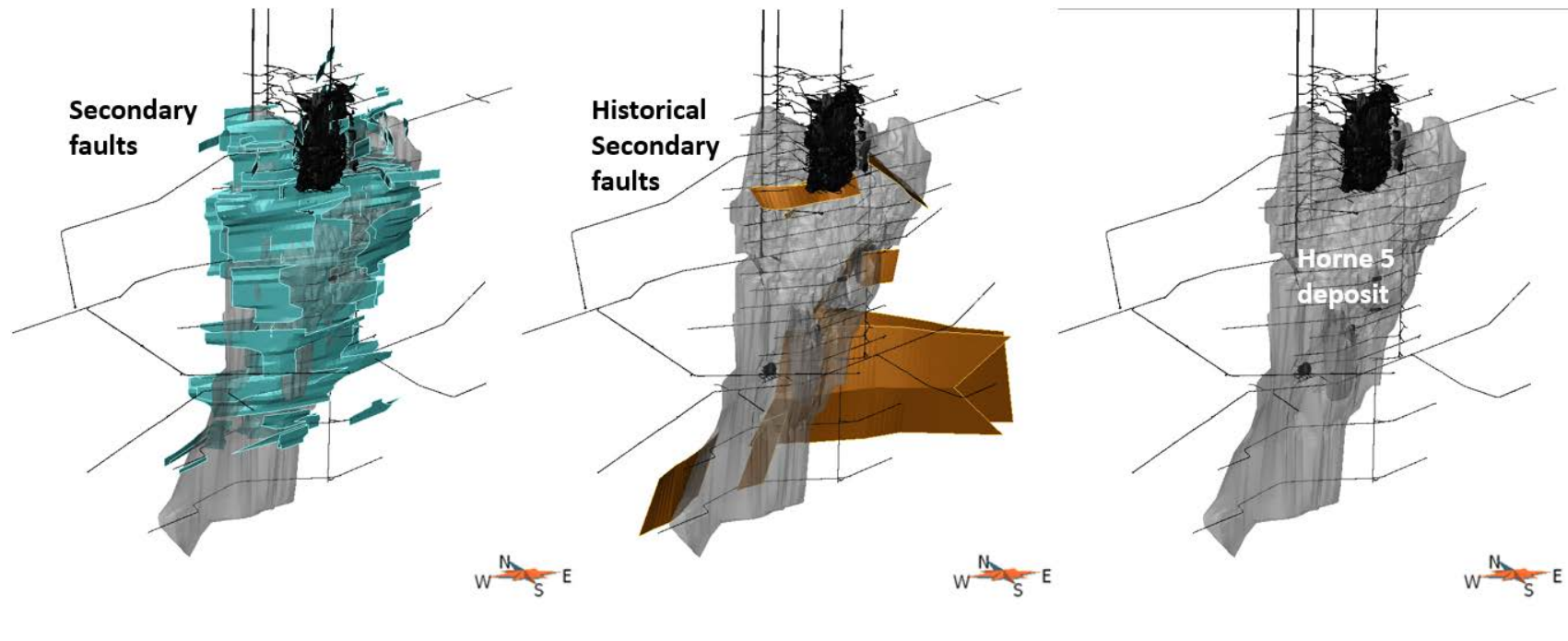

Figure 7-29: 3D view of updated 2016 Horne 5 lithostructural model for secondary faults  
More than 100 individual panels have been modelled based on DDH and underground mapping information (left). Historical secondary faults, from De Kemp works mainly, have been also used (centre). The Horne 5 deposit ENV\_A model is shown for illustrative purposes (right).

---

## Sulphide Content and Mineralization

- Massive sulphide envelope (Figure 7-30) supported by the following: semi-massive to massive historical lithological descriptions from DDH, normalized sulphide percentage (%) derived from qualitative descriptions in historical DDH, copper and zinc raw assays (%) converted into percentage of theoretical sulphides using the stoichiometric formulas of chalcopyrite and sphalerite;
- Implicit iso-shells for mineralization (in %) derived from qualitative descriptions in historical DDH:
  - Pyrite (PY);
  - Chalcopyrite (CP) (Figure 7-30);
  - Sphalerite (SP);
  - Magnetite (MT) (Figure 7-30);
  - Pyrrhotite (PO);
  - Galena (GN);
  - Hematite (HT).

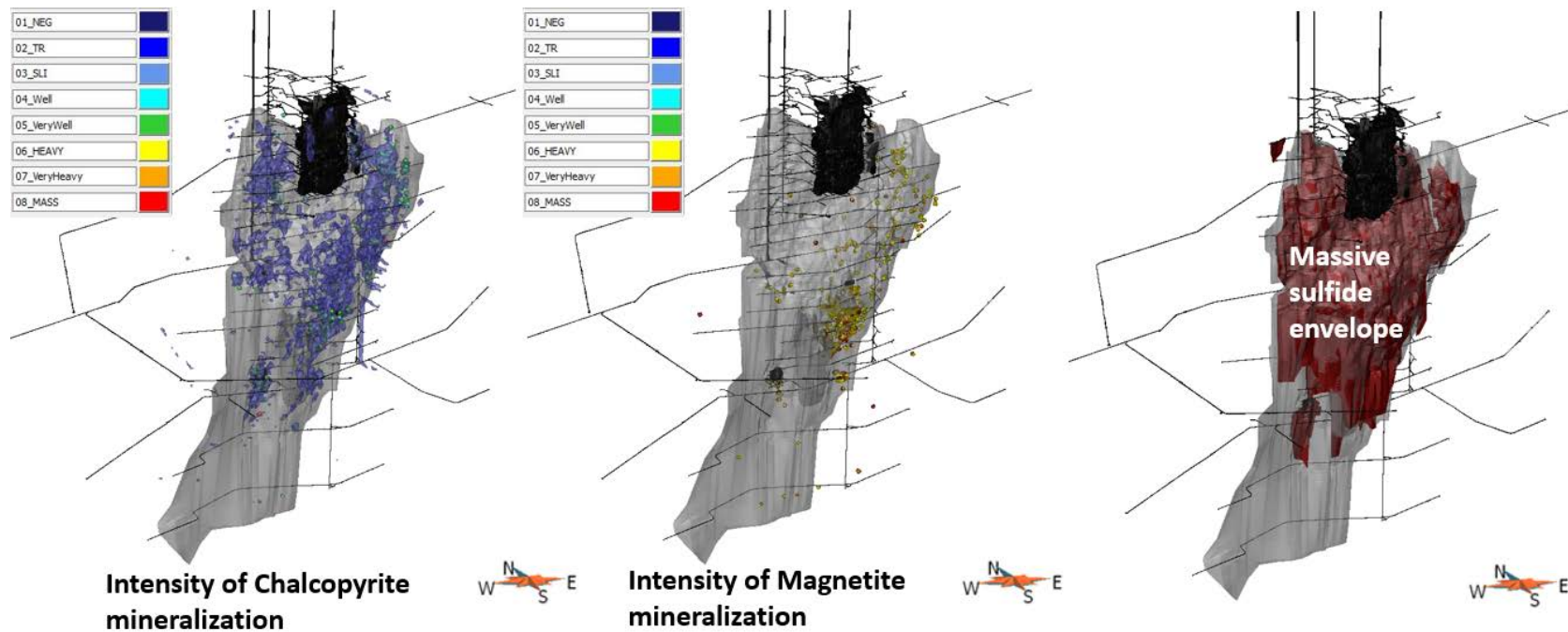

Figure 7-30: 3D view of updated Horne 5 lithostructural model for the massive sulphide envelope (left) and mineralizations (central and right)  
 Chalcopyrite intensity is illustrated from 0.5% and more well correlate with the high-grade gold-bearing trend historically identified and currently delineated by HG\_A to HG\_F gold-rich zones (central picture). Magnetite mineralization, which occurs on the eastern upper and central portion of the deposit, was also observed on confirmation drill holes (right picture). Horne 5 deposit ENV\_A is shown for illustrative purposes.

## Alteration Footprints

- Implicit iso-shells for alteration footprints by type (expressed by presence, i.e., all intensities and by intensity level derived from qualitative historical descriptions in DDH):
  - Carbonate (CB);
  - Chlorite (CL);
  - Black Chlorite (CLB);
  - Epidote (EP);
  - Silica (SI);
  - Pink Silica (SIP) (Figure 7-31);
  - Sericite (SR) (Figure 7-31).
- Implicit iso-shells for alteration footprints by intensity (merging all alteration types):
  - Weakly;
  - Moderate;
  - Strong;
  - Very;
  - Highly;
  - Very Highly.

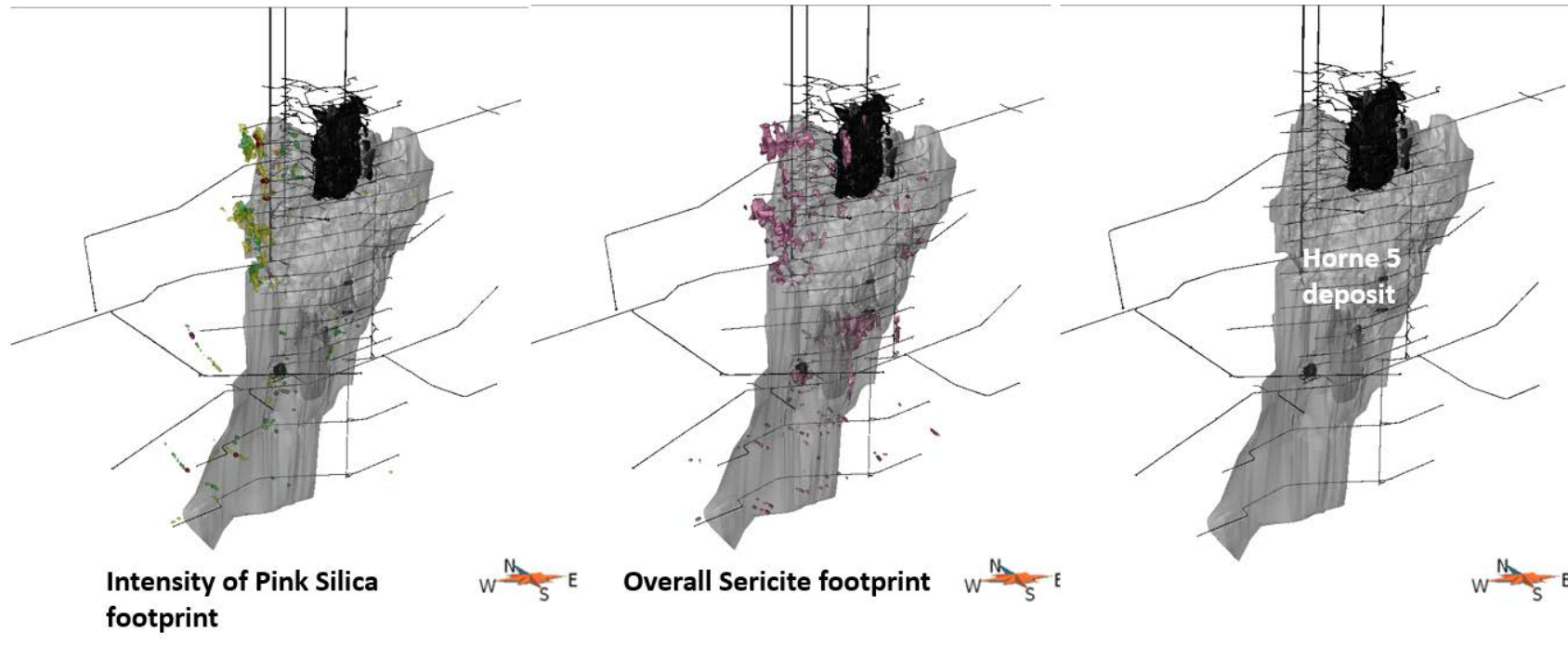

Figure 7-31: 3D view of updated Horne 5 lithostructural model for alterations

Pink silica footprint, widely observed on the western upper portion of the deposit, is illustrated from strong to very highly intensities (central picture). Overall Sericite footprint shows also a predominant distribution on the western upper portion of the deposit (right picture). Horne 5 deposit ENV\_A is shown for illustrative purposes.

---

## Veins

- Implicit iso-shells for vein types (Figure 7-32) (by presence derived from qualitative historical descriptions in DDH):
  - Quartz;
  - Carbonate;
  - Epidote.



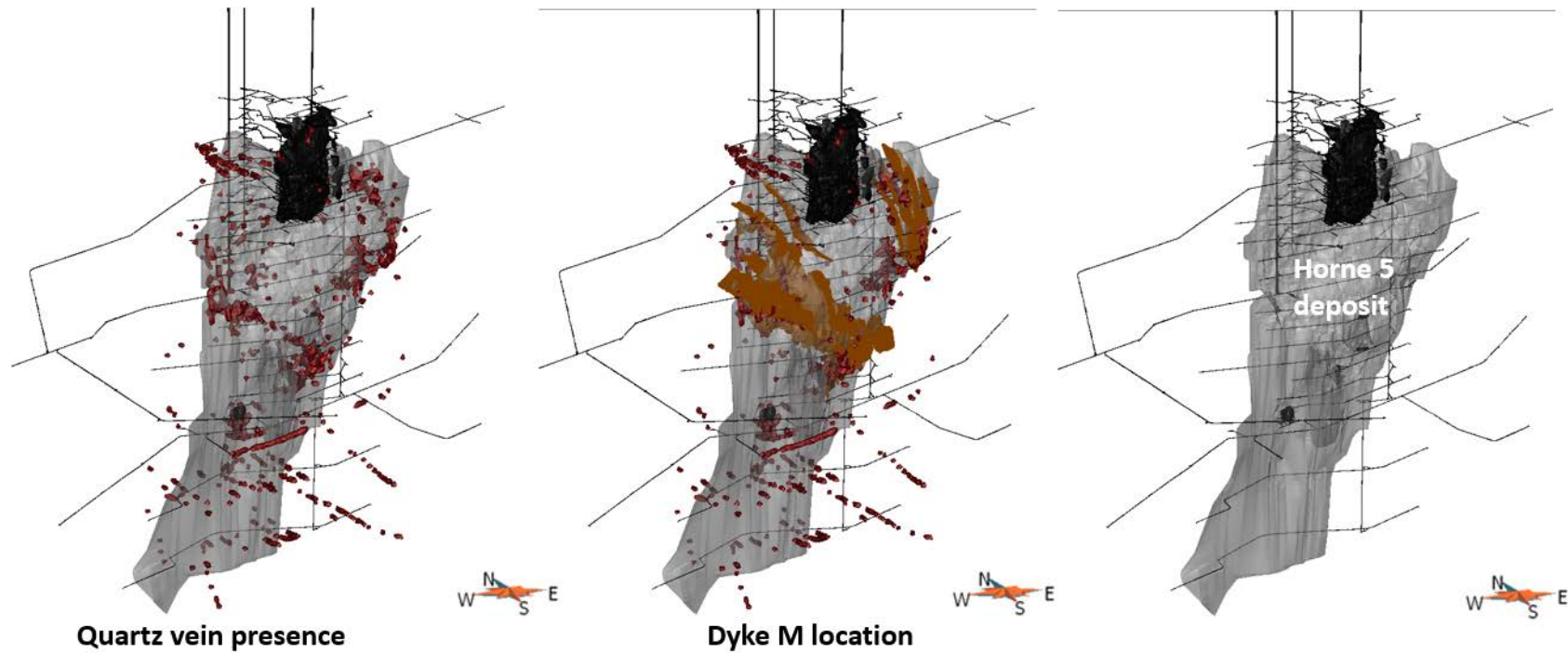

Figure 7-32: 3D view of updated Horne 5 lithostructural model for veins  
Quartz veins are barren and occur overall on the deposit according varying density (central picture). Several of the densest areas well correlate spatially with the presence of Dyke M metadiabases (right picture). Horne 5 deposit ENV\_A is shown for illustrative purposes.

The updated lithostructural model of the Horne 5 deposit constitutes a major step concerning range of usable geological information for the feasibility purposes. Solids and surfaces produced allow to establish zonation for rock mechanics, metallurgical, mining and geological features:

- Recovery – Eight sulphides and oxides have been identified and allow increasing relevantly nature and spatial distribution of mineralization through the deposit. Moreover, as an example, zonation of pyrrhotite occurrences helps also prevent some metallurgical issues.
- Comminution – The updated massive sulfide envelope, rhyolite facies and siliceous alteration footprints allow to establish a hardness model for milling;
- Rock Mechanics – The updated major and secondary faults model supplemented by the updated massive sulphide envelope, rhyolite facies, siliceous alteration footprint and the accurate design of Metadiabase (Dyke M) allow to significantly improve the constrain model;
- Waste Development – The more accurate sulphide estimates and the accurate design of Metadiabase (Dyke M) allow to improve prediction of nature of waste rock development in order to better estimate the acid generation potential of the material; and
- Mineralized Zones – The refined design of sulphide envelope allows improving interpretation of massive sulphides lenses, mainly on the deepest portion of the deposit where “en echelon” massive sulphide lenses distribution is observed. Mineralization type, distribution and intensity allow refining geometry of the deposit and could potentially help for proximal exploration purposes.

## 8. DEPOSIT TYPES

### 8.1 Volcanogenic Massive Sulphide Deposits

The following description of volcanogenic massive sulphide (“VMS”) deposits is summarized from Galley et al. (2007).

VMS deposits are also known as volcanic-associated, volcanic-hosted, and volcano-sedimentary-hosted massive sulphide deposits. They typically occur as lenses of polymetallic massive sulphide that form at or near the seafloor in submarine volcanic environments, and are classified according to base metal content, gold content, or host-rock lithology.

They are discovered in submarine volcanic terranes that range in age from 3.4 Ga to actively forming deposits in modern seafloor environments. The most common feature among all types of VMS deposits is that they are formed in extensional tectonic settings, including both oceanic seafloor spreading and arc environments. Most ancient VMS deposits that are still preserved in the geological record formed mainly in oceanic and continental nascent-arc, rifted-arc, and back-arc settings.

Primitive bimodal mafic volcanic-dominated oceanic rifted arc and bimodal felsic-dominated siliciclastic continental back-arc terranes contain some of the world’s most economically important VMS districts. Most, but not all, significant VMS mining districts are defined by deposit clusters formed within rifts or calderas. Their clustering is further attributed to a common heat source that triggers large-scale sub-seafloor fluid convection systems. These sub-volcanic intrusions may also supply metals to the VMS hydrothermal systems through magmatic devolatilization.

As a result of large-scale fluid flow, VMS mining districts are commonly characterized by extensive semi-conformable zones of hydrothermal alteration that intensifies into zones of discordant alteration in the immediate footwall and hanging wall of individual deposits. VMS camps can be further characterized by the presence of thin, but very extensive, units of ferruginous chemical sediment formed from exhalation of fluids and distribution of hydrothermal particulates.

Franklin et al., (2005) classified the Noranda camp sequence as bimodal-mafic VMS type (see Figure 8-1). The Horne massive sulphide deposits are classified as anomalous because of their presence outside or on the margin of the Noranda Caldera and by the presence of numerous volcanoclastic sediments. The typical deposit lithologies and tectonic settings associated with bimodal-mafic VMS-type deposits are:

- Rifted bimodal volcanic arcs above intra-oceanic subduction (oceanic supra-subduction rift-arc);
- Basalt-dominant but with up to 25% felsic volcanic strata;

- Pillowed and massive volcanic flows, felsic flows, and predominant domes;
- Subordinate felsic and mafic volcanoclastic rocks;
- Sedimentary rocks are dominantly immature wacke, sandstone, and argillite with local debris flows;
- Hydrothermal chert common in the immediate hanging wall to some deposits.

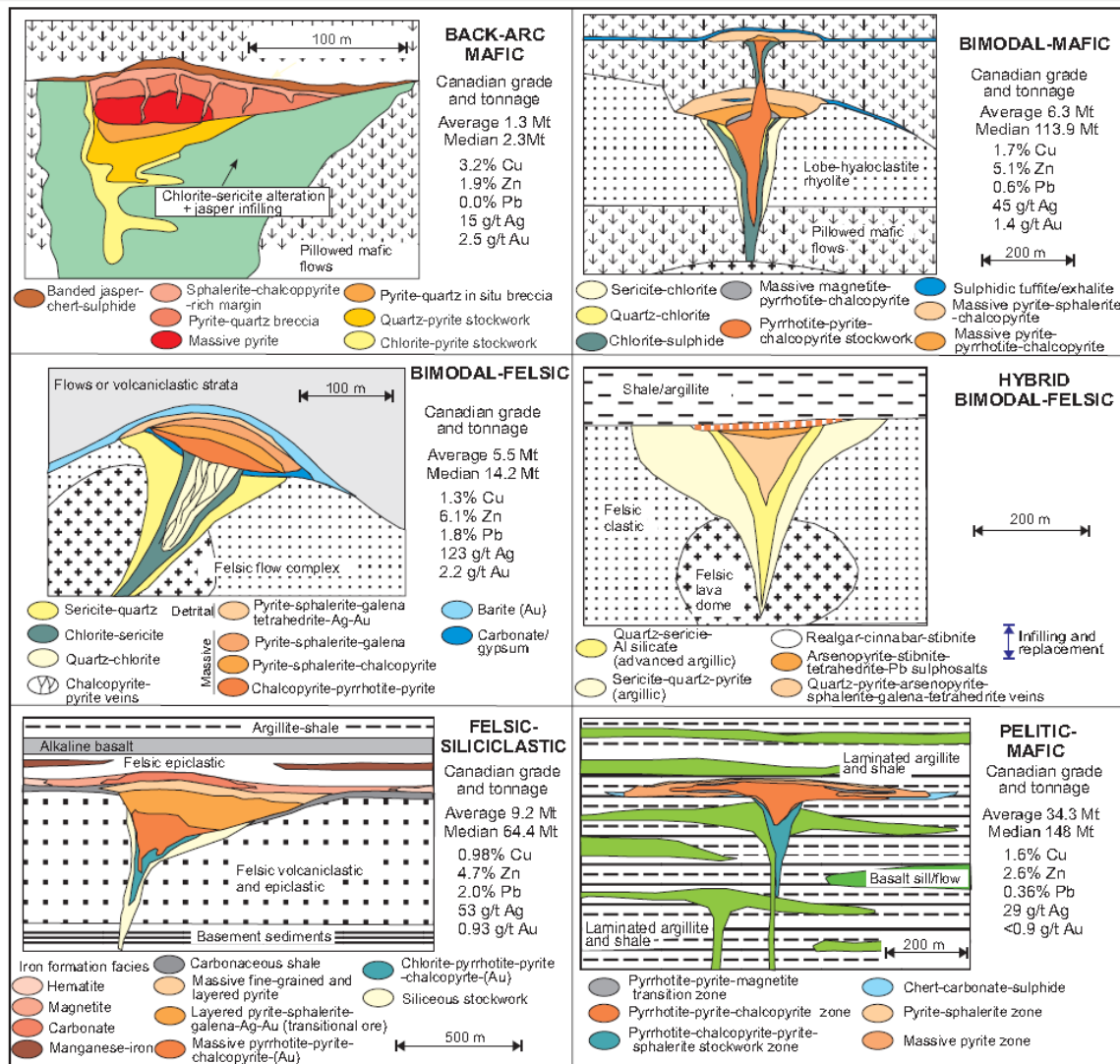

Figure 8-1: Graphic representation of the lithological classifications (Modified from Barrie and Hannington, 1999, by Franklin et al., 2005), with the addition of hybrid bimodal felsic as a VMS-epithermal subtype of bimodal-felsic. Average and median sizes for each type for representative Canadian deposits shown, along with average grade.

## 8.2 Gold-Rich Volcanogenic Massive Sulphide Deposits

The following description of the gold-rich volcanogenic massive sulphide (“Au-rich VMS”) deposits is summarized from Dubé et al. (2007) and Mercier-Langevin et al. (2010).

Au-rich VMS form a subtype of both volcanogenic massive sulphide and lode-gold deposits. Their diagnostic features are stratabound to discordant, volcanic-hosted massive sulphide lenses with associated discordant stockwork feeder zones in which average gold grades (in g/t) exceed associated combined copper, lead, and zinc grades (in weight percent; wt%); gold is thus the main commodity. Deposits with more than 3.46 g/t Au are considered Au-rich VMS. A large proportion of the total gold hosted in VMS worldwide is found in a relatively small number of such deposits.

Au-rich-VMS deposits are present in both recent seafloor and deformed and metamorphosed submarine volcanic settings. They occur in a variety of volcanic terranes from mafic bimodal through felsic bimodal to bimodal siliciclastic in greenstone belts of all ages, typically metamorphosed to greenschist and lower amphibolite facies, and intruded by sub-volcanic intrusions and dike-sill complexes. The deposits are commonly located in proximity to intermediate to felsic volcanic centres, at or close to the interface between intermediate to felsic volcanic domes and basalt-andesite or clastic sediments.

Several of the largest Au-rich VMS deposits are located in Canada: Horne, Bousquet 2-Dumagami, LaRonde Penna, and Eskay Creek. The first three deposits are hosted within the Archean Blake River Group, which is therefore an important geological assemblage for this style of gold deposit.

Sulphide minerals are mainly pyrite and base-metal sulphides with a complex assemblage of minor phases including bornite, tennantite, sulphosalts, arsenopyrite, mawsonite and tellurides. The distribution of gold within the deposit is most commonly uneven due to both primary depositional controls and subsequent tectonic remobilization.

At the district scale, Au-rich VMS deposits occupy a stratigraphic position and volcanic setting that commonly differs from other deposits of the district possibly due to an abrupt change in the geodynamic and magmatic evolution of local volcanic complexes. Au-rich VMS deposits are commonly associated with transitional to calc-alkaline intermediate to felsic volcanic rocks, which can reflect a particularly fertile geodynamic setting and/or timing (e.g., early arc rifting or rifting front).

There are two genetic models for Au-rich VMS: 1) conventional syngenetic volcanic-hosted Au-poor VMS mineralization overprinted during regional deformation by Au mineralization; and 2) syngenetic VMS deposits characterized by an anomalous fluid chemistry (with magmatic input) and/or deposition within a shallow-water to subaerial volcanic setting equivalent to epithermal conditions, in which boiling may have had a major impact on fluid chemistry. The deformation and metamorphism that commonly overprint the mineralization in ancient terranes have obscured the original relationships and led to considerable debate about the syntectonic versus synvolcanic origin of Au-rich VMS.

Depending on shape and depth, the sulphide contents of many of these deposits are sufficient to produce geophysical responses. Airborne and ground electromagnetic methods are effective at detecting massive sulphide mineralization but only where the sulphide grains are electrically connected. If they are not, they are, from an electromagnetic point of view, considered as disseminated sulphides, in which case they should be detectable by induced polarization surveys (Poulsen and Hannington, 1996).

### 8.3 Geological Characteristics of Au-rich VMS Deposits

The following description of the geological characteristics of Au-rich VMS deposits is summarized from Dubé et al. (2007).

The Horne deposit is the largest Canadian Au-rich VMS deposit in the Noranda district (331 tonnes of gold produced historically from 54.3 Mt of ore at 6.1 g/t Au; Kerr and Gibson, 1993).

The typical morphology of Au-rich VMS deposits consists of a lenticular massive sulphide body with associated underlying discordant stockwork-stringer feeders and replacement zones. At Horne, zones of auriferous sulphide veinlets with Fe-chlorite selvages account for some of the Au-rich mineralization (Kerr and Mason, 1990), however, the deposit lacks a well-defined stringer zone (Poulsen et al., 2000).

The vertical extent of the stockwork is typically larger than its lateral extent. The lateral extent of the deposit is typically a few hundred metres, but in some cases where the deposits are overturned, the mineralization has more than 2 km of known vertical extent (Horne and LaRonde Penna deposits). The thickness of the massive sulphide lenses is highly variable, especially when subjected to deformation (shortening), but is commonly about a few tens of metres.

Mineralization is typically hosted by felsic volcanic flows and volcanoclastic rocks (or their metamorphosed equivalents) near or at the interface with basaltic andesite, andesite or clastic sedimentary strata. The Horne deposit is contained within a fault-bounded block of tholeiitic rhyolite flows and pyroclastic breccia and tuffs in contact with andesite flows to the east. It is juxtaposed against andesite flows and a diorite intrusion to the south, and rhyolites to the north that contain the Quemont deposit, another auriferous massive sulphide deposit (Poulsen et al., 2000) potentially related to the same giant hydrothermal system responsible for the formation of the Horne deposit.

At the Horne deposit, most rhyolitic rocks within the fault-bounded block have been affected by weak sericitization and silicification that become more intense near the sulphide mineralization, where alteration is characterized by a quartz-sericite-pyrite assemblage (Poulsen et al., 2000). Chlorite alteration, which locally contains elevated copper and gold values, is largely restricted to the immediate footwall and sidewall of the deposit, except for local discordant zones in the footwall (Barrett et al., 1991).



## 9. EXPLORATION

Exploration work conducted by Falco included the compilation, digitization and integration of historical data. Following the first phase of the compilation work, which supported the April 2014 MRE, Falco integrated the following:

- Assay results from historical metallurgical tests;
- Additional historical drilling data;
- Assays results from historical underground channel samples,
- Geological information from historical underground drill holes.

This work was carried out from 2013 to 2016 and focused on the Horne 5 deposit, as well as the greater Horne 5 Complex area.

### 9.1 Assay Results from Historical Metallurgical Tests

Recent compilation work on the Horne 5 deposit uncovered paper copies of assay results from numerous metallurgical tests conducted between 1947 and 1963 on material from the Horne 5 deposit. Sampling intervals, sulphide content and assay results are available for 54 of the 76 bulk samples tested. The 54 bulk samples comprise more than 75,000 m of half-core from more than 2,100 DDH. For each bulk sample, the sulphide facies was either described as massive, disseminated or “miscellaneous”. Assay results for gold, silver, copper, zinc, iron and sulphur are available for every bulk sample. Assay results for Se and SiO<sub>2</sub> are available for 49 and 36 bulk samples, respectively. This information was integrated into the drill hole database.

Table 9-1 presents the average grade for the elements assayed for each of the 54 bulk samples of the historical metallurgical tests.

**Table 9-1: Average grade of the historical metallurgical tests (1946 to 1963)**

Au (g/t)	Ag (g/t)	Cu (%)	Zn (%)	Fe (%)	S (%)
1.28	15.91	0.15	0.86	21.44	21.84

Figure 9-1 illustrates the relationship between the silver and sulphur contents for the different sulphide facies. It shows that samples composed of disseminated sulphides generally contain less than 15% S (sulphur) and less than 12 g/t Ag (silver). It also shows that samples comprised of massive sulphides generally contain more than 30% S and more than 15 g/t Ag. This suggests a positive correlation between sulphide and silver contents.

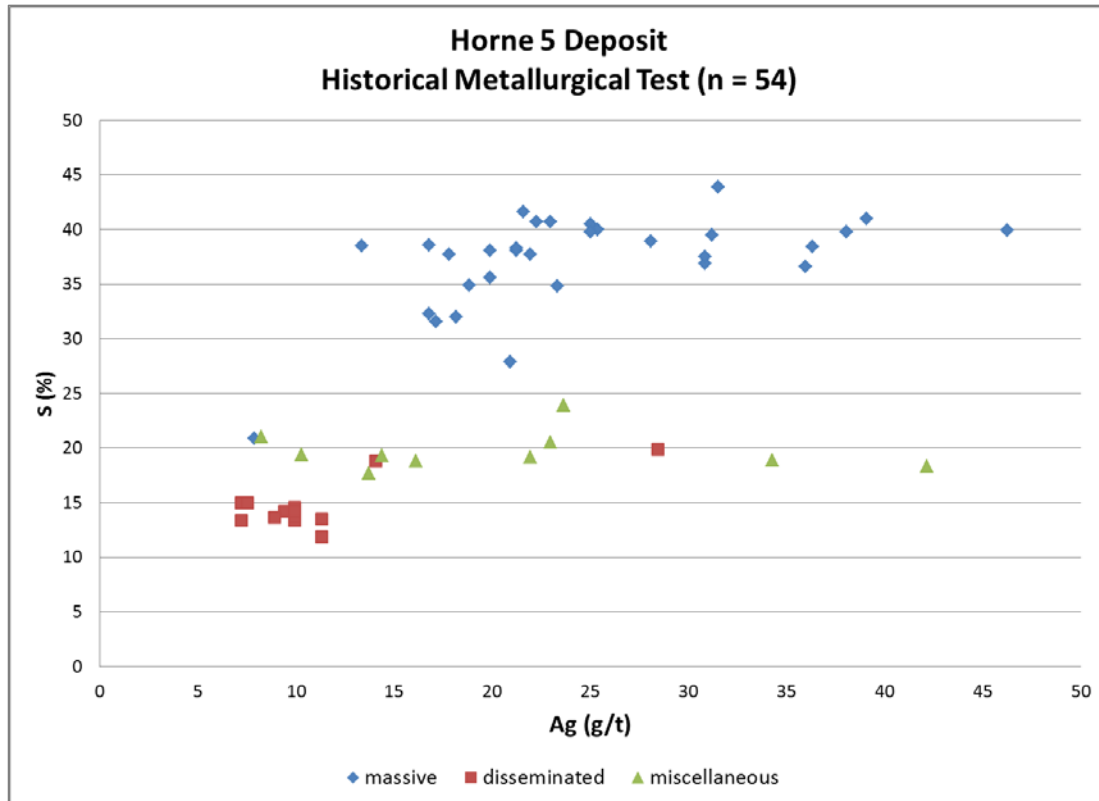

Figure 9-1: Relationship between silver and sulphur for the three sulphide facies

## 9.2 Additional Historical Drilling Data

In addition to the compilation work on the Horne 5 deposit, Falco continued to incorporate additional historical drilling data into the digital model from an area surrounding the Horne 5 deposit known as the Horne Complex. This included the areas immediately adjacent to the former producing Horne, Remnor, Quemont, Joliet and Chadbourne mines, as well as exploration targets within the Horne area, including Horne West and Gatehouse.

The data compilation exercise identified an additional 460,000 m of historical drilling in 6,600 holes drilled in the Horne Complex. A significant number of these holes were drilled in areas not previously mined, and include areas adjacent to the Horne 5 deposit. The digitization and compilation of these drill holes expanded the scope of the proprietary Horne model and provided additional exploration targets in close proximity to the Horne 5 deposit.

Eleven (11) new satellite gold zones were announced in Falco's news releases of July 10 and August 22, 2014 (refer to Table 9-2 and Table 9-3). An additional 16 new targets (Table 9-4) were announced in the news release of November 6, 2014, based on isolated historical drill unreported intercepts that had remained hidden in the archived drill database until Falco initiated its compilation study.

**Table 9-2: Highlights of historical drill results as announced in Falco's news release of July 10, 2014**

Target	Hole	From (metres)	To (metres)	Core Length <sup>(1)</sup> (metres)	Grades			
					Au (g/t)	Ag (g/t)	Cu (%)	Zn (%)
Zone STU	HN-33-9334	126.50	158.50	32.00	1.25	9.35	0.05	0.31
	HN-33-9339	88.40	103.60	15.20	5.04	14.47	0.08	1.47
	HN-33-9357	9.10	27.40	18.30	3.46	17.69	0.12	0.94
	HN-33-9369	227.70	269.70	40.00	6.16	11.34	0.16	0.75
	including	246.90	269.70	22.80	10.22	13.44	0.24	1.35
Zone 8670	HN-49-8670	597.40	610.20	12.80	0.46	NA	0.02	2.32
	HN-49-8670	606.60	615.70	9.10	1.85	NA	0.04	1.46
	including	606.60	608.20	1.60	1.03	28.46	0.04	11.30
Gatehouse	HN-07-4124	18.30	36.60	18.30	3.49	NA	TR	NA
	HN-09-1724	22.90	51.80	28.90	2.82	NA	NA	NA
	HN-09-1760	16.80	50.30	33.50	2.34	NA	0.57	NA
	HN-09-1740	50.30	51.80	1.50	100.11	NA	NA	NA
	HN-07-4103	56.40	57.90	1.50	11.66	NA	NA	NA
Zone M	HN-09-313	41.10	53.30	12.20	4.11	NA	NA	NA
	including	44.20	47.25	3.05	6.17	NA	NA	NA
Zone C	HN-09-305	42.70	76.20	33.50	2.52	NA	NA	NA
	including	42.67	47.20	4.53	4.34	NA	1.57	NA
	HN-09-364	64.01	67.01	3.05	10.29	NA	NA	NA

<sup>(1)</sup> All intercepts are reported as downhole lengths, not true thicknesses. Insufficient drilling has been completed to define the orientation of the mineralized zones in space.

Table 9-3: Highlights of historical drill results as announced in Falco’s news release of August 22, 2014

Target	Hole	From (metres)	To (metres)	Core Length <sup>(1)</sup> (metres)	Grades			
					Au (g/t)	Ag (g/t)	Cu (%)	Zn (%)
Lower West Zone	HN-21-2822	0.6	15.2	14.6	5.53	NA	Tr	NA
	HN-21-2845	4.5	16.8	12.2	4.29	NA	Tr	NA
	including	4.6	10.7	6.1	6.69	NA	NA	NA
	HN-21-2831	0.8	12.2	11.4	3.70	NA	Tr	NA
	HN-9-28	262.5	271.0	8.5	10.40	NA	NA	NA
	including	262.5	267.0	4.5	17.83	NA	NA	NA
	HN-21-2866 RN-9-28	1.5 163.0	3.0 163.8	1.5 0.5	24.00 17.83	NA NA	NA NA	NA NA
K Zone	HN-09-558	62.5	68.6	6.1	6.51	NA	NA	NA
	including	65.5	67.0	1.5	14.40	NA	NA	NA
AM Zone	HN-09-381	77.7	86.9	9.1	3.89	NA	NA	NA
	including	85.0	86.5	1.5	9.60	NA	NA	NA
	HN-09-281	56.0	59.0	10.0	5.49	NA	NA	NA
AA Zone	HN-49-4805	18.3	22.9	4.6	2.74	4.80	NA	NA
	Including	21.3	22.8	1.5	6.17	10.29	NA	NA
	HN-49-4817	12.2	24.4	12.2	2.06	25.80	TR	NA
	including	15.2	16.7	1.5	4.11	60.34	NA	NA
	HN-47-8676	3.0	24.0	21.0	2.87	NA	TR	TR
including	9.1	12.2	3.1	18.22	NA	TR	TR	
V Zone	HN-S-345	292.6	294.1	1.5	10.97	NA	NA	NA
	HN-S-345	416.0	419.0	3.0	5.49	NA	NA	NA
	HN-S-362	245.0	248.0	3.0	4.80	NA	NA	NA
Z Zone	HN-33-2929	189.0	190.5	1.5	8.91	NA	TR	NA
	HN-33-3312	45.5	47.0	1.5	6.17	NA	NA	NA

<sup>(1)</sup> All intercepts are reported as downhole lengths, not true thicknesses, from underground holes. Only the V Zone was drilled from surface. Insufficient drilling has been completed to define the orientation of the mineralized zones in space. The data is historical in nature and Falco has not independently verified the results; consequently, these results should not be relied upon.

Table 9-4: Highlights of historical drill results as announced in Falco’s news release of November 6, 2014

Mine Level	Hole	From (metres)	To (metres)	Core Length <sup>(1)</sup> (metres)	Grades			
					Au (g/t)	Ag (g/t)	Cu (%)	Zn (%)
Level 21	HN-21-5902	263.65	294.15	30.50	0.89	NA	NA	NA
	Including	266.70	274.32	7.62	1.37	NA	NA	NA
	HN-21-5902	475.49	487.68	12.19	1.88	NA	NA	NA
	Including	475.49	478.54	3.05	6.19	NA	NA	NA
	HN-21-5994	414.53	420.62	6.09	9.77	NA	NA	NA
	Including	419.10	420.62	1.52	32.91	NA	NA	NA
	HN-21-2885	533.40	553.21	19.81	1.13	NA	NA	NA
	Including	533.40	534.92	1.52	4.80	NA	NA	NA
	HN-21-6040	609.60	612.65	3.05	27.43	NA	NA	NA
HN-21-5892	6.07	9.12	3.05	28.11	NA	NA	NA	
HN-21-5892	647.70	650.75	3.05	5.49	NA	NA	NA	
Level 25	HN-25-1770	128.05	131.10	1.52	16.46	NA	NA	NA
Level 33	HN-33-8869	344.42	347.47	3.05	42.69	NA	NA	NA
	HN-33-4772	566.44	567.26	0.82	6.17	NA	NA	NA
Level 57	HN-57-9087	0.00	686.41	686.41	NA	NA	TR	TR
	Including	670.56	686.41	15.85	0.08	0.16	0.08	0.17
Level 65	HN-65-9068	67.05	70.10	3.05	14.74	NA	NA	NA
	HN-65-9068	496.82	505.97	9.15	31.54	NA	NA	NA
	HN-65-9068	568.45	574.55	6.10	1.71	NA	0.14	NA
	HN-65-9130	131.06	137.16	6.10	2.40	NA	NA	NA

<sup>(1)</sup> All intercepts are reported as downhole lengths, not true thicknesses, from underground holes. Insufficient drilling has been completed to define the orientation of the mineralized zones in space. The data is historical in nature and Falco has not independently verified the results; consequently, these results should not be relied upon.

### 9.3 Assay Results from Historical Underground Channel Samples

Channel samples were compiled and digitized by InnovExplo from the available historical plans presented in Noranda’s local mine grid system. Channel samples were documented for 23 of the 24 historical levels developed in the Horne 5 deposit.

Historically, two sets of plan views were produced based on historical underground channel sampling (Figure 9-2). This information was used in the development of a database.

The first set of historical plans (coloured) contains grade information expressed as ounces of gold per short ton (oz/st) (refer to Figure 9-2). The other set (black and white) contains grade information for gold expressed as dollars per short ton (USD/st), which corresponds to 20 times the oz/st values as 20 USD per short ton was historically used as the consensus price (Figure 9-2). For both sets, copper and zinc are expressed in percent (%). Silver, expressed in oz/st, was assayed only sparsely between levels 43 and 49, but continuously on levels 57 and 65. All channel sample data was converted to grams of gold and silver per tonne (g/t) (see Figure 9-3).

These plans constitute the only information supporting the construction of a channel sample database. No other supporting historical documents stored in the vault, such as laboratory certificates, sample lists, etc., were identified during the compilation. A historical plan showing underground channel sample information for level 57 was found after the database close-out date for the November 2016 MRE.

Where both are available, channel sample grades globally confirm drill hole results for all commodities. Channel samples were also collected continuously along drifts (Figure 9-2). Over the 14,799 compiled and digitized channel samples, 8,915 are associated with mineralized zones (Table 9-5 to Table 9-8).

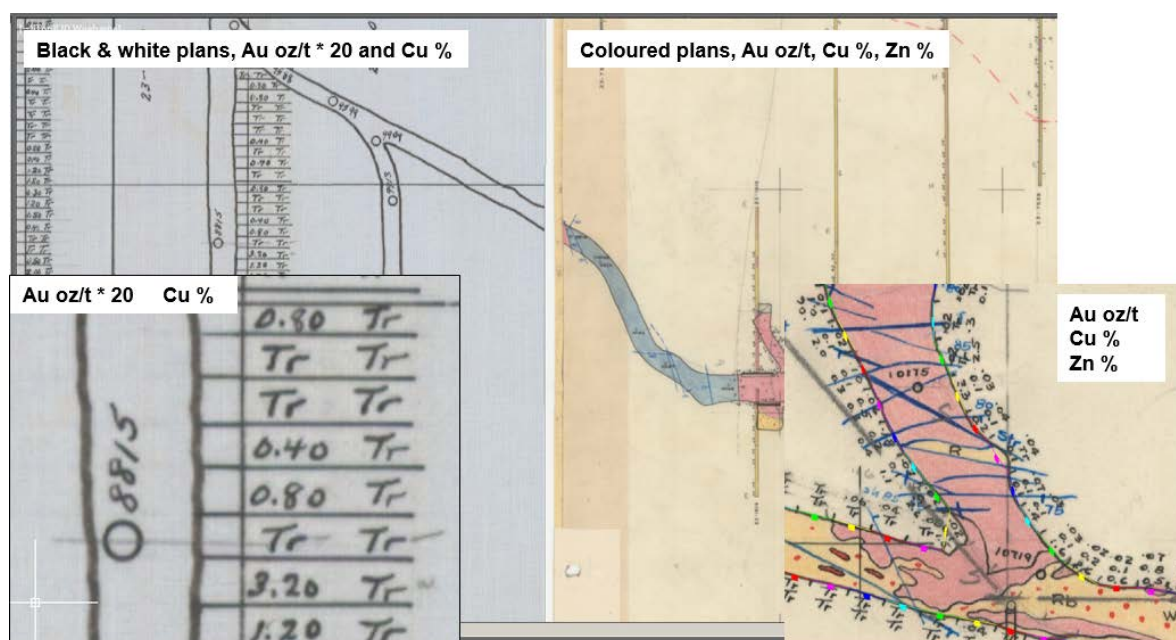

Figure 9-2: Examples of Noranda's historical plans (with close-ups)  
The recorded information was used to build a database of historical underground channel samples

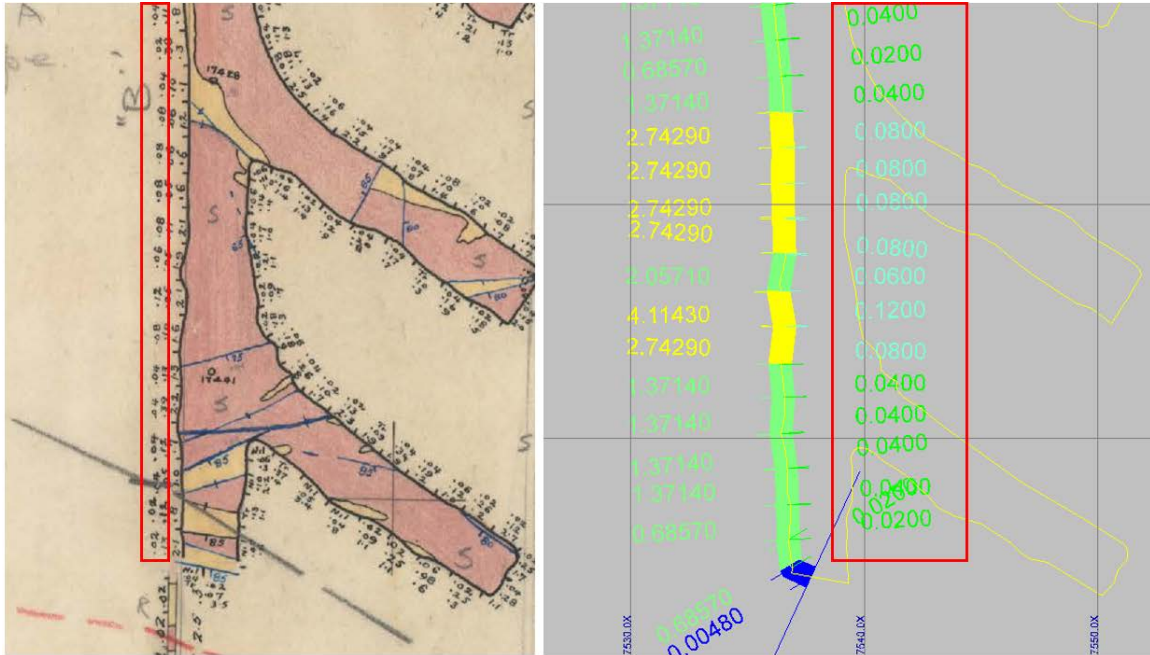

Figure 9-3: Example illustrating the conversion of historical gold values expressed as ounces per ton (oz/t) (red outline; left) to grams per tonne (g/t) (right)  
The conversion factor applied to historical underground channel samples was the same as that applied to historical underground drill holes



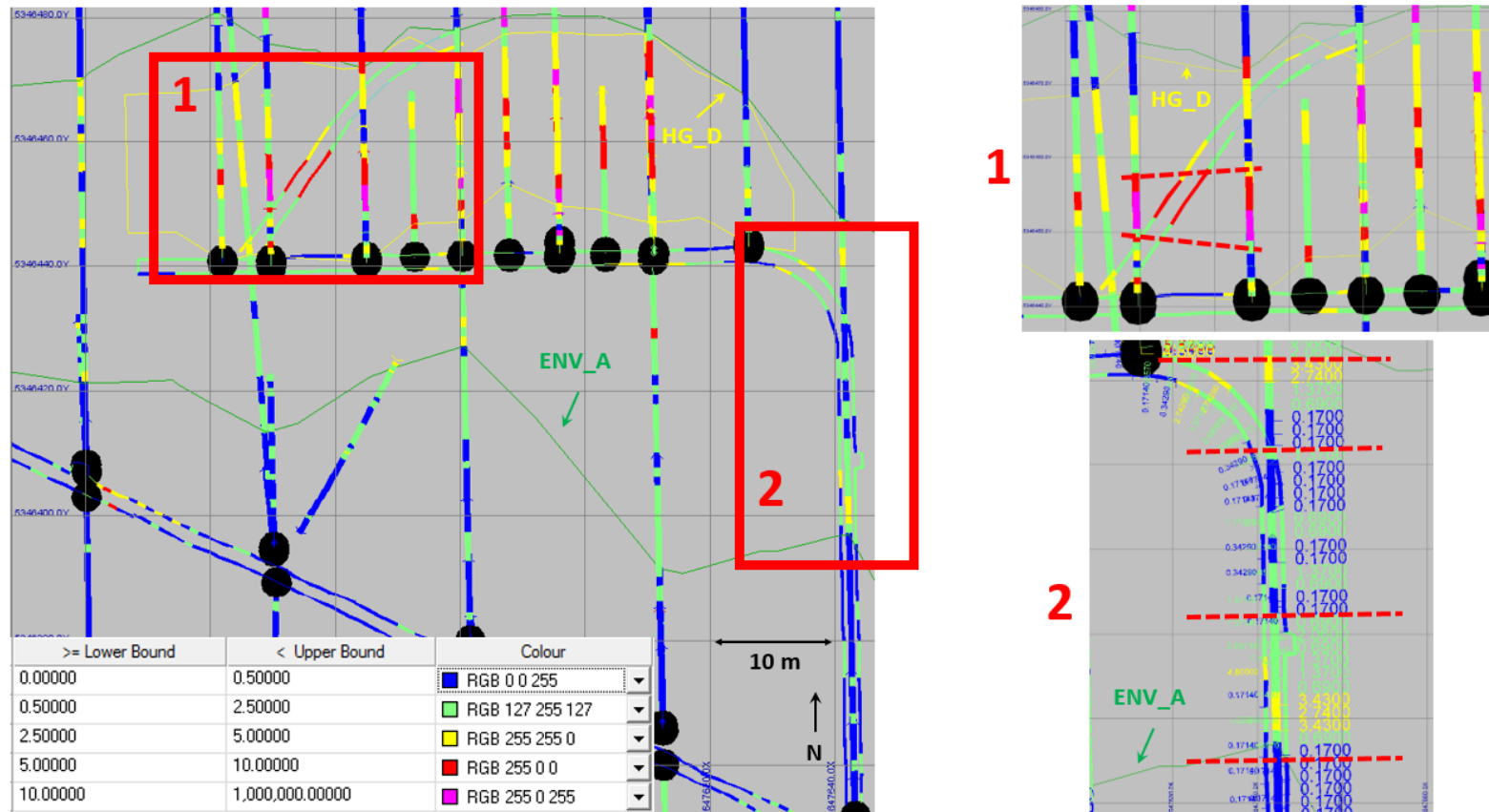

Figure 9-4: Plan view looking down on level 49 illustrating the relationship between gold grades in channel samples and those of nearby DDH (left) Close-up view #1 (top right) illustrates the correlation of high-grade gold values in the HG\_D mineralized zone. Close-up view #2 (bottom right) illustrates the correlation of low-grade gold values in the ENV\_A mineralized zone. Red dashed lines indicate correlations

Table 9-5 to Table 9-8 summarize the statistical analysis of channel samples by zone for each commodity.

**Table 9-5: Gold: Raw channel assays – summary statistics**

Zone	Block code	Number of samples	Mean Au (g/t)	COV	Min Au (g/t)	Max Au (g/t)	Number of samples assayed for Au	% samples assayed for Au
HG_A	110	728	2.08	1.14	0.01	28.11	711	97.66%
HG_B	120	1,374	2.07	2.69	0.01	123.43	1,360	98.98%
HG_C	130	174	5.07	2.16	0.17	84.34	162	93.10%
HG_D	140	39	2.71	0.72	0.17	7.89	35	89.74%
HG_E	150	200	4.18	2.44	0.01	128.23	197	98.50%
ENV_A	210	6,400	1.24	3.40	0.01	168.69	6,270	97.97%
<b>All Zones</b>		<b>8,915</b>			<b>0.01</b>	<b>168.69</b>	<b>8,735</b>	<b>97.98%</b>

**Table 9-6: Silver: Raw channel assays – summary statistics**

Zone	Block code	Number of samples	Mean Ag (g/t)	COV	Min Ag (g/t)	Max Ag (g/t)	Number of samples assayed for Ag	% Samples assayed for Ag
HG_A	110	728	-	-	-	-	-	-
HG_B	120	1,374	-	-	-	-	-	-
HG_C	130	174	17.61	2.17	0.17	155.66	29	16.67%
HG_D	140	39	23.56	0.45	6.86	47.66	28	71.79%
HG_E	150	200	-	-	-	-	-	-
ENV_A	210	6,400	7.30	0.90	0.17	21.26	20	0.31%
<b>All Zones</b>		<b>8,915</b>			<b>0.17</b>	<b>155.66</b>	<b>77</b>	<b>0.86%</b>

**Table 9-7: Copper: Raw channel assays – summary statistics**

Zone	Block code	Number of samples	Mean Cu (%)	COV	Min Cu (%)	Max Cu (%)	Number of samples assayed for Cu	% samples assayed for Cu
HG_A	110	728	0.10	2.24	0.005	2.30	707	97.12%
HG_B	120	1,374	0.15	2.44	0.002	5.60	1,360	98.98%
HG_C	130	174	0.14	1.39	0.005	1.20	171	98.28%
HG_D	140	39	0.27	0.77	0.010	0.86	35	89.74%
HG_E	150	200	0.40	1.50	0.005	3.00	158	79.00%
ENV_A	210	6,400	0.08	2.89	0.002	7.00	6,219	97.17%
<b>All Zones</b>		<b>8,915</b>			<b>0.002</b>	<b>7.00</b>	<b>8,650</b>	<b>97.03%</b>

Table 9-8: Zinc: Raw channel assays – summary statistics

Zone	Block code	Number of samples	Mean Zn (%)	COV	Min Zn (%)	Max Zn (%)	Number of samples assayed for Zn	% samples assayed for Zn
HG_A	110	728	1.08	1.30	0.005	10.70	154	21.15%
HG_B	120	1,374	0.89	1.00	0.005	5.20	453	32.97%
HG_C	130	174	0.09	2.06	0.005	1.30	129	74.14%
HG_D	140	39	0.97	1.09	0.030	4.44	35	89.74%
HG_E	150	200	0.20	1.13	0.100	0.90	22	11.00%
ENV_A	210	6,400	0.78	1.48	0.002	15.40	1,852	28.94%
<b>All Zones</b>		<b>8,915</b>			<b>0.002</b>	<b>15.40</b>	<b>2,645</b>	<b>29.67%</b>

#### 9.4 Geological Information from Historical Underground Drill Holes

In 2016, historical geological information was added to historical underground DDH in the current resource database. In all, geological information was added to 3,350 historical DDH in the database, which contains a total of 5,938 DDH used to delineate the Horne 5 deposit. This information will improve the accuracy of the lithostructural model and mineralized zones, and can be used to refine the following key parameters for future economic studies:

- Recovery – by more accurately estimating the contents of minerals other than pyrite in mineralized material;
- Comminution – by more accurately determining host rock to massive sulphide ratios, and providing better characterization of host rock types;
- Rock mechanics – by providing a more refined lithostructural model;
- Waste development – by more accurately estimating the sulphide content of development waste rock and, consequently, the acid generation potential of the material;
- Mineralized zones – by better defining mineralized zone geometries.

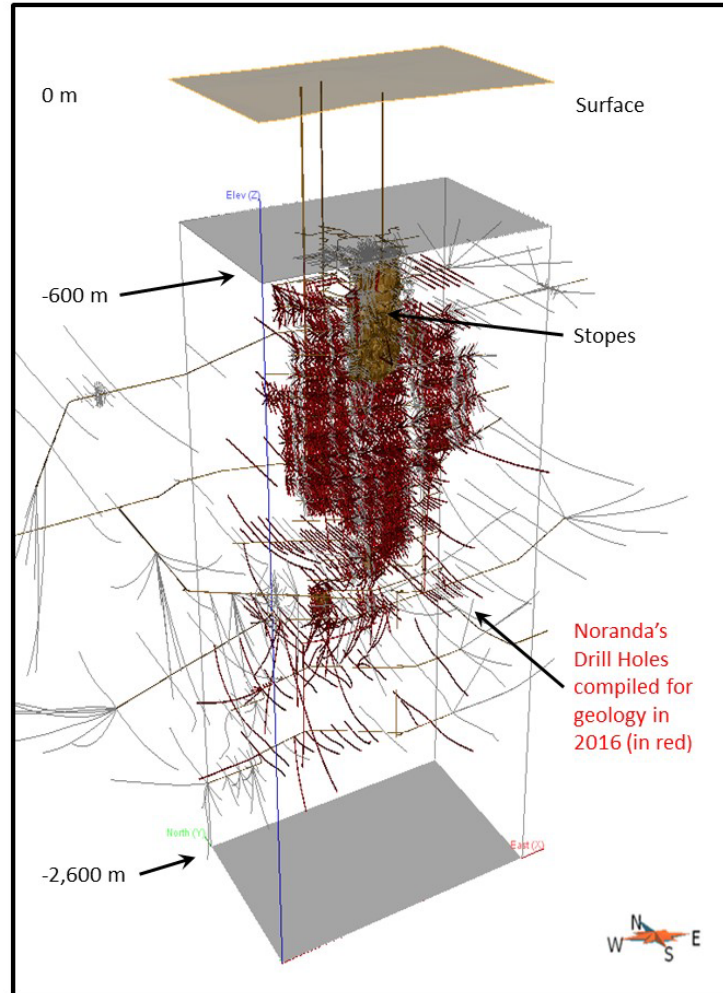

Figure 9-5: 3D view looking NE showing 3,350 Noranda DDH for which geological information was added to the database

#### 9.4.1 Data Acquisition

For each historical drill hole selected for the exercise, information about the following geological features was extracted from digitized historical logs (PDF format) (Figure 9-6):

- Lithologies;
- Mineralizations;
- Alterations;
- Structures;
- Veins.

Information was compiled in Excel spreadsheets according to historical vertical cross sections historically defined by Noranda using 15 m spacing.

The objective was to retain as much information as possible during the compilation so that any subsequent harmonization aiming to simplify or merge the geological information would not require re-examination of the original data.

### Lithologies

Each lithological occurrence was historically reported on logs according to contacts (Figure 9-6). In addition to lithologies, each interval of semi-massive and massive sulphide occurrence was mentioned as lithology by Noranda's geologists.

### Mineralization

Mineralization was described and quantified, in historical logs, for each assay footage in terms of mineral types and relative amounts (Figure 9-6). Pyrite was mentioned systematically as the primary type by Noranda geologists and its quantity was reported for one of eight levels (i.e., trace, well mineralized, heavy, massive, etc.). Other sulphides (e.g., chalcopyrite, pyrrhotite) or oxides (e.g., magnetite) were described as secondary types when observed in drill core.

### Alteration

Alteration was described for each assay footage by specifying the type, (e.g., chloritic, sericitic) or appearance (e.g., alteration, bleaching), along with the relative intensity (e.g., strong, moderate). Alteration generally straddles lithological contacts.

### Structures

Structures were reported for each footage in terms of type (e.g., fault, shear), relative intensity (e.g., strong, weak), and core angle, where possible. A significant number of structural occurrences were described within a wider or less intensely developed structure, usually shear zones. Core quality was also described (e.g., broken, ground).

### Veins

Vein occurrences were reported for each footage in terms of type (e.g., quartz, carbonate) and style (e.g., stringer, massive vein).

N-144-1-54-5M-SP

### DIAMOND DRILL RECORD

Hole No. 27-7390 Direction NORTH - SEC 900 E Location 27-10 DRIVE  
 Sheet No. 1 Date Begun May 4, 1965 Lat. \_\_\_\_\_ Dep. \_\_\_\_\_  
 Log Book No. \_\_\_\_\_ Dip +90° Bearing \_\_\_\_\_  
10° - 82°                      131° - 81°

Depth Feet	Sample No.	Gold Oz.	Cu %	Zn %	Fe %	S %	SiO <sub>2</sub> %	Averages	MINERALIZATION		Rocks	Contacts
									Quantity	Type		
0 - 2	Casing											
10	1468	nil.			9.8	1.8			Neg + g/	Pg	M	
20	69	01			9.0	.93			" " "	"	"	
30	70	Ti.			10.4	1.9		110'	" " "	"	"	
40	71	nil.			8.6	.62		Au .057	" " "	"	"	
50	72	Ti.			8.7	.62		Cu .08	" " "	"	"	
60	1491	.05	.08	<.5	7.9	3.0	47.0	Zn -	Neg g/ (wt)	Pg	M + RTg	Cont 56 <sup>3</sup>
70	92	.06	.05	<.5	4.9	3.6	71.3	Fe 9.5	g/ + W	Pg	RTg	
80	93	.32	.08	<.5	6.4	6.4	68.6	S. 5.4	g/ + W	Pg	RTg	
90	94	.08	.43	<.5	11.7	12.1	54.3		g/ + W	Pg	RTg	
100	95	.08	.17	<.5	9.0	9.3	62.9		g/ + W + Mass	Pg	RTg	Mass 93 <sup>6</sup> - 94 <sup>1</sup>
110	1533	.04	.17	<.5	18.8	19.6	46.6		g/ + W + Mass	Pg	RTg + Mass + RTg	Cont 106 <sup>1</sup> , 108 <sup>4</sup>
120	34	.02	.06	<.5	9.3	9.1	64.3		g/ + W	Pg	RTg	
131	35	.03	Ti.						g/	Pg	RTg + RTg	Change 123 <sup>2</sup>

↑ Sample footages

Mineralization quantity for the primary type

Mineralization Code for all types and associated quantity for secondary type

Litho Code

Lithological contacts

7390

Figure 9-6: Illustration of PDF log used for the compilation of geological information – DDH HN\_27-7390 - 1 page

## 9.4.2 Data Compilation

The data compilation routine for each geological feature comprised the following steps:

- Quality control and metric conversion;
- Harmonization of codes;
- Conversion of qualitative descriptions into digitally operable data.

### Quality Control and Metric Conversion

Various routines were run during data importation to prevent, for example, footage mishaps and drill hole mismatches. Footage was transformed into metric units and lithological information was added to the database (Figure 9-7).

### Harmonization of Codes

Several codes were merged according to the observed spatial correlations and continuities. Some codes were also merged due to the low number of occurrences. Harmonization was guided by a 3D review of geological information.

### Conversion of Qualitative Descriptions into Digitally Operable Data

A great deal of effort was made to establish a chart and convert Noranda's qualitative descriptions into operable data (i.e., percentages). The exercise also included a cross-reference operation between mineralization descriptions and the semi-massive to massive sulphide footages acquired from lithological descriptions.



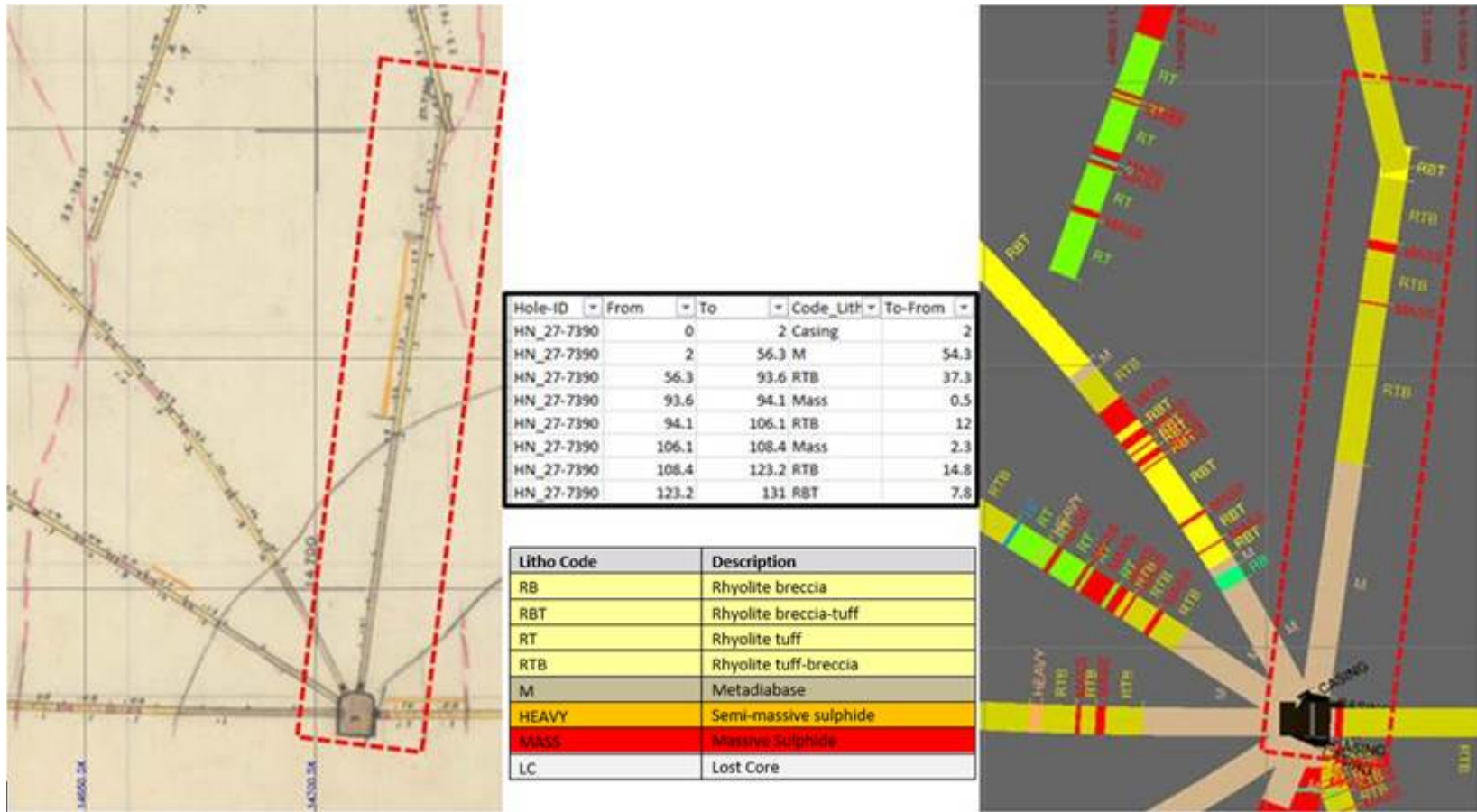

Figure 9-7: Transformation of geological historical information on Noranda vertical cross section (left) into Excel spreadsheet data (centre) and incorporation into the drill hole database (right)  
 DDH HN\_27-7390 is indicated by the red dashed outline

### 9.4.3 3D Modelling for Lithostructural Model

The previous lithostructural model (see Section 7.3.4) served as a basis for the 2016 lithostructural model. This previous model was updated and completed using the geological features acquired from the 3,350 historical underground drill holes and the 2015-2016 confirmation drilling

3D modelling was supported by implicit and explicit methods using gOcad and GEMS software.

The implicit method was used to establish lithological, alteration and mineralized domains in order to generate shells based on type, presence/intensity and quantity.

Structural domains, such as shear zones, were established the same way while structural panels, generated for primary and secondary fault systems, were generated from digitized lines honouring structurally relevant trends.

Lost-core footages, acquired from lithological descriptions, were used to create the structural panels.

The metadiabase (“Dyke M”) was constructed using the digitized Noranda geological interpretation on vertical cross sections (15 m spacing) supplemented by the 2016 compilation of geological drill hole information (Figure 9-8). Folding and dismembering of this metadiabase resulted in a complex shape that required the construction of several subdomains.

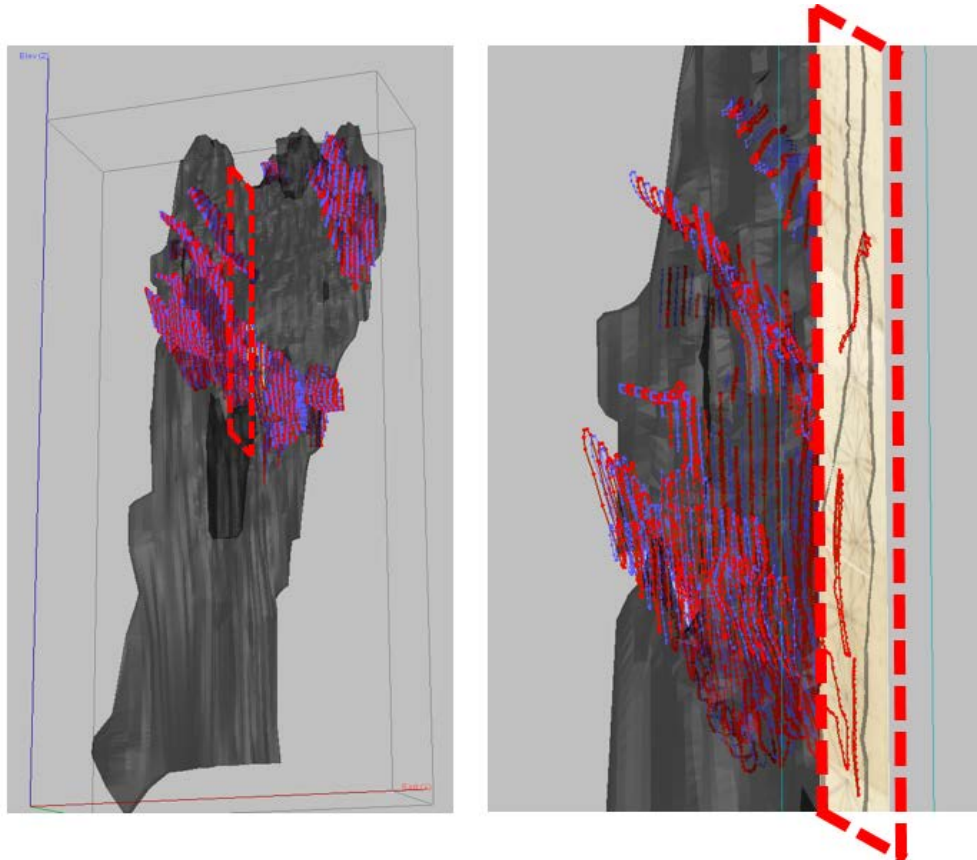

**Figure 9-8: 3D views of digitized lines used to form “Dyke M” domains**  
Relevant domains were digitized in the middle and upper portions of the Horne 5 deposit (right) according to historical information, which includes Noranda’s interpreted geology on vertical cross sections and the geology along drill holes (left)

## 10. DRILLING

### 10.1 Overview

In 2016, the drilling program on the Horne 5 deposit area comprised three phases for a planned total of 20,000 m. The first phase of 3,400 m consisted of a continuation of the confirmation and metallurgical drilling initiated in 2015, targeting the Horne 5 deposit itself. The second phase, for a planned total of 9,200 m, consisted of an exploration drilling program with the purpose of testing the western extension of the Horne 5 deposit, known as the Horne 5 West program. The third phase, totalling 5,000 m, consisted of an exploration drilling program with the purpose of testing proximal and distal extensions of known historical stopes on the Quemont Complex, known as the Quemont Extension program.

### 10.2 Confirmation / Metallurgical Drilling Program

The 2016 confirmation and metallurgical drilling program was planned for 3,300 m. Table 10-1 summarizes the statistics of the 2016 drilling program completed totalling 3,416 m. Figure 10-1 and Figure 10-2 show that the three drill holes were drilled from two set-ups.

Table 10-1: Summary statistics of the confirmation drilling program

Hole	Azimuth	Dip	Final Depth (m)	Length Drilled (m)	Metallic Assays	Whole Rock Assays
H5-16-17	192	-73	1,643	543	611	62
H5-16-18	167	-61	1,388	1,388	457	40
H5-16-07-D	138	-67	1,986	1,341	553	41
H5-16-09-Ctw	192	-67	1,269	144	136	None
<b>TOTAL</b>				<b>3,416</b>		





Figure 10-1: Location map of the confirmation drill holes realized in 2016 showing the projection of the main mineralized envelope (ENV\_A)

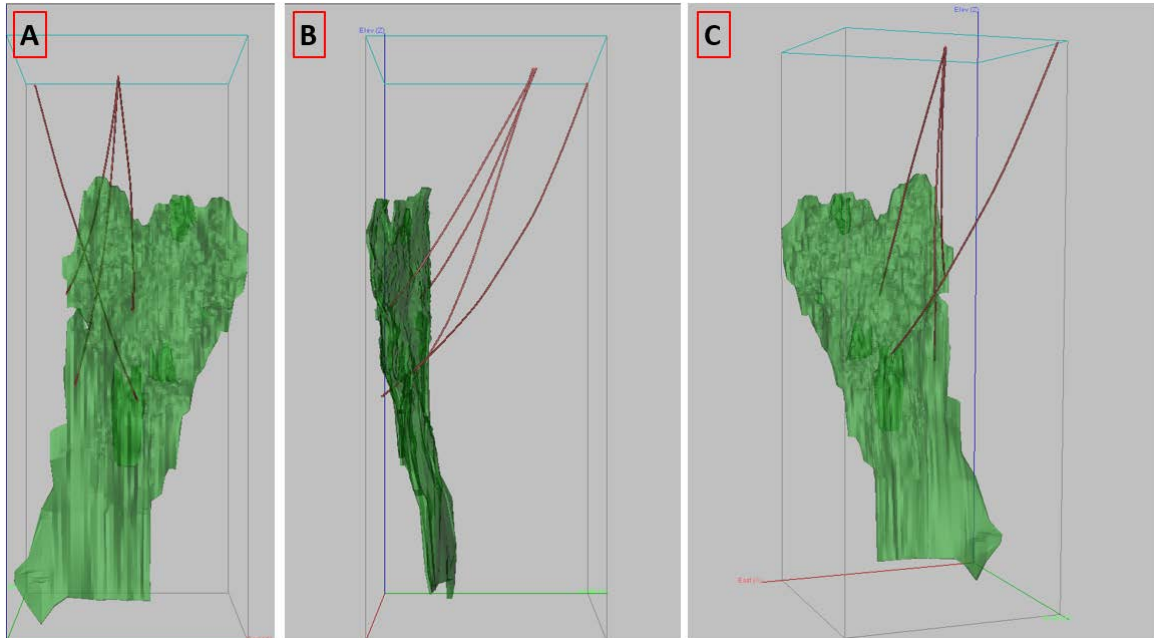

**Figure 10-2: Different views of confirmation drill holes that intersected the main mineralized envelope (ENV\_A)**  
**A) Composite longitudinal view looking north; B) Composite vertical section view looking west;**  
**C) 3D view looking southwest**

### 10.2.1 Assay Results

Drill holes H5-16-17, H5-16-18, H5-16-07-D and H5-16-09-Ctw intersected the main mineralized envelope (“ENV\_A”) of the Horne 5 deposit and confirmed the position and thickness of the mineralized zones.

Table 10-2 presents the assay results for the ENV\_A intersections and compares them to the weighted average of the raw assays from historical Noranda drilling. Drill hole H5-16-17 intercepted the Horne 5 deposit where no historical underground drill holes were intercepted by the 15-m-radius cylinder. For drill holes that have intercepted the Horne 5 deposit, where historical underground drill holes are available in their vicinity, grade variations are as follows:

- H5-16-18: Au 3.5%, Cu -22.2%, and Zn +53.8%;
- H5-16-07-D: Au 4.1%, Cu -33.3%, and Zn -36.2%;
- H5-16-09-Ctw: Au -4.0%, Cu -10.0%, and Zn +23.1%.

Using a price of 1,165 USD/oz for gold, 2.53 USD/lb for copper and 0.89 USD/lb for zinc, the gold-equivalent (“AuEq”) grade variation is respectively +8.1%, -17.8% and 2.14% for drill holes H5-16-18, H5-16-07-D and H5-16-09-Ctw.

Table 10-2: Assay results from the 2016 confirmation drilling program

Hole_ID	2016 Confirmation Drilling Results (Weighted average)								Weighted Average of Historical Raw Assays within a 15 m radius cylinder around DDH			
	From (m)	To (m)	Length (m)	Au (g/t)	Ag (g/t)	Cu (%)	Zn (%)	AuEq without silver (g/t)	Au (g/t)	Cu (%)	Zn (%)	AuEq without silver (g/t)
H5-16-17	1,516.9	1,550.5	33.6	2.16	46.41	0.40	0.87	3.21	n/a <sup>(1)</sup>	n/a <sup>(1)</sup>	n/a <sup>(1)</sup>	n/a <sup>(1)</sup>
H5-16-18	1,163.0	1,303.0	140.0	1.18	14.62	0.07	0.60	1.60	1.14	0.09	0.39	1.48
H5-16-07-D	1,795.3	1,933.4	138.1	0.71	8.69	0.10	0.44	1.09	0.74	0.15	0.69	1.32
H5-16-09-Ctw	1,173.5	1,214.2	40.7	1.44	25.19	0.18	1.44	2.46	1.5	0.2	1.17	2.41
									Comparison (%)			
H5-16-17	-	-	-	-	-	-	-	-	-	-	-	-
H5-16-18	-	-	-	-	-	-	-	-	3.50	22.20	53.80	8.10
H5-16-07-D	-	-	-	-	-	-	-	-	-4.05	-33.33	-36.23	-17.77
H5-16-09-Ctw	-	-	-	-	-	-	-	-	-4.00	-10.00	23.08	2.14

<sup>(1)</sup> Drill holes which have intercepted the Horne 5 Zone in an area where no historical drill holes were intercepted by the 15 m radius cylinder.



## 10.2.2 Lithological Units

Four main domains are encountered from north to south:

- A felsic flow domain (V1C to V1B), locally interlayered with diorites (I2J) and diabases (I3B);
- An intermediate to mafic domain (I2J to I3A or V2J);
- A felsic tuffaceous domain (T1), which hosts the mineralized facies (semi-massive to massive sulphides) and is interlayered in its northern part by a mafic unit (V3B);
- A mafic domain (V2J).

## 10.2.3 Alteration Facies

The main mineralized envelope (“ENV\_A”) is principally altered to silica, sericite, albite, magnetite and hematite. The alteration facies in the northern part of the zone are characterized mainly by silicification and hematization in the felsic flow units, and by chloritic alteration in the intermediate to mafic flow units. Intermediate to mafic intrusives host several metre-scale carbonatized intervals.

## 10.2.4 Structural Features

The major fault, known historically as the Horne Creek Fault, is located north of ENV\_A, and has been identified in the 2016 confirmation drill holes. Drill logs typically describe a strongly faulted interval ranging from several tens of centimetres to 20 m along the hole, hosted by a broad interval of heavily fractured rock ranging from several metres to 100 m along the hole. The presence of the fault is also supported by low Rock Quality Designation values (RQD <50) over intervals ranging from several tens of metres to 150 m along the hole.

The Andesite Fault, identified historically as the closest fault to the south of ENV\_A, was reported in the majority of confirmation drill holes. It presents as sheared and fractured multi-metre intervals (downhole length) characterized by low RQD (<50) values.

Other structural features encountered are fractured intervals, minor faults, folds, foliation and breccias, but these do not seem to signify the presence of other major structures.

### 10.2.5 Mineralized Facies

Drill logs identify several sulphide minerals in disseminated to massive facies. Pyrite is the most important in terms of presence and abundance. Pyrite is described over broad intervals, ranging in downhole length from tens of metres to 200 m, and ENV\_A corresponds to such a pyritic zone. ENV\_A ranges in downhole length from several tens of metres to over 100 m, and is characterized by semi-massive to massive sulphides (pyrite, chalcopyrite, sphalerite) containing metre-scale intervals of magnetite.

### 10.2.6 Litho geochemistry

A total of 143 samples were analyzed for major oxides, trace elements and rare earth elements. A preliminary report (Moore, 2016) presents the results by drill hole on composition discrimination diagrams, magmatic affinity and fractionation diagrams, and multi-element and rare-earth plots. It also provides mass balance calculations of major oxides plotted downhole.

## 10.3 Horne 5 West Program

The 2016 Horne 5 West drilling program was planned for 10,000 m. Table 10-3 summarizes the drilling statistics of the Horne 5 West exploration drilling program totalling 9,194 m. The objective of the program was to test the western extension of the Horne 5 deposit.

Table 10-3: Drilling statistics for the Horne 5 West exploration drilling program

Hole	Azimuth	Dip	Final Depth	Length Drilled	Metallic Assays	Whole Rock Assays
			(m)	(m)		
H5-16-09-D	192	-67	1,746	1,085	307	36
H5-16-09-E	192	-67	1,527	916	454	39
H5-16-09-F	192	-67	1,628	1,118	506	42
H5-16-17-A	192	-73	1,815	849	269	28
H5-16-17-B	195	-73	1,657	738	312	24
H5-16-17-C	194	-73	1,860	1,083	397	35
H5-16-19	202	-59	1,416	1,416	555	39
H5-16-23	217	-68	1,989	1,989	688	52
<b>TOTAL</b>				<b>9,194</b>		

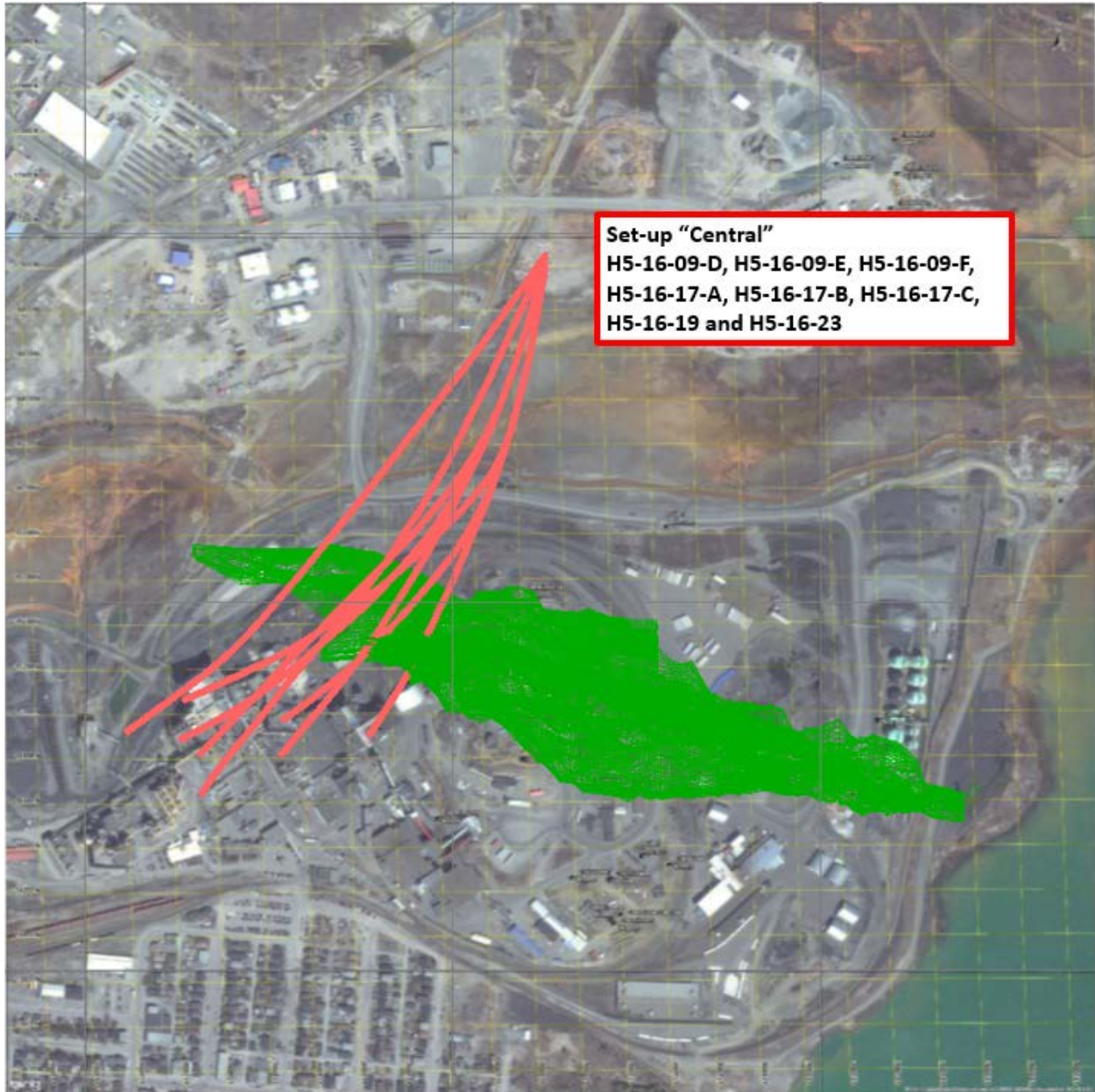

Figure 10-3: Location map of the drill hole from the Horne 5 West Program realized in 2016 showing the projection of the main mineralized envelope (ENV\_A)

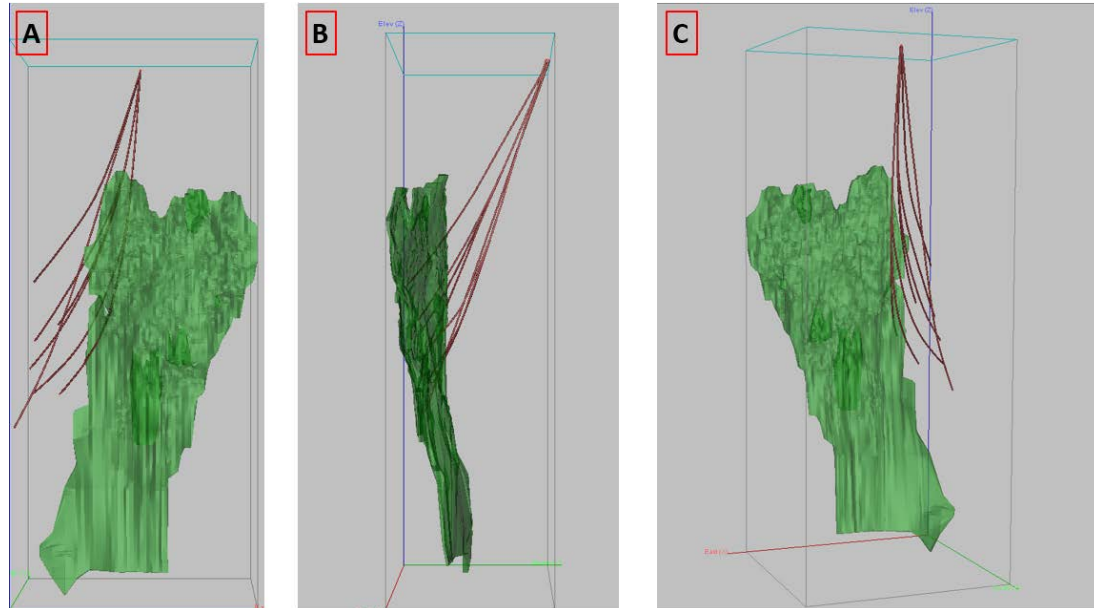

Figure 10-4: Different views of the drill holes from the Horne 5 West Program  
A) Composite longitudinal view looking north; B) Composite vertical section view looking west;  
C) 3D view looking southwest.

### 10.3.1 Assay Results

Drill holes H5-16-17-A and H5-16-09-E slightly extended the main mineralized system (from 5 m to 15 m) of the Horne 5 deposit on its western side. Drill hole H5-16-17-B intersected ENV\_A of the Horne 5 deposit and confirmed the position and thickness of the mineralized zones. Drill holes H5-16-09-D, H5-16-09-F, H5-16-17-C, H5-16-19 and H5-16-23 did not intersect the main mineralized system at the expected depth. However, a mineralized zone was intercepted 200 m south of the projected extension of the Horne 5 deposit. Further exploration work will be required to confirm if it is a parallel zone to Horne 5 or if it is the Horne 5 displaced by a fault.

Table 10-4 presents the assay results for the mineralized intersections resulting from the 2016 Horne 5 West drilling program. No historical underground drill holes were realized in this area and do not allowed any comparison. Grade results are as follows:

- H5-16-17-A: 3.02 g/t Au, 52.18 g/t Ag, 0.29% Cu and 1.77% Zinc over 12.4 m (from 1,570.0 m to 1,582.4 m). The ENV\_A intersection for silver yielded 37.69 g/t Ag when a capping value of 110 g/t Ag was applied. For silver, refer to Chapter 14 – Mineral Resource Estimate for the capping value applied in the ENV\_A for the purpose of the mineral resource estimate;

- H5-16-09-E: 1.26 g/t Au, 26.82 g/t Ag, 0.21% Cu, and 1.41% Zn over 9.9 m (from 1,208.0 m to 1,217.9 m);
- H5-16-17-B: 1.21 g/t Au, 23.16 g/t Ag, 0.16% Cu, and 2.79% Zn over 32.0 m (from 1,461.0 m to 1,493.0 m)

Using a price of 1,165 USD/oz for gold, 2.53 USD/lb for copper and 0.89 USD/lb for zinc, the AuEq is respectively 4.38, 2.31 and 2.91 for drill holes H5-16-17-A, H5-16-09-E and H5-16-17-B.

As shown on Figure 10-5, drill hole H5-16-17-A was used for the October 2017 MRE and slightly extended the main mineralized envelope (ENV\_A) by about 10 m laterally and close to 50 m vertically.

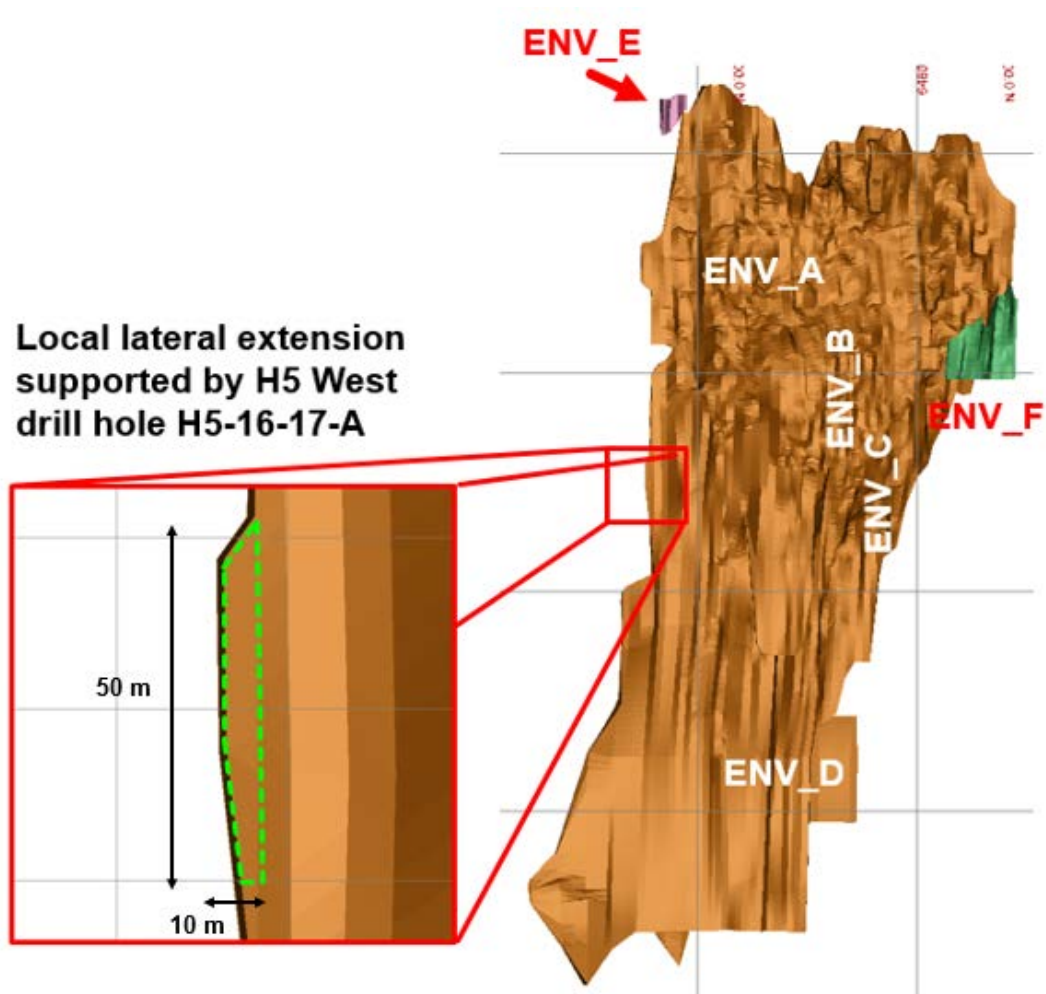

Figure 10-5: Composite longitudinal view and close-up view of slight extension of ENV\_A based on results from drill hole H5-16-17-A



Table 10-4: Assay results from the 2016 Horne 5 West drilling program

Hole_ID	2016 Horne 5 West Drilling Results (Weighted average)								Weighted Average of Historical Raw Assays within a 15 m radius cylinder around DDH			
	From (m)	To (m)	Length (m)	Au (g/t)	Ag (g/t)	Cu (%)	Zn (%)	AuEq without Ag (g/t)	Au (g/t)	Cu (%)	Zn (%)	AuEq without Ag (g/t)
H5-16-17-A	1570.0	1582.4	12.4	3.02	52.18	0.29	1.77	4.38	n/a <sup>(1)</sup>	n/a <sup>(1)</sup>	n/a <sup>(1)</sup>	n/a <sup>(1)</sup>
H5-16-09-D	Western extension of Horne 5 mineralized system not intersected											
H5-16-09-E	1208.0	1217.9	9.9	1.26	26.82	0.21	1.41	2.31	n/a <sup>(1)</sup>	n/a <sup>(1)</sup>	n/a <sup>(1)</sup>	n/a <sup>(1)</sup>
H5-16-09-F	Western extension of Horne 5 mineralized system not intersected											
H5-16-17-B	1461.0	1493.0	32.0	1.21	23.16	0.16	2.79	2.91	n/a <sup>(1)</sup>	n/a <sup>(1)</sup>	n/a <sup>(1)</sup>	n/a <sup>(1)</sup>
H5-16-17-C	Western extension of Horne 5 mineralized system not intersected											
H5-16-19	Western extension of Horne 5 mineralized system not intersected											
H5-16-23	Western extension of Horne 5 mineralized system not intersected											
									<b>Comparison (%) - n/a<sup>(1)</sup></b>			

<sup>(1)</sup> Drill holes which have intercepted the Horne 5 Zone or mineralized system in an area where no historical drill holes were intercepted by the 15 m radius cylinder.

## 10.4 Quemont Extension Program

The 2016 Quemont Extension drilling program was planned for 6,700 m. Table 10-4 summarizes the drilling statistics of the Quemont Extension drilling program totalling 5,066 m. The objective of the program was to test the proximal and distal extensions of known historical stopes belonging to the Quemont Complex.

Despite of the completion of assaying results from the Quemont Extension program, this drilling program is beyond the mineral resources estimate area and exposed results are not relevant for the purpose of this Report.

Table 10-5: Summary of drilling statistics of the Quemont Extension drilling program

Hole	Azimuth	Dip	Final Depth (m)	Length Drilled (m)	Metallic Assays	Whole Rock Assays
H5-16-20	128	-66	1,231	1,231	269	37
H5-16-20-A	128	-66	1,536	975	564	31
H5-16-21	150	-73	1,575	1,575	379	49
H5-16-22	128	-51	1,285	1,285	385	32
<b>TOTAL</b>				<b>5,066</b>		



## 11. SAMPLE PREPARATION, ANALYSES, AND SECURITY

The results of confirmation and exploration drilling programs conducted by Falco in 2015 and 2016 were used for the October 2017 MRE. InnovExplo reviewed the following aspects related to these campaigns: laboratory accreditation and certification, sample preparation descriptions, analytical method descriptions, and quality assurance / quality control (“QA/QC”) protocols.

### 11.1 Laboratory Accreditation and Certification

The International Organization for Standardization (“IOS”) and the International Electrotechnical Commission (“IEC”) form the specialized system for worldwide standardization. ISO/IEC 17025 General Requirements for the Competence of Testing and Calibration Laboratories sets out the criteria for laboratories wanting to demonstrate they are technically competent, they operate an effective quality system, and they are able to generate technically valid calibration and test results. The standard forms the basis for the accreditation of competence of laboratories by accreditation bodies. ISO 9001 applies to management support, procedures, internal audits and corrective actions. It provides a framework for existing quality functions and procedures.

The sample preparation and assaying facility at ALS Chemex in Val-d’Or (Québec) was used for the 2015 drilling campaigns. The 2016 drilling campaigns used the sample preparation and assaying facilities at Activation Laboratories Ltd. (“Actlabs”) in Sainte-Germaine-Boulé (Québec). Both laboratories are accredited ISO/IEC 17025 and ISO 9001.

### 11.2 Sample Preparation

The drill core is boxed, covered and sealed at the drill rigs, and transported by the drilling personnel to the logging facility of Services Technominex Inc. (“Technominex”) in Rouyn-Noranda (Québec) where Technominex personnel take over the core handling. Technominex is a mining exploration service company based in Rouyn-Noranda. The core is logged and sampled by Technominex’s geologists. Core sample length varies from 0.4 m to 1.1 m. Within mineralized zones, core samples generally do not exceed 1 m. Each core sample is tagged with a unique number.

Falco has implemented a strict quality control program to comply with best practices in the sampling and analysis of drill core. As part of its QA/QC program, Falco inserts external certified mineralized standards. In 2015, each shipment batch from a mineralized zone contained 27 samples consisting of 23 core samples and four QA/QC samples to test the laboratory’s analytical methods and precision: a certified standard, a blank, a pulp duplicate, and a reject duplicate placed randomly every 15<sup>th</sup> sample. In 2016, each shipped batch from a mineralized zone contained 20 samples consisting of 17 core samples and three QA/QC samples: a certified standard, a blank, and a coarse duplicate. Blanks and standards are inserted within the normal

sample number sequence, whereas the duplicate is added at the end of the batch. Assay results and certificates of analysis are interpreted and reported on a regular basis. If anomalies are detected, the laboratory is advised and the entire batch of samples is re-assayed. In 2015, each shipped batch from a non-mineralized zone contained 27 samples, and in 2016, batches contained 20 samples; in both years, batches included one standard and one blank. If anomalies are detected for batches in non-mineralized zones, the laboratory is advised, but the batch is not necessarily re-assayed.

### 11.3 Sample Preparation (Non-mineralized Zones)

The following sample preparation protocol applies to samples collected in non-mineralized zones.

In 2015, at ALS Chemex, the sample was logged in the tracking system, weighed, dried and finely crushed to better than 70% passing a 2 mm screen (Tyler 9 mesh, US Std No.10). A split of up to 250 g was taken and pulverized to better than 85% passing a 75 micron screen (Tyler 200 mesh, US Std No. 200).

In 2016, at Actlabs, the sample was logged, weighed, dried and finely crushed to better than 80% passing a 1.7 mm screen (Tyler 10 mesh, US Std No. 12). A split of up to 250 g was taken and pulverized to better than 80% passing a 75 micron screen (Tyler 200 mesh, US Std No. 200).

### 11.4 Sample Preparation (Mineralized Zones)

The following sample preparation protocol applies to samples collected from known mineralized zones.

In 2015, at ALS Chemex, the sample was logged in the tracking system, weighed, dried and finely crushed to better than 70% passing a 2 mm screen (Tyler 9 mesh, US Std No. 10). A split of up to 1,000 g was taken using a Boyd rotary splitter and pulverized to better than 85% passing a 75 micron screen (Tyler 200 mesh, US Std No. 200).

In 2016, at Actlabs, the sample was logged, weighed, dried and finely crushed to better than 80% passing a 1.7 mm screen (Tyler 10 mesh, US Std No. 12). At the request of Falco, a supplementary cleaning of the crusher was done. A split of up to 1000 g was taken and pulverized to better than 80% passing a 75 micron screen (Tyler 200 mesh, US Std No. 200).

## 11.5 Analytical Methods

In 2015 and 2016, the specific gravity of samples collected from known mineralized zones was determined by weighing the sample in air and water, or occasionally by using a pycnometer on pulps.

In 2015 and 2016, samples were analyzed by the fire assay technique. The technique used high temperature and flux to melt a 30-g aliquot of a powdered sample, allowing the gold to be collected. A tiny silver bead containing gold can be dissolved and analyzed by atomic absorption ("AA"). The concentration is normally expressed as parts per million ("ppm"), which is equivalent to grams per tonne ("g/t").

At the request of Falco, any sample assaying >5 g/t Au with AA finish was rerun with gravimetric finish. Aqua regia is a powerful solvent for sulphides that dissolves silver and base metals. Samples containing silver, copper and zinc are dissolved using aqua regia and assayed by ICP-OES. The minimum sample size is 1 g for this analytical method.

At the request of Falco, any sample assaying 10,000 ppm Cu or Zn (upper limit of the analytical method) with AA finish was rerun in order to obtain the assay results in percentage. The minimum sample size is then 0.5 g for this analytical method.

## 11.6 Falco QA/QC Results for the 2015–2016 Diamond Drilling Programs

The next sections present the QA/QC results from holes drilled during the 2015–2016 programs, which are included in the October 2017 MRE database.

### 11.6.1 Blanks

The field blank used for the 2015–2016 programs was a crushed sample of gold-barren marble. One field blank was inserted for every 27 field samples in 2015, and one field blank was inserted for every 20 field samples in 2016.

Falco's quality control protocol stipulates that if any blank yields a gold value above 0.05 g/t Au (10x detection limit), a silver value above 1 g/t Ag (5x detection limit), a copper value above 100 ppm Cu (100x detection limit) or a zinc value above 100 ppm Zn (100x detection limit), then all samples assayed at the same time as the blank should be re-analyzed if significant assay values were obtained in the other samples.

A total of 400 blanks were assayed by ALS Chemex in 2015, and 80 blanks were assayed by Actlabs in 2016.

In 2015, 18 blanks failed Falco's quality control procedure for at least one element, representing 4.5% of all blanks. Of these 18, six were re-analyzed at the request of Technominex's geologists.

In 2016, eight blanks failed Falco's quality control procedure for at least one element, representing 10% of all blanks. Of these eight, one was re-analyzed at the request of Technominex's geologists.

InnovExplo believes that Falco's quality control results for blanks from the 2015–2016 drilling programs are reliable and valid.

### 11.6.2 Certified Reference Materials (Standards)

For the 2015 drilling program, one certified reference material ("CRM") was inserted for every 27 samples. The assigned grades for the eight different standards used for the drilling program are presented in Table 11-1.

For the drilling program performed in 2016, one CRM was inserted for every 20 samples. The assigned grades for the eight different standards used for the drilling program are presented in Table 11-2.

Table 11-1: Standards used by Falco for the 2015 drilling program  
(drill holes used in the October 2017 MRE)

Standard (CRM)	Standard Supplier	Certified Au Value (g/t)	Standard Deviation (Au)	Certified Ag Value (g/t)	Standard Deviation (Ag)	Certified Cu Value (%)	Standard Deviation (Cu)	Certified Zn Value (%)	Standard Deviation (Zn)
OREAS 10c	Ore Research and Exploration PTY Ltd	6.60	0.160						
OREAS 15d	Ore Research and Exploration PTY Ltd	1.56	0.042						
OREAS 61e	Ore Research and Exploration P/L	4.51	0.260	5.37	0.380				
OREAS 62e	Ore Research and Exploration P/L	9.37	0.620	9.86	0.370				
OREAS 620	Ore Research and Exploration P/L	0.69	0.021	38.50	1.530	0.17	0.004	3.15	0.097
OREAS 621	Ore Research and Exploration P/L	1.25	0.042	69.00	2.700	0.36	0.008	5.22	0.139
OREAS 623	Ore Research and Exploration P/L	0.83	0.039	20.40	1.060	1.73	0.004	1.03	0.030
OREAS 624	Ore Research and Exploration P/L	1.16	0.053	45.30	1.260	3.10	0.079	2.40	0.078

Table 11-2: Standards used by Falco for the 2016 drilling program  
(drill holes used in the October 2017 MRE)

Standard (CRM)	Standard Supplier	Certified Au Value (g/t)	Standard Deviation (Au)	Certified Ag Value (g/t)	Standard Deviation (Ag)	Certified Cu Value (%)	Standard Deviation (Cu)	Certified Zn Value (%)	Standard Deviation (Zn)
OREAS 202	Ore Research and Exploration P/L	0.75	0.026						
OREAS 206	Ore Research and Exploration P/L	2.20	0.081						
OREAS 61e	Ore Research and Exploration P/L	4.51	0.260	5.37	0.380				
OREAS 621	Ore Research and Exploration P/L	1.25	0.042	69.00	2.700	0.36	0.008	5.22	0.139
OREAS 623	Ore Research and Exploration P/L	0.83	0.039	20.40	1.060	1.73	0.004	1.03	0.030

The accuracy of each result (as a percentage) is measured as the difference between the average of the assays for the standard and the value assigned for the standard (excluding gross outlier values). For a laboratory, good accuracy constitutes the ability to obtain results as near as possible to the expected value (as a percentage near 0%). The precision of the result (as a percentage) is represented by the dispersion of the assay results for the standard versus their average. For a laboratory, good precision constitutes the ability to repeat results with the smallest standard deviation possible (as a percentage near 0%). The difference between accuracy and precision is illustrated in Figure 11-1.

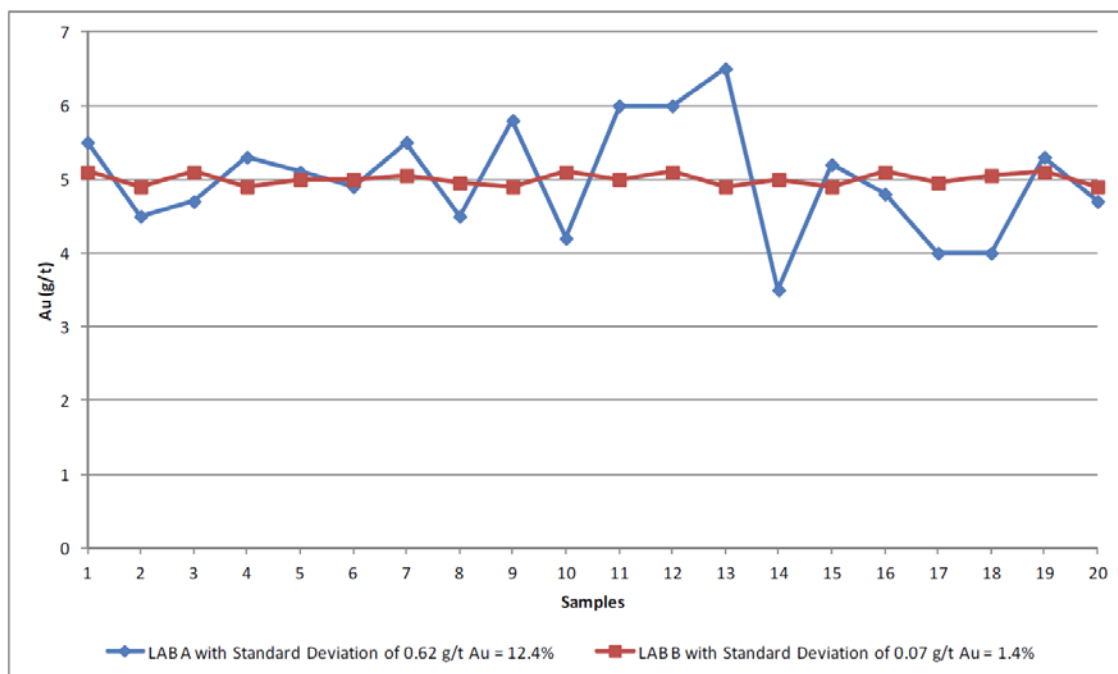

Figure 11-1: Difference between accuracy and precision

Lab A and Lab B have analyzed the same standard with a grade of 5.0 g/t Au using the same number of samples (n=20) to produce the same final average (5.0 g/t Au). Accuracy is perfect (0%) for both, but the precision of Lab B is better (1.4%) than the precision of Lab A (12.4%).

Falco's quality control protocol stipulates that any standard yielding gold, silver, copper or zinc values beyond three standard deviations (see Table 11-1) is considered a fail. Only samples of mineralized zone material should be re-analyzed in the case of a failed standard. In such cases, if there are no significant gold, silver, copper or zinc results within the batch of 27 samples in 2015, or the batch of 20 samples in 2016, no re-assay is ordered.

In 2015, a total of 394 standards were assayed at ALS Chemex during the 2015 drilling program. Thirty-three (33) standards failed Falco's quality control procedure for at least one element, representing 8.38% of standards. Among these 33 standards, 27 were re-analyzed as requested by Technominex geologists.

In 2016, a total of 66 standards were assayed at Actlabs during the 2016 drilling program in holes H5-16-17, H5-16-17A and H5-16-18. Eighteen (18) standards failed Falco's quality control procedure on at least one element, representing 27.2% of standards. Among these 18 standards, 4 were re-analyzed at the request of Technominex's geologists.

InnovExplo believes that Falco's quality control results obtained for standards from the 2015–2016 drilling programs are reliable and valid.

### 11.6.3 Duplicates

Duplicates are used to check the representativeness of results obtained for a given population. To determine reproducibility, precision (as a percentage) is calculated according to the following formula:

$$\text{Precision (\%)} = \frac{(\text{Duplicate Sample Gold Grade} - \text{Original Sample Gold Grade})}{\text{Average between Duplicate Sample Gold Grade and Original Sample Gold Grade}} \times 100$$

Precision ranges from 0% to 200%, with the best being 0% (meaning that both the original and the duplicate samples returned the same grade).

#### Pulp Duplicates

At the request of Falco personnel, the laboratory assayed one pulp duplicate for every 27 samples in 2015 and every 20 samples in 2016. The precision of pulp duplicates can be used to determine the incremental loss of precision for the pulp pulverizing stage of the process, thereby establishing whether a given pulp size taken after pulverization is adequate enough to ensure representative fusing and analysis.

The results for pulp duplicates from the 2015–2016 drilling programs are discussed below.

#### Gold

For both years, the laboratories produced generally similar gold results with relatively small scatter (low random error), as indicated by the abundance (majority) of points falling between the  $\pm 20\%$  thresholds. Linear regression slopes are close to 1.00 for the AA finish and the gravimetric finish. The correlation coefficients are greater than 97% for the AA finish and greater than 84% for the gravimetric finish. The results indicate an excellent reproducibility of gold values.



InnovExplo believes that gold results for the 2015 and 2016 pulp duplicates are reliable and valid.

Figure 11-2 shows a plot of gold pulp duplicates for samples assayed by ALS Chemex in 2015 and by Actlabs in 2016.

### Silver

For both years, laboratories produced generally similar silver results with relatively small scatter (low random error), as indicated by the abundance (majority) of points falling between the  $\pm 20\%$  thresholds. Linear regression slopes are close to 1.00 and the correlation coefficients are greater than 99%. The results indicate an excellent reproducibility of silver values.

InnovExplo believes that silver results for the 2015 and 2016 pulp duplicates are reliable and valid.

Figure 11-3 shows a plot of silver pulp duplicates for samples assayed by ALS Chemex in 2015 and by Actlabs in 2016.

### Copper

For both years, laboratories produced generally similar copper results with relatively small scatter (low random error), as indicated by the abundance (majority) of points falling between the  $\pm 20\%$  thresholds. Linear regression slopes are close to 1.00 and the correlation coefficients are greater than 99%. The results indicate an excellent reproducibility of copper values. The copper values assayed in percent have also been compared and returned similar tendencies.

InnovExplo believes that copper results for the 2015 and 2016 pulp duplicates are reliable and valid.

Figure 11-4 shows a plot of copper pulp duplicates (ppm) for samples assayed by ALS Chemex in 2015 and by Actlabs in 2016.

### Zinc

For both years, laboratories produced generally similar zinc results with relatively small scatter (low random error), as indicated by the abundance (majority) of points falling between the  $\pm 20\%$  thresholds. Linear regression slopes are close to 1.00 and the correlation coefficients are greater than 99%. The results indicate an excellent reproducibility of zinc values. The zinc values assayed in percent have also been compared and returned similar tendencies.

InnovExplo believes that zinc results for the 2015 and 2016 pulp duplicates are reliable and valid.

Figure 11-5 shows a plot of zinc pulp duplicates (ppm) for samples assayed by ALS Chemex in 2015 and by Actlabs in 2016.

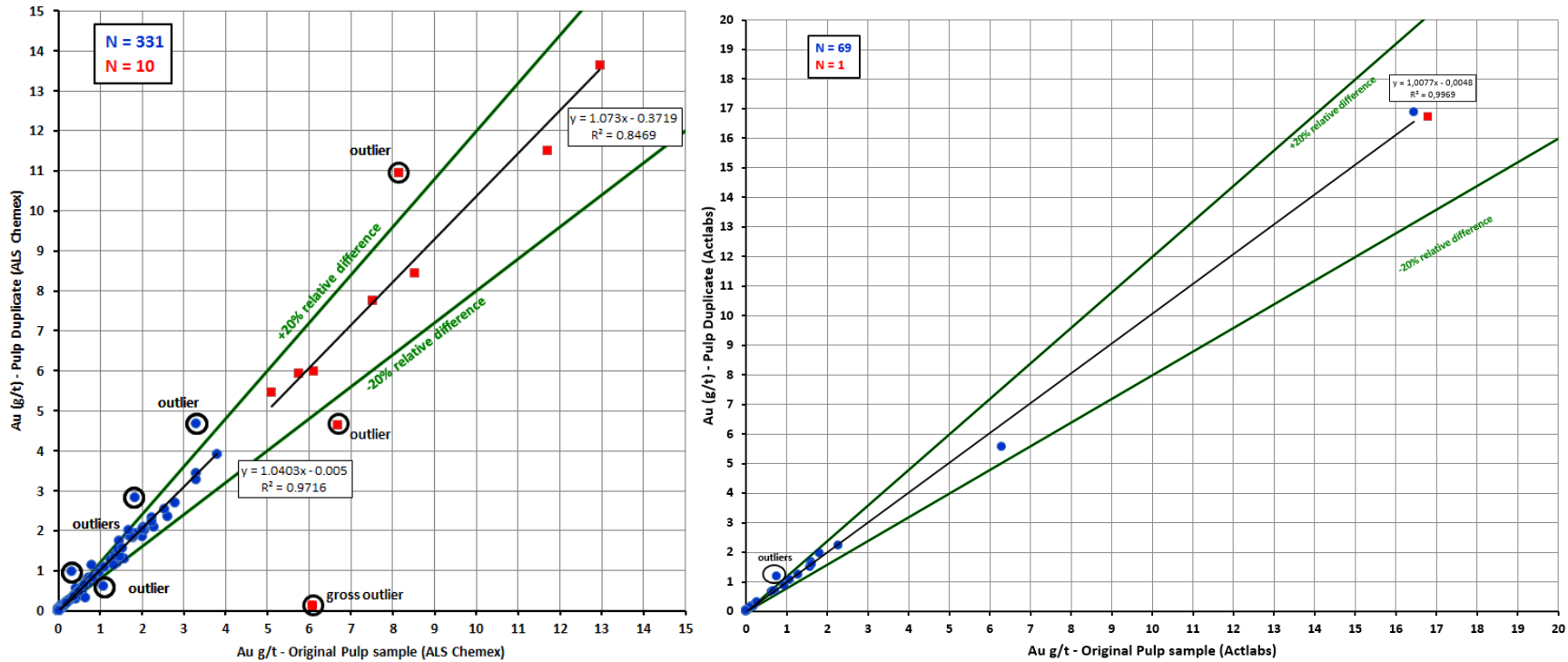

Figure 11-2: Plot of gold pulp duplicates from ALS Chemex in 2015 (left) and Actlabs in 2016 (right)  
 Blue circles denote AA finish and the red squares gravimetric finish. Green lines represent a field of relative difference of approximately  $\pm 20\%$ . The correlation coefficient (%) is the square root of  $R^2$  and represents the degree of scatter of data points around the linear regression slope.

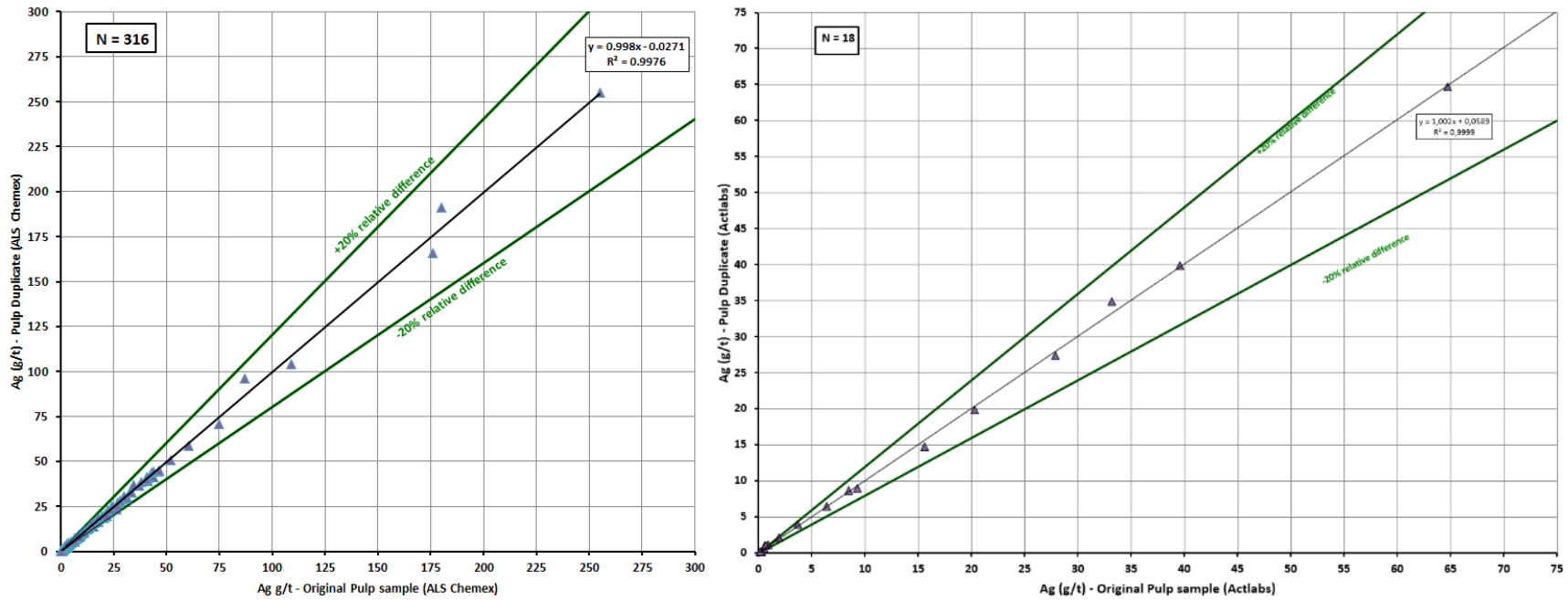

Figure 11-3: Plot of silver pulp duplicates from ALS Chemex in 2015 (left) and Actlabs in 2016 (right)  
 Green lines represent a field of relative difference of approximately  $\pm 20\%$ . The correlation coefficient (%) is the square root of  $R^2$  and represents the degree of scatter of data points around the linear regression slope.

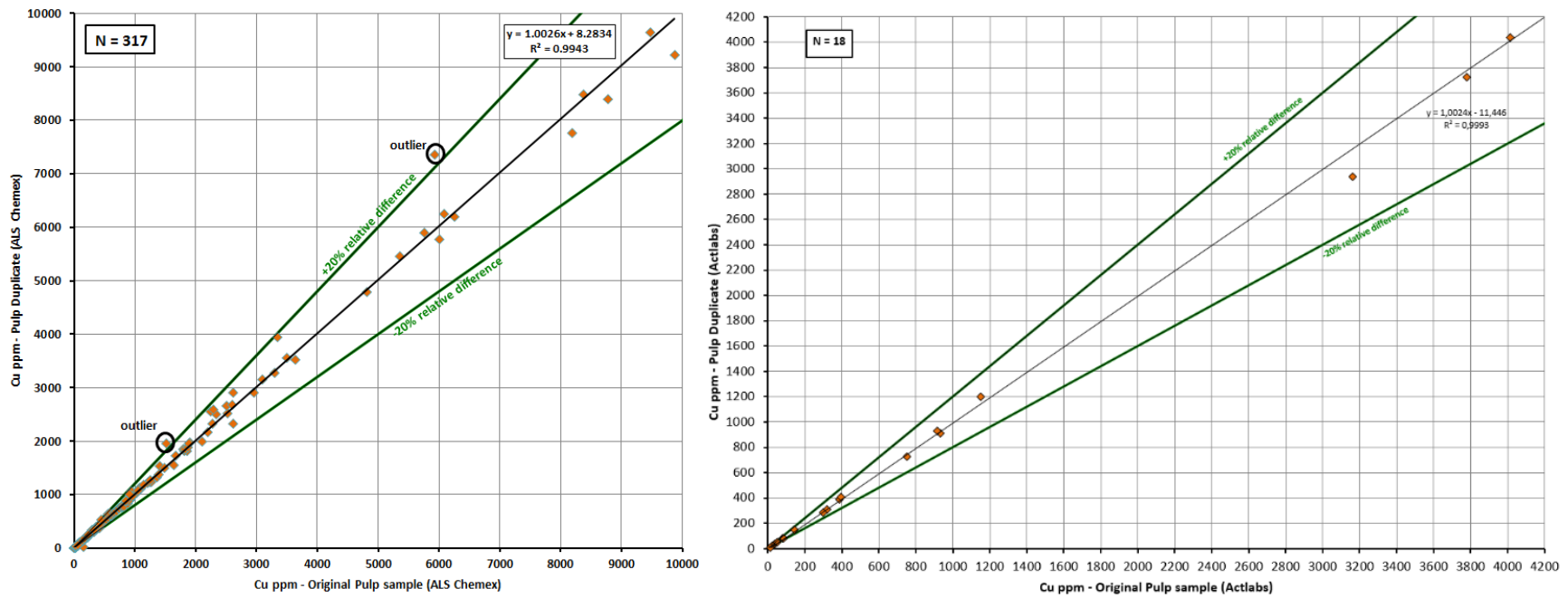

Figure 11-4: Plot of copper pulp duplicates (ppm) from ALS Chemex in 2015 (left) and Actlabs in 2016 (right)  
 Green lines represent a field of relative difference of approximately  $\pm 20\%$ . The correlation coefficient (%) is the square root of  $R^2$  and represents the degree of scatter of data points around the linear regression slope.

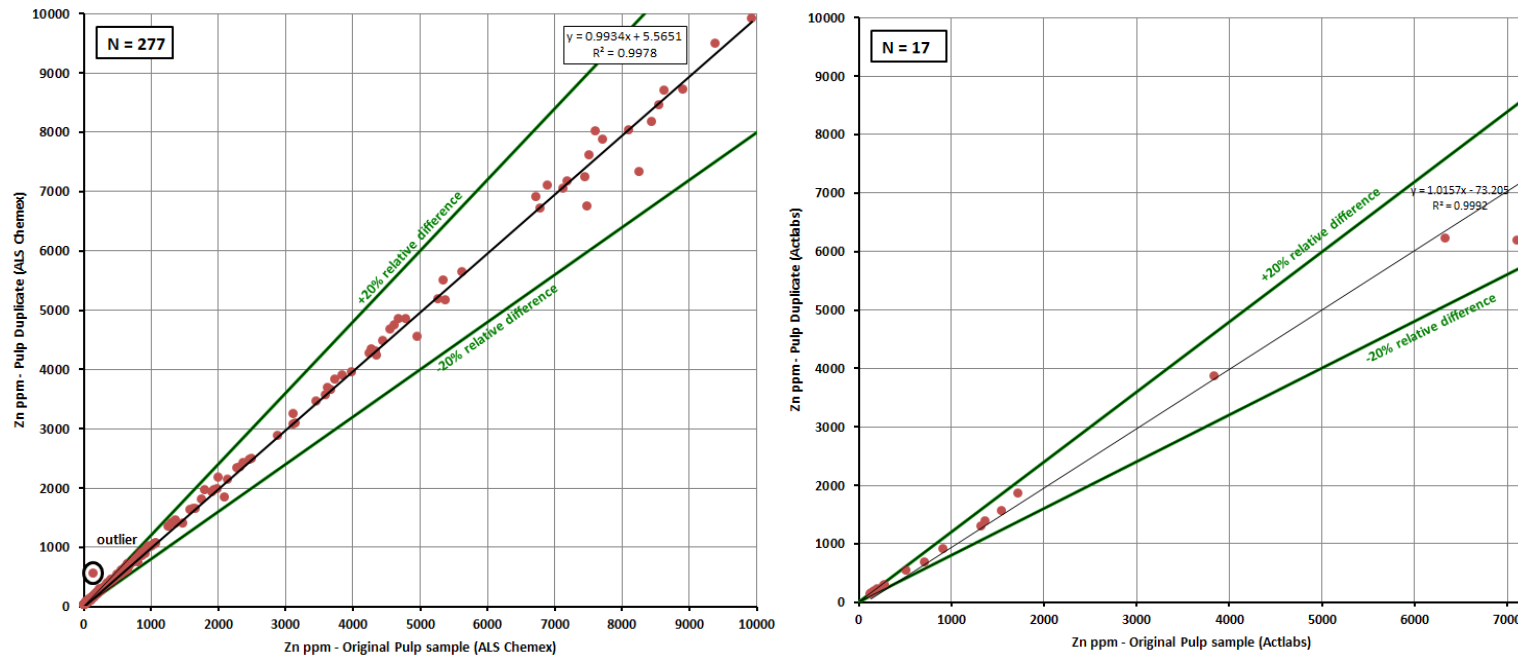

Figure 11-5: Plot of zinc pulp duplicates (ppm) from ALS Chemex in 2015 (left) and Actlabs in 2016 (right)  
 Green lines represent a field of relative difference of approximately  $\pm 20\%$

## Coarse Duplicates

Falco's quality control protocol requires that a coarse duplicate be prepared for every 27 samples in 2015 and every 20 samples in 2016. The duplicate is prepared by taking half the crushed material derived from the original sample. By measuring the precision of coarse duplicates, the incremental loss of precision can be determined for the coarse-crush stage of the process, thus indicating whether two sub-samples taken after primary crushing are adequate for the given crushed particle size to ensure a representative sub-split.

## Gold

For both years, laboratories produced generally similar gold results with relatively small scatter (low random error), as indicated by the abundance (majority) of points falling between the  $\pm 20\%$  thresholds. Linear regression slopes are close to 0.84 and the correlation coefficients are greater than 94%. The results indicate an excellent reproducibility of gold values.

InnovExplo believes that gold results for the 2015 and 2016 coarse duplicates are reliable and valid.

Figure 11-6 shows a plot of gold coarse duplicates for samples assayed by ALS Chemex in 2015 and by Actlabs in 2016.

## Silver

For both years, laboratories produced generally similar silver results with relatively small scatter (low random error), as indicated by the abundance (majority) of points falling between the  $\pm 20\%$  thresholds. Linear regression slopes are close to 1.0 and the correlation coefficients are greater than 99%. The results indicate an excellent reproducibility of silver values.

InnovExplo believes that silver results for the 2015 and 2016 coarse duplicates are reliable and valid.

Figure 11-7 shows a plot of silver coarse duplicates for samples assayed by ALS Chemex in 2015 and by Actlabs in 2016.

## Copper

For both years, laboratories produced generally similar copper results with relatively small scatter (low random error), as indicated by the abundance (majority) of points falling between the  $\pm 20\%$  thresholds. Linear regression slopes are close to 1.0 and the correlation coefficients are greater than 99%. The results indicate an excellent reproducibility of copper values.

InnovExplo believes that copper results for the 2015 and 2016 coarse duplicates are reliable and valid.

---

Figure 11-8 shows a plot of copper coarse duplicates for samples assayed by ALS Chemex in 2015 and by Actlabs in 2016.

### Zinc

For both years, laboratories produced generally similar zinc results with relatively small scatter (low random error), as indicated by the abundance (majority) of points falling between the  $\pm 20\%$  thresholds. Linear regression slopes are close to 1.0 and the correlation coefficients are greater than 98%. The results indicate an excellent reproducibility of silver values.

InnovExplo believes that zinc results for the 2015 and 2016 coarse duplicates are reliable and valid.

Figure 11-9 shows a plot of zinc coarse duplicates for samples assayed by ALS Chemex in 2015 and by Actlabs in 2016.



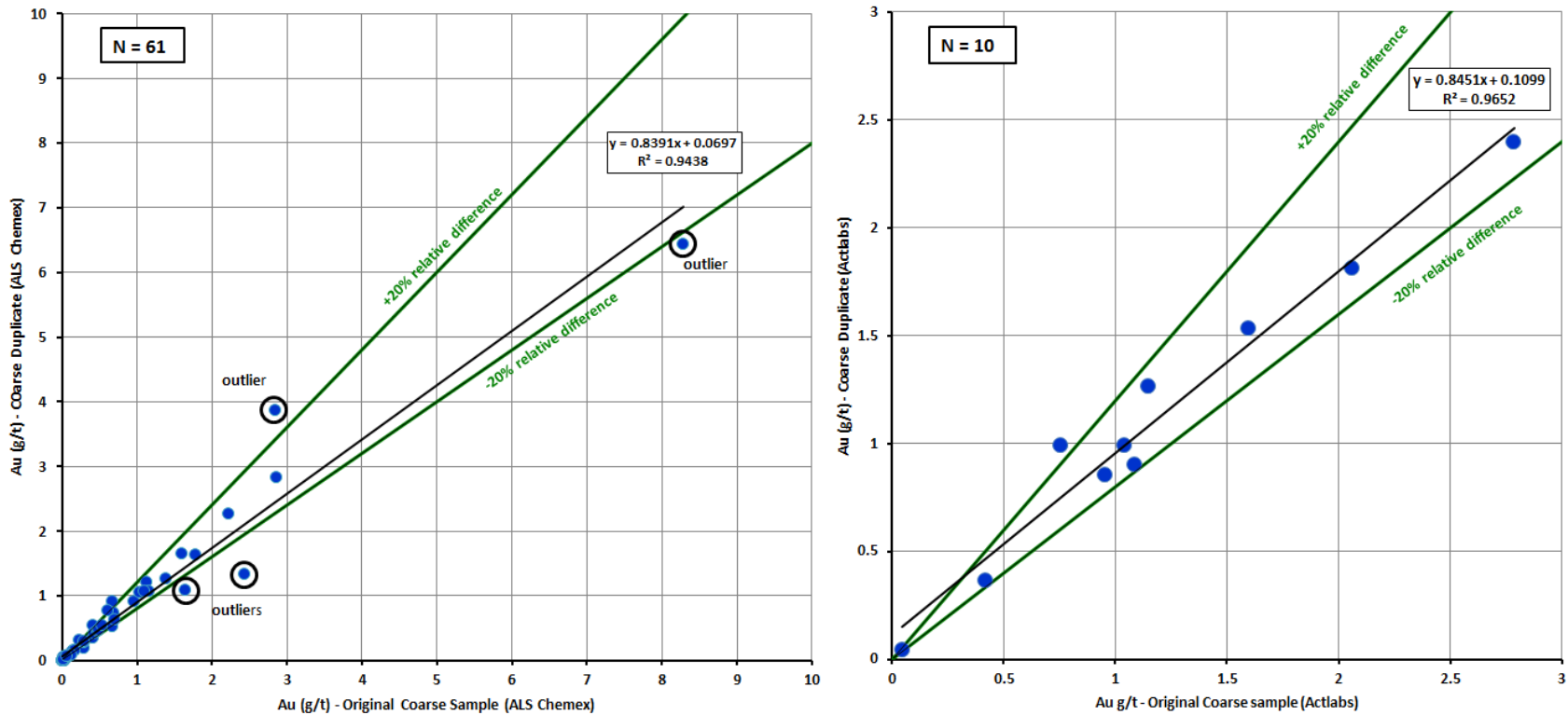

Figure 11-6: Plot of gold coarse duplicates from ALS Chemex in 2015 (left) and Actlabs in 2016 (right)  
 Blue circles denote AA finish and the red squares gravimetric finish. Green lines represent a field of relative difference of approximately  $\pm 20\%$ . The correlation coefficient (%) is the square root of  $R^2$  and represents the degree of scatter of data points around the linear regression slope.

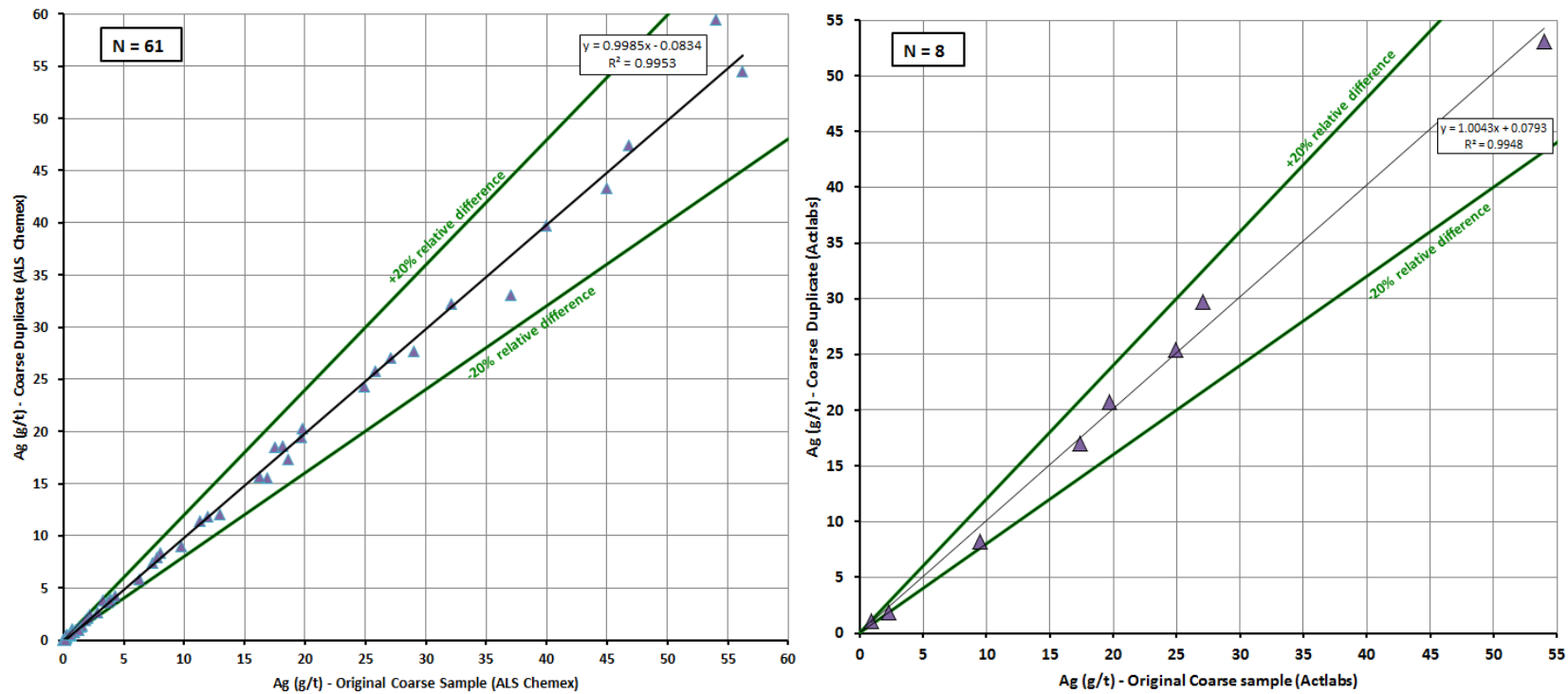

Figure 11-7: Plot of silver coarse duplicates from ALS Chemex in 2015 (left) and Actlabs in 2016 (right)  
 Blue circles denote AA finish and the red squares gravimetric finish. Green lines represent a field of relative difference of approximately  $\pm 20\%$ . The correlation coefficient (%) is the square root of  $R^2$  and represents the degree of scatter of data points around the linear regression slope.

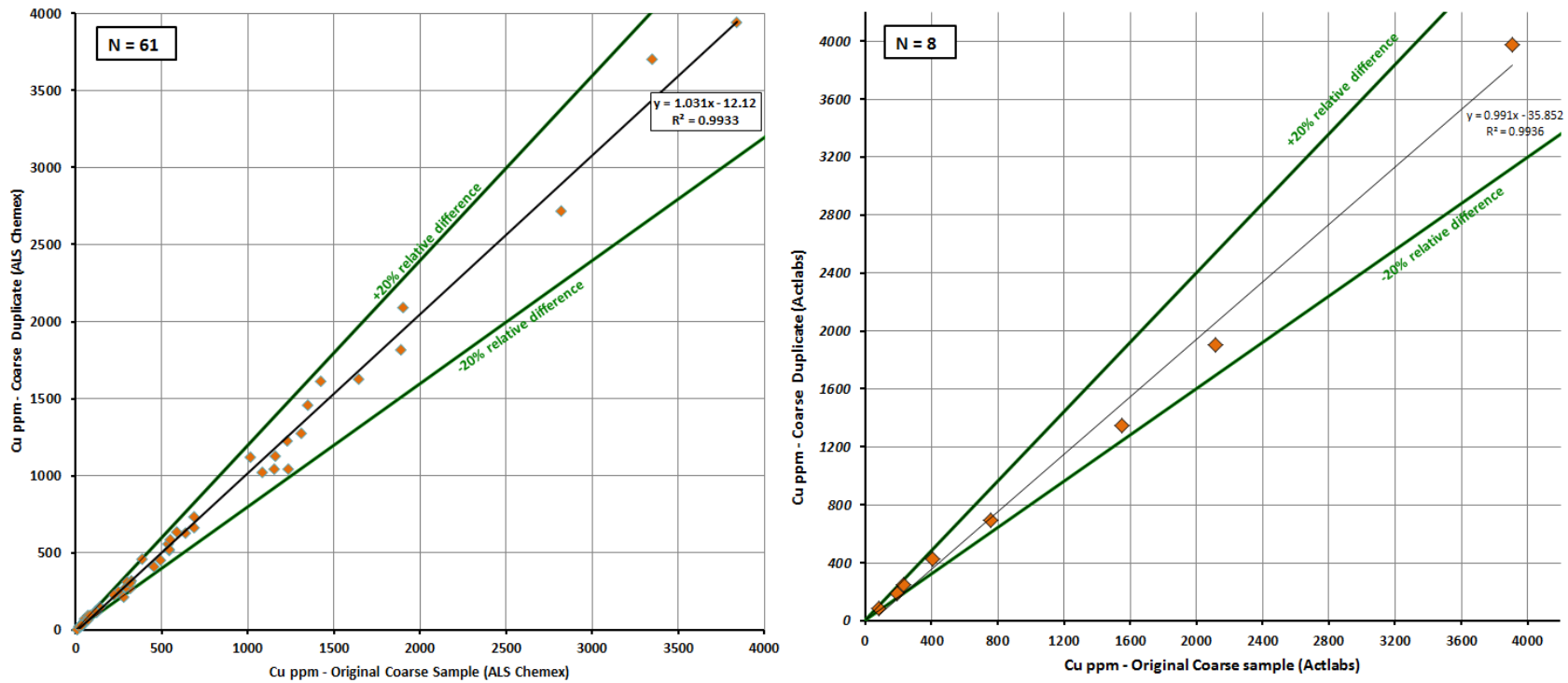

Figure 11-8: Plot of copper coarse duplicates from ALS Chemex in 2015 (left) and Actlabs in 2016 (right)  
 Blue circles denote AA finish and the red squares gravimetric finish. Green lines represent a field of relative difference of approximately  $\pm 20\%$ . The correlation coefficient (%) is the square root of  $R^2$  and represents the degree of scatter of data points around the linear regression slope.

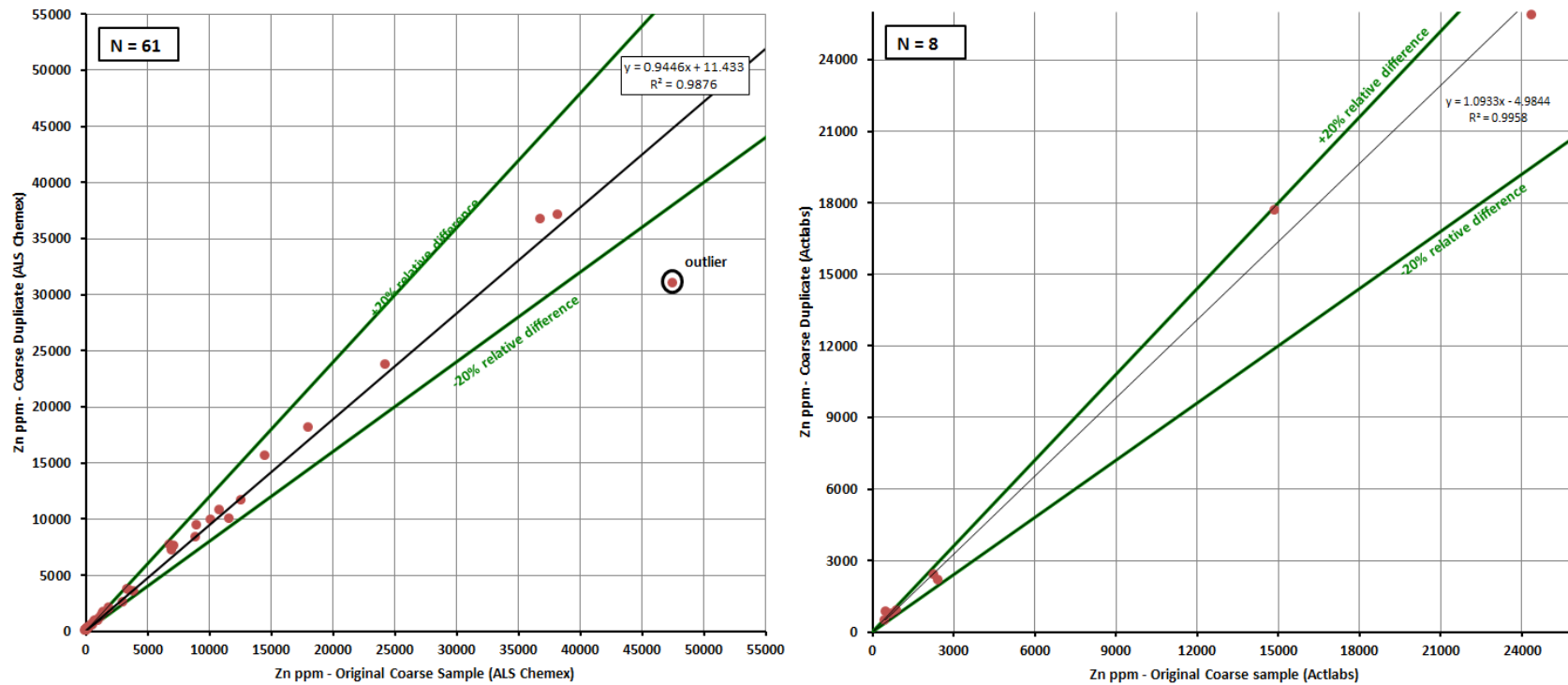

Figure 11-9: Plot of zinc coarse duplicates from ALS Chemex in 2015 (left) and Actlabs in 2016 (right)  
 Blue circles denote AA finish and the red squares gravimetric finish. Green lines represent a field of relative difference of approximately  $\pm 20\%$ . The correlation coefficient (%) is the square root of  $R^2$  and represents the degree of scatter of data points around the linear regression slope.

---

## 11.7 Conclusions

A statistical analysis of the QA/QC data provided by Falco did not identify any significant analytical issues. InnovExplo is of the opinion that the sample preparation, analysis, and QA/QC and security protocols for the Horne 5 deposit in 2015 and 2016 followed generally accepted industry standards, and that the data is valid and of sufficient quality to be used for mineral resource estimation.

## 12. DATA VERIFICATION

The October 2017 MRE presented in this Report is supported by the following data:

- A historical underground diamond drill hole database;
- A historical underground channel sample database;
- 2015–2016 confirmation and exploration diamond drilling programs.

Table 12-1 presents details of the data verification work conducted by InnovExplo from 2013 to 2016 to support the three resource estimates generated thus far.

The October 2017 MRE is largely supported by historical data. For this reason, a great deal of effort was made during the data verification process to obtain the highest degree of confidence as possible in terms of dataset quality and precision. The historical information used in this Report was taken from reports produced before the implementation of NI 43-101. No information about sample preparation, analytical or security procedures is available in the reviewed historical documents. InnovExplo assumes that the exploration activities conducted by earlier companies were in accordance with prevailing industry standards at the time.

Data verification was performed on two phases of historical underground DDH compilation conducted in 2013 and 2014 by Falco Pacific (now Falco Resources). The first historical compilation phase processed 4,384 underground holes, while the second processed 6,600 surface and underground holes (Table 12-1).

The use of 14,799 historical underground channel samples is also discussed in Table 12-1. These samples were recently compiled from historical plan views generated by Noranda (Table 12-1).

Results from a confirmation and exploration drilling program conducted by Falco in 2015 and 2016 were used in this October 2017 MRE. InnovExplo reviewed the following: laboratory accreditation and certification, sample preparation procedures, analytical methods, quality control (“QC”) protocols, assays, collar locations, and down hole surveys. In addition, the assays of 24 drill holes cutting mineralized zones were compared to the assays of nearby historical underground holes (see Chapter 10 – Drilling).

As part of the data verification process, InnovExplo also conducted two site visits in 2014 and 2015, and a third in 2016 that focused on the core logging facilities (see Section 12.10).

Table 12-1: Horne 5 Deposit MRE evolution (2014-2016) – Datasets and interpretation

Data set	Year	April 2014 MRE (February 17, 2014) <sup>(3)</sup>	March 2016 MRE (January 8, 2016) <sup>(3)</sup>	November 2016 MRE (September 26, 2016) <sup>(3)</sup>	October 2017 MRE (this Report) (July 25, 2017) <sup>(3)</sup>
Overall UG historical DDH		4,384	10,984	10,984	10,984
UG historical DDH used		4,384	4,384	5,938	5,938
Historical metallurgical test DDH data <sup>(1)</sup>		Not compiled	2,112	2,112	2,112
Historical UG sampling (channel samples)		Not compiled	Not compiled	14,799	14,799
2015/2016 confirmation surface drill holes		n/a	27	31	31
2015/2016 proximal exploration surface DDH		n/a	Not completed	8	11
Volume of historical developments and mined-out voids		6,197,597 m <sup>3</sup>	6,197,597 m <sup>3</sup>	6,341,746 m <sup>3</sup>	6,341,746 m <sup>3</sup>
<b>Interpreted Mineralized Zones</b>					
Volume of the main envelope (ENV_A)		38,511,116 m <sup>3</sup>	47,715,405 m <sup>3</sup>	50,102,486 m <sup>3</sup>	50,102,486 m <sup>3</sup>
Number of other envelopes (ENV_B to ENV_F)		3	3	5	5
Number of high-grade zones for Gold <sup>(2)</sup>		5	5	6	6
Number of high-grade zones for Silver <sup>(2)</sup>		-	2	3	3
Number of high-grade zones for Copper <sup>(2)</sup>		-	1	1	1
Number of high-grade zones for Zinc <sup>(2)</sup>		-	1	1	1
Number of high-grade zones for Density <sup>(2)</sup>		-	1	1	1
<b>Data Validation Process</b>					
Historical DDH verification		10% of 4,384 UG DDH (n=439)	5% of 6,600 additional Surface and UG DDH (n=330)	No UG DDH added	No UG DDH added
Historical assay verification		Assays for the validated 10%: n= 14,899	Assays for the validated 5%: n= 17,820	No UG DDH added	No UG DDH added
Historical DDH with remaining core		16 UG DDH resampled	No UG DDH with remaining material	No UG DDH with remaining material	No UG DDH with remaining material
Confirmation and exploration drill hole verification		n/a	QA/QC for 2015 confirmation drilling program	QA/QC for 2015/2016 confirmation and exploration drilling program	No additional validation
Verification of historical UG sampling (channel samples)		Not compiled	Not compiled	Global validation for every sampled drift	No additional validation
Impact on Resource Classification		MRE is entirely supported by historical DDH data. The 16 resampled historical DDH indicated a good reproducibility for gold, copper, zinc and silver, but they represent a small portion of the entire database. Only Inferred resources are defined.	Confirmation drilling program confirmed the accuracy of grades from historical drilling, and also confirmed the geometry, geological continuity and grade continuity of the deposit. The 19 DDH intercepting the Horne 5 deposit added 1,237 m of mineralized intervals to the database and confirmed the identified low- and high-grade gold zones. This program supported the classification of a large portion of resources as Indicated (81%).	Compilation of historical channel samples added 14,799 samples to the database. Sampling was done continuously in 23 of the 24 historical drifts in the Horne 5 deposit. Locally and globally, the samples confirmed the grades and locations of low- and high-grade gold zones. Channel samples were used to support the classification of 15-m blocks around sampled drifts as Measured resources (10%). The four DDH from the 2015/2016 confirmation and exploration program with mineralized intervals intersecting the Horne 5 deposit added 336 m to the database and confirmed again the geometry and geological/grade continuity both locally and globally.	The use of variable recoveries for each commodities enhanced local accuracy of grade estimation. The three DDH from the 2015/2016 confirmation and exploration program with mineralized intervals intersecting the Horne 5 deposit confirmed again the geometry and geological/grade continuity both locally and globally. The update of the commodities prices and exchange rates better reflect current market values.
<b>Resource categories</b>		<b>Inferred</b>	<b>Indicated and Inferred</b>	<b>Measured, Indicated and Inferred</b>	<b>Measured, Indicated and Inferred</b>

MRE = mineral resource estimate; UG = underground; DDH = diamond drill hole

<sup>(1)</sup> Note that 2,112 drill holes belong to the overall UG historical DDH database.

<sup>(2)</sup> Note that high-grade zones may overlap each other.

<sup>(3)</sup> Date in brackets is the effective date of the resource estimates.



## 12.1 Historical Underground Drill Hole Database

The October 2017 MRE is largely supported by historical data. A great deal of effort was made during the data verification process to obtain the highest degree of confidence possible in terms of dataset quality and precision. Data verification was performed on two phases of historical drill hole compilations carried out by Falco Pacific (now Falco) in 2013 and 2014.

## 12.2 First Compilation Phase

Falco compiled the first drill hole database using original logs from 1931 to 1976. The database contains collar locations, down hole surveys, assays and iron contents for 4,384 DDH, but does not include any lithological, alteration or structural information. InnovExplo's data verification, conducted from 2013 to 2014, included a review of collar locations, down hole surveys, assays and iron contents, and a validation of the formula to convert iron content to specific gravity ("SG"). Selected core intervals were examined during the site visit, and these were re-sampled at InnovExplo's core logging facilities in Val-d'Or.

More than 90% of the collar locations and down hole surveys were validated against georeferenced vertical sections and level plan views. Assays were validated against digital versions of the original paper logs because none of the certificates of analysis were available. A random selection of historical drill holes was compiled, including holes from each level (17 to 65 inclusive), to cover 10% of the database (n=439). The gold, copper, zinc and silver assays were validated for a total of 14,899 samples.

The iron assays (% Fe) for half the selected drill holes were also validated against a digital version of the original paper logs. This represents a total of 5% of the database or 2,036 iron assays.

InnovExplo verified the formula developed by Noranda to convert iron content to specific gravity. Noranda used this formula to estimate the tonnage and grade of the No. 5 Zone. In summary, the approach consisted of converting a sample's iron content into pyrite percentage using a tonnage factor of cubic feet per short ton (based on documented pyrite and rhyolite specific gravities) and then calculating a SG value ( $\text{g/cm}^3$ ). The InnovExplo validation was positive, as presented in Table 12-2, using a factor of 6.38 for massive pyrite and 12 for rhyolite (or remainder).

Table 12-2: Conversion of tonnage factor to specific gravity for pyrite and rhyolite

	Tonnage factor (ft <sup>3</sup> /ton)	Specific gravity (g/cm <sup>3</sup> )
Pyrite	6.38	5.02
Rhyolite	12.00	2.67

$$SG=1/(1.102 \times 0.30483 \times TF)$$

### 12.3 Resampling

To complete the data verification of the first compilation phase, InnovExplo re-sampled selected intervals of core from 16 DDH available at the Horne core storage site. The intervals were selected based on their metal contents. A total of 121 quarter-split samples (Figure 12-1) were sent to ALS Chemex in Val-d'Or, including a total of ten blanks and standards. Each sample was analyzed for gold, silver, copper, lead, zinc and iron.

The re-sampling results indicate a good reproducibility for gold, copper, zinc and silver (Figure 12-2 to Figure 12-4), and an excellent reproducibility of the calculated SG values. The re-sampling results were not used in any of the mineral resource estimates.



Figure 12-1: Photographs showing general presentation of quarter-split core after resampling

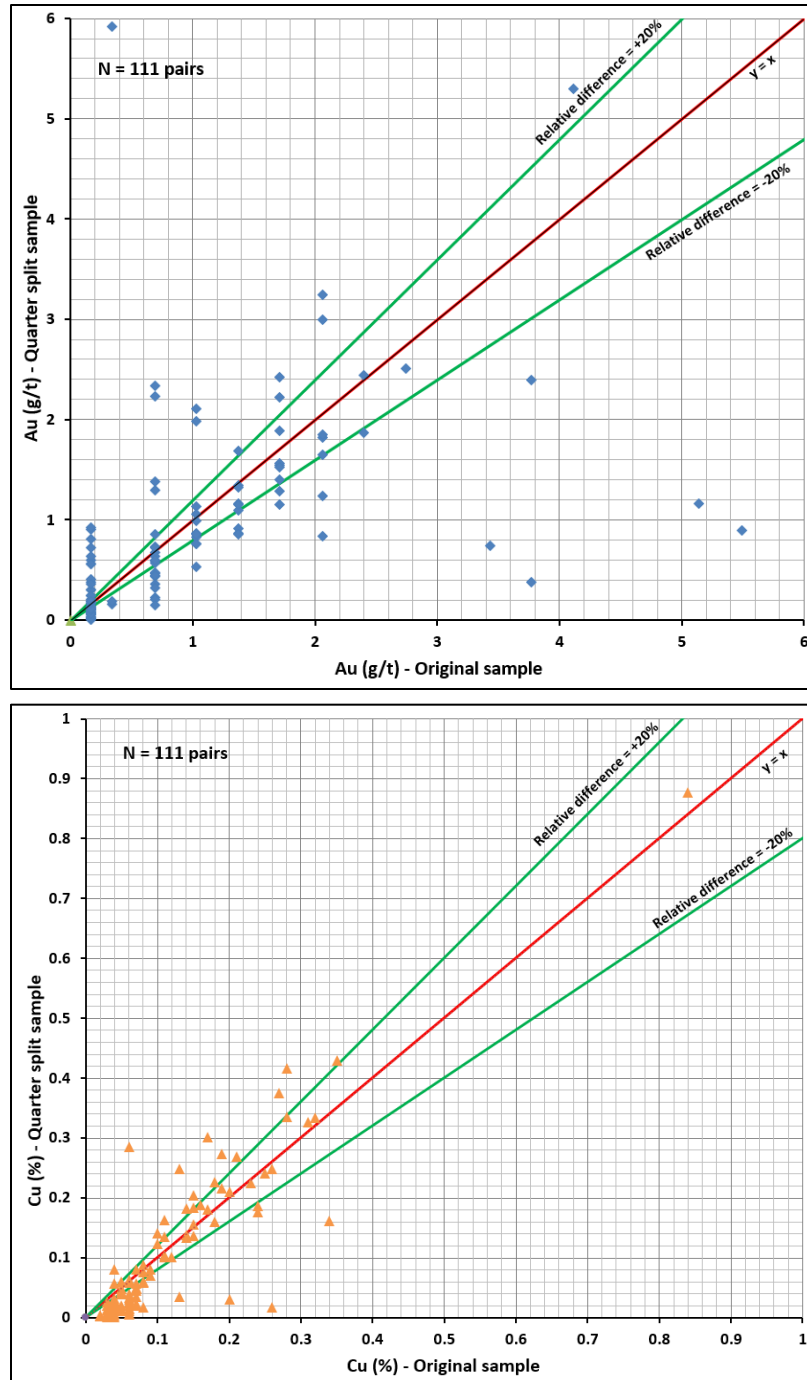

Figure 12-2: Linear graphs comparing original and quarter-split assays for gold (top) and copper (bottom)

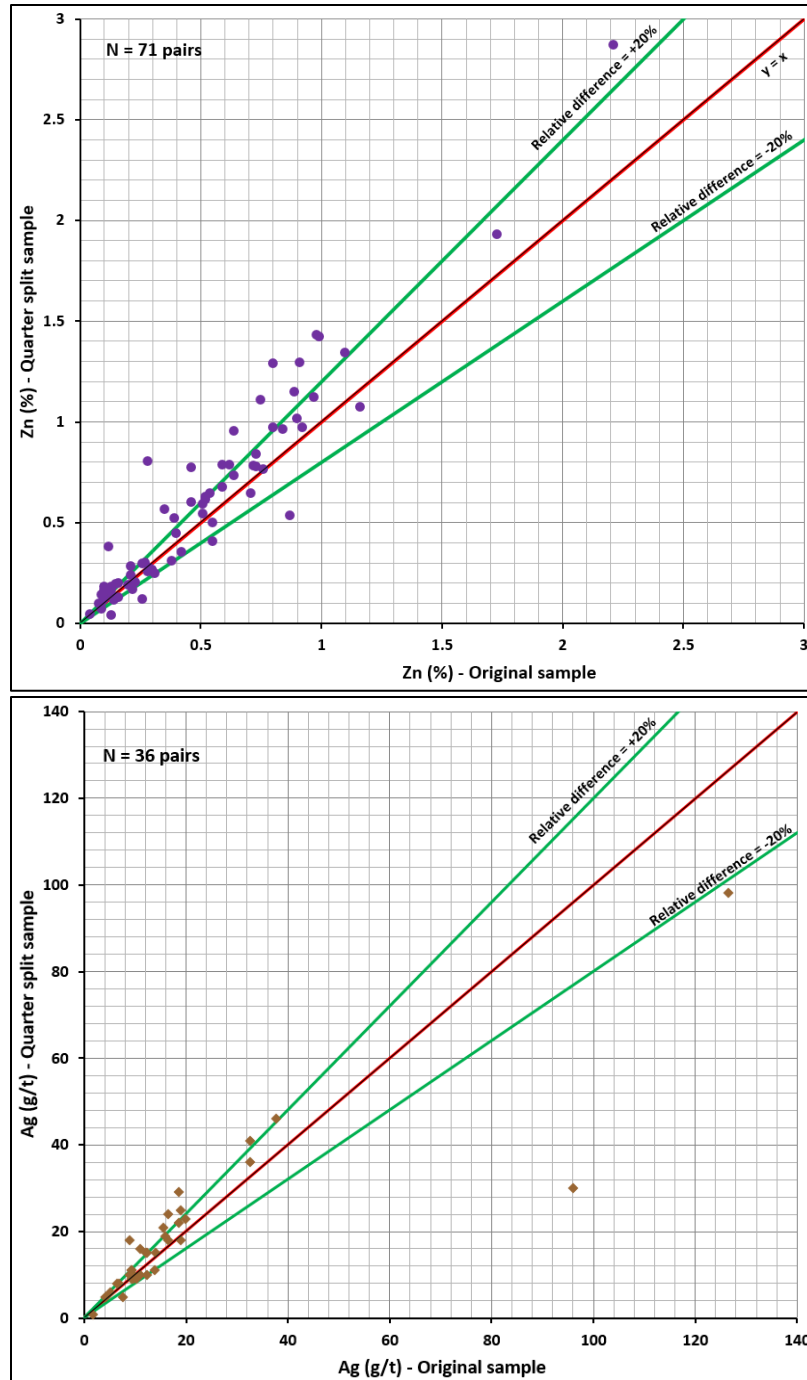

Figure 12-3: Linear graphs comparing original and quarter-split assays for zinc (top) and silver (bottom)

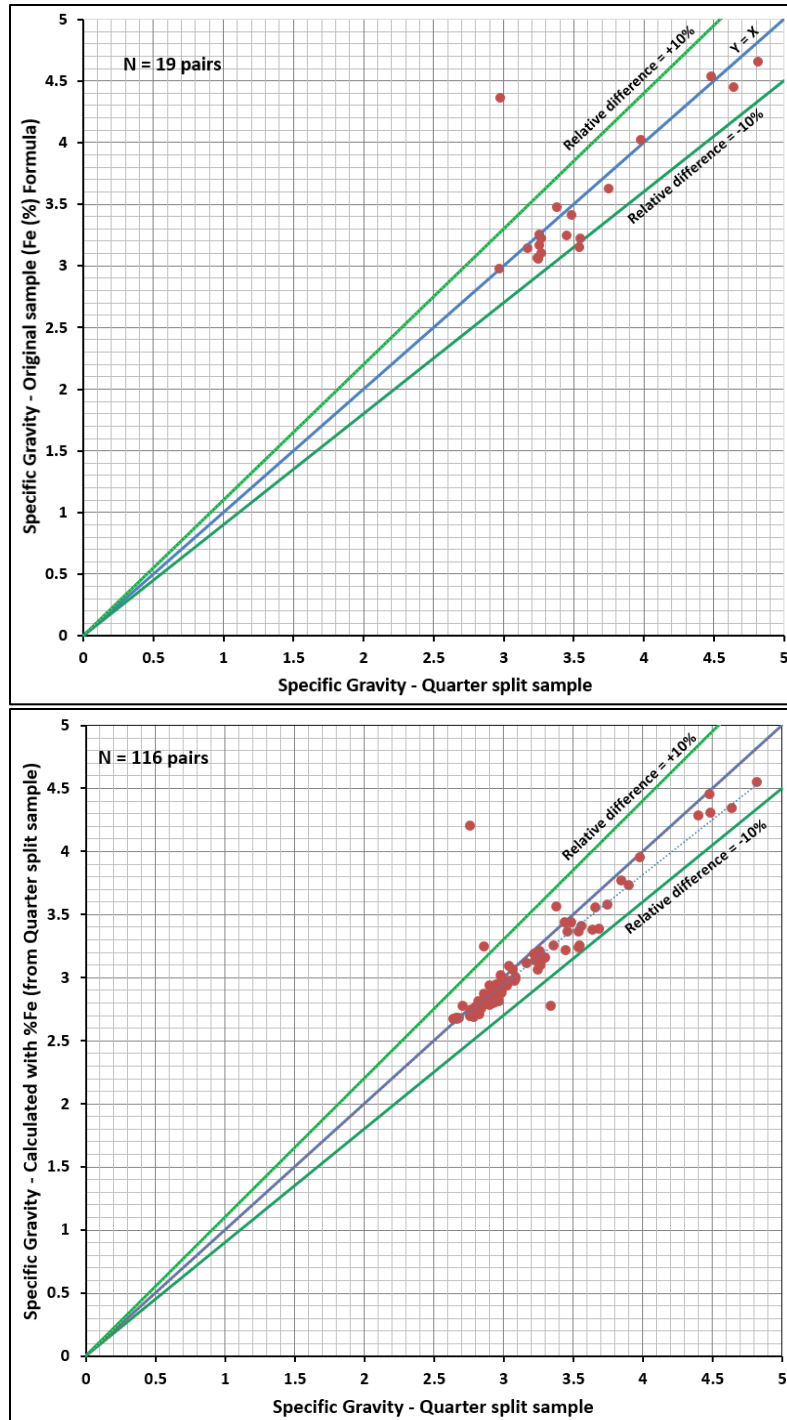

Figure 12-4: Graphs comparing Noranda’s calculated SG values for original core samples to InnovExplo’s calculated (top) and measured (bottom) SG values for quarter-split samples

## 12.4 Second Compilation Phase

Falco compiled the second drill hole database using original logs from 1931 to 1976. The database includes collar locations, down hole surveys, assays and iron contents for 6,600 DDH, but does not include any lithological, alteration or structural information. InnovExplo's data verification, conducted in 2014, included a review of collar locations, down hole surveys and assays. More than 90% of the collar locations and down hole surveys were validated using georeferenced vertical sections and level plan views.

Assays were verified against digital versions of the original paper logs provided by Falco because none of the certificates of analysis were available. A random selection of historical DDHs was compiled, including underground holes from each level (1 to 65 inclusive) in order to cover 5% of the database (n=330). The gold, copper, zinc and silver assays were validated for 17,820 samples.

As for the first compilation database, InnovExplo used the formula developed by Noranda to convert iron content to specific gravity.

## 12.5 Historical Underground Drill Hole Assays

### Trace or Nil Values and Detection Limits

On historical drill logs, gold values were reported as \$/t or oz/t, and trace amounts and zero are expressed as "T" or "Tr", and "Nil". For gold values in \$/t or oz/t, the lowest reported values are "0.3" and "0.003", respectively. For nil or trace values, InnovExplo assigned a value of 0.005 oz/t (0.17 g/t Au). This applied to 18% (or 16,443) of the historical values used to support the grade interpolation in this Report.

For silver, values were reported as oz/t. The detection limit was 0.01 oz/t. Trace values, expressed in logs as "Tr", were assigned a value of "0.0001". There were no nil values or any historical re-assays in the logs.

For copper and zinc, values were historically reported as percent (%). The detection limit was 0.01%. Trace values, expressed as "Tr" or "T", were assigned a value of "0". In cases of historical reassays, InnovExplo used an arithmetic average as the final value.

The author kept track of all original values and subsequent conversions using a field in the archived Geovia GEMS software ("GEMS") project.

Table 12-3 compiles the historical data, the conversion method and the proportion of each of the low-grade classes (for gold) relative to the overall gold grade population used to support this October 2017 MRE's interpolation.



Table 12-3: Statistical overview of historical low-grade gold classes and their respective conversion method

	Entries as reported in historical logs (\$/t or oz/t)	Reproduced value in database (\$/t or oz/t)	Conversion method (\$/t -> oz/t)	Final reported values (oz/t)	Conversion method (oz/t -> g/t) <sup>(1)</sup>	Final values used for October 2017 MRE (g/t)	Number of reported assays per values <sup>(2)</sup>	Total population	Percentage of total population per value	Comments
AUD (\$20)	Nil or Trace	0.00	n/a	0.01 or 0.005	1/2 (oz/t X 34.2857) or oz/t X 34.2857	0.17	8,177	35,814	22.8%	1/2 positive value for trace
	0.4	0.4	divided by 20	0.02	oz/t X 34.2857	0.69	8,518	35,814	23.8%	20 AUD corresponds to the consensus prices used
	0.8	0.8	divided by 20	0.04	oz/t X 34.2857	1.37	7,890	35,814	22.0%	20 AUD corresponds to the consensus prices used
	1.2	1.2	divided by 20	0.06	oz/t X 34.2857	2.06	4,768	35,814	13.3%	20 AUD corresponds to the consensus prices used
	1.6	1.6	divided by 20	0.08	oz/t X 34.2857	2.74	2,496	35,814	7.0%	20 AUD corresponds to the consensus prices used
	2.0	2.0	divided by 20	0.10	oz/t X 34.2857	3.43	1,342	35,814	3.7%	20 AUD corresponds to the consensus prices used
	> 2.0 to 96.8	> 2.0 to 96.8	divided by 20	0.12 to 4.84	oz/t X 34.2857	4.10 to 165.94	2,200	35,814	6.1%	20 AUD corresponds to the consensus prices used
Au_oz/t	Nil or Trace	< 0.000 or 0.00	n/a	0.01 or 0.005	1/2 (oz/t X 34.2857) or oz/t X 34.2857	0.17	8,266	53,306	15.5%	1/2 positive value for trace
	0.003 < > 0.008	0.003 to 0.008	n/a	0.01	oz/t X 34.2857	0.17 or 0.34	244	53,306	0.5%	Ounce values ranging from 0.003 to 0.008 rounded to 0.01 oz/t
	0.01	0.01	n/a	0.01	oz/t X 34.2857	0.34	7,799	53,306	14.6%	
	0.02	0.02	n/a	0.02	oz/t X 34.2857	0.69	9,624	53,306	18.1%	
	0.03	0.03	n/a	0.03	oz/t X 34.2857	1.03	7,323	53,306	13.7%	
	0.04	0.04	n/a	0.04	oz/t X 34.2857	1.37	6,162	53,306	11.6%	
	0.05	0.05	n/a	0.05	oz/t X 34.2857	1.71	3,914	53,306	7.3%	
	0.06	0.06	n/a	0.06	oz/t X 34.2857	2.06	2,771	53,306	5.2%	
	0.07	0.07	n/a	0.07	oz/t X 34.2857	2.4	1,909	53,306	3.6%	
	0.08	0.08	n/a	0.08	oz/t X 34.2857	2.73	1,239	53,306	2.3%	
	0.09	0.09	n/a	0.09	oz/t X 34.2857	3.09	838	53,306	1.6%	
> 0.09 to 22.21	0.09 to 22.21	n/a	0.09 to 22.21	oz/t X 34.2857	3.42 to 761.49	3,173	53,306	6.0%		

<sup>(1)</sup> No conversion method was mentioned for 12 assays. These historical values were expressed as oz/t.

<sup>(2)</sup> Summed percentages do not equal 100 due to the exclusion of intermediate values from this table (represents 1.2% of \$/t analyses and 0.1% of oz/t analyses)

---

### Change in the Historical Analytical Method (1948)

Noranda's internal report by P. Price (1956) discussed a change that occurred in the analytical method in 1948. The change was mainly due to the inadequacy of the analytical method for copper, as demonstrated by mill reconciliation figures. Additionally, for the same period, gold was reported in increments of two-hundredths of an ounce: Tr, 0.02, 0.04, 0.06, etc. No odd values (i.e., 0.01, 0.03, 0.05, etc.) were reported during that period.

Price concluded the pre-1948 analytical method had the following effects on each commodity:

- Overall underestimation of gold levels by 0.01 oz/st (0.3 g/t Au);
- Overall underestimation of copper levels by 0.1%;
- Overall underestimation of zinc levels by 0.3%.

In all, 2,286 holes used for this October 2017 MRE were drilled before 1948, and 3,545 were drilled after the change in the analytical method (Figure 12-5).

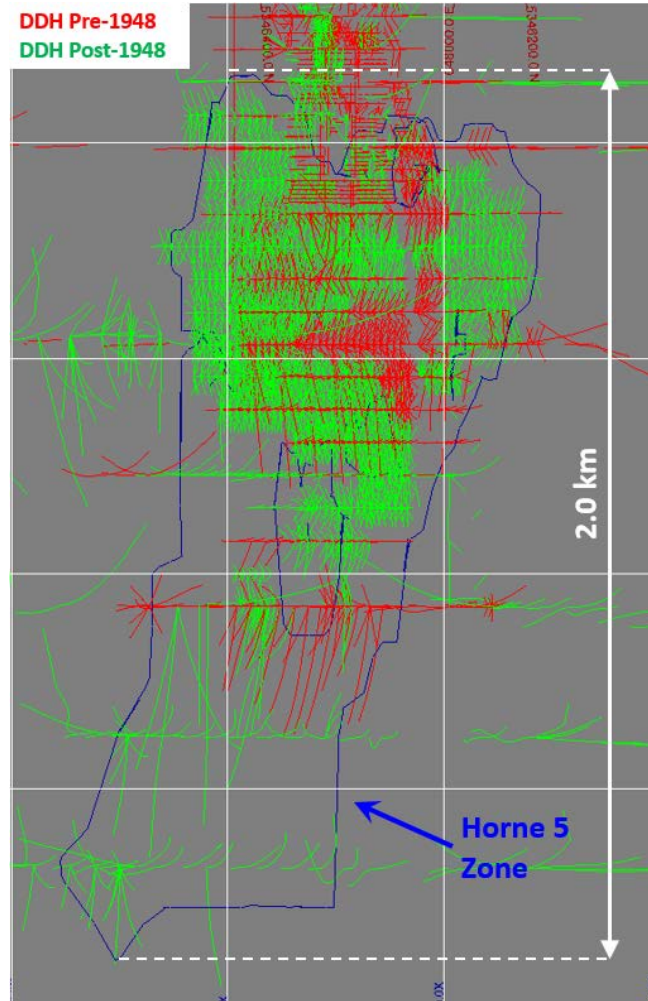

Figure 12-5: Composite longitudinal view looking north illustrating the proportion and distribution of historical underground drill holes with pre-1948 (red) and post-1948 assays (green)

InnovExplo compared the spatial pattern of pre- and post-1948 assays for gold, copper and zinc at incremental distances from the ore contact. As shown on Figure 12-6, only copper shows a significant difference, reflecting a negative bias for the pre-1948 analyses. The differences for gold and zinc are considered minor.

InnovExplo did not take into account Price's conclusion and instead used the raw pre-1948 gold, copper and zinc assays from the logs. For the purposes of this Report and regardless of the analytical period, InnovExplo assigned values of 0.34, 0.69, 1.03, 1.37 and 1.71 g/t Au for the values of 0.01, 0.02, 0.03, 0.04 and 0.05 oz/t Au, respectively (refer to Figure 12-7). A conversion factor of 34.2857 was used.

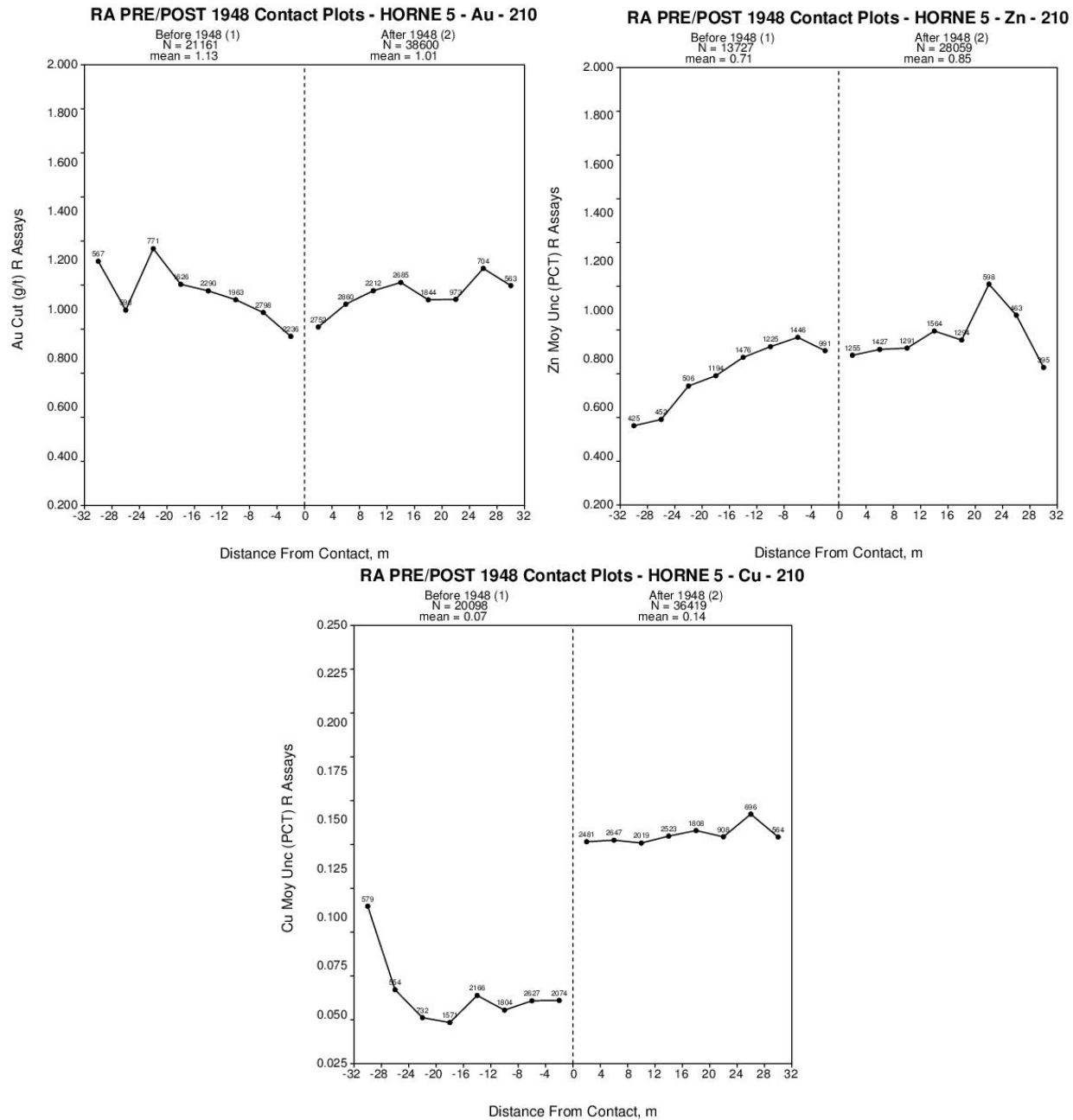

Figure 12-6: Contact plot for the main mineralized envelope of the Horne 5 deposit comparing pre- and post-1948 assays values for gold (top left), zinc (top right) and copper (bottom). Pre-1948 values are plotted on the left and post-1948 values on the right. Only copper shows a significant negative bias of about 0.1% Cu.

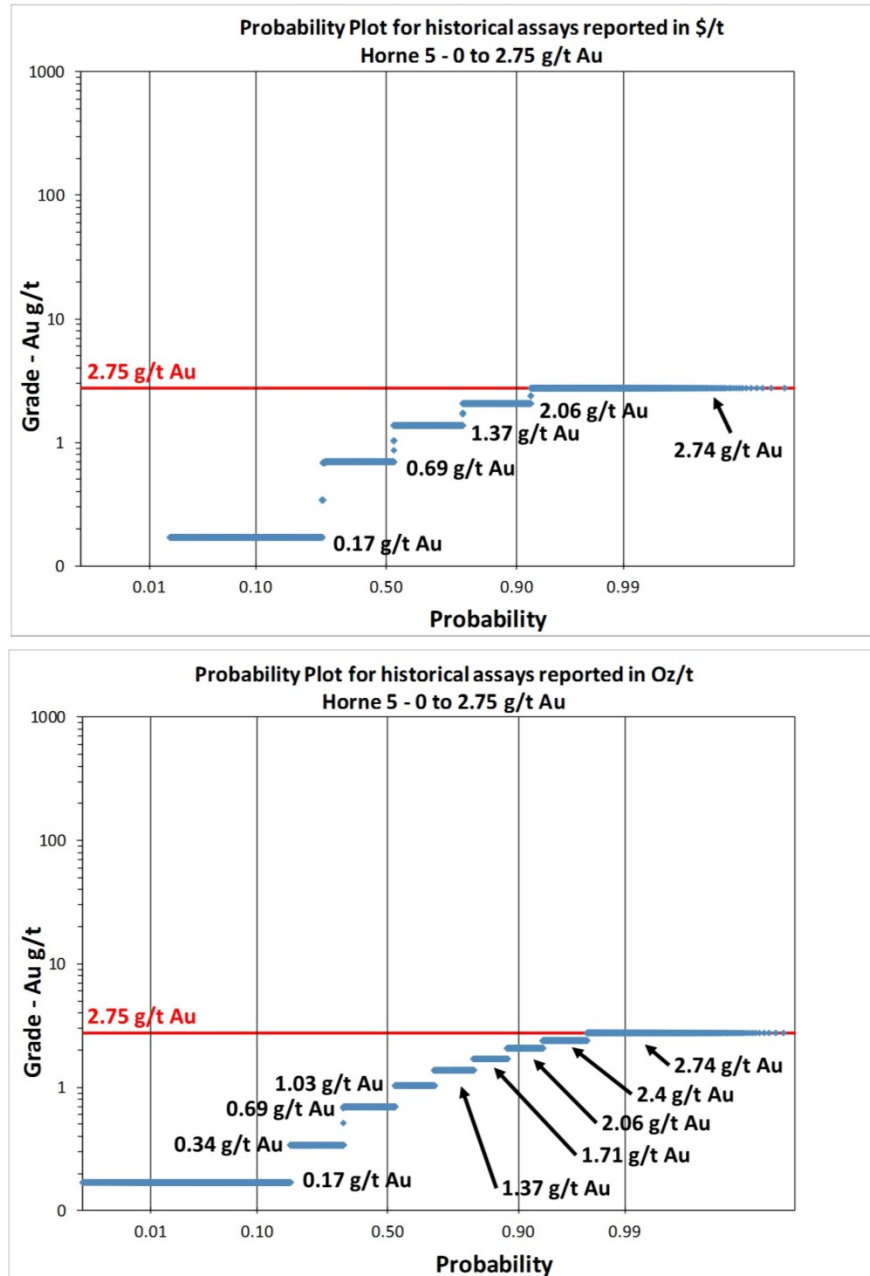

Figure 12-7: Probability plots of low-grade gold values in g/t reported historically as \$/t (top) and oz/t (bottom) Historical values expressed as \$/t have less classes because grades were expressed in increments of two-hundredths of an ounce

---

## 12.6 Comments on the Historical Underground Drill Hole Database

The first compilation phase processed 4,384 historical underground drill holes. These holes were used to delineate the Horne 5 deposit and its immediate surroundings. All the compiled DDH from the first compilation phase were used in the April 2014 MRE and March 2016 MRE (Figure 12-8, left). The second compilation phase processed 6,600 historical underground and surface drill holes. While the vast majority were drilled in the former Upper and Lower H mines, a significant number were from areas not previously mined, including areas adjacent to the Horne 5 deposit. Of that total, 1,554 were selected for the purpose of this Report (Figure 12-8, right), most of which belong to the former Lower H mine. The authors consider it necessary to include these holes in order to build an accurate interpretation capable of distinguishing the meeting point between the Lower H mine and the top of the Horne 5 deposit. The DDH from the second compilation phase that were used in this Report (n=1,554) represent 26% of the supporting drill hole database.

Minor errors of the type normally encountered in a project database were addressed and corrected for both compilation databases. The final drilling database is considered to be of very good overall quality. InnovExplo considers the database for the Horne 5 deposit to be valid and reliable.



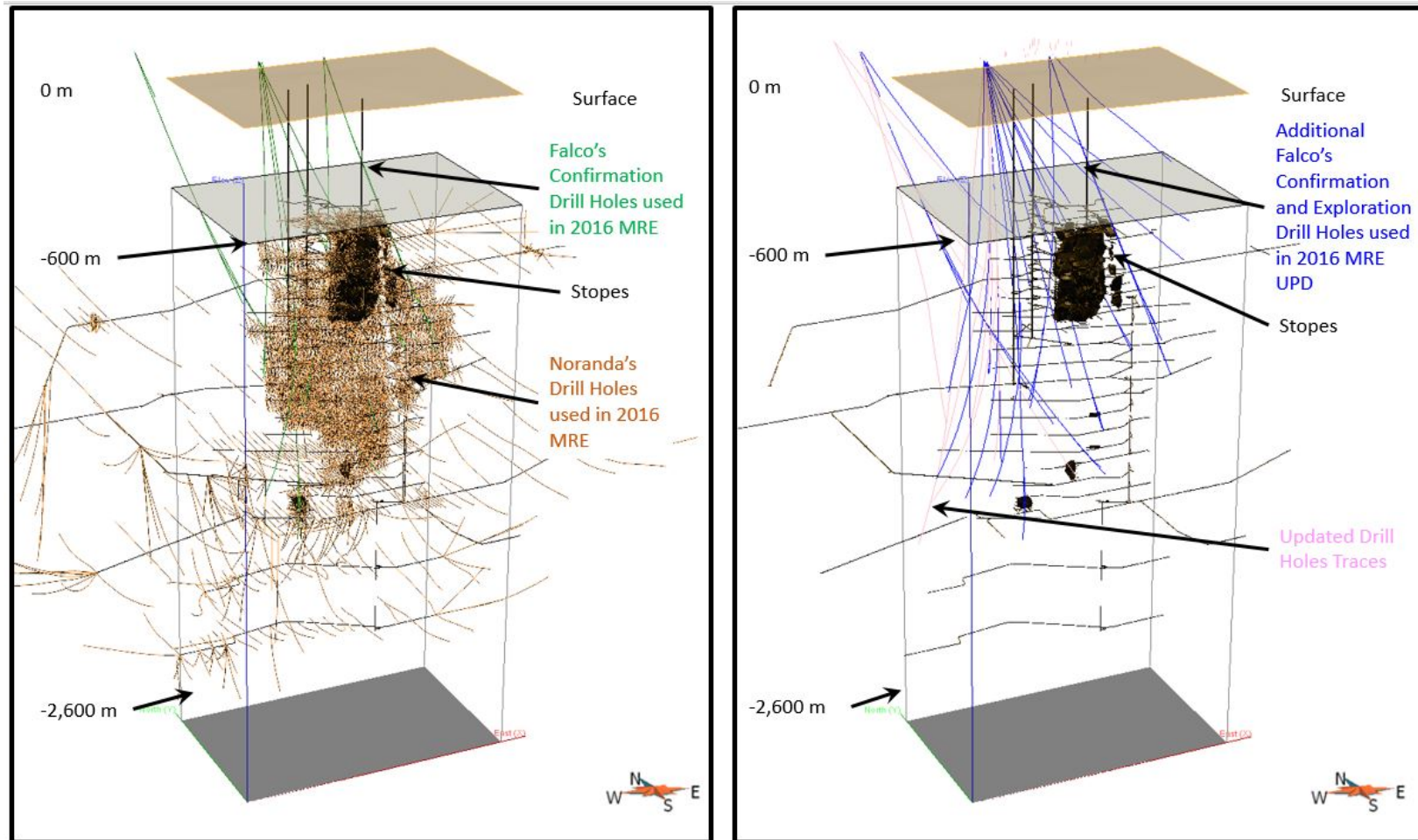

Figure 12-8: 3D view looking NE comparing the historical DDH (“Noranda’s drill holes”) used in the April 2014 and March 2016 MRE (left), and the holes added to the October 2017 MRE (right)  
The additional 1,554 historical underground DDH selected for this Report are shown in red on the right.



## 12.7 Historical Underground Channel Sample Database

Channel samples were compiled and digitized by InnovExplo using available historical plans. The plans are presented in Noranda's local mine grid system. Channel samples were documented for 23 of the 24 historical levels developed in the Horne 5 deposit. Channel samples were collected continuously along drifts, but were not analyzed for all commodities.

Channel sampling confirms the local geological and grade continuities observed in both historical and 2015–2016 drill holes (Figure 12-9). The channel samples correlate well with the location and geometry of mineralized envelopes and high-grade domains determined by historical underground drill holes (Figure 12-10). The channel sampling information was used to improve (refine) the interpretation of mineralized zones in the Horne 5 deposit.

Historical plans from Noranda's work constitute the only supporting information for the channel sample database. No other supporting historical documents have been found in Falco's vault, such as laboratory certificates, sample lists, etc.

InnovExplo compared historical drill hole composites and historical channel composites. The comparison shows a very good correlation between drill hole grades and the grades of corresponding channel samples. The composite values in the two datasets fall within a range of  $\pm 10\%$ , and correlate well within a 20-metre radius around the drift areas where the study was carried out. The comparison shows that channel composite values are slightly higher than drill hole composite values to a distance of 20 m from the drifts (Figure 12-11 and Figure 12-12).

In conclusion, channel sampling confirms the grades and grade continuity observed both locally and globally in historical drill holes. The authors are of the opinion that grades from channel samples can be used to guide the mineralized zone interpretation, but should not be used for grade interpolations to prevent the introduction of possible bias due to the slight positive overall grade difference (+10%) of channel samples compared to drill holes. InnovExplo recommends that channel samples be used for classifying Measured resources, but not for grade interpolation due to the lack of systematic values for zinc and silver and the possible positive bias.

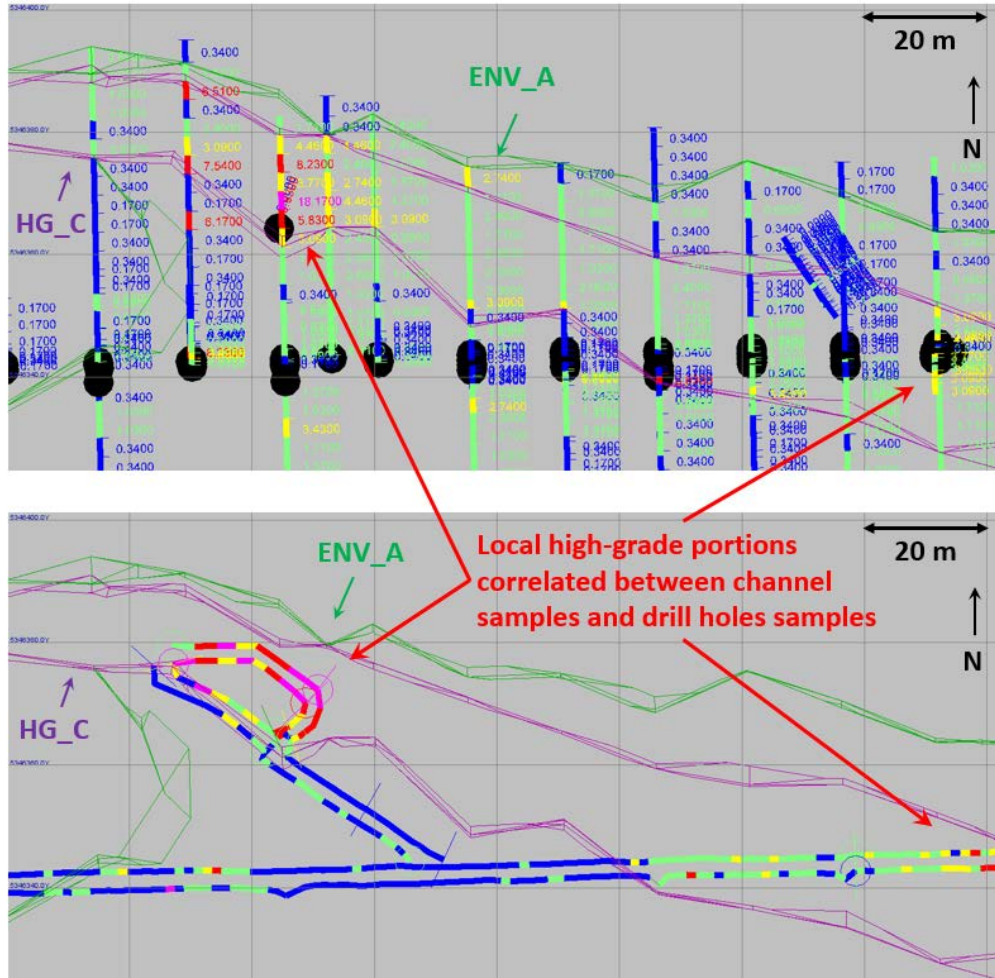

Figure 12-9: 3D plan view looking down on level 49 illustrating the gold grade correlation between channel samples and nearby DDH  
The high-grade gold domain HG\_C was originally delimited using only drilling information (top view)

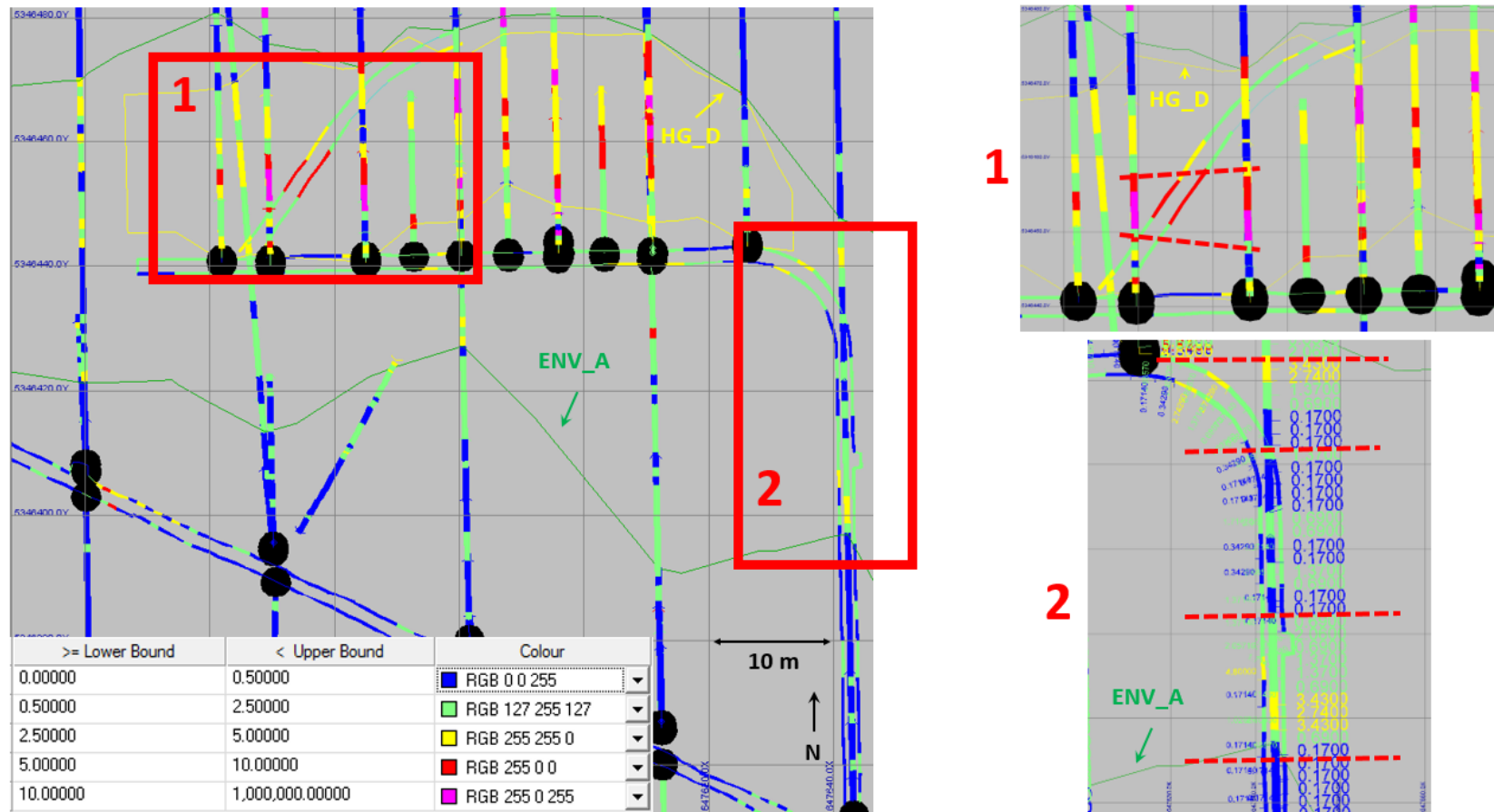
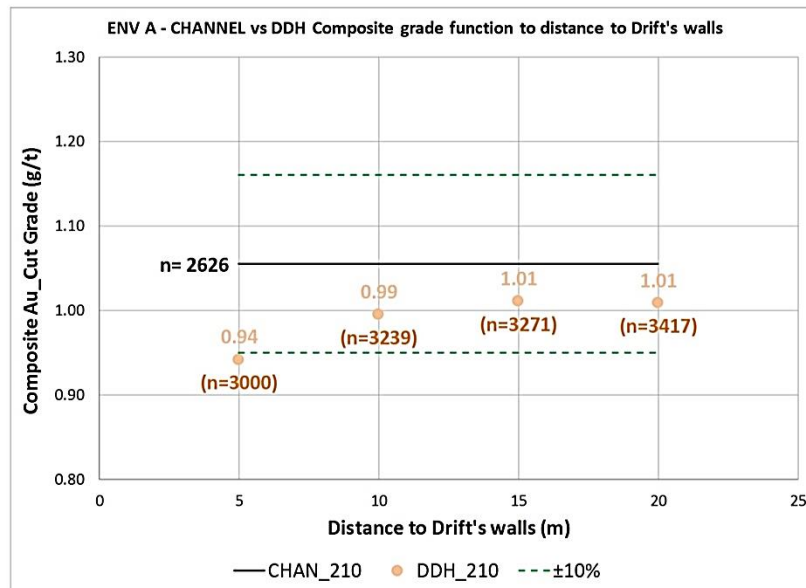
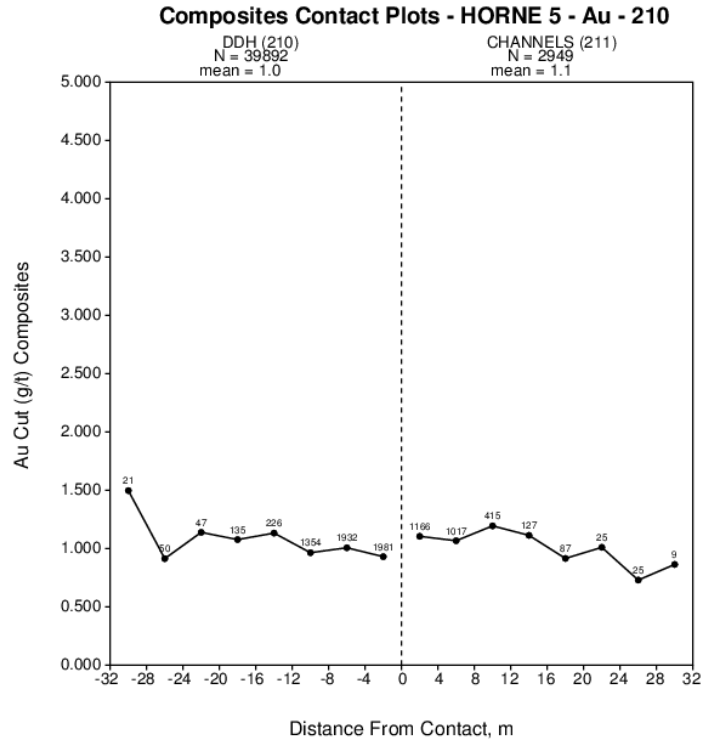

Figure 12-10: 3D plan view looking down on level 49 illustrating the Au grade correlation between channel samples and nearby DDH (left). The first close-up view (top right) illustrates the correlation of high-grade Au values in the HG\_D mineralized zone. The second close-up view (bottom right) illustrates the correlation of low-grade Au values in ENV\_A. Red dashed lines indicate local correlations.



**Figure 12-11: Comparison between channel sample composites and drill hole sample composites for ENV\_A (Rock code 210)**  
 The contact plot (top) shows that drill hole composite grades are slightly lower than channel composite grades. A similar trend is observed when the comparison is made using distance from the wall of a sampled drift (bottom).

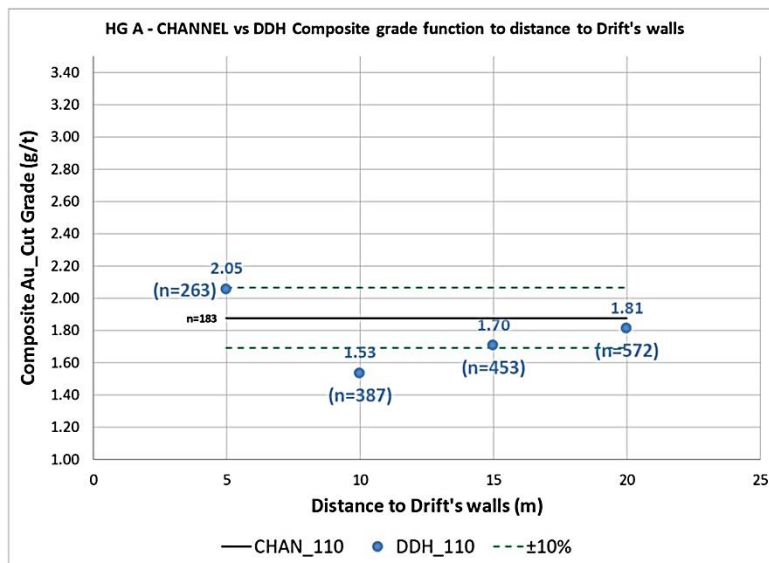
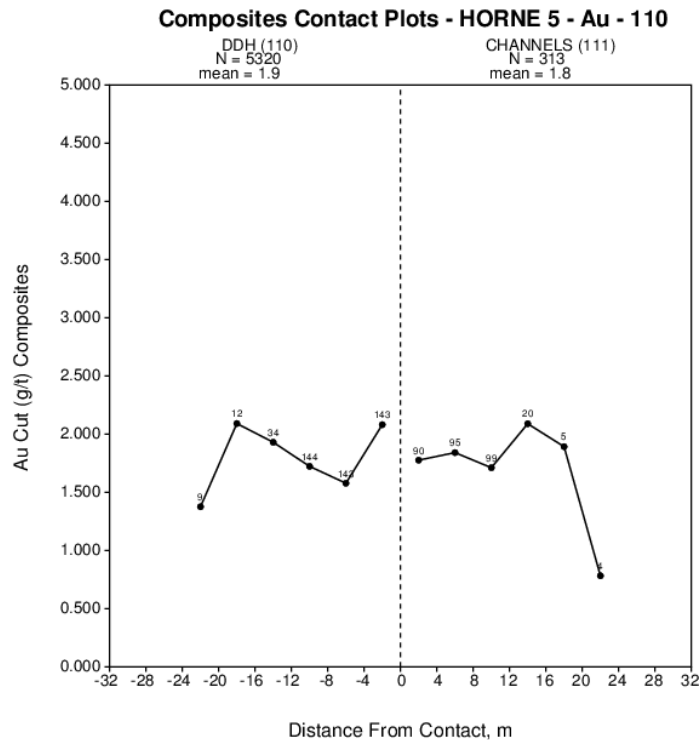

Figure 12-12: Comparison between channel sample composites and drill hole sample composites for HG\_A (Rock code 110)

Contact plot (top) shows that drill hole composite grades are slightly lower than channel composite grades except for very proximal composites. Similar trends are observed when the comparison is made using the distance from the wall of a sampled drift (bottom). Drill hole composites are only higher than channel results from the drift walls for the first 5 metres.

## 12.8 2015/2016 Confirmation and Exploration Drilling Program

Falco conducted a confirmation drilling program in 2015 and 2016 to convert some of the Inferred resources in the April 2014 MRE to the Indicated category.

The objectives were the following:

- Confirm the geometry of mineralized domains;
- Confirm the gold, copper and zinc grades, and also obtain silver grades which are lacking in historical drill assays;
- Obtain drill core material for metallurgical testwork.

The confirmation drill holes were planned to intercept the main mineralized envelope and at least one of the defined high-grade subzones (Figure 12-13).

Grade comparisons were performed for all assays over the length of the mineralized zone without applying a cut-off grade. Lengths represent core lengths. Given that historical drill holes are not parallel to the 2015–2016 drill holes, a cylinder with a 15-metre radius was defined around each hole to identify historical samples that could be used for the comparison.

The comparison exercise was run for all 2015–2016 holes in historically drilled areas (Figure 12-14). The 2015–2016 drilling program thus added 1,573 m of sampled intervals to the database (1,237 m in 2015 and 336 m in 2016) for a total of 1,924 samples.

Of the above total, mineralized intervals in these historically drilled areas represent 1,527 m of core or 1,875 samples. Using the 15-m cylinder approach, these 1,875 samples were compared to 2,822 historical samples.

The confirmation and exploration drilling program validated the geometry of mineralized zones previously defined by Noranda's historical work, and the grades compare favourably overall (Table 12-4). Nonetheless, local differences were observed between historical and confirmation drilling data. Wedges correlate well in terms of thickness, grade continuity and grade values when compared to pilot holes (Figure 12-15 and Figure 12-16).

InnovExplo is of the opinion that the above comparison adequately confirms the overall geometry, grade and grade continuity of the mineralized zones.



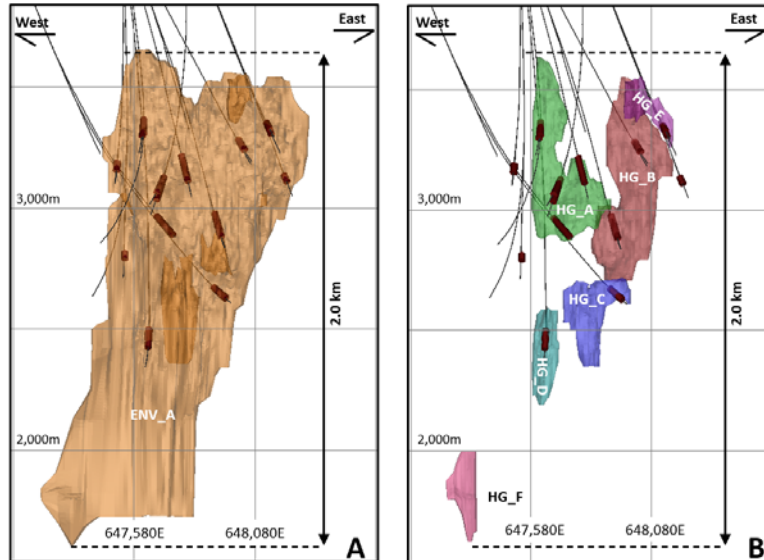

Figure 12-13: Cylinder with a 15-m radius around confirmation drill holes cutting Horne 5 mineralization  
 A) longitudinal view (looking north) of cylinders cutting the main mineralized envelope (“ENV\_A”);  
 B) longitudinal view (looking north) of cylinders cutting high-grade subzones.

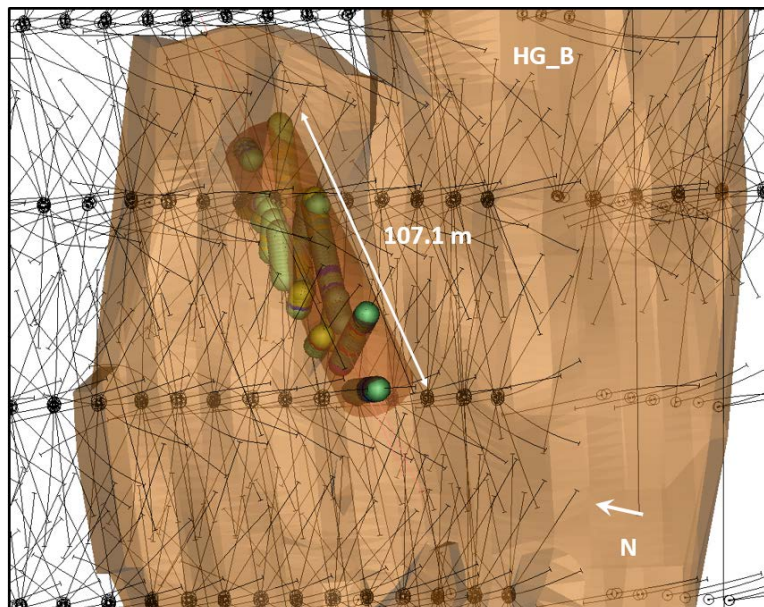

Figure 12-14: Illustration of a cylinder with a 15-m radius (transparent red shape) around confirmation drill hole (H5-15-08-W) cutting high-grade gold subzone HG\_B  
 The result is 215 historical samples (coloured dots) from underground drill holes (black traces) that can be used for comparison to the confirmation drill hole.



Table 12-4: Assay results from the 2015/2016 confirmation and exploration drilling program for drill holes intersecting Horne 5 mineralization

Hole_ID	2015/2016 confirmation drilling results (weighted average) for holes intersecting Horne 5 mineralization							Weighted average of historical raw assays within a 15-m radius cylinder around DDH				
	From (m)	To (m)	Length (m)	Au (g/t)	Ag (g/t)	Cu (%)	Zn (%)	Au_Eq <sup>(3)</sup> without Ag (g/t)	Au (g/t)	Cu (%)	Zn (%)	Au_Eq <sup>(3)</sup> without Ag (g/t)
H5-15-01	1110.0	1141.2	31.2	2.03	10.16	0.46	0.04	2.74	2.26	0.30	0.10	2.75
H5-15-01-Atw	1104.9	1141.6	36.7	0.88	4.51	0.27	0.06	1.32	2.18	0.35	0.12	2.76
H5-15-01-Btw	1098.0	1151.5	53.5	1.58 <sup>(1)</sup>	5.51	0.22	0.34	2.09	1.84	0.34	0.10	2.39
H5-15-02	1001.1	1102.0	100.9	1.32	29.46	0.11	1.94	2.50	1.14	0.11	1.19	1.92
H5-15-02-Atw	1002.0	1089.0	87.0	1.43	28.61	0.13	1.47	2.39	1.25	0.12	1.41	2.16
H5-15-03B	1248.3	1365.0	116.7	0.50	15.51	0.06	1.00	1.12	0.79	0.06	0.67	1.23
H5-15-03Dtw	1255.2	1389.6	134.4	0.55	15.44	0.08	1.10	1.24	0.82	0.06	0.70	1.28
H5-15-04	1302.0	1327.5	25.5	0.73	10.27	0.13	0.71	1.29	0.81	0.11	1.11	1.55
H5-15-04-Atw	1290.0	1320.3	30.3	0.95	11.05	0.14	1.79	2.10	0.83	0.12	1.13	1.61
H5-15-06	1189.0	1243.5	54.5	1.36	16.16	0.26	0.73	2.14	1.84	0.29	0.31	2.44
H5-15-06-Atw	1189.1	1246.7	57.5	1.72	22.50	0.32	0.99	2.71	1.89	0.28	0.28	2.45
H5-15-05	1803.0	1895.6	92.6	1.96	16.14	0.12	0.57	2.45	2.31	0.13	0.53	2.78
H5-15-05-Atw	1799.5	1852.5	53.0	2.49	15.17	0.14	0.70	3.06	2.16	0.11	0.40	2.54
H5-15-08	1441.0	1549.9	108.9	2.20	14.16	0.30	0.32	2.82	1.88	0.24	0.39	2.44
H5-15-08W	1443.0	1550.1	107.1	2.00	13.13	0.27	0.53	2.67	1.90	0.26	0.28	2.43
H5-15-07-A	1958.0	1986.0	28.0	0.41	17.32	0.10	1.86	1.53	0.91	0.38	0.13	1.53
H5-15-07-Btw	1956.0	1986.0	30.0	0.52	18.21	0.12	1.39	1.43	0.96	0.35	0.13	1.56
H5-15-07-C	1601.0	1751.3	150.3	1.51	12.11	0.08	0.40	1.84	0.96	0.09	0.51	1.36
H5-15-09-A	1177.5	1222.6	45.1	1.98	32.57	0.25	1.06	2.90	1.31	0.17	1.10	2.13

Hole_ID	2015/2016 confirmation drilling results (weighted average) for holes intersecting Horne 5 mineralization							Weighted average of historical raw assays within a 15-m radius cylinder around DDH				
	From (m)	To (m)	Length (m)	Au (g/t)	Ag (g/t)	Cu (%)	Zn (%)	Au_Eq <sup>(3)</sup> without Ag (g/t)	Au (g/t)	Cu (%)	Zn (%)	Au_Eq <sup>(3)</sup> without Ag (g/t)
H5-15-09-Btw	1177.0	1220.7	43.7	1.38	24.85	0.16	1.06	2.18	1.22	0.15	1.13	2.04
H5-16-17 <sup>(2)</sup>	1516.9	1550.5	33.6	2.16	46.41	0.40	0.87	3.21	n/a	n/a	n/a	n/a
H5-16-17-A <sup>(2)</sup>	1570.0	1582.4	12.4	3.02	52.18	0.29	1.77	4.38	n/a	n/a	n/a	n/a
H5-16-18	1163.0	1303.0	140.0	1.18	14.62	0.07	0.60	1.60	1.14	0.09	0.39	1.48
<b>Total 23 DDH (Average)</b>			<b>1572.95</b>	<b>1.42</b>	<b>17.68</b>	<b>0.17</b>	<b>0.85</b>	<b>2.14</b>	<b>1.36</b>	<b>0.16</b>	<b>0.57</b>	<b>1.92</b>
H5-15-01									-10.0%	55.2%	-62.5%	-0.6%
H5-15-01-Atw									-59.5%	-23.0%	-48.1%	-52.4%
H5-15-01-Btw									-14.1%	-33.9%	240.0%	-12.6%
H5-15-02									16.0%	1.5%	63.6%	30.2%
H5-15-02-Atw									14.8%	7.7%	4.2%	10.6%
H5-15-03B									-36.2%	1.1%	48.6%	-9.1%
H5-15-03Dtw									-33.3%	22.6%	56.5%	-3.3%
H5-15-04									-9.8%	14.3%	-36.2%	-17.2%
H5-15-04-Atw									14.3%	16.4%	58.5%	30.9%
H5-15-06									-25.9%	-9.9%	137.6%	-12.3%
H5-15-06-Atw									-8.9%	13.5%	258.6%	10.8%
H5-15-05									-14.9%	-6.0%	7.5%	-12.1%
H5-15-05-Atw									15.1%	24.4%	74.7%	20.6%
H5-15-08									17.2%	26.3%	-17.8%	15.6%
H5-15-08W									5.5%	3.1%	88.8%	10.1%
H5-15-07-A									-54.4%	-74.5%	1387.8%	-0.1%

Hole_ID	2015/2016 confirmation drilling results (weighted average) for holes intersecting Horne 5 mineralization							Weighted average of historical raw assays within a 15-m radius cylinder around DDH				
	From (m)	To (m)	Length (m)	Au (g/t)	Ag (g/t)	Cu (%)	Zn (%)	Au_Eq <sup>(3)</sup> without Ag (g/t)	Au (g/t)	Cu (%)	Zn (%)	Au_Eq <sup>(3)</sup> without Ag (g/t)
H5-15-07-Btw									-45.8%	-66.8%	942.2%	-8.7%
H5-15-07-C									57.9%	-9.3%	-20.4%	36.0%
H5-15-09-A									51.2%	48.9%	-3.5%	36.2%
H5-15-09-Btw									13.4%	5.9%	-6.2%	6.9%
H5-16-17 <sup>(2)</sup>									n/a	n/a	n/a	n/a
H5-16-17-A <sup>(2)</sup>									n/a	n/a	n/a	n/a
H5-16-18									3.5%	-22.2%	53.8%	8.1%
<b>Total 23 DDH</b>									<b>4.8%</b>	<b>4.5%</b>	<b>48.8%</b>	<b>11.4%</b>

<sup>(1)</sup> Capped at 25 g/t Au.

<sup>(2)</sup> Drill holes H5-16-17 and H5-16-17-A intercepted the Horne 5 Zone in an area classified as Inferred resources where no historical drill holes were intercepted by the 15-m-radius cylinder.

<sup>(3)</sup> 2015 parameters: Au\_Eq is based on parameters used for the March 2016 MRE on the Project: CAD/USD exchange rate = 1.27; Gold price= 1,165 USD/oz; Silver price= 15.77 USD/oz; Copper price = 2.53 USD/lb; Zinc price = 0.89 USD/lb.

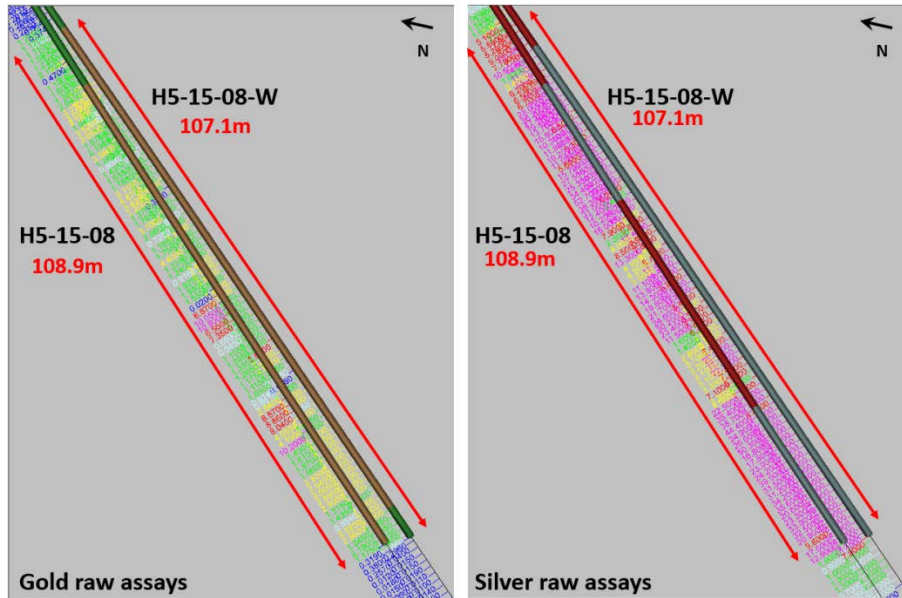

Figure 12-15: Illustration of good correlation between a pilot hole (H5-15-08) and its wedge (H5-15-08-W) for raw gold (left) and silver (right) assays  
Mineralized intervals are illustrated along drill hole traces by red lines.

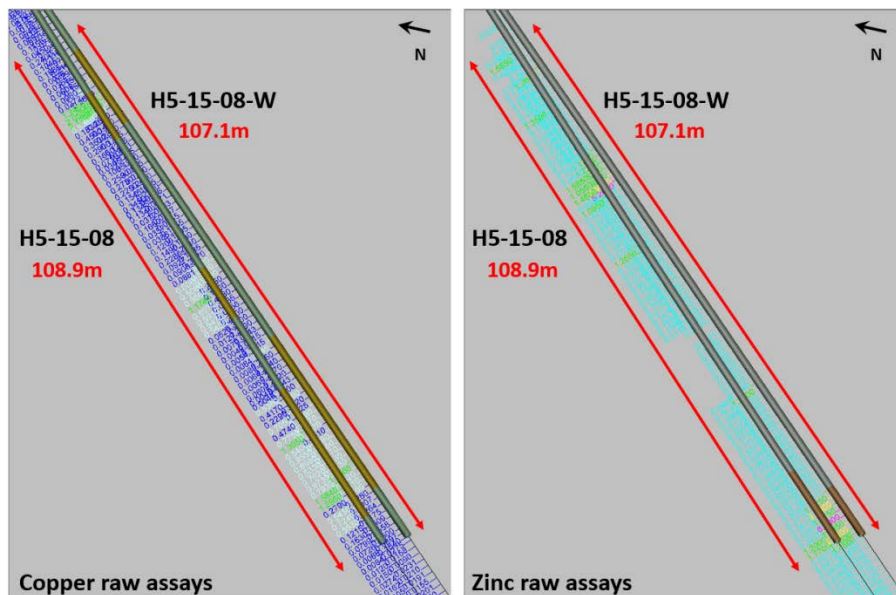

Figure 12-16: Illustration of good correlation between a pilot hole (H5-15-08) and its wedge (H5-15-08-W) for raw copper (left) and zinc (right) assays  
Mineralized intervals are illustrated along drill hole traces by red lines.

## 12.9 Relation between Silver Content and Specific Gravity

During the 2015–2016 confirmation drilling program, samples from a mineralized zone and its vicinity were assayed for silver and SG was measured. Figure 12-17 presents the average silver content per SG class (increments of 0.1 g/cm<sup>3</sup>) for the 2015 drilling campaign. It shows that samples with a SG of less than 3.0 g/cm<sup>3</sup> contain less than 5 g/t Ag, samples between 3.0 g/cm<sup>3</sup> and 3.5 g/cm<sup>3</sup> contain between 5 g/t and 10 g/t Ag, and samples greater than 3.5 g/cm<sup>3</sup> contain more than 20 g/t Ag. This clearly establishes a positive correlation between silver content and SG, which reflects sulphide content. The high-specific gravity domain, defined based on massive sulphide zones and SG values greater than 3.5 g/cm<sup>3</sup>, was also used in this October 2017 MRE to represent the high-silver domain.

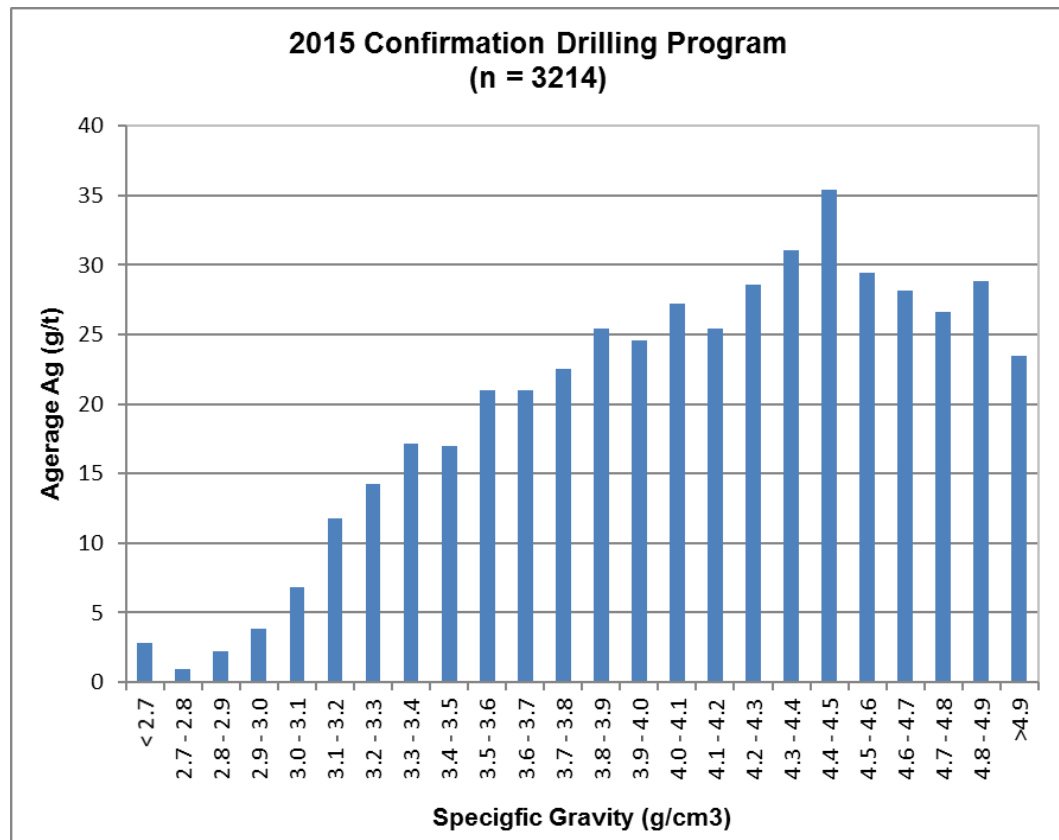

Figure 12-17: Average silver content per SG class

## 12.10 Site Visit

Data verification included two site visits in 2014 and 2015 by InnovExplo geologist Carl Pelletier, and a third site visit on June 9, 2016, by InnovExplo geologists Alain Carrier and Guilhem Servelle accompanied by Claude Bernier (Falco's Exploration Manager at Horne 5).

InnovExplo reviewed several sections of mineralized core from the 2015 confirmation drill holes at Falco's core logging facility (Figure 12-18). The aim was to systematically review wide intervals of core for geological features (lithologies, mineralized facies and textures). Grade continuity was also reviewed by comparing grades to visual geological features in intervals that had been used for the March 2016 MRE (refer to Jourdain et al., 2016).

As observed during the 2015 site visit, all core boxes were properly labelled and stored outside. Sample tags were still present in the boxes and it was possible to validate sample numbers and to confirm the presence of mineralization in half-core witness samples from mineralized zones (Figure 12-18).

InnovExplo is of the opinion that the protocols in place are adequate.



Figure 12-18: Half-core witness samples from mineralized zones



### 12.11 Remaining Half-Core Samples from 2015 Drilling Program

Apart from pulps and rejects, half-core samples from the nine pilot holes constitute the only remaining physical material from the 2015 confirmation drilling program. In wedge holes, whole core samples were sent for composite metallurgical tests and thus no core remains from these holes.

Several composite intervals were collected for metallurgical tests by taking the remaining half-core samples from the pilot holes

InnovExplo does not advise using the remaining half-core samples for composite metallurgical tests as it would destroy the only remaining core for future data validation audits. InnovExplo strongly recommends keeping witness half-core samples for all Horne 5 deposit intercepts in the future.

### 12.12 Conclusions

InnovExplo's data verification from 2013 to 2016 increased the confidence of the datasets supporting this October 2017 MRE, particularly in terms of geometry, geological continuity and grade continuity for the mineralized zones defined in the Horne 5 deposit. The historical drilling database is the principal supporting information for this October 2017 MRE. In addition, the 2015/2016 confirmation and exploration drilling program allowed Indicated resources to be classified in the March 2016 MRE, and the historical underground channel sample compilation allowed a portion of the Indicated resources to be converted into Measured resources since the November 2016 MRE and this October 2017 MRE.

InnovExplo believes that the local differences in grades between the historical and 2015/2016 drilling programs will be mitigated at the scale of the mine plan presented in the feasibility study.

InnovExplo considers the data to be valid and of sufficient quality to be used for the October 2017 MRE.



### 13. MINERAL PROCESSING AND METALLURGICAL TESTING

The metallurgical testwork related to the development of an optimized processing spreadsheet, mass balance inputs and metallurgical projections for the Horne 5 Project was carried out over two main periods. The first coincided with the preparation of the PEA and was initiated in 2015 and finished early in 2016. The second, commissioned for the FS preparation, started in July 2016. This second program was subdivided in three phases. Each one typically involved first a flotation testwork program followed by a cyanide leach program. Phase 1 and Phase 2 had been completed in late 2016 and early 2017. Phase 3 was still proceeding through the leaching testwork at the time of writing this Report.

The PEA testwork involved mostly differential flotation testwork and leaching trials with the pyrite concentrate and tailings. Limited grindability work was performed. A comparative signature curve for regrinding of the pyrite concentrate, with either an Isa mill or a HIG mill, was obtained. Limited cyanide destruction work with the INCO SO<sub>2</sub>/air process (INCO sulfur dioxide/air process) was also completed. This phase established the basis for the processing flowsheet and laid out expected reagent consumptions, major equipment sizing and metallurgical projections.

As mentioned above, the FS testwork program was divided in three main phases. Each included optimization work related to the differential flotation and leaching circuits. As well, Phase 1 included a comprehensive testwork program to establish the grindability characteristics of the deposit, and settling and filtration tests. These were complemented with pulp rheology, regrinding, cyanide destruction with both the INCO process and Caro's acid, and leach circuits' oxygen uptake testing. Phase 2 and Phase 3 were variability testwork programs, to test the robustness of the processing approaches with various ore types and over a wider range of feed grades as previously entertained.

With the results cumulated at the time of writing this Report (not incorporating the pending Phase 3 variability work), an optimized flowsheet was established, along with a sound basis for sizing the major processing equipment, establishing the operating costs associated with reagents and power demand and their variability with tonnage and ore type, and to project the expected metal recoveries and product quality.

#### 13.1 PEA Study Metallurgical Testwork

A metallurgical testwork program was developed by BBA, at the early stages of the PEA study, in order to characterize Horne 5 ore behaviour to mineral processing and extraction process. The objectives of the testwork were to develop a flowsheet allowing production of commercially acceptable concentrates of copper sulfide, zinc sulfide and optimize the leaching response of the pyrite flotation concentrate and tailings to produce gold/silver doré bars.

The initial part of the metallurgical work evaluated the mineralogy of core samples. A test plan was then developed to determine the ore's amenability to selective flotation separation of base metal sulfides and to evaluate the ore grindability. As a third part of the test plan, response to cyanide leaching of gold and silver was assessed in order to determine precious metal extraction yield and leach conditions. Finally, other tests were completed to provide conditions for cyanide destruction.

Completion of the PEA testwork was conducted by SGS Lakefield, based on BBA's test plan.

### 13.1.1 PEA Sample Selection and Compositing

Material used during metallurgical testwork was originated from portions of diamond drill cores obtained from the drilling campaign completed by Falco in 2015. Quartered cores of twinned drill hole wedges were sent to SGS Lakefield for compositing. Description of the sample selection is found in Sections 13.1.1 and 13.2.1 of this Report.

This exploration work included the drilling of nine pilot holes (H5-15-01 to H5-15-09) from surface. From these pilot holes, nine twinned wedges (H5-15-01Atw to H5-15-09Atw) intersecting the deposit at various depths were collected. Figure 13-1 illustrates the locations of the pierce points achieved with the wedged holes and their relative location within the PEA mineral resource envelope, as modelled by InnovExplo. On Figure 13-1, the stars represent the actual pierce points while the yellow dots are the intended targets.

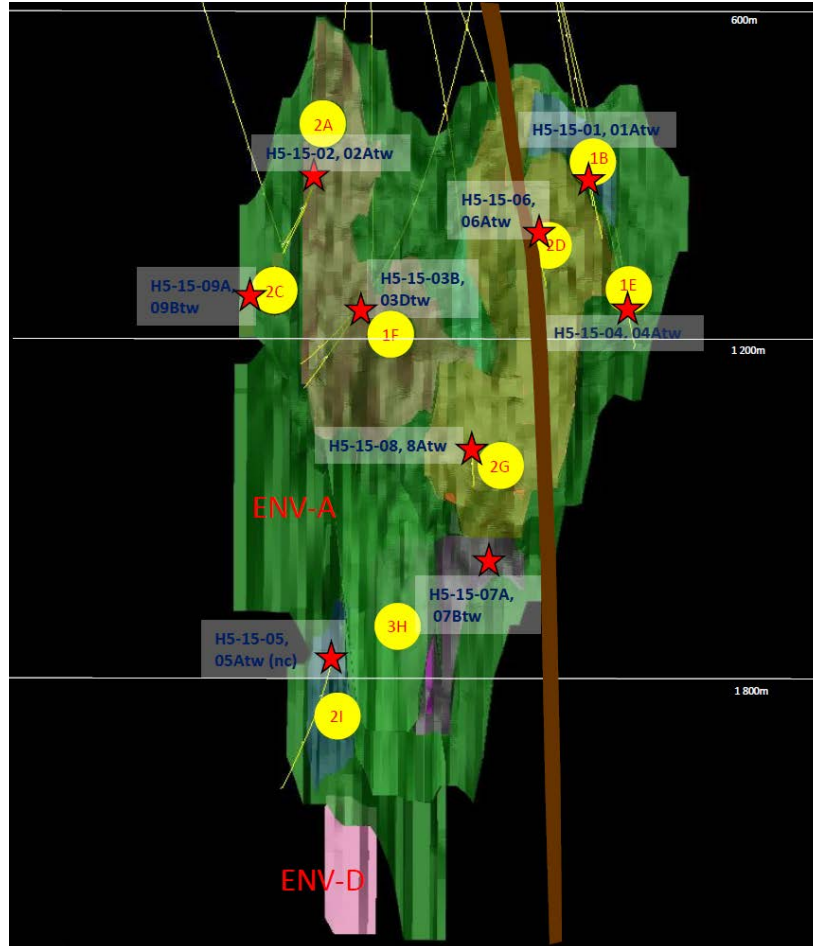

Figure 13-1: Section (looking north) of PEA drill hole pierce points within overall resource envelope  
(Source: InnovExplo, November 2016 MRE)

Quartered cores of the twinned wedges were made available for metallurgical testwork. All of the mineralized intercepts ended up being mobilized for this purpose in the various composites prepared.

The comminution tests were completed based on six composite samples (C1 to C6). BBA determined selection of drill hole intervals used to compose each of these composites as described in Table 13-1. Three of those composites were sent to Starkey & Associates (“Starkey”) and submitted to their proprietary SAGDesign test procedures. The other samples were submitted to SAG mill comminution (“SMC”) testing, bond rod mill work index (“RWi”), bond ball mill work Index (“BWi”) and abrasion index (“Ai”) determinations at SGS Lakefield.

Table 13-1: PEA comminution composites

Composite	Drill hole	Interval	
		From (m)	To (m)
C1	H5-15-01Atw	1,088.4	1,104.9
C2	H5-15-02Atw	1,080.5	1,088.0
C3	H5-15-02Atw	1,001.0	1,010.5
C4	H5-15-04Atw	1,290.0	1,305.0
C5	H5-15-04Atw	1,160.0	1,203.0
C6	H5-15-06Atw	1,207.8	1,217.0

As seen in Figure 13-1, the four twinned holes involved in these comminution samples are all found in the upper portion of the main resource envelope (“ENV\_A”).

Composite samples for the mineral beneficiation testing were selected also by BBA from seven of the drill holes completed by Falco in 2015. The intervals for each composite are presented in Table 13-2.

Table 13-2: PEA flotation composites

Composite	Drill hole	Interval	
		From (m)	To (m)
M1	H5-15-01Atw	1,115.2	1,130.0
M2	H5-15-01Atw	1,104.9	1,115.2
		1,130.0	1,141.1
M3	H5-15-02Atw	1,010.5	1,027.0
M4	H5-15-02Atw	1,027.0	1,080.5
M5	H5-15-03Dtw	1,255.2	1,389.6
M6	H5-15-05Atw	1,799.5	1,852.5
M7	H5-15-07Btw	1,956.0	1,986.0
M8	H5-15-08Atw	1,443.0	1,550.9
M9	H5-15-09Btw	1,177.0	1,220.7

With reference to Figure 13-1, the spatial distribution of the intercepts involved in the flotation testwork is found to be wider than for the grindability testwork composites.

### 13.1.2 Composite Characterization

The chemical analysis for each of the flotation composites consisted of a screened metallic analysis for Au and Ag at +/-150 mesh. The samples were also subjected to quantitative analysis for Cu, Zn, Fe<sup>2+</sup>, Fe<sup>3+</sup>, S<sub>T</sub>, S<sup>2-</sup> and SO<sub>4</sub>, as well as a four-acid digestion prior to multi-element semi-quantitative ICP scan.

Summaries of the grindability testwork and flotation composite head assays are presented in Table 13-3 and Table 13-4, respectively.

Table 13-3: PEA grindability testwork composites head assays

Composite	Assays					SG
	Au (g/t)	Ag (g/t)	Cu (%)	Zn (%)	S <sup>(1)</sup> (%)	
C1	0.33	1.59	0.07	0.02	6.4	3.0
C2	1.29	20.6	0.12	3.01	41.6	4.5
C3	1.35	14.9	0.08	0.46	11.0	3.2
C4	1.17	13.2	0.15	1.43	25.2	3.8
C5	0.03	1.3	0.01	0.01	< 1.0	2.8 est.
C6	1.42	18.4	0.34	1.32	30.2	4.0

<sup>(1)</sup> Sulphur content estimated from correlation to measured core density or geochemical analysis.

Table 13-4: PEA flotation testwork composites head assays

Composite	Au (g/t)	Ag (g/t)	Cu (%)	Zn (%)	S (%)	Fe (%)	Cd (g/t)	Cr (g/t)	Mn (g/t)	Pb (g/t)
M1	1.24	5	0.42	0.09	23.5	20.5	4	45	10	29
M2	0.64	3	0.19	0.02	8.8	15.7	<2	45	233	30
M3	4.49	46	0.16	1.25	30.5	25.8	39	63	100	196
M4	1.34	31	0.16	1.71	38.2	32.1	53	70	155	270
M5	0.62	15.4	0.11	1.26	25.1	22.8	39	53	703	182
M6	1.89	14.7	0.14	0.82	11.9	12.8	<29	45	888	91
M7	0.55	18.9	0.13	2.43	23.8	22.4	<62	57	366	468
M8	2.25	13.8	0.37	0.66	28.2	24.2	<20	47	99	107
M9	1.55	24.1	0.20	1.09	31.2	28.6	36	65	498	236

### 13.2 Feasibility Study Testwork

The metallurgical test program for the Horne 5 Project FS started in July 2016, under the supervision of BBA and in collaboration with Falco. The metallurgical test plan proposed by BBA was divided into three phases. The third phase was initiated with newly obtained drill core samples at the time of FS preparation. During Phase 1, various tests were conducted using composite samples made of individual samples used during the PEA study. This first segment of the plan aimed at validating the flowsheet developed in the PEA study and generate engineering data for average ore feed grades.

Table 13-5 shows the type of tests performed during Phase 1. As indicated in this table, various laboratories have been involved to execute the test plan: SGS (Lakefield, Ontario) was selected as the main supplier of metallurgical services, namely for the sample handling, bond grindability indices determination and for the flotation and leaching tests; Pocock (Utah, USA) performed the rheology, filtration and settling tests; Cyanco (St-Laurent, Québec) studied the various cyanide destruction processes; Air Liquide (Québec) performed leaching oxygen uptake tests; and Outotec (Pori, Finland) evaluated the regrinding specific energy.

Table 13-5: FS test plan for Phase 1

	Test	Supplier	Samples
Flotation	Rougher kinetics	SGS	SS2021, SS2022, SS2025
	Batch rougher-cleaner test	SGS	
	Lock-cycle test	SGS	
	Flash flotation test	SGS	
Leaching	Leaching test	SGS	SS2025
	O <sub>2</sub> uptake	Air Liquide	
Other	Regrinding	Outotec	SS2025
	Thickening	Pocock	SS2021, SS2022, SS2025
	Slurry rheology	Pocock	
	Filtration	Pocock	
	Cyanide destruction	Cyanco	SS2025

The second phase of the testwork program had, as its main goal, to establish the variability of flotation and leaching performance with ore feed grade variations. All the tests for this phase were performed by SGS, with the exception of Starkey's (Milton, Ontario) involvement in the interpretation of the data obtained from the laboratory procedures related to the SAGDesign tests, as performed by the COREM (Québec, Québec), for establishing the specific grinding energy. Leaching trials were initiated at the time of preparing this Report but no data was yet available for analysis. Table 13-6 shows the type of tests performed during Phase 2.

Table 13-6: FS test plan for Phase 2

	Test	Supplier	Samples
Grinding	Bond work indices	SGS	
	SAGDesign testing	COREM	See Table 13-8
Flotation	Rougher kinetics	SGS	H5-P2-C1 to H5-P2-C6
	Batch rougher-cleaner test	SGS	
	Lock-cycle test	SGS	
Leaching	Leaching test	SGS	

### 13.2.1 FS Sample Selection and Compositing

#### 13.2.1.1 Phase 1

M5 to M9 composites, as prepared during PEA study phase, were blended to provide three master composites: SS2021, SS2022 and SS2025. Large batches of these composites were submitted to flotation and leaching testwork, using the flowsheet developed during the PEA study, to generate sufficient intermediate and final product sample volumes as required for completing equipment sizing testwork with specialized labs and vendors as well as for paste backfill work. The remaining SS2021, SS2022 and SS2025 materials were subjected to additional batch flotation optimization tests as well as some variability testing using the flowsheet defined in the PEA. Finally, a series of leaching optimization tests was performed on the pyrite flotation concentrate and tails, as generated from locked cycle flotation tests, to determine the effect of various parameters on leaching kinetics and metals recovery.

Table 13-7 describes the proportion of each PEA composites used to make the master composites involved in the Phase 1 program.

Table 13-7: FS Phase 1 master composites preparation

Composite	Composite make-up (kg)				
	M5	M6	M7	M8	M9
SS2021		52	6		
SS2022	14				86
SS2025	177			225	



### 13.2.1.2 Phase 2

New core samples from drill hole intervals were selected from the 2015 drill campaign to conduct the Phase 2 of the FS metallurgical testwork program. Table 13-8 summarizes the sample selection process, which collected 25 intervals from various rock types, as deemed relevant for establishing the ore hardness variability within the resource envelope.

Table 13-8: Sample sourcing of FS Phase 2 testwork program

No.	Hole	Sample name	Core intervals	
			From (m)	To (m)
1	01	C15-01-A	1,126.4	1,154.8
2	02	C15-02-A	991.1	1,007.1
3	02	C15-02-B	1,025.1	1,038.1
4	02	C15-02-C	1,007.1	1,019.5
5	02	C15-02-D	1,083.7	1,092.5
6	03B	C15-03B-A	1,253.0	1,261.9
7	03B	C15-03B-A	1,266.5	1,284.1
8	03B	C15-03B-A	1,309.7	1,326.5
9	04	C15-04-A	1,315.5	1,330.5
10	05	C15-05-A	1,816.2	1,831.0
11	05	C15-05-B	1,831.0	1,849.0
12	05	C15-05-C	1,849.0	1,865.5
13	05	C15-05-D	1,865.5	1,883.0
14	06	C15-06-A	1,198.0	1,219.5
15	06	C15-06-B	1,222.7	1,236.5
16	07	C15-07-A	1,098.2	1,127.9
17	07A	C15-07A-A	1,956.0	1,970.0
18	07A	C15-07A-B	1,970.0	1,981.4
19	08	C15-08-A	703.0	719.8
20	08	C15-08-B	719.8	732.5
21	08	C15-08-C/D	1,420.0	1,459.0
22	08	C15-08-E/F	1,496.0	1,526.0
23	08	C15-08-G	1,533.0	1,549.9
24	09A	C15-09A-A	1,180.5	1,199.5
25	09A	C15-09A-B	1,203.8	1,218.8

These 25 samples were submitted to full SAGDesign indices determination program (SAG<sub>std</sub> and Sd-BWi). Additionally, RWi, BWi and Ai testing was conducted at SGS on the remaining samples, where residual sample weights made it possible. The unused residual coarse material from the SAGDesign determinations tests and the RWi rejects from SGS were recombined, for each of the respective intervals presented in the Table 13-8.

These coarse samples were then used to prepare six composites covering a reasonable range of the metal grades for gold, silver, copper, zinc and sulphur expected to be processed. The metallurgical testwork completed with these included confirmation of the flowsheet developed and optimization work in flotation and leaching. Table 13-9 shows the recipe applied for preparing each composite.

Table 13-9: Phase 2 composite samples preparation

Samples included in blends	Composites definition and weights (kg)					
	H5-P2-C1	H5-P2-C2	H5-P2-C3	H5-P2-C4	H5-P2-C5	H5-P2-C6
C15-02-D + C15-02-A			25			
C15-02-B + C15-07A-B						5
C15-02-C + C15-03B-A/B-B/B-C + C15-09A-A	20	100				
C15-04-A + C15-06-A					50	
C15-05-B					20	
C15-05-A/C/D + C15-07A-A + C15-08C + C15-08-E/F	70			100		85
C15-06-B			75			
C15-07-A						10
C15-08-B					30	
C15-09A-B	10					
<b>Final composite weights</b>	<b>60</b>	<b>99</b>	<b>40</b>	<b>50</b>	<b>60</b>	<b>50</b>

### 13.2.2 FS Samples Head Assays

Composite samples prepared for FS testwork programs were submitted to screened metallic analysis for gold and silver, at +/-150 mesh. The samples were also subjected to quantitative analysis for copper, zinc and total sulphur (“S<sub>T</sub>”). Semi-quantitative ICP scans for multi-element analysis were also performed. Table 13-10 summarises the results for major elements and trace elements of interest.

Table 13-10: Head assays for composite samples

Sample name	Assays (weighted average)						
	Au (g/t)	Ag (g/t)	Cu (%)	Zn (%)	Fe (%)	S (%) <sup>(1)</sup>	S (%) <sup>(2)</sup>
C15-01-A	1.42	8.6	0.63	0.06	16.0	18.3	10.2
C15-02-A	0.62	6.5	0.04	0.21	7.8	9.0	6.6
C15-02-B	1.47	49.9	0.15	3.97	24.2	30.3	42.7
C15-02-C	1.66	26.0	0.11	1.17	16.5	19.6	20.3
C15-02-D	0.40	8.7	0.03	1.08	13.2	15.9	0.9
C15-03B-A	1.19	38.0	0.14	2.05	23.8	28.6	30.3
C15-03B-A	0.30	11.7	0.05	0.68	13.8	16.2	19.0
C15-03B-A	0.58	23.2	0.10	1.29	15.4	18.5	29.7
C15-04-A	0.64	10.0	0.20	0.50	25.6	29.7	27.5
C15-05-A	3.93	17.3	0.15	0.73	12.7	15.0	8.8
C15-05-B	2.28	15.0	0.10	0.73	10.0	11.9	11.1
C15-05-C	1.56	15.8	0.12	0.46	10.9	12.8	12.5
C15-05-D	0.93	15.1	0.06	0.56	12.7	14.9	14.6
C15-06-A	1.87	16.6	0.26	0.45	18.7	21.7	28.4
C15-06-B	1.12	22.7	0.29	1.35	25.2	29.7	48.3
C15-07-A	4.41	25.9	0.60	2.23	22.4	27.1	21.8
C15-07A-A	0.33	8.7	0.12	0.87	12.1	14.4	11.5
C15-07A-B	0.51	28.8	0.09	3.55	25.8	31.9	46.8
C15-08-A	7.20	19.7	0.19	3.96	25.5	31.8	30.1
C15-08-B	1.22	7.6	0.14	1.98	15.0	18.5	10.3
C15-08-C/D	1.34	6.6	0.10	0.23	9.7	11.3	10.9
C15-08-E/F	1.34	7.2	0.15	0.29	13.6	15.8	16.8
C15-08-G	2.38	27	0.66	0.4	24.5	28.3	41.1
C15-09A-A	1.23	26.6	0.19	1.61	20.7	24.8	32.0
C15-09A-B	2.89	47.6	0.47	0.60	24.9	28.8	40.2

<sup>(1)</sup> Sulphide content inferred from correlation to measured core density or geochemical analysis. Sulphide content converted to sulphur content by associating all sulphur content to pyrite mineralogy.

<sup>(2)</sup> Sulphur content for feasibility samples measured from chemical analysis.

As per Table 13-10, the sulphide content inferred is not aligned with the assayed values. This discrepancy, at times, introduces a bias between the indicated lithology of the intercepts, which was the only information available at the time of sample selection, and their actual nature, per the assayed sulphur content.

### 13.2.3 Lithology

The mineralization found within the resource envelope is broadly defined as sulphides deposited within a rhyolitic host. At times, the sulphides represent the bulk of the mineralized sections, defined as massive sulphides, but occurrences where the sulphides represent a lower fraction of the mineralized areas are more common. In these instances, the rhyolitic host rock can be present as either a tuff, breccia, or as massive rhyolite. The proportions of each type found in the resource envelope are as yet to be defined.

The overall resource outline, as established in the November 2016 MRE, was divided into six mineralized envelopes (ENV\_A to ENV\_F), of which ENV\_A was the main contributor to the resource estimate. ENV\_B to ENV\_F represented smaller zones, mostly outlined for their higher gold content (see Figure 13-2).

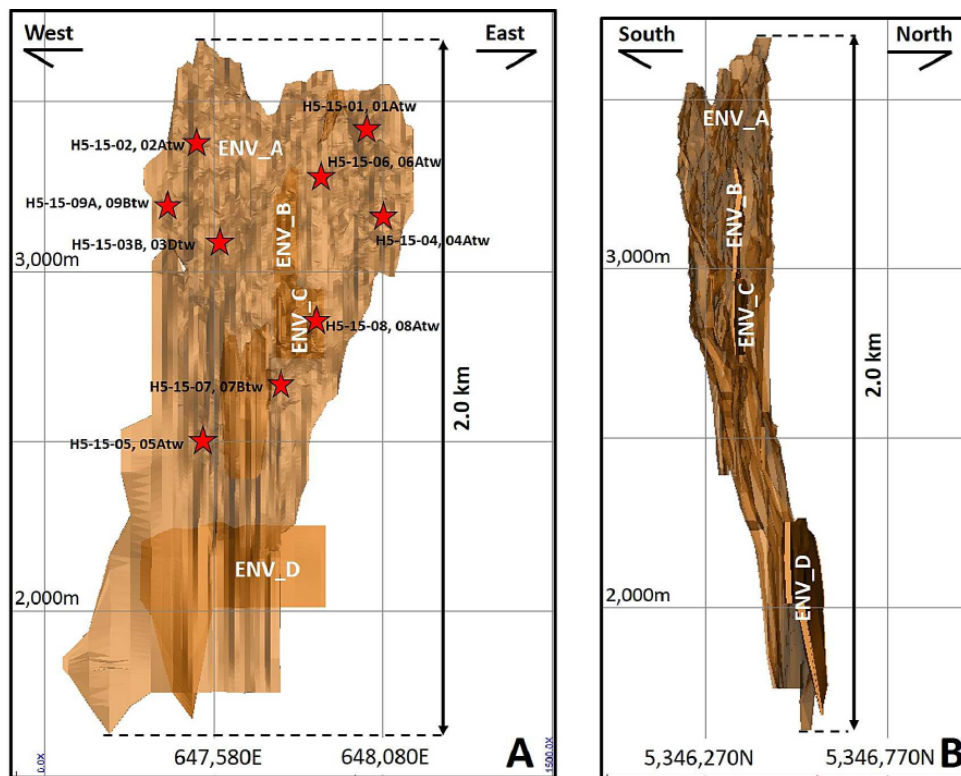

Figure 13-2: Sections showing main resource envelope  
 (Source: InnovExplo, November 2016 MRE)

Within ENV\_A, high-grade zones were identified for gold, copper, zinc, or sulphides (using the specific gravity, SG, as a proxy for sulphide content, mostly present in the form of pyrite). The outlines of these zones are presented in Figure 13-3 to Figure 13-6.

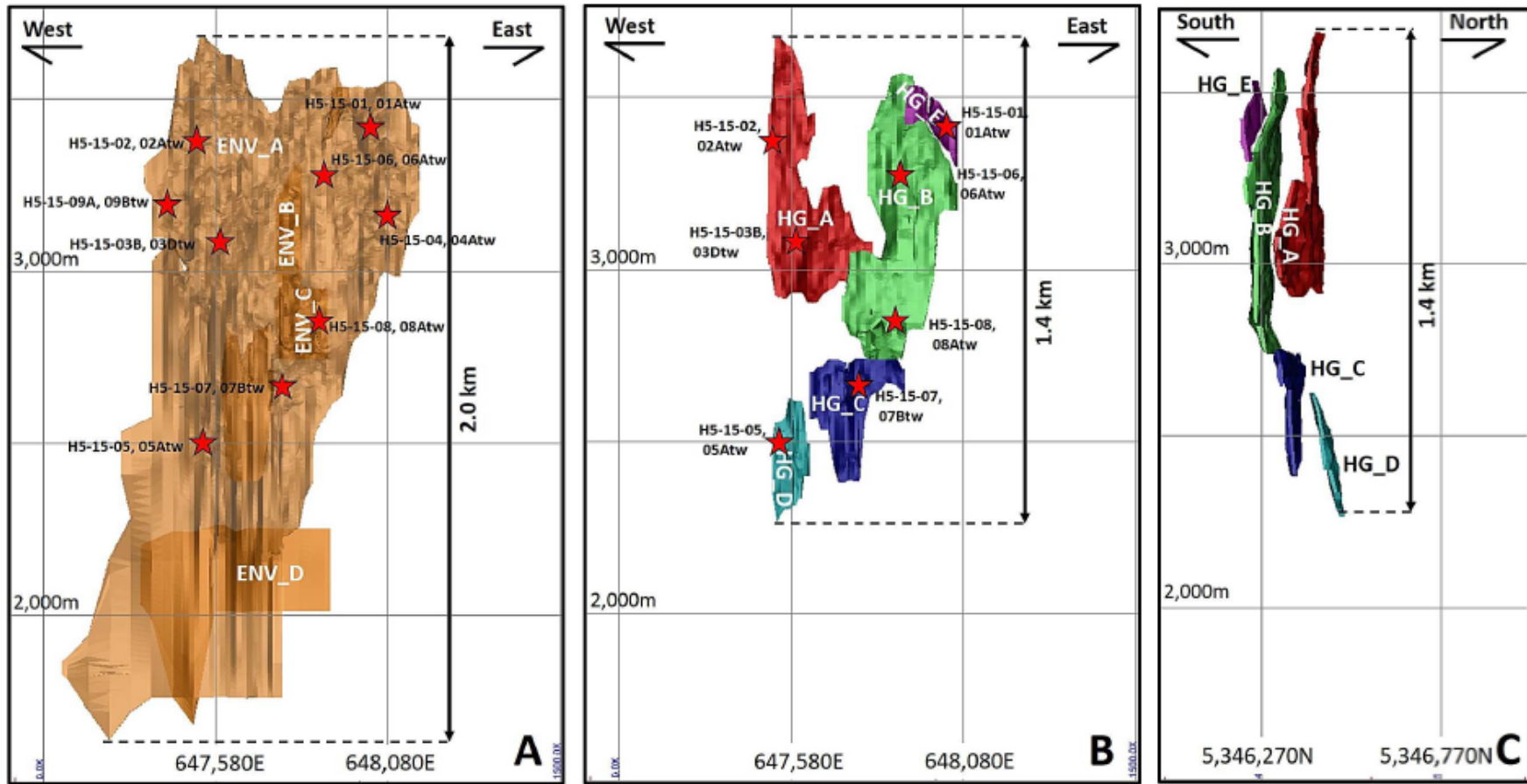

Figure 13-3: Sections showing high-grade Au zones within main resource envelope  
 (Source: InnovExplo, November 2016 MRE)

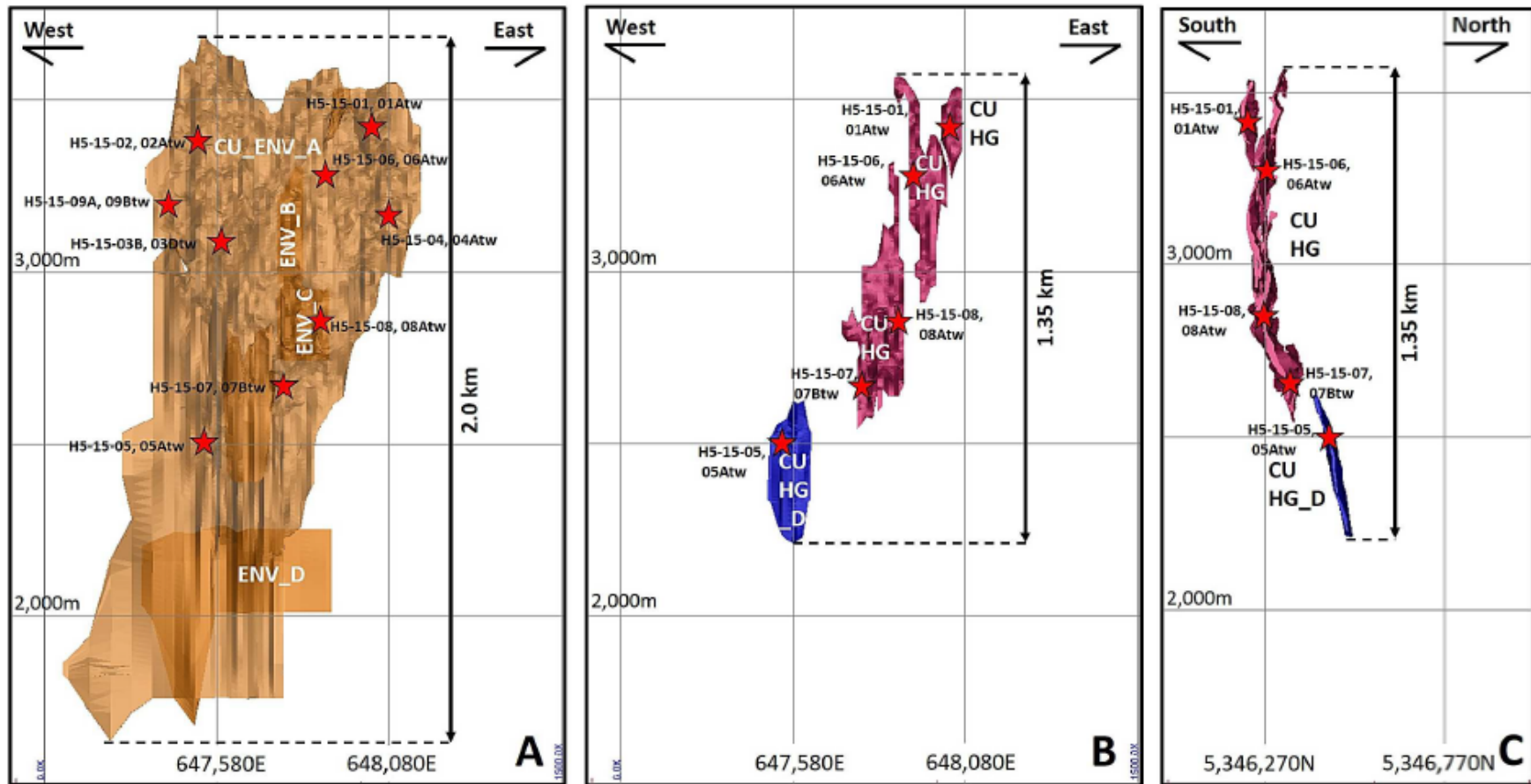

Figure 13-4: Sections showing high-grade Cu zones within main resource envelope  
 (Source: InnovExplo, November 2016 MRE)



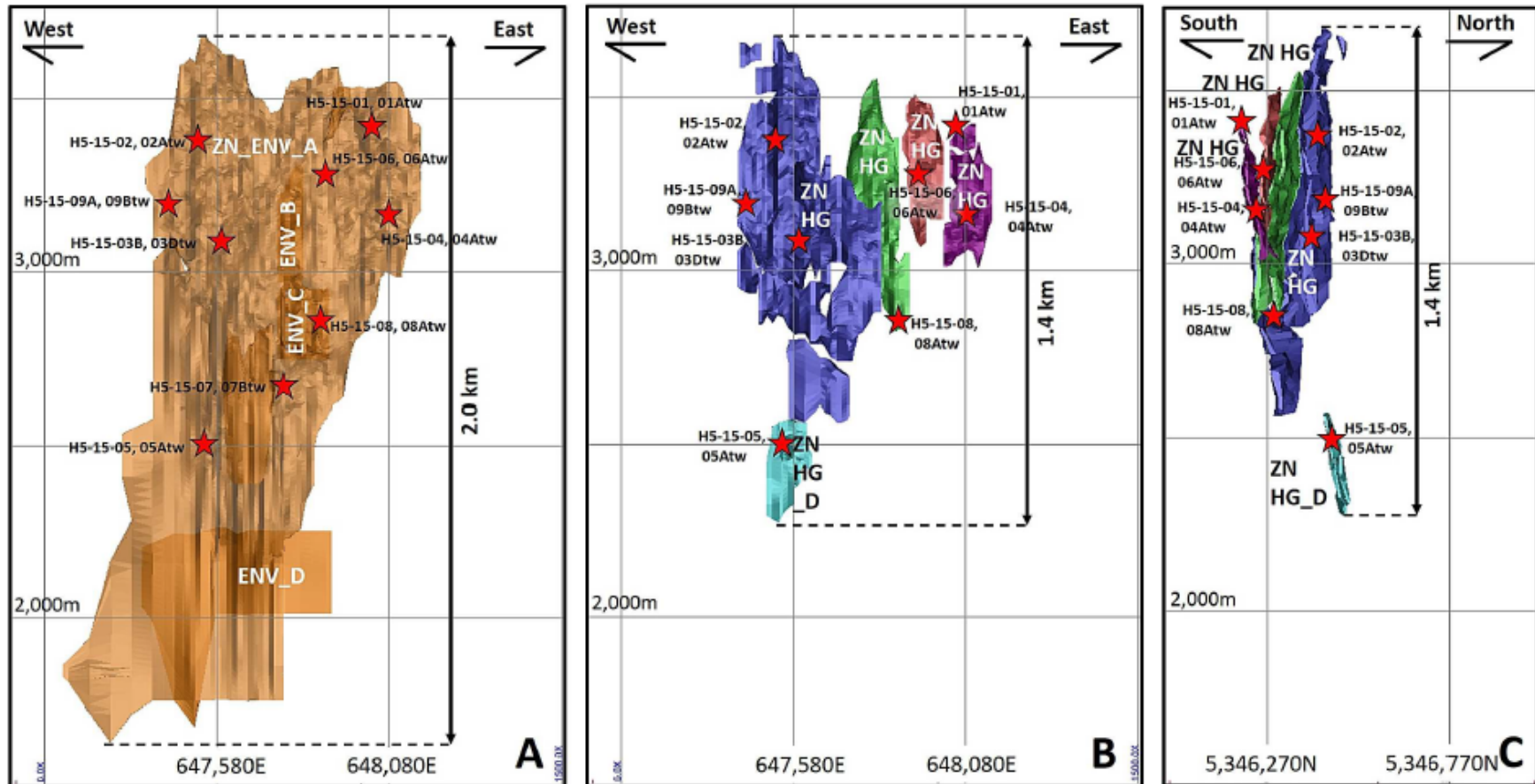

Figure 13-5: Sections showing high-grade Zn zones within main resource envelope  
(Source: InnovExplo, November 2016 MRE)



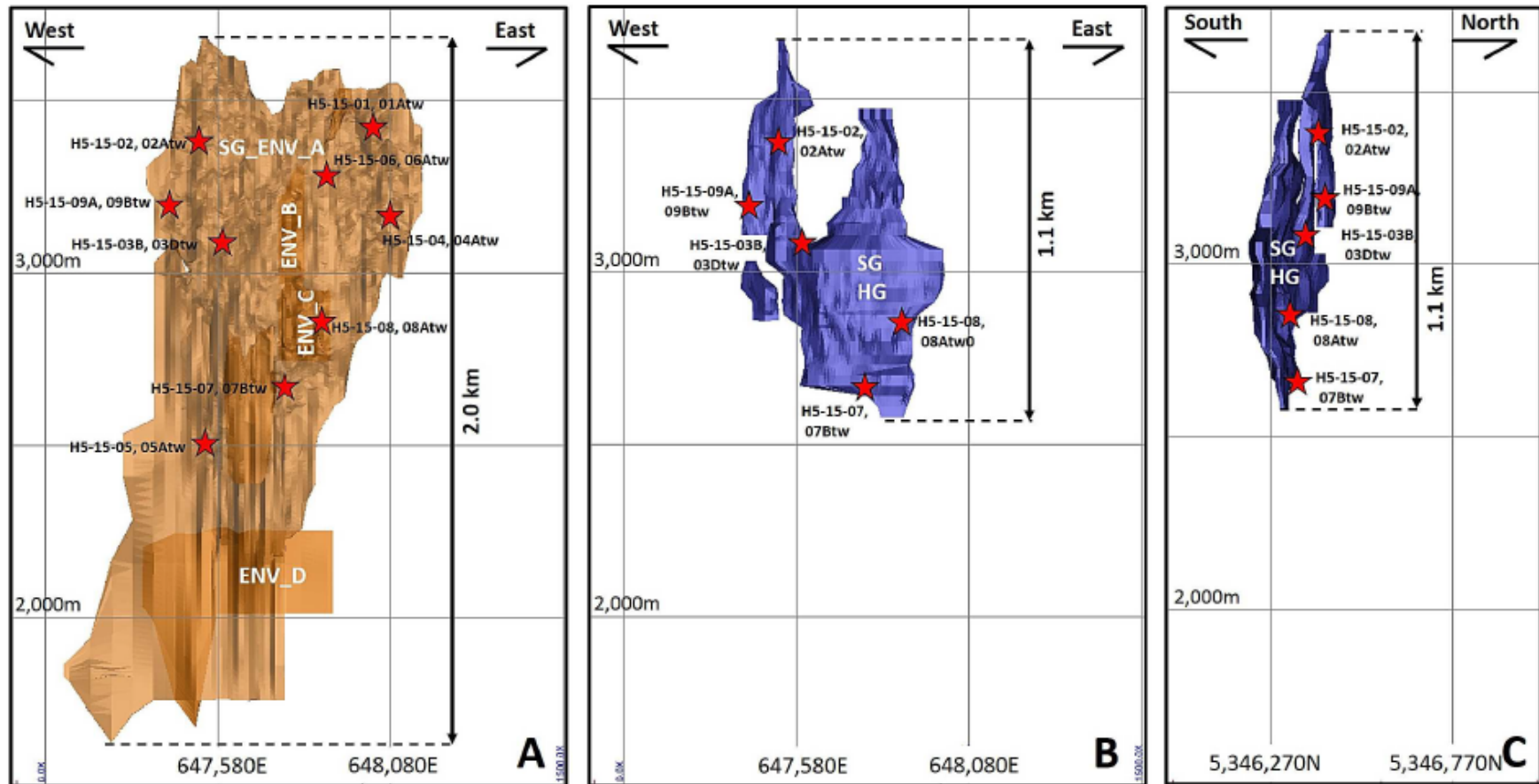

Figure 13-6: Sections showing high-grade sulphide zones within main resource envelope  
 (Source: InnovExplo, November 2016 MRE)

The proportion of sulphides present in the intercepts, included in the metallurgical composites, has been assessed from:

- The core logs;
- The sulphur assays from testwork data;
- Projected sulphur content based on mineralogical conversion of copper, zinc and iron assays into chalcopyrite, sphalerite and pyrite; or
- A correlation linking sulphur content to measured core SG, developed by the exploration team.

The presence of magnetite in some portions of the resource envelope make the last two methods potentially biased at times as some of the iron may be present as magnetite and the SG measured when this mineral is present will be higher, without necessarily representing a higher sulphide content. Proper assaying of the cores for sulphur would thus be required to confirm the sulphide content, at least wherever magnetite is present.

Table 13-11 presents the lithologies associated with the grindability composites, as well as an indication of their relative sulphide content. The pierce points of the 2015 drilling campaign, illustrated in Figure 13-2 to Figure 13-6 are indicative of whether the intercepts included in the metallurgical composites were taken from some of the high-grade zones.

**Table 13-11: Grindability testwork composite lithology**

Composite	Indicated Lithology	% Sulphide
<b>PEA<sup>(1)</sup></b>		
C1	100% Rhyolitic tuff	12
C2	100% Massive sulphide	89
C3	100% Rhyolitic breccia	34.6
C4	33% Semi-massive sulphide, 33% rhyolitic lapilli to bloc tuff, 33% massive sulphide	64
C5	100% Rhyolitic fine to coarse tuff	1.4
C6	100% Massive sulphide	70.6
<b>Feasibility Study<sup>(2)</sup></b>		
C15-01-A	Rhyolite; Breccias01-Undefined	19.8
C15-02-A	Rhyolitic tuff	12.4
C15-02-B	Massive sulphides	82.4
C15-02-C	Rhyolitic tuff; Rhyolite; Breccias01-Undefined	38.8
C15-02-D	Diorite	2.3
C15-03B-A	Massive sulphides; Rhyolitic tuff	58.0

Composite	Indicated Lithology	% Sulphide
C15-03B-B	Rhyolitic fine to lapilli tuff 55°; Semi-MS; Rhyolitic bloc tuff	36.0
C15-03B-C	Rhyolitic coarse to lapilli tuff; Polymictic, Polygenic; Semi-MS	56.4
C15-04-A	Semi-MS; Mafic intrusive rocks	51.9
C15-05-A	Rhyolite; Massive; Breccias01-Undefined	17.0
C15-05-B	Massive sulphides	21.3
C15-05-C	Rhyolite; Massive; Breccias01-Undefined	23.8
C15-05-D	Massive sulphides	27.7
C15-06-A	Massive sulphides	53.7
C15-06-B	Massive sulphides	91.5
C15-07-A	Rhyolite; Breccias01-Undefined	42.7
C15-07A-A	Rhyolitic fine to lapilli tuff; Schistose, Schistosity; Rhyolite; Breccias01-Undefined	22.2
C15-07A-B	Massive sulphides	89.8
C15-08-A	Massive sulphides	58.9
C15-08-B	Rhyolitic fine to coarse tuff; Semi-MS	20.6
C15-08-C/D	Rhyolitic fine to coarse tuff	20.6
C15-08-E/F	Rhyolitic fine tuff	31.8
C15-08-G	Massive sulphides	79.3
C15-09A-A	Rhyolitic fine to lapilli tuff	61.0
C15-09A-B	Massive sulphides	76.0

(1) Sulphide content inferred from chemical analysis. Sulphur content calculated from sulphide content by associating all sulphur to pyrite.

(2) Sulphur content for feasibility samples measured from chemical analysis. Sulphide content inferred from mineralogical sulphur content, with Cu and Zn assays converted to chalcopyrite and sphalerite, respectively, and the balance of sulphur assigned to pyrite.

As indicated in Table 13-11, composite C2 incorporated an intercept within a high-grade zinc area, outlined in violet in Figure 13-5, and was in a high sulphide area, as seen in Figure 13-6.

Table 13-12 presents the derived massive sulphide content, per flotation composite.

Table 13-12: Flotation testwork composites zone and % sulphide

Composite	% Sulphide <sup>(1)</sup>
M1	44.4
M2	16.7
M3	58.0
M4	72.6
M5	47.8
M6	22.9
M7	44.7
M8	53.4
M9	59.2
SS2021	23.4
SS2022	45.7
SS2025	59.3
H5-P2-C1	34.4
H5-P2-C2	49.7
H5-P2-C3	66.1
H5-P2-C4	22.8
H5-P2-C5	36.7
H5-P2-C6	27.1

<sup>(1)</sup> Sulphide content inferred from sulphur content, with Cu and Zn assays converted to chalcopyrite and sphalerite, respectively, and the balance of sulphur assigned to pyrite.

#### 13.2.4 Head Samples Mineralogy

The flotation composites M1-M9, with the exception of M8 (not studied for lack of material), were submitted for mineralogical analysis, including QEMSCAN (quantitative evaluation of materials by scanning electron microscopy), along with a gold deportment study. The objectives of the characterization program were to determine:

- Bulk mineralogy;
- Sulphides mineral association and grain size;
- Gold carriers and their modes of occurrence;
- Mineralogical characteristics that could inhibit gold recovery.

The 25 new composite samples for the feasibility test program were not submitted to mineralogical study.

## Bulk Mineralogy

All composites studied were comprised mainly of pyrite and quartz, with minor amounts of other minerals. A more detailed mineral make-up of each composite is presented in Table 13-13.

Table 13-13: Bulk mineralogy of flotation testwork composites

Composite	M1	M2	M3	M4	M5	M6	M7	M9
Pyrite/Marcasite	42.0	15.6	55.0	66.0	49.6	50.8	94.5	93.0
Quartz	32.1	35.3	28.3	19.3	15.9	16.1	1.4	0.9
Fe-Oxides	<0.1	8.7	<0.1	<0.1	0.21	0.2	0.1	0.1
Sericite/Muscovite	15.5	13.7	5.8	4.8	4.7	4.6	0.5	0.2
Plagioclase	0.3	9.2	1.0	0.7	1.0	0.9	0.1	0.1
Chlorite/Clays	2.8	8.7	4.4	3.2	5.2	7.0	0.5	0.5
Chalcopyrite	1.1	0.7	0.5	0.5	8.8	8.9	0.04	0.1
Sphalerite	0.2	<0.1	2.6	3.1	10.1	7.5	2.6	4.7
Others	6.0	8.1	2.4	2.4	0.5	0.2	0.1	0.1

## Gold Department

A mineralogical analysis completed on the nine composites identified the main gold minerals present, as well as a number of other unidentified Au-Ag-Te minerals. These can be broadly divided in two main groups:

- Native Au-Ag blends:
  - Native gold – Au
  - Electrum – (Au, Ag) where Ag > 20%
  - Kustelite – (Ag, Au) with 10% < Au < 30%
- Tellurides:
  - Calaverite – AuTe<sub>2</sub>
  - Petzite – (Ag, Au)<sub>2</sub>Te
  - Muthmannite – (Ag, Au)Te
  - Sylvanite – (Au, Ag)Te<sub>2</sub>
  - Hessite – Ag<sub>2</sub>Te

The average gold grain size was measured to be between 2.2 µm and 3.22 µm for all composites, with the coarsest value registered with M5, at only 5.5 µm. The fine nature of the gold thus prevents consideration of a gravimetric recovery approach.

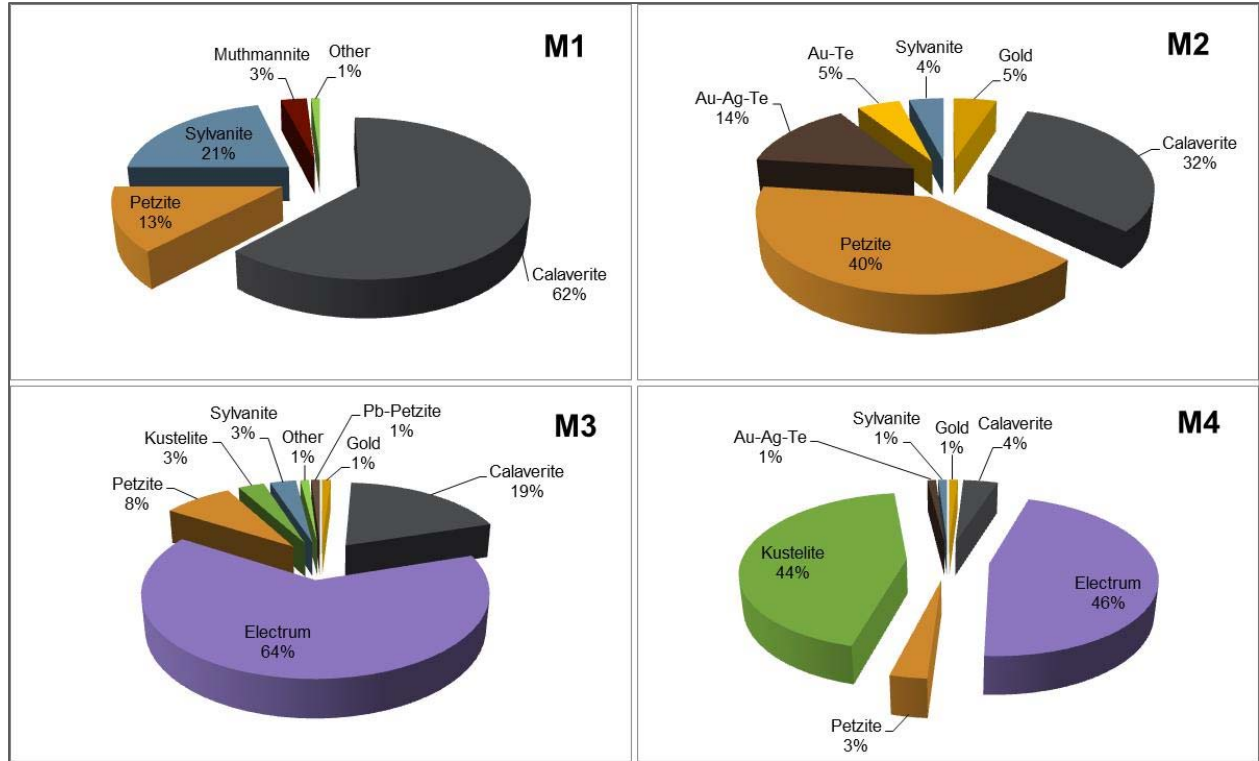

Figure 13-7: Mineralogical distribution of gold occurrences in flotation composites M1 to M4

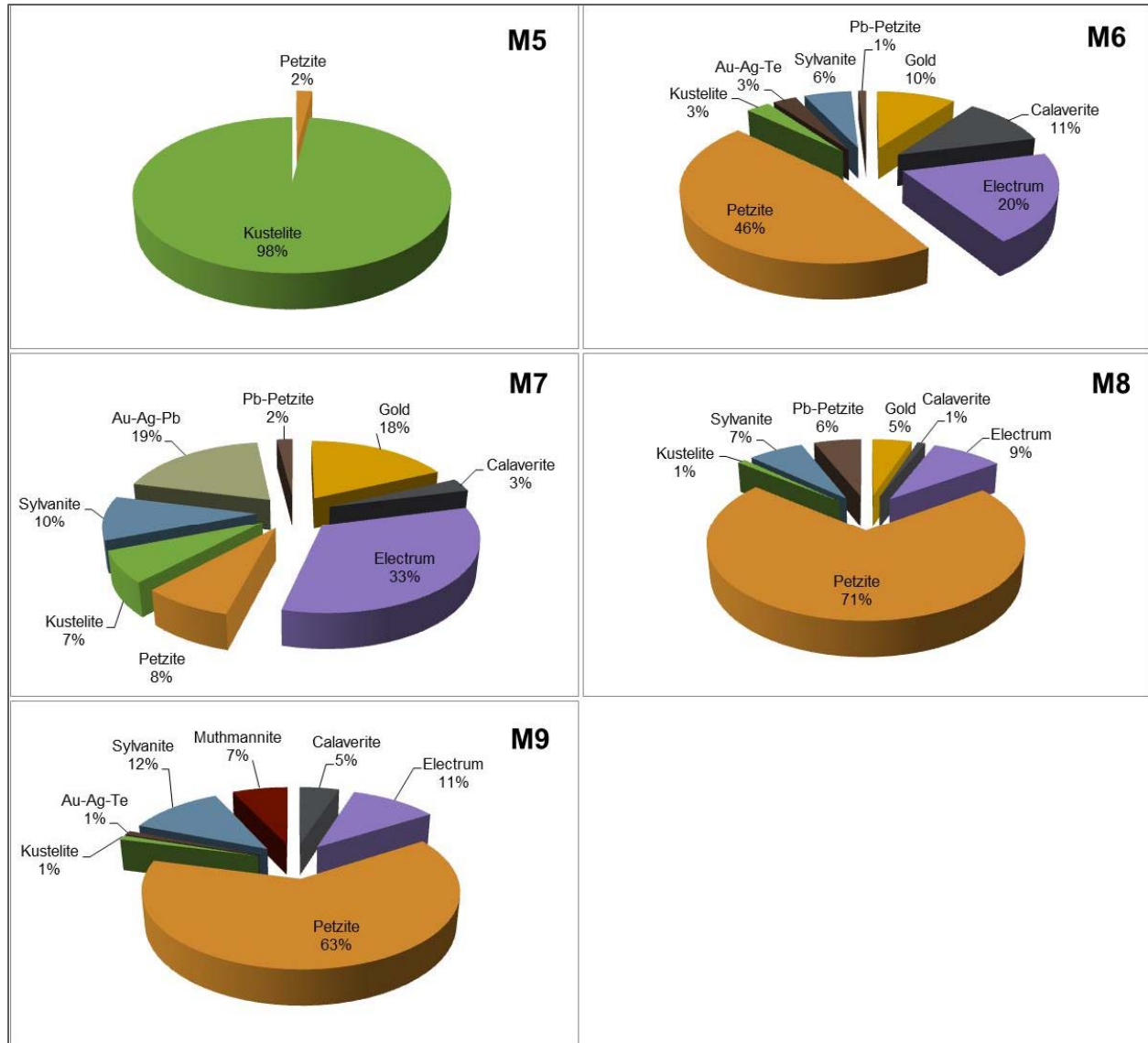

Figure 13-8: Mineralogical distribution of gold occurrences in flotation composites M5 to M9

As illustrated in Figure 13-7 and Figure 13-8, six of the composites had a concentration of tellurides higher than 66% as gold carriers, with four of these being over 80%.

A gold deportment study was reported for all flotation composites (M1-M9). As shown in Figure 13-9, the study indicated that the amounts of liberated and exposed gold varied significantly between samples from as little as 4% in M2 to as much as 75% in M3. The gold deportment study was conducted at a P<sub>80</sub> of 150 µm.



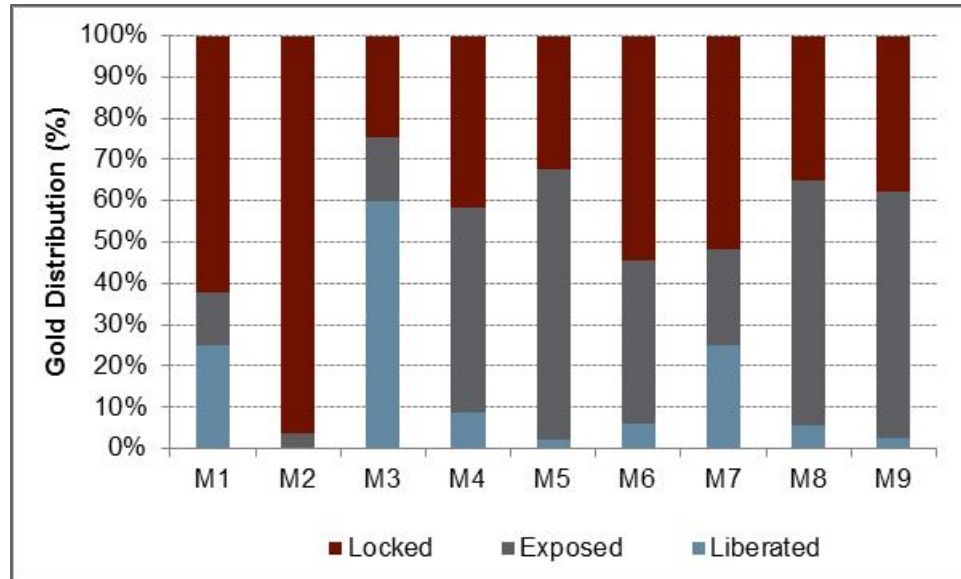

Figure 13-9: Gold liberation study for composites M1 to M4

The native Au-Ag blends should be mostly recoverable by flotation when present, either as occluded/included particles within sulphides, or as liberated particles as long as tarnishing of the exposed surfaces does not passivate the minerals. Gold included within non-sulphide matrix could be recovered via cyanidation of the pyrite flotation tailings, as long as the gold is exposed to the cyanide solution.

The gold carried by tellurides should also behave similarly to the Au-Ag blends in the flotation circuits, although these carriers may be more prone to tarnishing. Gold recovery through cyanidation of the tellurides typically requires a long retention time, high addition of cyanide and potentially a high level of dissolved oxygen, only made available through the use of pure oxygen as the oxidant within the cyanidation circuit, instead of air. For all these reasons, deportment of the tellurides into the copper concentrate is the favoured approach to reduce operating costs within the cyanidation circuit of the pyrite concentrate and ensure recovery at the front-end of the process.

No additional mineralogy was carried out for the FS phase.

### 13.3 Comminution Testwork

Composite C1 to C3 from the PEA and 25 other samples from the FS were submitted to Starkey testing for full SAGDesign program. This test consisted of a two-stage grind. The secondary grind was closed with a 74 µm screen to achieve a product size close to the flowsheet target P<sub>80</sub> of 50-55 µm.

Additionally, all composite from the PEA study and 16 samples on the 25 FS composites were also submitted to RWi and BWi work indices, and Ai determinations at SGS. Refer to Table 13-11 for associated lithology for each sample. Table 13-14 and Table 13-15 are showing the grindability testwork results.

Table 13-14: Summary of SAGDesign and bond comminution test results from PEA study

Sample Identification	SGS				Starkey			
	RWi (kWh/t)	BWi (kWh/t)	Ai (g)	%S	%S	SG	Wstd (kWh/t)	BWi (kWh/t)
C-1	21.2	21.5	1.1	6.4				
C-2	10.2	7.5	0.4	47.5				
C-3	17.3	16.1	0.5	18.5				
C-4						2.7	20.6	20.4
C-5						3.8	7.7	14.7
C-6						3.8	7.6	12.3

Table 13-15: Summary of SAGDesign and bond comminution test results from FS testwork

Sample Number	Sample Identification	SGS				Starkey			
		RWi (kWh/t)	BWi (kWh/t)	Ai (g)	%S	%S	SG	Wstd (kWh/t)	BWi (kWh/t)
SA1	C15-01-A	18.4	16.2		9.3	10.2	3.2	14.4	15.8
SA2	C15-02-A					6.6	3.1	17.3	20.1
SA3	C15-02-B					42.7	4.2	5.4	10.9
SA4	C15-02-C					20.3	3.3	11.1	14.4
SA5 <sup>(1)</sup>	C15-02-D								
SA6	C15-03B-A	14.1	13.8		26.0	30.3	3.8	9.1	13.4
SA7	C15-03B-B	16.7	14.9	0.5	19.5	19.0	3.2	13.6	15.1
SA8	C15-03B-C	14.2	14.0	0.5	26.2	29.7	3.7	9.4	14.4
SA9	C15-04-A	13.6	13.8	0.4	29.5	27.5	3.8	10.6	13.9
SA10	C15-05-A					8.8	3.0	15.9	15.6
SA11	C15-05-B	16.2	15.0	0.4	10.3	11.1	3.1	11.4	14.5
SA12	C15-05-C	17.0	16.2	0.7	11.9	12.5	3.0	12.7	15.7
SA13	C15-05-D	15.9	15.1	0.5	15.0	14.6	3.1	11.7	14.8
SA14	C15-06-A	14.3	13.6	0.4	26.6	28.4	3.6	10.6	14.0
SA15	C15-06-B	8.7	10.4	0.4	48.5	48.3	4.7	5.5	11.8
SA16 <sup>(2)</sup>	C15-07-A	14.3	13.3	0.3	23.2	21.8	3.6	9.4	14.1
SA17 <sup>(2)</sup>	C15-07A-A	18.3	16.8	0.5	8.5	11.5	3.7	14.6	16.2
SA18	C15-07A-B	8.4		0.3		46.8	4.7	4.2	10.6

Sample Number	Sample Identification	SGS				Starkey			
		RWi (kWh/t)	BWi (kWh/t)	Ai (g)	%S	%S	SG	Wstd (kWh/t)	BWi (kWh/t)
SA19	C15-08-A	12.5			29.9	30.1	3.8	9.1	11.0
SA20	C15-08-B					10.3	3.1	13.3	15.5
SA21	C15-08-C/D	17.9	16.7	0.6	12.1	10.9	3.0	15.1	16.2
SA22	C15-08-E/F			0.4		16.8	3.3	11.7	12.8
SA23	C15-08-G					41.9	4.3	7.9	10.8
SA24	C15-09A-A		13.1	0.4	30.9	32.0	3.9	8.5	14.1
SA25	C15-09A-B	11.9	10.9	0.4	42.4	40.2	4.1	7.0	11.6

- (1) Samples SA5 show outstanding hardness numbers. This sample represents diorite coming from a dike, a waste material.
- (2) Starkey results shown for SA16 and SA17 have been inverted since samples have likely been mixed during testwork.

When comparing sulphur assays for both SGS and Starkey’s samples, it shows samples analyzed were very similar and homogeneous.

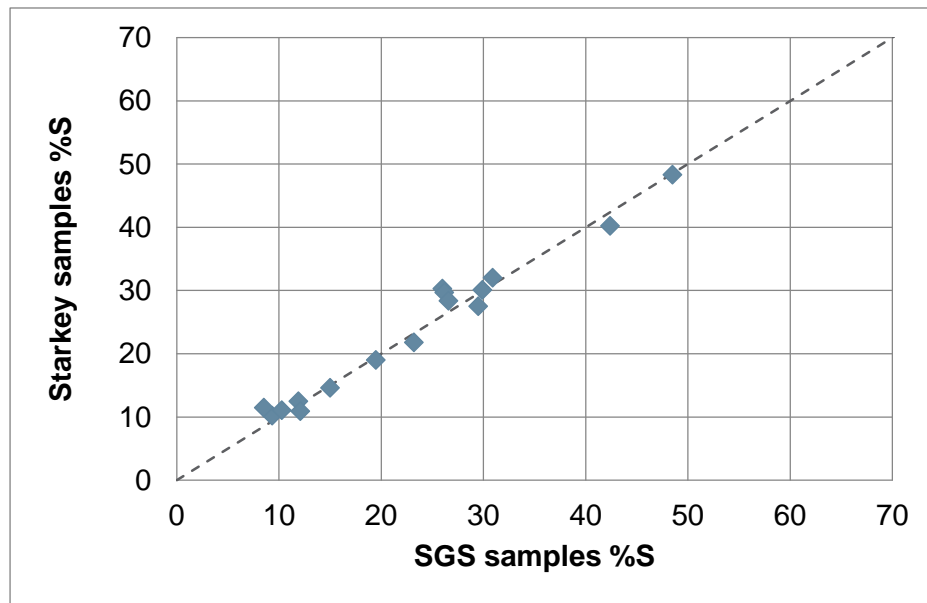

Figure 13-10: Comparison of grindability samples sulphur assays

Table 13-16 below presents the statistics derived from the PEA and FS grindability data set.

Table 13-16: Grindability testwork statistics

Project Phase	Statistics	SGS				Starkey			
		RWi (kWh/t)	BWi (kWh/t)	Ai (g)	%S	%S	SG	Sd-W <sub>std</sub> (kWh/t)	Sd-BWi (kWh/t)
All	Average	14.8	14.4	0.5	23.3	23.8	3.6	10.9	14.2
	Std dev	3.4	3.0	0.2	12.9	13.1	0.5	3.9	2.4
	80 <sup>th</sup> percentile	17.5	16.2	0.5	30.3	35.3	3.9	14.3	15.7
	Minimum	8.4	7.5	0.3	6.4	6.6	2.7	4.2	10.6
	Maximum	21.2	21.5	1.1	48.5	48.3	4.7	20.6	20.4
PEA only	Average	16.2	15.0	0.7			3.4	12.0	15.8
	Std dev	5.6	7.1	0.4			0.6	7.5	4.2
	80 <sup>th</sup> percentile	19.6	19.3	0.8			3.8	15.4	18.1
	Minimum	10.2	7.5	0.4			2.7	7.6	12.3
	Maximum	21.2	21.5	1.1			3.8	20.6	20.4
FS only	Average	14.5	14.3	0.4	23.1	23.8	3.6	10.8	14.0
	Std dev	3.1	1.9	0.1	11.8	13.1	0.5	3.5	2.2
	80 <sup>th</sup> percentile	17.0	16.2	0.5	29.9	35.3	4.0	13.9	15.7
	Minimum	8.4	10.4	0.3	8.5	6.6	3.0	4.2	10.6
	Maximum	18.4	16.8	0.7	48.5	48.3	4.7	17.3	20.1

The RWi and the BWi for both PEA and FS average, respectively, 14.8 kWh/t and 14.4 kWh/t. The hardest values at respectively 21.2 kWh/t and 21.6 kwh/t corresponding to sample C1 (Rhyolite) measured during the PEA, and the minimum values measured are respectively 8.4 kWh/t and 7.5 kWh/t (massive sulphide), showing the wide range in hardness characterizing the ore body. The average total SAG grindability index (“Sd-Wstd”) and the ball mill pinion energy (“Sd-BWi”) determined by Starkey are respectively 10.9 kWh/t and 14.2 kWh/t with the highest values at respectively 20.6 kWh/t and 20.4 kWh/t and minimum values at respectively 4.2 kWh/t and 10.6 kWh/t. Similarly to RWi and BWi, the specific energies evaluated by Starkey covers also a wide range of values. This wide range of values shown for both sets of indices is easily explainable by the strong relation between hardness and sulphur content, with the first one increasing as the sulphide content (and resulting SG) decreases. Thereby, the massive sulphides and the low-sulphide content rhyolitic tuff are at each extreme and the mineralized breccia falls in-between. Figure 13-11 to Figure 13-16 illustrate those relations, whereas Figure 13-17 and Figure 13-18 present the statistical distribution of the Sd-Wstd and Sd-BWi indices measured.

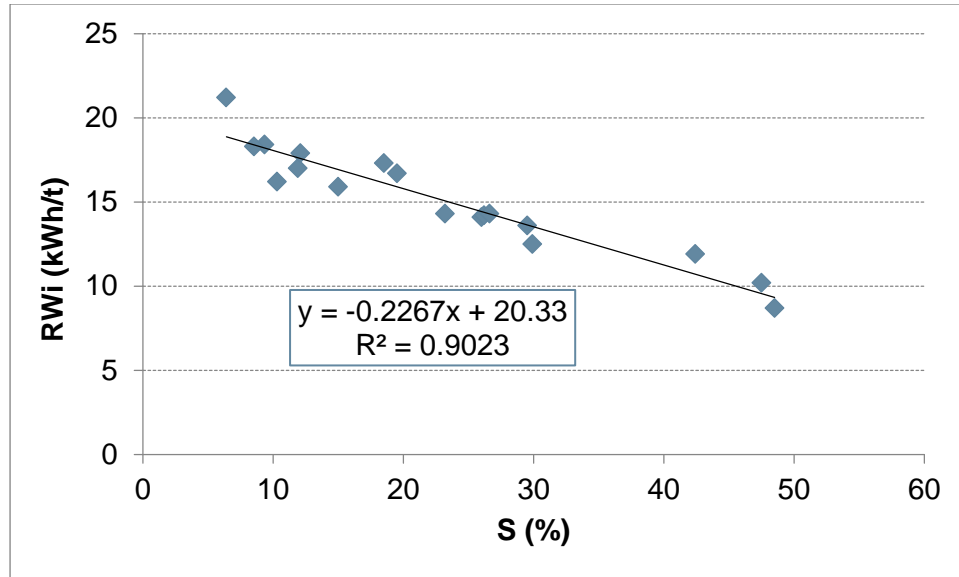

Figure 13-11: Relation between bond rod mill work index and sulphur grade

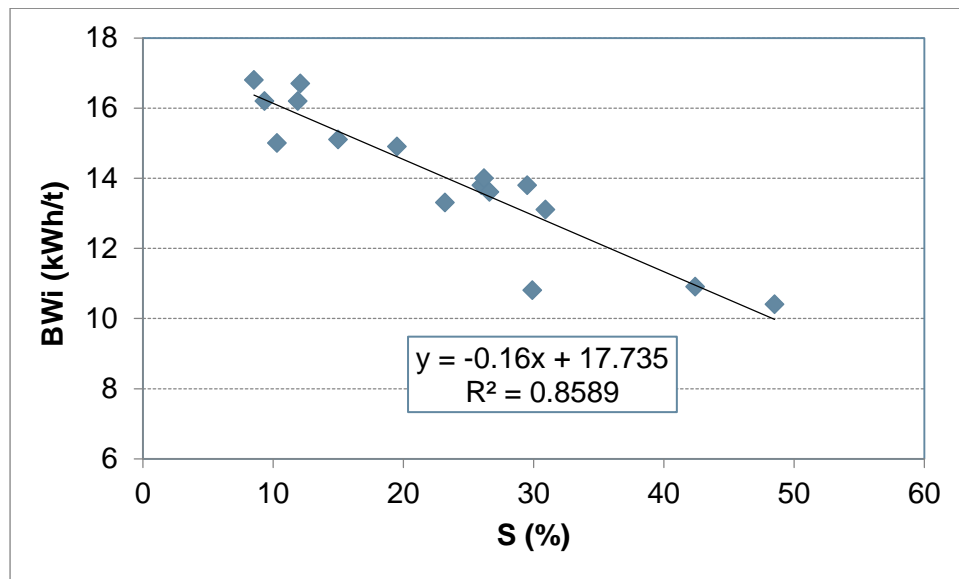

Figure 13-12: Relation between bond ball mill work index and sulphur grade (150M closing sieve)

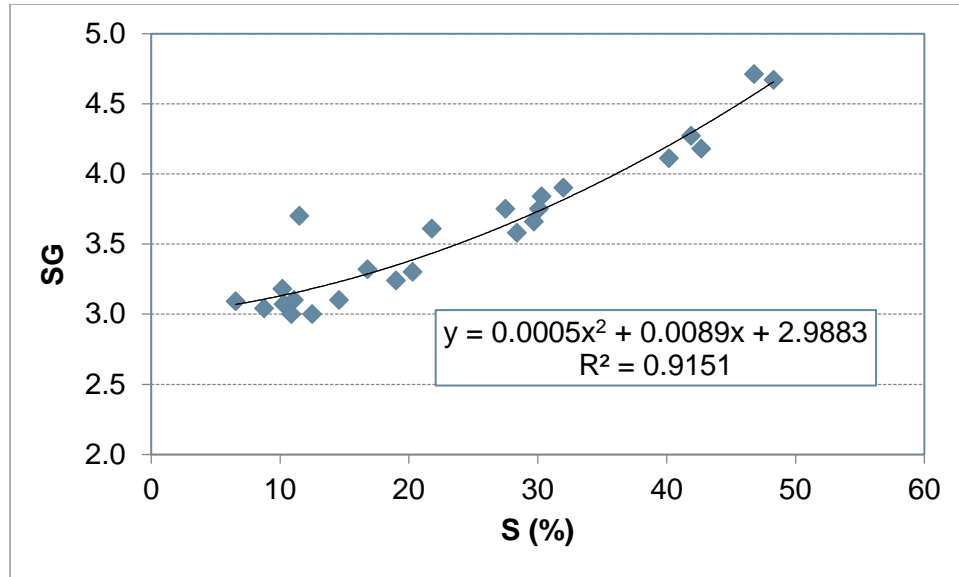

Figure 13-13: Relation between rock specific gravity and sulphur grade

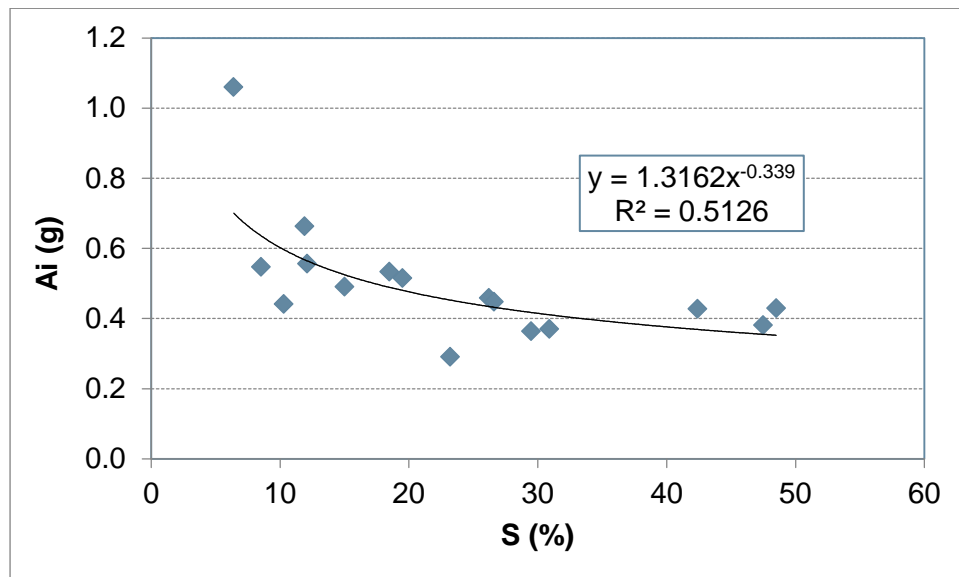

Figure 13-14: Relation between abrasion index and sulphur grade

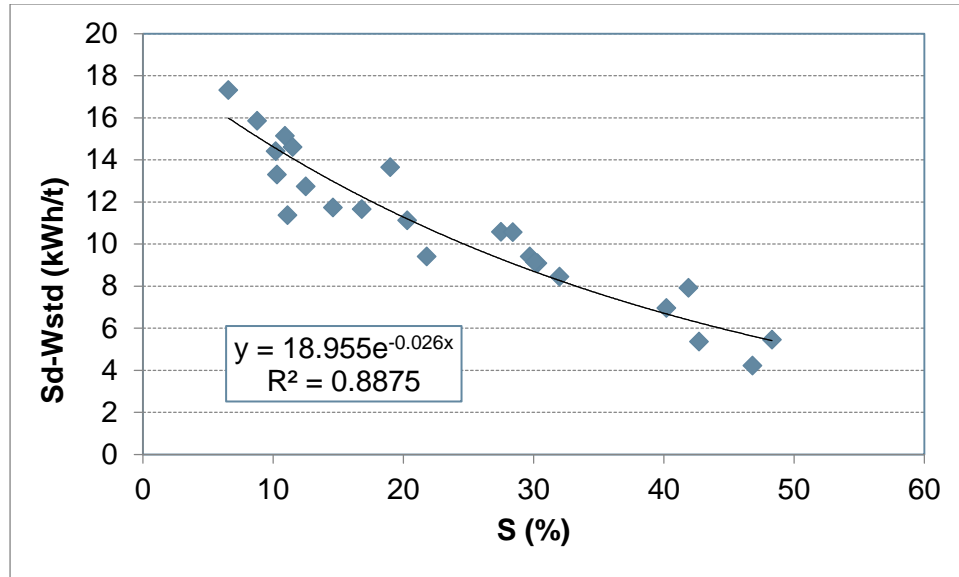

Figure 13-15: Relation between SAGDesign SAG work index and sulphur grade

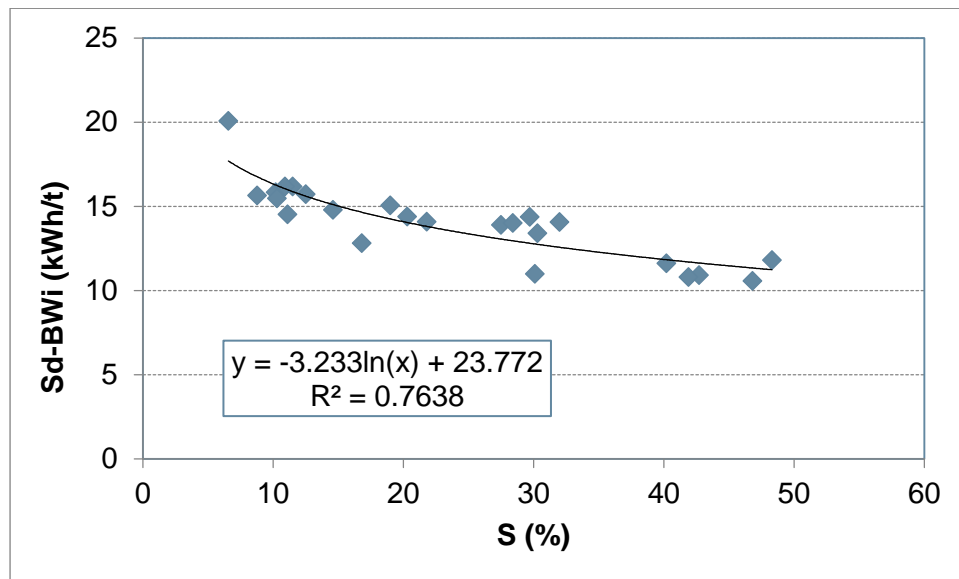

Figure 13-16: Relation between SAGDesign ball mill work index and sulphur grade



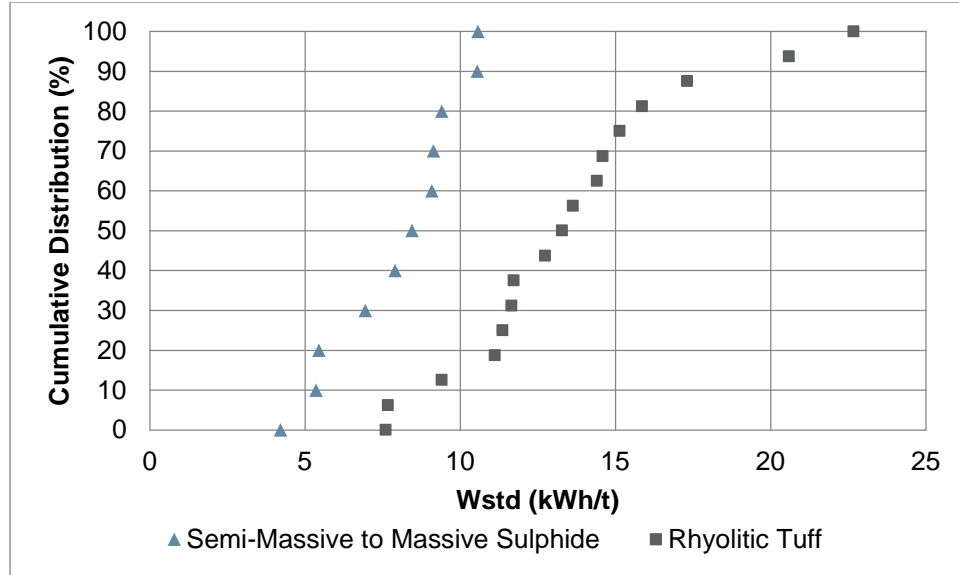

Figure 13-17: SAGDesign SAG grindability index distribution for PEA study and FS composites

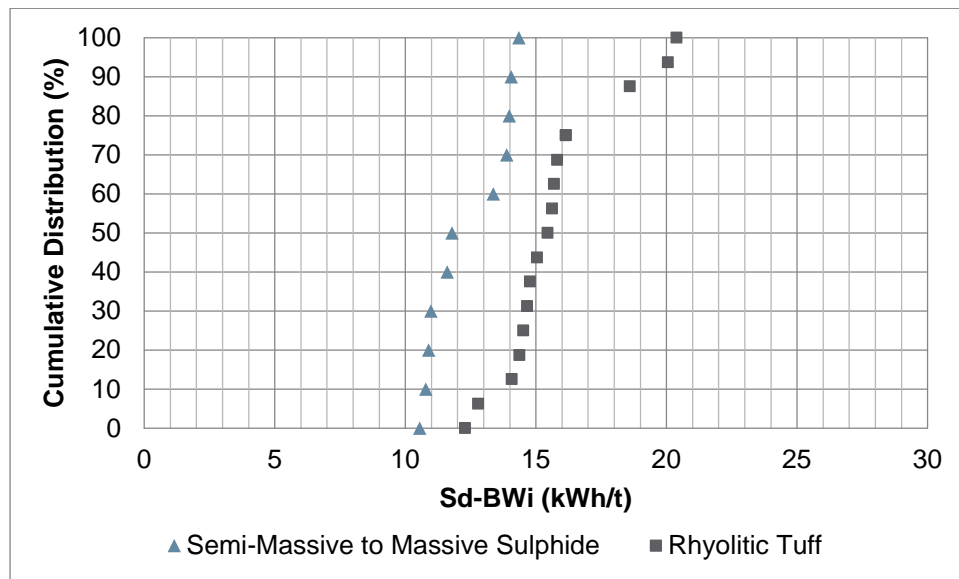

Figure 13-18: Starkey ball mill pinion energy distribution for PEA and FS composites

The marked inverse correlation displayed by all the grinding work indices against sulphur content allows consideration of this parameter as the primary selection criteria of the design ore definition, for sizing of the grinding mills. Therefore, instead of having to rely on whether the population of the selected samples used to generate a limited set of grindability indices is representative of the weighing of the rock types, the sulphur distribution from the complete block model can be considered to select the appropriate design point. Since the hardness is inversely correlated to sulphur, a 20<sup>th</sup> percentile of the sulphur content distribution is used instead of a standard 80<sup>th</sup> percentile of the hardness measurement profile.

Figure 13-19 and Figure 13-20 present the result of the sulphur distribution analysis carried out from the proposed mine plan, as provided by InnovExplo in February 2017. The distribution is based on cumulative tonnages over the mining periods represented on a stope-by-stope basis. It excludes development ore tonnage, representing 3.7% of total reserves, as no sulphur content was assigned to this material.

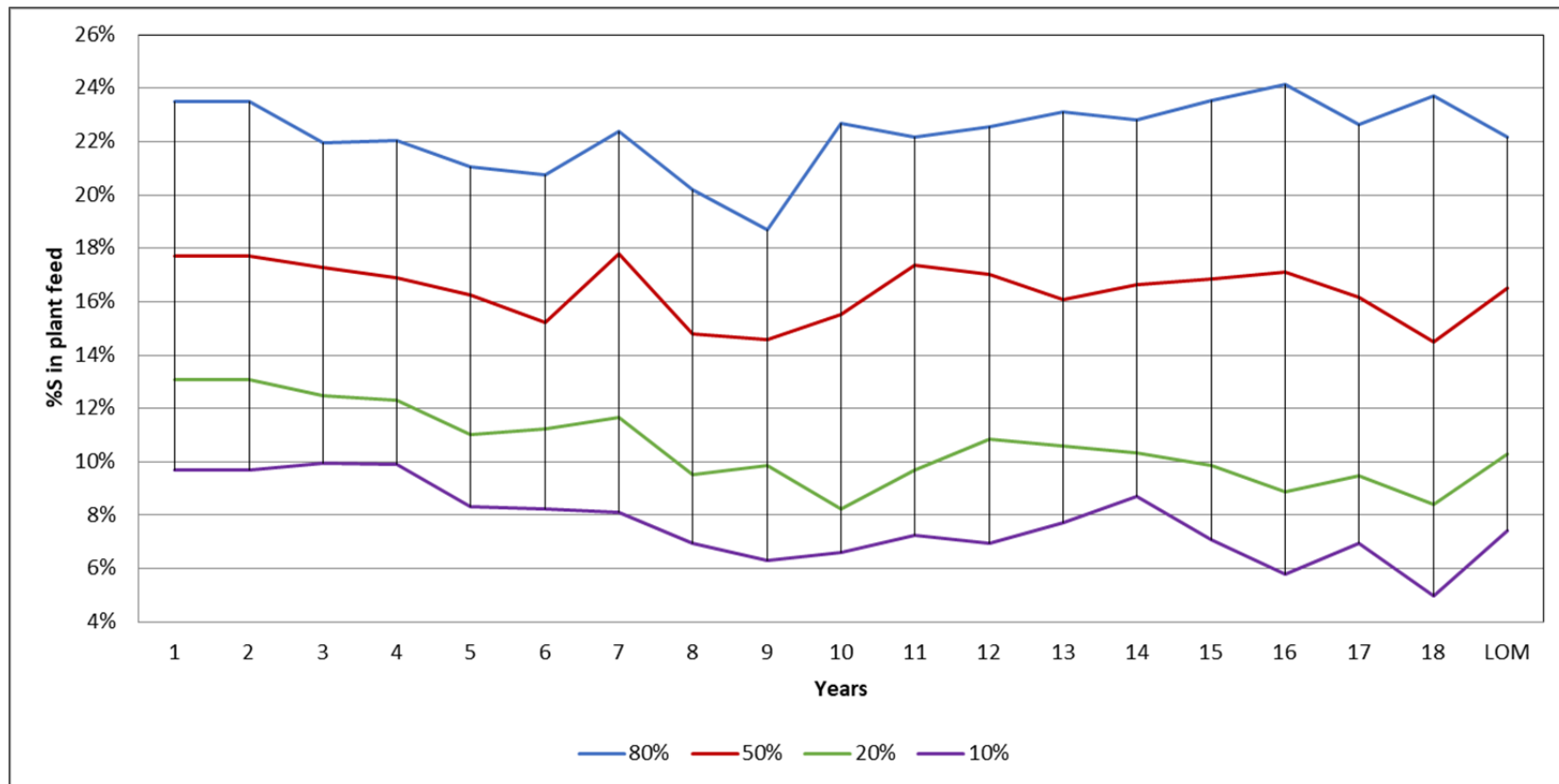

Figure 13-19: Selected percentiles of sulphur distribution from mined stope tonnage per period

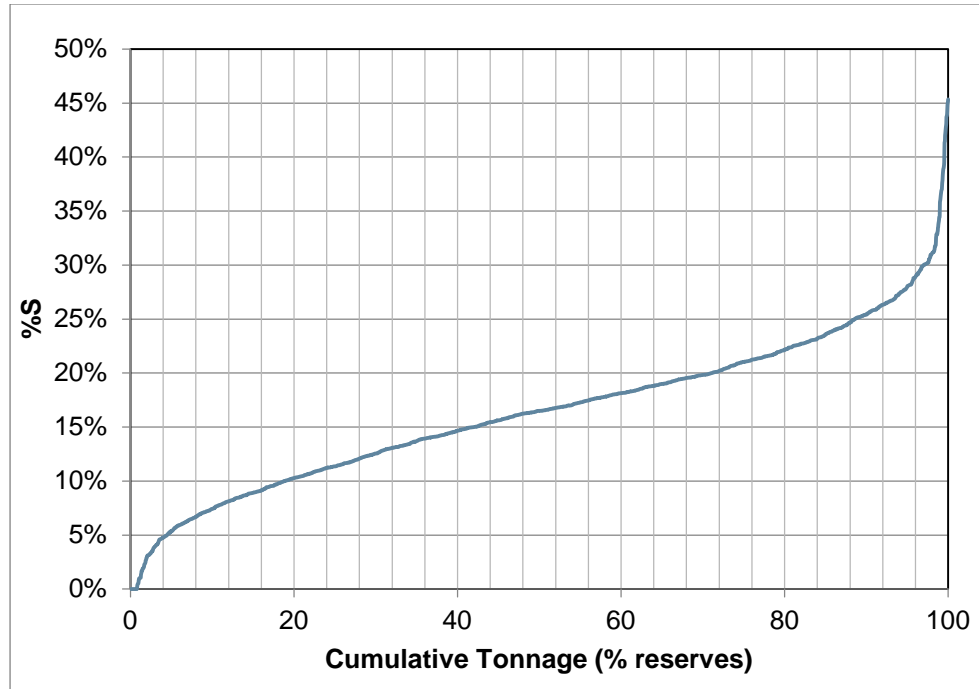

Figure 13-20: Cumulative sulphur distribution from mined stope tonnage over LOM

Per Figure 13-20 and considering the 20<sup>th</sup> percentile of the yearly distributions, a value of 10% S is selected as relevant to cover the higher hardness expected from most of the mining years while the early years would provide somewhat softer material. This sulphur level is also aligned with the LOM 20<sup>th</sup> percentile sulphur content of 10.3%. Applying these values to the regression equations shown in Figure 13-11 to Figure 13-15, the design parameters presented in Table 13-17 are extracted for sizing of the grinding mills.

Table 13-17: Grindability indices applicable to design and average ore

Parameter	Units	Design Ore	Average Ore
Sulphur content	%S	10	16.46
Bond rod mill work index (RWi)	kWh/t	18.1	16.6
Bond ball mill work index (BWi)	kWh/t	16.2	15.2
SG	t/m <sup>3</sup>	3.07	3.32
Ai	g	0.61	0.51
SAGDesign SAG Wstd	kWh/t	14.6	12.4
SAGDesign ball mill Wi	kWh/t	16.3	14.7

## 13.4 Flotation Testwork

At the PEA level, flotation testwork undertaken included a number of separation processes including:

- Bulk sulphide flotation;
- Bulk sulphide flotation followed by copper flotation from the bulk concentrate;
- Differential flotation of copper/pyrite and copper/zinc/pyrite.

In total, 36 flotation tests were conducted, including:

- Twelve (12) rougher kinetics tests for bulk sulphide flotation or copper flotation (M1, M2, M3 and M4 composites);
- Five (5) rougher kinetics test for differential copper, zinc and pyrite flotation (M5, M6, M7, M8 and M9 composites);
- Seventeen (17) cleaning tests for differential copper, zinc and pyrite flotation (M1/M2 blend, M3, M4, and MCB composites);
- Two (2) locked-cycle tests for differential copper, zinc and pyrite flotation (MCA, MCB).

At the end, a flotation flowsheet was developed including a copper sulphide rougher and cleaner flotation step, followed by a zinc sulphide rougher and cleaner flotation circuit and a final rougher pyrite flotation stage.

Phase 1 of the FS flotation test program aims to confirm the flowsheet. A first series of tests was undertaken using the SS2021, SS2022 and SS2025 samples to determine whether any further optimization was possible. The additional flotation tests included:

- Rougher kinetic flotation tests (F1, F2, F3) to determine the flotation kinetic;
- Rougher kinetic flotation tests (F3-F5) to evaluate the use of H<sub>2</sub>SO<sub>4</sub> vs CO<sub>2</sub> vs no pH adjustment in pyrite flotation;
- Cleaner tests to evaluate the effect of grind size (P<sub>80</sub> ranges of 50-60 µm, 60-70 µm and 80-90 µm);
- Flash flotation to evaluate the potential for recovering additional gold (F13).

Finally, locked-cycle tests were performed in duplicate on each of the three samples to confirm the PEA flowsheet.

Another series of tests using samples H5-P2-C1 to H5-P2-C6 was done to validate the flowsheet performance at various head grade. The intent of this series of tests, corresponding to Phase 2 of the test program, was also to determine the variation of numerous parameters with the ore grade, like the collectors addition rates.

Phase 3 was then commissioned to test six additional variability samples (H5-P3-C1 to H5-P3-C6). The intent of this phase was to apply the same testwork approach as optimized during Phase 2, to confirm the influence of reagent addition rates in relation with the variable copper, zinc and sulphur feed grades.

### 13.4.1 Bulk Sulphide Flotation

Bulk sulphide kinetic flotation tests were conducted on composites M1 to M4. Poor results were observed in terms of upgrading potential and in subsequent cleaning tests. No additional work was pursued based on this approach.

### 13.4.2 Selective Flotation

#### 13.4.2.1 PEA Phase

##### Composites M1 to M4

A series of differential flotation tests was undertaken on composite M3 and on a blended composite of M1 and M2. Initially, tests consisted of copper flotation followed by pyrite flotation. An intermediate zinc flotation step was introduced for composite M3 since the contained zinc warranted such an approach.

The copper flotation testwork conducted included the investigation of the following parameters:

- Primary grinds of 85 µm vs 65 µm, as well as a primary grind of 85 µm with regrind to approximately 45 µm ahead of copper cleaning;
- pH in copper rougher (10-11) adjusted with lime;
- Use of dithiophosphate (R238) vs sodium isopropyl xanthate (“SIPX”) vs selective thionocarbamate collector (F1234) in copper circuit.

Based on the preliminary results obtained from a limited number of tests, the testwork indicated that a primary grind of 60-65 µm, and the addition of SIPX as collector, produced improved copper recovery and upgrading capability. Following this work, the zinc circuit demonstrated good results in terms of recovery and grade in most tests operating at a pH of 11-11.5, with copper sulphate (“CuSO<sub>4</sub>”) addition for zinc activation and the use of SIPX as the collector. The pyrite flotation step operated at pH 8.5 after sulphuric acid addition, using PAX as collector to recover the majority of the sulphides remaining following copper and zinc flotation. The frother used in all three flotation stages was MIBC.

The sample selection was made prior to the production of the March 2016 MRE, dated January 8, 2016. Therefore, at the time it was unknown that the average sulphur content of the resource estimate was 18.9% (vs approximately 16% for M1/M2 blend and 30% for M3).

### Composites M5 to M9

Using the optimal conditions determined for the M1/M2 and M3 composites, a series of kinetic flotation tests was undertaken for the M5 to M9 composites for the copper, zinc and pyrite flotation stages. Copper recoveries of 73% to 89% were achieved, with a general trend towards increasing recovery by increasing copper head grade. It was noted that inconsistent zinc recoveries during zinc flotation were due to insufficient dosing of CuSO<sub>4</sub>. Once dosing calculations were corrected, recoveries of 86% or greater were obtained.

A wide variation in the amount of gold recovered to the copper concentrates was observed in the five composites tested, from 31% to 70%. This was attributed to the gold mineralogical variability between composites.

### Locked Cycle Flotation Tests

Locked-cycle flotation tests (“LCT1” and “LCT2”) were conducted on the MCA and MCB blended composites respectively. LCT1 consisted of six 2 kg charge cycles, while the LCT2 tests processed 15 cycles of 4 kg each. The products of the latter test were subsequently used for optimization and bulk leaching tests of both the pyrite concentrate and pyrite flotation tailings, followed by cyanide destruction tests, as well as thickening and rheology tests.

A summary of the locked-cycle test results for composites MCA and MCB is presented in Table 13-18.

Table 13-18: Locked-cycle test results for composites MCA and MCB

Comp.	Product	Mass (%)	Assay (g/t or %)					Distribution (%)				
			Cu	Zn	Au	Ag	S	Cu	Zn	Au	Ag	S
MCA (LCT1)	Head	100	0.25	0.78	1.96	21.1	24.8	100	100	100	100	100
	Cu 3 <sup>rd</sup> Cl conc.	1.0	21.2	4.51	117	796	37.6	85.7	5.9	61.0	38.5	1.5
	Zn 2 <sup>nd</sup> Cl conc.	1.1	0.26	48.8	5.09	127	33.0	1.1	68.7	2.9	6.6	1.5
	Py Cl conc.	50.4	0.06	0.38	1.26	20.6	47.5	11.0	24.5	32.4	49.1	96.4
	Py tail	47.5	0.01	0.01	0.15	2.6	0.30	2.2	0.9	3.7	5.8	0.6
MCB (LCT2)	Head	100	0.20	0.96	1.64	14.7	24.5	100	100	100	100	100
	Cu 3 <sup>rd</sup> Cl conc.	0.8	18.7	2.86	56.8	315	41.4	79.4	2.5	29.4	18.2	1.4
	Zn 2 <sup>nd</sup> Cl conc.	1.9	0.31	46.9	4.06	120	37.0	2.9	93.5	4.7	15.5	2.9
	Py Cl conc.	47.2	0.06	0.05	2.07	18.4	49.5	13.0	2.5	59.6	59.1	95.4
	Py tail	50.1	0.02	0.03	0.20	2.08	0.15	4.6	1.5	6.2	7.1	0.3

In both locked-cycle tests, good copper recoveries were achieved, with 85.7% and 79.4% for LCT1 and LCT2 respectively. Copper concentrate grades of 21.2% Cu and 18.7% Cu were also within the targeted range for this circuit.



Zinc recovery to the LCT2 Zn 2<sup>nd</sup> cleaner concentrate was 93.5%, however, the grade was below the target, at 46.9% Zn. In LCT1, only 68.7% of the zinc was recovered to the Zn 2<sup>nd</sup> cleaner, with a grade of 48.8% Zn. As was previously observed in the M5-M9 kinetic tests, the low zinc recovery in LCT1 may have been due to a lower than required CuSO<sub>4</sub> addition. As the targeted range for the concentrate grade is 48-55% Zn, additional work to improve the consistency of the results is required.

The mass recovery to the pyrite rougher concentrate remained consistent relative to previous results, with 50.4% and 47.2% obtained in tests LCT1 and LCT2 respectively. The amount of gold reporting to the pyrite concentrate varied though, with 32.4% in LCT1 vs 59.6% in LCT2. Silver recovery to the pyrite concentrate was more stable with 49.1% and 59.1% reporting to the LCT1 and LCT2 pyrite concentrates, respectively.

The only test with sulphur content in line with the range expected for the yearly averages of the mine life, as per the subsequent PEA data provided, involved the M1/M2 blend (approximately 16% S). All other composites tested for pyrite flotation had higher sulphur content than the average of the resources, calculated then as 18.9% S.

#### 13.4.2.2 FS Testwork Phases

For the FS testwork, LCT trials were performed in Phase 1 with the composites SS2021, SS2022 and SS2025, as reported in Table 13-19. Six new composites (H5-P2-C1 to H5-P2-C6) were prepared for Phase 2, with the results shown in Table 13-20, and six more (H5-P3-C1 to H5-P3-C6) for Phase 3, per Table 13-21. Whereas Phase 1 was meant to optimize reagent regime, pH and addition points, Phase 2 and Phase 3 were mostly carried out as variability testwork implicating material from different location within the deposit and with varying feed grades.

It was soon recognize that adjustments to the collector dosages and copper sulphate were required in order to optimize the results, in line with the feed grades of copper (for SIPX and R208), zinc (for copper sulphate and SIPX) and sulphur (for PAX). Higher-grading samples delivered final concentrate grades after only two stages of flotation along with the three typically used.

Table 13-19: Locked-cycle test results for composites SS2021 to SS2025 – Phase 1

Comp.	Product	Mass (%)	Assay (g/t or %)					Distribution (%)				
			Cu	Zn	Au	Ag	S	Cu	Zn	Au	Ag	S
LCT-1	Cu 3 <sup>rd</sup> CI Conc.	1.1	17.3	2.56	53	427	38.4	86.2	3.0	40.9	35.2	1.6
	Zn 3 <sup>rd</sup> CI Conc.	1.6	0.34	54.7	3.4	96	34.4	2.4	91.9	3.7	11.3	2.0
	Py Ro Conc.	54.7	0.04	0.06	1.4	12	47.5	9.3	3.8	53.0	47.2	96.0
	Py Ro Tail	42.6	0.01	0.03	0.1	2.0	0.3	2.0	1.4	2.4	6.3	0.4
	Head (calc.)	100	0.22	0.95	1.4	14	27.1	100	100	100	100	100
LCT-2	Cu 3 <sup>rd</sup> CI Conc.	1.2	16.1	2.51	55	404	39.1	87.5	3.3	45.0	34.4	1.7
	Zn 3 <sup>rd</sup> CI Conc.	1.6	0.28	52.9	2.2	86	35.2	2.0	92.0	2.5	9.8	2.1
	Py Ro Conc.	55.4	0.03	0.06	1.3	12	46.9	7.8	3.6	50.2	48.7	95.8
	Py Ro Tail	41.8	0.01	0.02	0.1	2.4	0.2	2.7	1.1	2.3	7.0	0.4
	Head (calc.)	100	0.22	0.92	1.5	14	27.1	100	100	100	100	100
LCT-3	Cu 3 <sup>rd</sup> CI Conc.	0.8	15.6	6.80	121	677	35.0	83.7	5.4	49.1	37.7	2.1
	Zn 3 <sup>rd</sup> CI Conc.	1.7	0.39	53.1	5.4	108	33.1	4.5	90.4	4.7	12.9	4.3
	Py Ro Conc.	30.0	0.04	0.07	2.4	19	41.0	7.3	2.0	36.8	39.4	93.2
	Py Ro Tail	67.5	0.01	0.03	0.3	2.2	0.1	4.5	2.2	9.4	10.1	0.3
	Head (calc.)	100	0.15	1.01	2.0	14	13.2	100	100	100	100	100
LCT-4	Cu 3 <sup>rd</sup> CI Conc.	0.8	15.3	6.48	119	672	36.9	84.4	5.4	48.8	40.1	2.3
	Zn 3 <sup>rd</sup> CI Conc.	1.7	0.35	53.4	5.1	104	33.6	4.0	90.7	4.3	12.7	4.2
	Py Ro Conc.	31.5	0.03	0.06	2.4	16	39.4	6.6	2.1	37.3	37.9	93.2
	Py Ro Tail	66.0	0.01	0.03	0.3	1.9	0.1	5.0	1.8	9.5	9.3	0.3
	Head (calc.)	100	0.15	0.99	2.0	14	13.3	100	100	100	100	100
LCT-5	Cu 3 <sup>rd</sup> CI Conc.	0.8	18.1	1.79	59	811	34.9	80.9	1.3	36.1	28.7	0.9
	Zn 3 <sup>rd</sup> CI Conc.	1.7	0.41	60.1	2.2	143	32.8	3.9	90.3	2.8	10.8	1.8
	Py Ro Conc.	64.2	0.04	0.13	1.2	19	46.1	13.4	7.2	58.3	53.2	96.7
	Py Ro Tail	33.3	0.01	0.04	0.1	5.0	0.5	1.8	1.3	2.8	7.3	0.5
	Head (calc.)	100	0.18	1.13	1.3	23	30.6	100	100	100	100	100
LCT-6	Cu 3 <sup>rd</sup> CI Conc.	0.8	18.2	1.89	63	816	35.8	79.7	1.4	37.7	30.1	1.0
	Zn 3 <sup>rd</sup> CI Conc.	1.7	0.36	59.2	2.6	148	33.2	3.3	90.6	3.2	11.4	1.9
	Py Ro Conc.	64.8	0.04	0.12	1.2	18	45.6	15.0	6.8	56.4	51.8	96.7
	Py Ro Tail	32.6	0.01	0.04	0.1	4.6	0.5	2.0	1.3	2.7	6.7	0.5
	Head (calc.)	100	0.19	1.13	1.4	22	30.6	100	100	100	100	100

Table 13-20: Locked-cycle test results for composites H5-P2-C1 to H5-P2-C6 – Phase 2

Comp./ Test	Product	Mass (%)	Assay (g/t or %)					Distribution (%)				
			Cu	Zn	Au	Ag	S	Cu	Zn	Au	Ag	S
C1	Cu 3 <sup>rd</sup> CI Conc.	1.0	13.1	3.72	59.0	547	38.8	81.4	5.5	40.6	36.3	2.0
LCT-7	Zn 3 <sup>rd</sup> CI Conc.	1.2	0.33	45.2	4.20	115	33.0	2.7	88.1	3.8	10.0	2.2
	Py Ro Conc.	45.6	0.04	0.06	1.52	14.7	38.6	12.2	4.4	50.1	47.0	95.5
	Py Ro Tail	52.2	0.01	0.02	0.15	1.8	0.11	3.7	2.0	5.5	6.7	0.3
	Head (calc.)	100	0.15	0.64	1.38	14.3	18.4	100	100	100	100	100
C1	Cu 3 <sup>rd</sup> CI Conc.	0.8	15.5	3.62	65.4	658	36.0	77.6	4.3	36.0	32.9	1.5
LCT-16	Zn 3 <sup>rd</sup> CI Conc.	1.1	0.58	53.0	6.08	118.4	33.8	4.0	87.8	4.6	8.2	1.9
	Py Ro Conc.	42.3	0.049	0.080	1.77	18.6	42.6	13.3	5.2	53.1	50.7	96.1
	Py Ro Tail	55.8	0.014	0.030	0.16	2.30	0.15	5.0	2.6	6.3	8.3	0.5
	Head (calc.)	100	0.16	0.65	1.41	15.5	18.8	100	100	100	100	100
C2	Cu 3 <sup>rd</sup> CI Conc.	0.9	11.8	4.03	65.0	684	35.8	74.7	2.5	53.7	28.5	1.2
LCT 10	Zn 3 <sup>rd</sup> CI Conc.	2.4	0.29	53.6	2.53	115	33.8	5.1	92.0	5.8	13.4	3.1
	Py Ro Conc.	59.2	0.04	0.11	0.68	18.5	41.7	17.3	4.6	38.3	52.7	95.3
	Py Ro Tail	37.5	0.01	0.04	0.06	3.0	0.27	2.9	1.0	2.1	5.4	0.4
	Head (calc.)	100	0.14	1.41	1.05	20.8	25.9	100	100	100	100	100
C3	Cu 3 <sup>rd</sup> CI Conc.	1.2	17.5	4.36	30.2	400	36.9	83.5	4.5	41.3	32.0	1.3
LCT-8	Zn 3 <sup>rd</sup> CI Conc.	1.7	0.35	57.4	1.45	79.1	32.8	2.3	81.9	2.7	8.6	1.6
	Py Ro Conc.	73.5	0.05	0.20	0.65	11.5	46.8	13.0	12.7	53.2	54.7	96.8
	Py Ro Tail	23.6	0.01	0.05	0.10	3.0	0.54	1.2	0.9	2.7	4.6	0.4
	Head (calc.)	100	0.26	1.19	0.90	15.5	35.6	100	100	100	100	100
C3	Cu 3 <sup>rd</sup> CI Conc.	0.9	23.8	3.78	35.8	478	35.6	79.1	3.0	35.2	26.8	0.9
LCT 13	Zn 3 <sup>rd</sup> CI Conc.	1.5	0.48	59.7	1.44	80.3	33.2	2.9	85.3	2.6	8.2	1.5
	Py Ro Conc.	66.8	0.062	0.17	0.75	13.3	49.1	16.2	10.3	57.7	58.7	97.0
	Py Ro Tail	30.8	0.015	0.051	0.13	3.47	0.59	1.8	1.5	4.5	6.3	0.5
	Head (calc.)	100	0.26	1.09	0.87	15.7	33.8	100	100	100	100	100
C4	Cu 3 <sup>rd</sup> CI Conc.	0.7	12.4	7.24	69.3	466	36.4	85.1	12.8	41.4	35.9	2.4
LCT 11	Zn 3 <sup>rd</sup> CI Conc.	0.8	0.39	41.9	7.18	103	32.0	2.9	81.7	4.7	8.8	2.3
	Py Ro Conc.	37.2	0.02	0.04	1.56	11.2	29.0	6.4	3.3	46.6	42.9	94.9
	Py Ro Tail	61.3	0.01	0.01	0.15	2.0	0.07	5.5	2.1	7.3	12.5	0.4
	Head (calc.)	100	0.11	0.42	1.24	9.7	11.4	100	100	100	100	100
C5	Cu 3 <sup>rd</sup> CI Conc.	1.3	12.4	2.66	61.9	290	39.2	81.7	3.7	52.4	32.8	2.5
LCT-9	Zn 3 <sup>rd</sup> CI Conc.	1.9	0.24	43.0	4.81	78.8	26.2	2.3	88.0	6.0	13.0	2.4
	Py Ro Conc.	46.1	0.05	0.10	1.17	11.5	41.4	12.8	5.3	35.7	46.8	94.7
	Py Ro Tail	50.7	0.01	0.06	0.18	1.6	0.15	3.3	3.1	5.9	7.4	0.4
	Head (calc.)	100	0.19	0.91	1.51	11.3	20.1	100	100	100	100	100

Comp./ Test	Product	Mass (%)	Assay (g/t or %)					Distribution (%)				
			Cu	Zn	Au	Ag	S	Cu	Zn	Au	Ag	S
C5	Cu 3 <sup>rd</sup> CI Conc	0.9	16.6	2.96	88.0	371	36.3	79.2	3.1	51.1	34.7	1.7
LCT-14	Zn 3 <sup>rd</sup> CI Conc	1.7	0.46	47.3	7.23	93.3	28.6	3.9	87.2	7.5	15.6	2.4
	Py Ro Conc	41.8	0.063	0.14	1.33	10.0	44.6	13.6	6.4	34.7	42.0	95.4
	Py Ro Tail	55.7	0.012	0.055	0.19	1.38	0.15	3.3	3.4	6.7	7.7	0.4
	Head (calc.)	100	0.20	0.90	1.60	10.0	19.5	100	100	100	100	100
C6	Cu 3 <sup>rd</sup> CI Conc	0.9	13.7	7.12	76.1	503	36.9	84.3	8.7	46.3	37.8	2.3
LCT-12	Zn 3 <sup>rd</sup> CI Conc	1.5	0.28	42.6	3.93	77.4	34.1	2.9	85.8	4.0	9.6	3.6
	Py Ro Conc	37.1	0.04	0.06	1.75	13.9	36.3	8.8	3.0	43.4	42.6	93.6
	Py Ro Tail	60.4	0.01	0.03	0.16	<2	0.12	4.1	2.5	6.3	10.0	0.5
	Head (calc.)	100	0.15	0.75	1.50	12.1	14.4	100	100	100	100	100
C6	Cu 3 <sup>rd</sup> CI Conc	0.8	16.0	7.49	81.0	514	35.5	82.3	7.9	51.7	36.5	1.9
LCT-15	Zn 3 <sup>rd</sup> CI Conc	1.4	0.46	47.0	5.73	85.0	35.1	4.1	85.8	6.3	10.4	3.2
	Py Ro Conc	32.9	0.042	0.083	2.14	15.9	43.1	8.9	3.6	25.4	46.1	94.4
	Py Ro Tail	64.9	0.011	0.032	0.16	1.2	0.12	4.7	2.7	16.6	7.0	0.5
	Head (calc.)	100	0.16	0.76	1.53	11.3	15.0	100	100	100	100	100

Table 13-21: Locked-cycle test results for composites H5-P2-C1 to H5-P2-C6 – Phase 3

Comp/T est.	Product	Mass (%)	Assay (g/t or %)					Distribution (%)				
			Cu	Zn	Au	Ag	S	Cu	Zn	Au	Ag	S
C1	Cu 3 <sup>rd</sup> CI Conc.	1.3	14.2	2.66	33.9	376	43.1	88.9	28.8	35.9	41.6	3.0
LCT-19	Zn 3 <sup>rd</sup> CI Conc.	0.3	0.81	27.2	nss	nss	43.0	1.0	56.6	nss	nss	0.6
	Py Ro Conc.	44.1	0.036	0.028	1.75	13.9	42.6	7.2	9.9	60.3	50.2	96.2
	Py Ro Tail	54.3	0.012	0.011	0.090	<1.83	0.073	2.9	4.7	3.8	8.2	0.2
	Head (calc.)	100	0.22	0.13	1.28	12.2	19.5	100	100	100	100	100
C2	Cu 3 <sup>rd</sup> CI Conc.	0.8	14.8	3.87	82.0	534	41.7	74.5	3.5	61.2	26.3	0.8
LCT-22	Zn 3 <sup>rd</sup> CI Conc.	1.2	0.35	56.4	1.82	79.0	35.1	2.8	79.6	2.1	6.1	1.1
	Py Ro Conc.	82.3	0.039	0.17	0.43	11.9	46.9	21.4	16.4	35.1	64.0	97.9
	Py Ro Tail	15.8	0.013	0.027	0.10	3.50	0.59	1.3	0.5	1.5	3.6	0.2
	Head (calc.)	100	0.15	0.84	1.01	15.3	39.4	100	100	100	100	100
C3	Cu 2 <sup>nd</sup> CI Conc.	1.2	20.5	2.85	62.4	757	39.3	82.8	3.9	51.2	29.7	1.3
LCT-20	Zn 2 <sup>nd</sup> CI Conc.	1.5	0.52	46.6	2.58	102	36.0	2.7	81.4	2.7	5.2	1.5
	Py Ro Conc.	74.9	0.054	0.16	0.88	25.5	47.2	13.5	14.0	45.2	62.6	97.0
	Py Ro Tail	22.4	0.013	0.030	0.055	3.47	0.37	1.0	0.8	0.8	2.5	0.2
	Head (calc.)	100	0.30	0.88	1.46	30.5	36.4	100	100	100	100	100
C4	Cu 3 <sup>rd</sup> CI Conc.	0.7	15.7	4.61	90.6	455	38.1	84.9	8.2	38.9	38.5	2.2
LCT-21	Zn 2 <sup>nd</sup> CI Conc.	0.9	0.15	35.8	3.74	49.4	40.1	1.1	82.1	2.1	5.4	3.1
	Py Ro Conc.	30.2	0.036	0.044	2.86	14.3	37.6	8.2	3.3	52.3	51.4	94.2
	Py Ro Tail	68.2	0.011	0.037	0.16	<0.57	0.085	5.8	6.4	6.7	4.7	0.5
	Head (calc.)	100	0.13	0.40	1.65	8.39	12.1	100	100	100	100	100
C5	Cu 3 <sup>rd</sup> CI Conc.	0.5	15.4	5.29	121	1632	39.2	62.5	2.5	37.2	30.6	0.6
LCT-23	Zn 2 <sup>nd</sup> CI Conc.	1.9	0.51	51.9	5.62	154	33.3	7.4	86.8	6.1	10.3	1.9
	Py Ro Conc.	72.6	0.050	0.16	1.30	21.6	44.4	28.2	10.1	54.8	55.7	97.3
	Py Ro Tail	24.9	0.010	0.029	0.13	3.88	0.24	1.9	0.6	1.9	3.4	0.2
	Head (calc.)	100	0.13	1.13	1.73	28.2	33.2	100	100	100	100	100
C6	Cu 2 <sup>nd</sup> CI Conc.	0.3	18.8	5.57	223	2670	37.5	51.2	0.8	57.3	72.6	0.3
LCT-24	Zn 2 <sup>nd</sup> CI Conc.	3.2	0.48	58.7	1.17	102.7	33.4	12.7	83.9	3.0	27.4	2.6
	Py Ro Conc.	77.7	0.052	0.43	0.62	0.0	51.2	34.3	14.9	38.6	0.0	96.7
	Py Ro Tail	18.8	0.011	0.046	0.075	<0	0.89	1.8	0.4	1.1	0.0	0.4
	Head (calc.)	100	0.12	2.22	1.25	11.9	41.2	100	100	100	100	100

### 13.4.3 Metallurgical Projections for the Flotation Circuits

The influence of the copper, zinc and pyrite head grades on their eventual recovery to their respective concentrates, along with the various relevant test results achieved, are presented in Figure 13-21 to Figure 13-39. The relationships displayed on these figures have been used to derive the projected metallurgical performance of the flotation circuits.

Some specific test data points are excluded from the analysis to derive the displayed relationships used for projection purposes. Excluded points were, in particular, either associated with a coarser primary grind than the adopted target, for the inclusion of a regrinding step in the (copper) cleaning circuit, for testing of alternate collectors or depressants, or for having been labelled as outliers for their test conditions which were later optimized. These may reflect different collector addition rates, as the dosages were being adjusted to the various head grades encountered.

With many more data points generated from rougher flotation tests than from the LCT, the more robust correlations were typically derived from roughing testwork data. The trend lines displayed by the data tying feed grades to recovery projections were typically fitted against a regression equation of the standard format, for these type of metallurgical relationships, where projected recovery is derived from the expression,  $Recovery = A * (1 - e^{-b*[feed\ grade]})$ , where A and b are the two regression parameters to be fitted to the data set through a normalized least-square approach.

Projections of the cleaning circuit performance for copper and zinc, both in terms of these circuits partial recoveries and upgrading capability, are based on LCT trends or averages derived from series of tests.

Final concentrate grade targets of 15-18% Cu for the copper concentrate and 50-52% Zn for the zinc concentrate were used as these are sufficient to provide saleable products and maximize deportment of the economic metals into the respective products. Where additional cleaning stages implemented in the testwork yielded grades above these ranges, the results of a previous cleaning stage displaying a more suitable lower grade, when available, was substituted to the final stage's numbers.

### 13.4.3.1 Copper Rougher Performance Projections

#### Copper Recovery to Copper Rougher Concentrate

The best fit seen from the data set links the expected copper recovery to the copper rougher stage with the copper feed grade, as shown in Figure 13-21. The trend line in the figure is mathematically represented by Equation 13-1:

$$\text{Cu recovery to rougher concentrate} = 89.9 * (1 - e^{-16.6 * [\% \text{Cu in feed}]}) \quad [\text{Equation 13-1}]$$

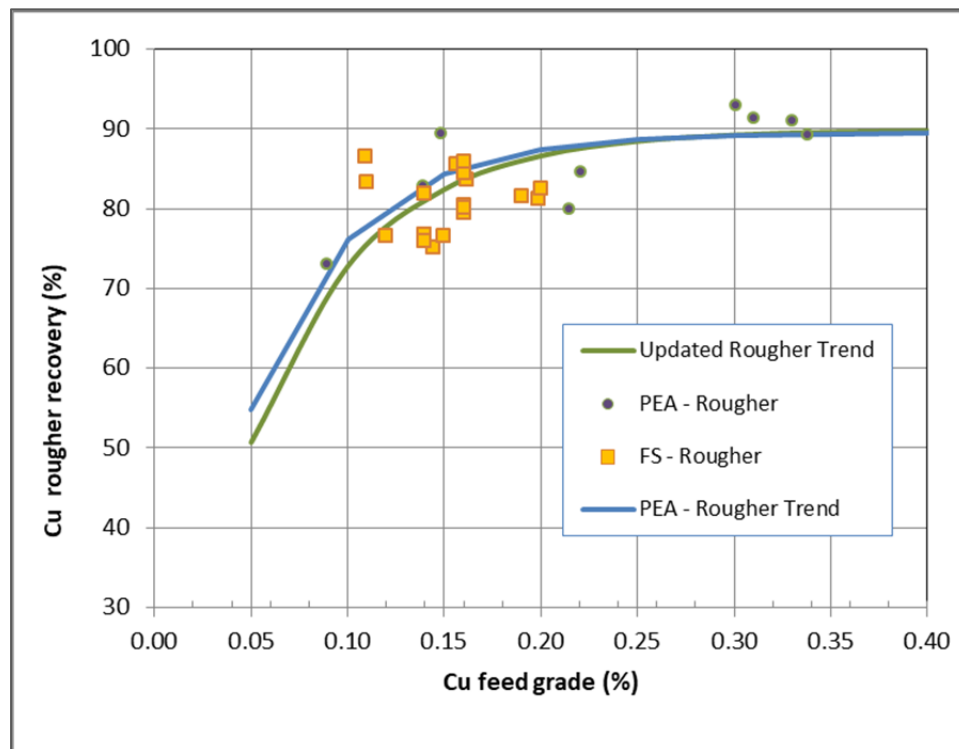

Figure 13-21: Cu recovery to rougher concentrate vs Cu feed grade

Per Figure 13-21, the trend derived from the PEA testwork was above the one obtained by giving also consideration to the FS testwork data once the feed grade is below 0.25% Cu. This reflects the incremental availability of data points in the 0.12-0.25% Cu range brought by the FS.



### Weight Recovery to Copper Rougher Concentrate

The data set indicates that the expected mass pull, e.g. weight recovery, to the copper rougher stage is not linked strongly with any parameter. Figure 13-21 displays the best relationship that could be unearthed from the data analysis. The trend line in the figure is mathematically represented by Equation 13-2:

$$\text{Mass recovery to rougher concentrate} = 1.8752 + 7.5054 * [\%Cu \text{ in feed}] \quad [\text{Equation 13-2}]$$

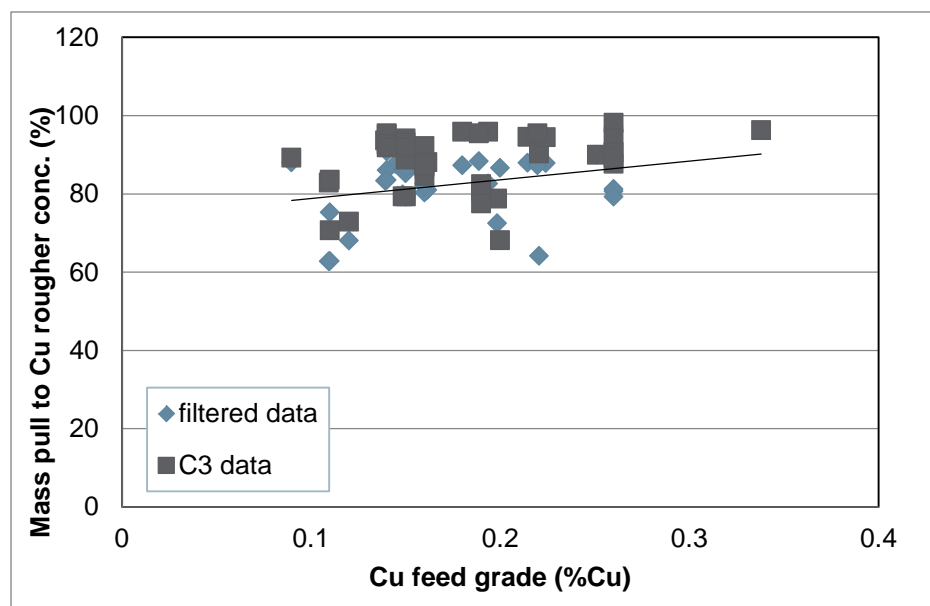

Figure 13-22: Weight recovery to Cu rougher concentrate vs Cu feed grade

The data presented in Figure 13-22 omits tests at a finer primary grind target, with alternate collectors or depressants, nor some tests for which repeats indicated much improved copper recovery outcomes to the rougher concentrate. The results generated with sample H5-P2-C3 have also been excluded as indicating a lower mass pull than the trend line for all the tests realized.

The high variability encountered in the 0.1-0.2% Cu range is deemed as the result of variable collector dosages implemented in order to improve rougher recovery while enabling an appropriate subsequent upgrading within the cleaning circuit.

### Gold Recovery to Copper Rougher Concentrate

As shown in Figure 13-23, the most valid relationship to evaluate the expected gold recovery to the copper rougher concentrate is with the mass pull to this product. The expression of the regression derived from the data is as per Equation 13-3:

$$\text{Au recovery to Cu rougher concentrate} = 62.4 * (1 - e^{-0.79 * [\text{mass pull to Cu Ro conc.}]}) \quad [\text{Equation 13-3}]$$

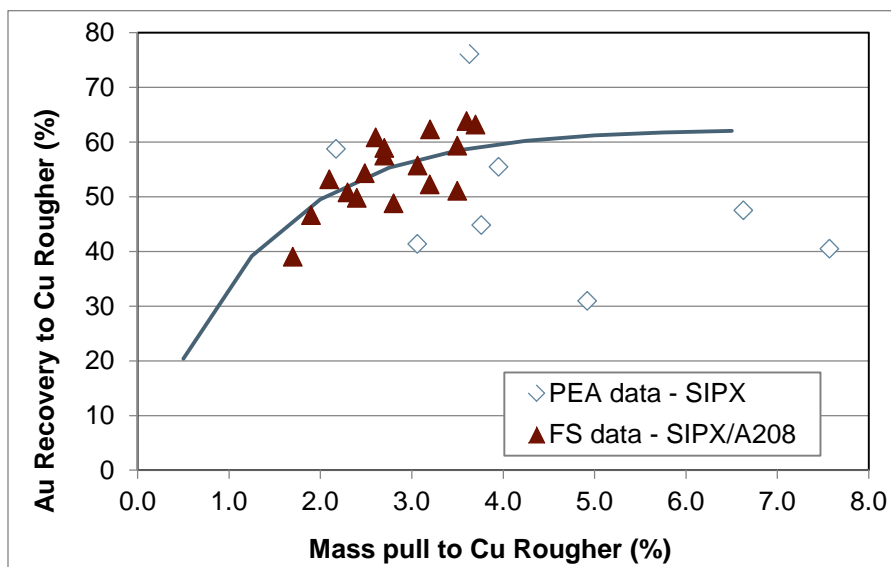

Figure 13-23: Au recovery to Cu rougher concentrate vs mass pull to Cu rougher concentrate

Figure 13-23 data considered for regression excluded the data points obtained during the PEA study stage as the transition from what was then only SIPX as the collector used towards a combination of SIPX and the dithiophosphate Aerofloat R208 is deemed to have enhanced the pulling capability of the system for precious metals.

### Silver Recovery to Copper Rougher Concentrate

Similarly as for gold, Figure 13-24 indicates a strong correlation linking the expected silver recovery to the copper rougher concentrate with the mass pull into this product. The mathematical expression of this relationship is provided by Equation 13-4:

$$\text{g/t Ag of Cu rougher conc.} = 4.3738 * [\text{g/t Au of Cu rougher conc.}] + 39.741 \quad [\text{Equation 13-4}]$$

The above equation can be used once the calculated gold recovery to the copper concentrate, per Equation 13-3, has been assessed and with the copper concentrate weight, calculated from the Equation 13-2 permits to derive the gold grade of the copper rougher concentrate.

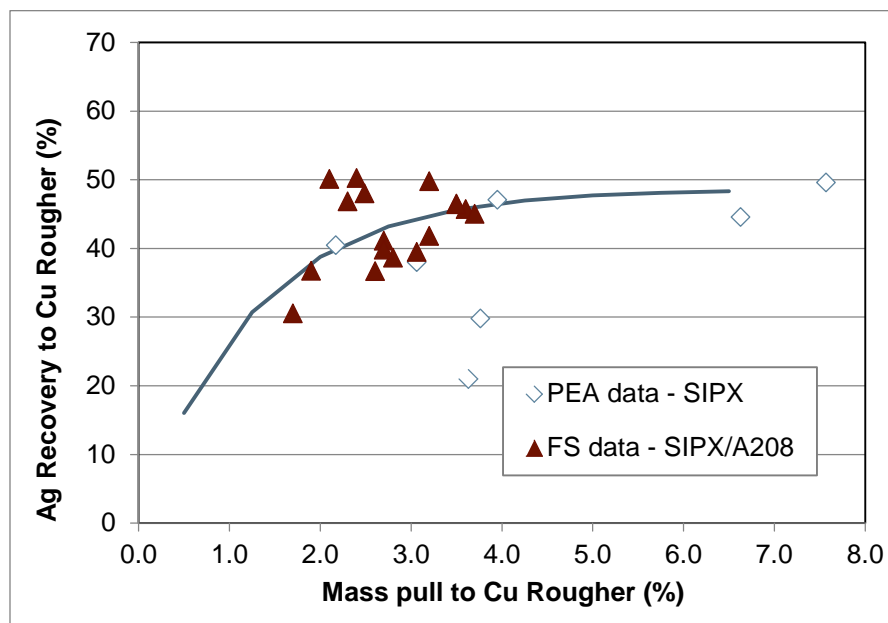

Figure 13-24: Ag recovery to Cu rougher concentrate vs mass pull to Cu rougher concentrate

The same filtering of data, as applied for the case of gold recovery, per Figure 13-24, was employed for silver, considering separately the case of the most recent trials where Aerofloat R208 has been added to SIPX as a precious metal collector.

### 13.4.3.2 Copper Cleaner Performance Projections

#### Copper Recovery to Copper Cleaning Circuit and Global Recovery

The filtered testwork data (excluding fine primary grind, regrinding, alternate collectors and depressants and trials that did not achieve a sufficient concentrate grade, in the 14.5-20% Cu range) is indicative of an average stage recovery for copper in the copper cleaning circuit of 93.5%. Since these tests are run as open circuits, recycling of the intermediate tailing products in a LCT arrangement would allow for an increase of this value, as for an equivalent industrial plant configuration. The fixed cleaning circuit value of 95% used for the PEA was thus warranted.

The variability of final concentrate grades achieved between tests increases the spread of the analyzed data. To take advantage of the various LCT, which have been carried out, the analysis made yields an indication of the cleaning circuit recovery through the differential between the global recovery (from LCT tests) and that to the rougher stage (from batch tests).

Both these relationships are tied to the copper feed grade as shown in Figure 13-25, where the curves for the global recovery for LCT and batch tests are compared with the one presented in Figure 13-21 for the rougher recovery.

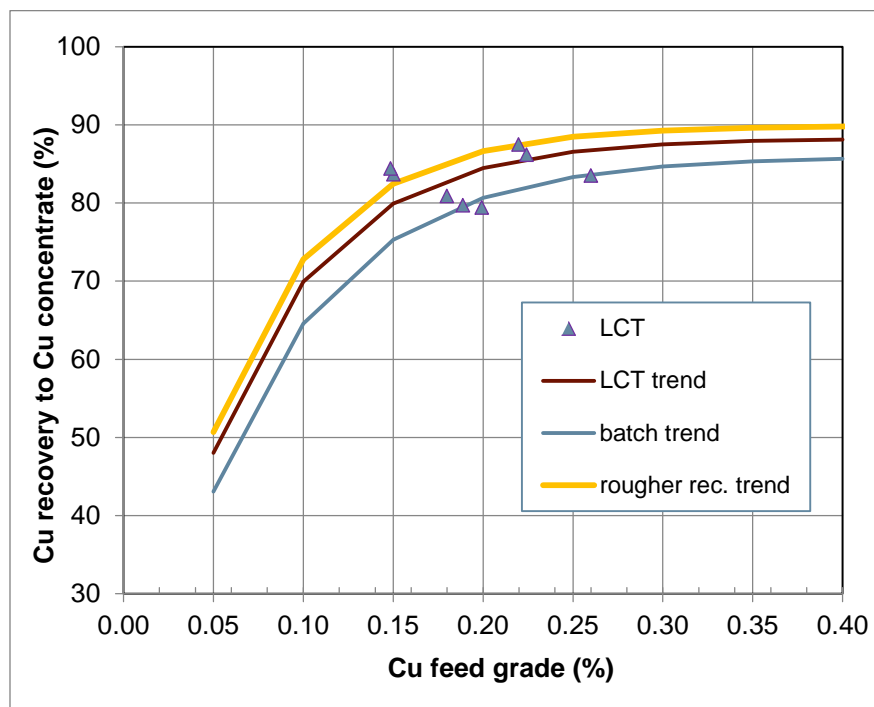

Figure 13-25: Overall and rougher Cu recoveries vs Cu feed grade

The mathematical expression of the relationship considering LCT data yields the global copper recovery to the copper concentrate and is provided by Equation 13-5:

$$\text{Global Cu rec.} = 88.3 * (1 - e^{-15.7 * [\% \text{Cu in feed}]}) \quad [\text{Equation 13-5}]$$

Whereas the trend displayed in Figure 13-25 by the batch cleaner tests data is described by Equation 13-6:

$$\text{Batch global Cu rec.} = 86 * (1 - e^{-13.9 * [\% \text{Cu in feed}]}) \quad [\text{Equation 13-6}]$$

The differential expectations between the batch and LCT trend indicates the additional recovery capability brought by recirculating the intermediate cleaning stage tailings, whereas the drop from rougher data is showing the extent of the losses within either cleaning circuit configuration.

#### Gold Recovery to Copper Cleaning Circuit

The gold recovery to the final copper concentrate is related to the mass pull into the final copper concentrate as per Figure 13-26.

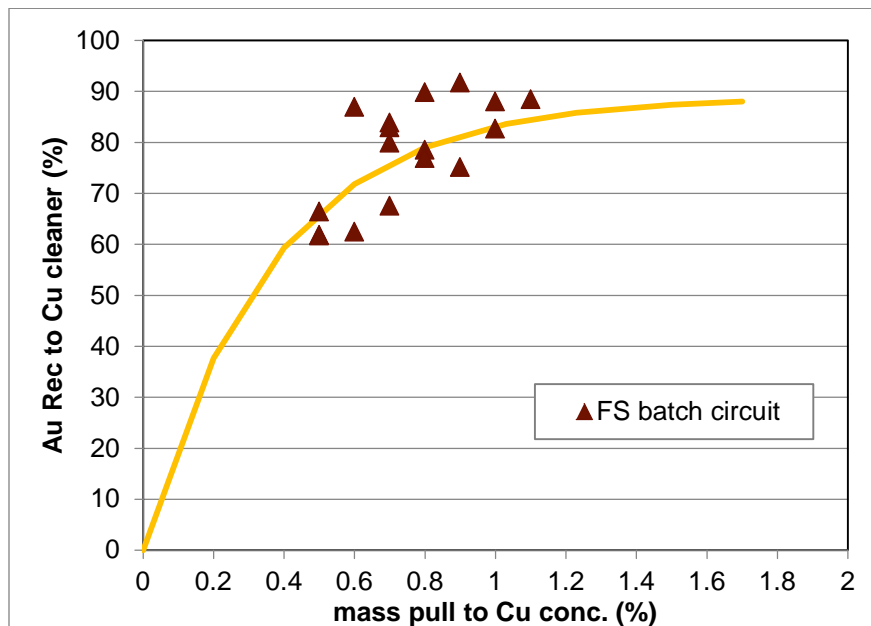

Figure 13-26: Cu cleaning circuit Au recovery vs mass pull to Cu concentrate

The mathematical expression of the relationship shown in Figure 13-26 is provided by Equation 13-7:

$$\text{Cu cleaning stage Au rec.} = 88.8 * (1 - e^{-2.76 * [\text{mass pull to Cu conc.}]}) \quad [\text{Equation 13-7}]$$

To compute the projected gold recovery to the copper cleaning circuit, per Equation 13-7, a relationship predicting the mass pull to the final copper concentrate is thus required. The best one was encountered while tying it to the copper feed grade, as presented in Figure 13-27.

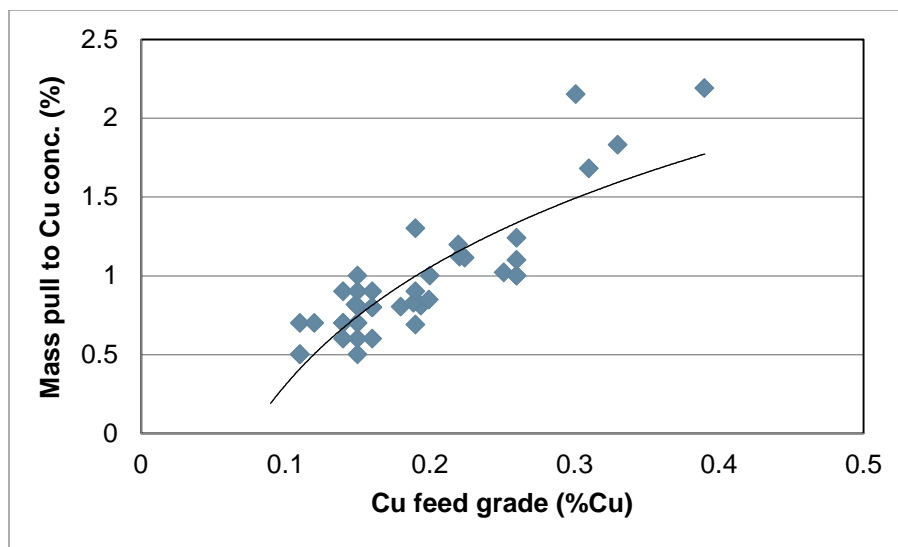

Figure 13-27: Mass pull to Cu concentrate vs Cu feed grade

Figure 13-27 contains all of the data points from both batch and LCT tests. Some of these tests did not provide a final copper concentrate grade falling within or slightly above the desired 15-18% Cu. These low concentrate grade data points were excluded for refining the mass pull to copper feed grade relationship displayed by the trend in Figure 13-28.

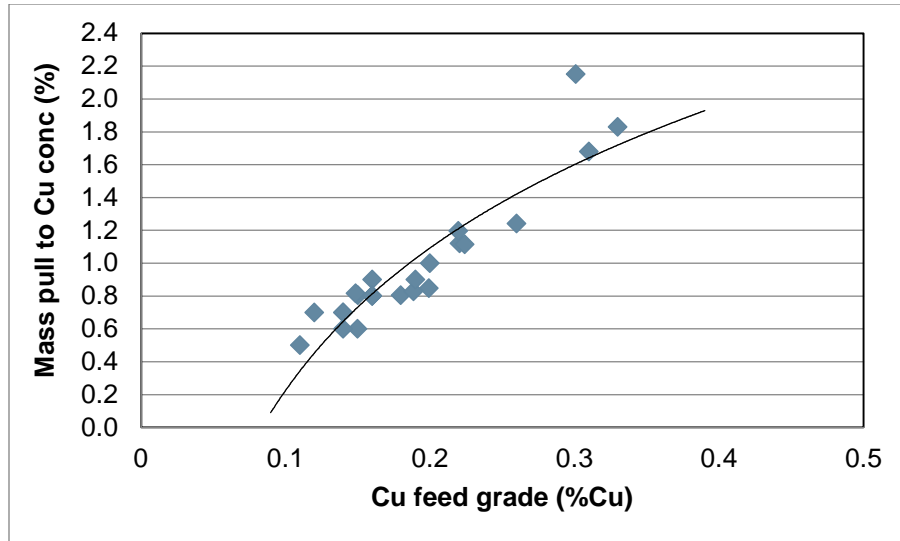

Figure 13-28: Mass pull to Cu concentrate vs Cu feed grade (filtered data)

The mathematical expression of the relationship shown in Figure 13-28 is provided by Equation 13-8:

$$\text{Cu cleaning stage Au rec.} = 3.1072 + 1.2512 \times \ln([\%Cu \text{ in feed}]) \quad [\text{Equation 13-8}]$$

Combining Equation 13-2, Equation 13-7 and Equation 13-8 allows for calculating the projected global gold recovery to the copper concentrate but based on an open cleaning circuit. The resulting trend plotted against the concentrate mass pull is shown in Figure 13-29, as the dashed line. To convert this relationship to its plant-scale equivalent, with its closed cleaning circuit generating circulating loads, consideration was given to the LCT data available. A best-fit approach was used to adjust the batch circuit recovery relationship to the LCT results.



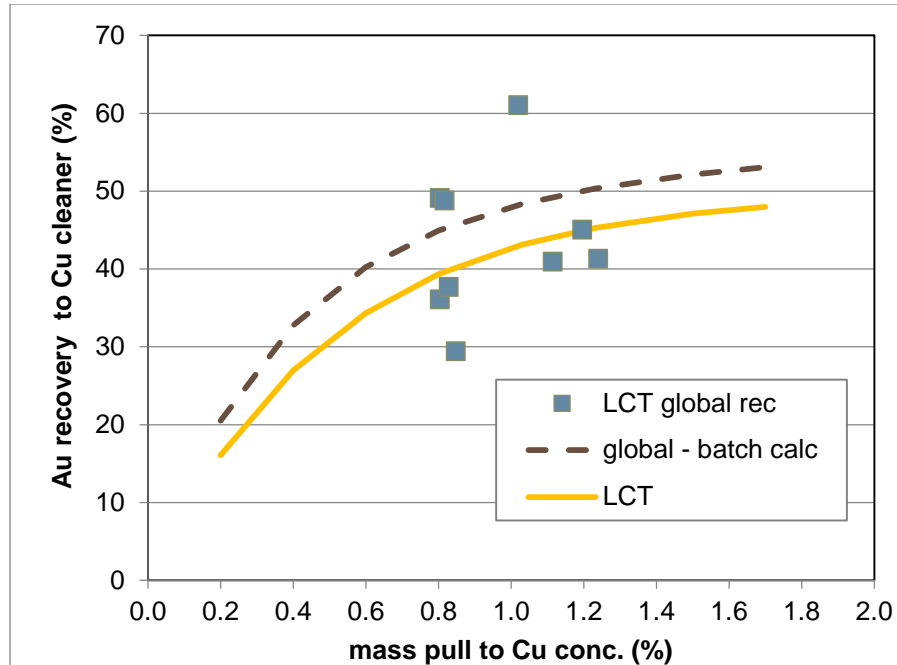

Figure 13-29: Cu cleaning circuit and global Au recovery vs mass pull to Cu concentrate

The expression related to the LCT behaviour is retained for projecting the gold recovery to the copper concentrate. Its mathematical expression is provided by Equation 13-9:

$$\text{Global Au rec.to Cu conc.} = 49.8 * (1 - e^{-1.95 * [\text{mass pull to Cu conc.}]}) \quad [\text{Equation 13-9}]$$

Although recirculation of the intermediate tailings product from a cleaning circuit, as per LCT configuration, could be expected to boost the equivalent batch circuit behaviour, this outcome is not seen here. This is likely resulting from gold values distributed not only in the recovered copper of chalcopyrite but also in the minerals that are rejected to achieve the copper grade upgrading sought. In this case, pyrite is a likely gold carrier that is being targeted for rejection by the upgrading process.

### Silver Recovery to Copper Cleaning Circuit

The silver recovery to the final copper concentrate projection is following a path similar to the one seen for gold, related to the mass pull into the final copper concentrate as per Figure 13-30.

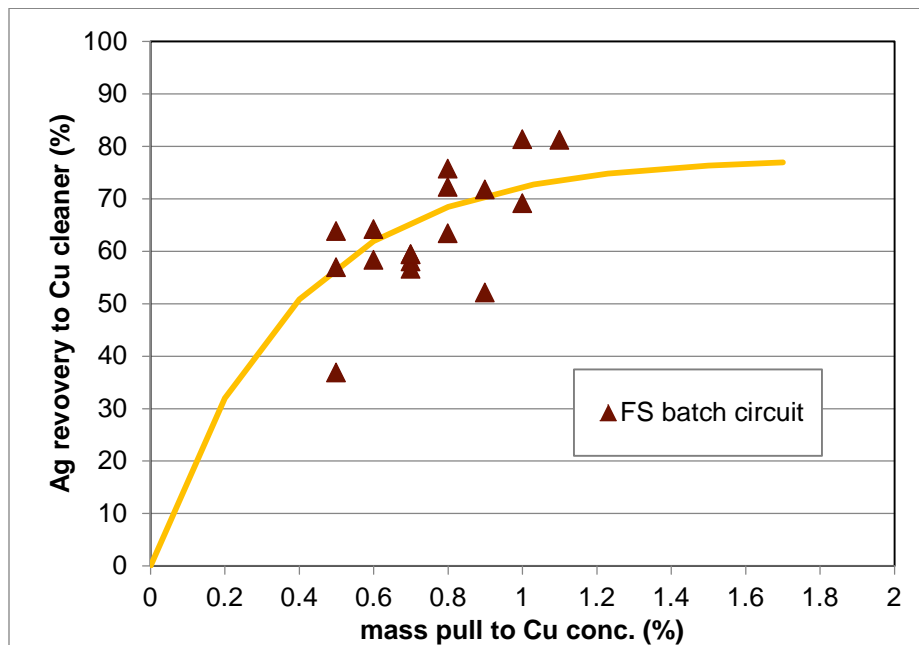

Figure 13-30: Cu cleaning circuit Au recovery vs mass pull to Cu concentrate

The mathematical expression of the relationship displayed in Figure 13-30 is provided by Equation 13-10:

$$\text{Cu cleaning stage Au rec.} = 78.8 * (1 - e^{-2.65 * [\text{mass pull to Cu conc.}]}) \quad \text{[Equation 13-10]}$$

Going through the same exercise as for gold, Figure 13-31 is prepared to show the global recovery projection for the batch circuit, through calculations, and for the global cleaning circuit equivalent, per the LCT data.

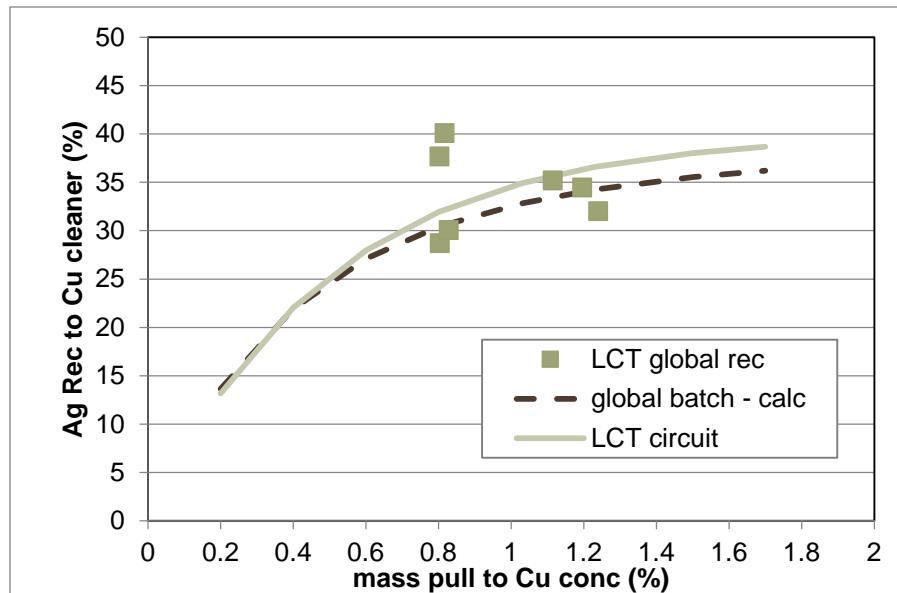

Figure 13-31: Cu cleaning circuit and global Ag recovery vs mass pull to Cu concentrate

The expression related to LCT behaviour is retained for projecting the global silver recovery to the copper concentrate. Its mathematical expression is provided by Equation 13-11:

$$\text{Global Ag rec.to Cu conc.} = 40 * (1 - e^{-2[\text{mass pull to Cu conc.}]}) \quad \text{[Equation 13-11]}$$

In this case, the adjustment from batch to LCT circuit is leading to a slight foreseen improvement to the behaviour of silver, contrary to the degradation seen for gold.

### Zinc Recovery to Copper Cleaning Circuit

The zinc recovery to the final copper concentrate is related to the zinc head grade, as shown by Figure 13-32.

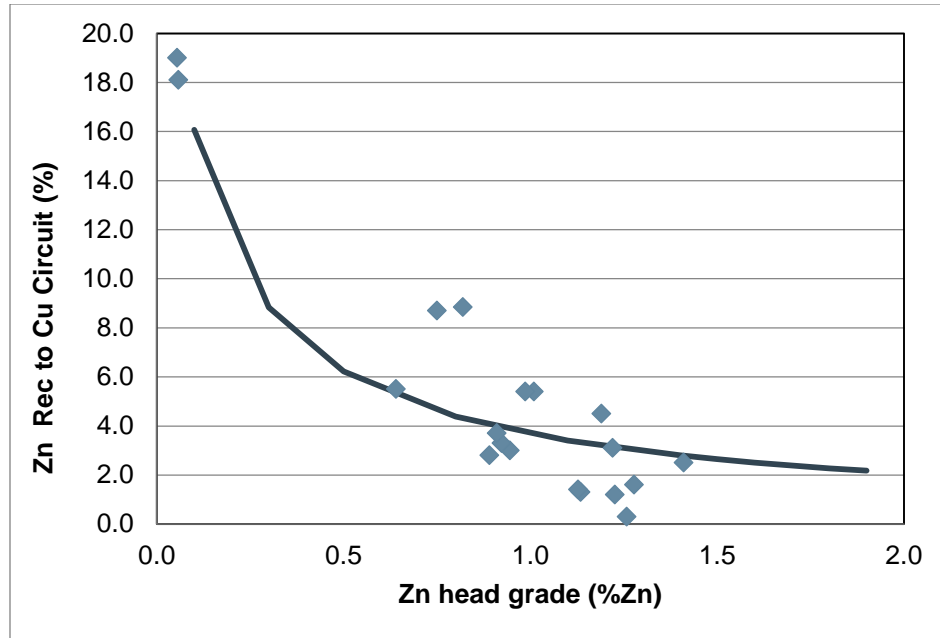

Figure 13-32: Zn recovery to Cu concentrate vs Zn head grade

The mathematical expression of this relationship is provided by Equation 13-12:

$$\text{Zn rec. to Cu conc.} = \frac{125}{(4 + 30 \times [\text{Zn head grade}]^{0.9})} \quad [\text{Equation 13-12}]$$

#### 13.4.3.3 Zinc Circuit Performance Projections

##### Zinc Circuit Zinc Recovery to Final Zinc Concentrate

As shown in Figure 13-33, a good correlation of the zinc circuit zinc recovery against the zinc circuit head grade (discounting the zinc and weight lost into the copper concentrate) was demonstrated. The data points considered to derive the regression equation excluded those that did not achieve a final concentrate grade above 48% Zn. Where much higher zinc concentrate grades were achieved with additional cleaning stages, consideration was given to the recovery obtained with the first cleaning stage providing at least this 48% Zn threshold.

The LCT trend line shown in Figure 13-33 has the mathematical expression provided by Equation 13-13:

$$\text{Zn circuit Zn rec.} = 92.9 * (1 - e^{-4.9 * [\text{Zn circuit Zn head}]}) \quad [\text{Equation 13-13}]$$

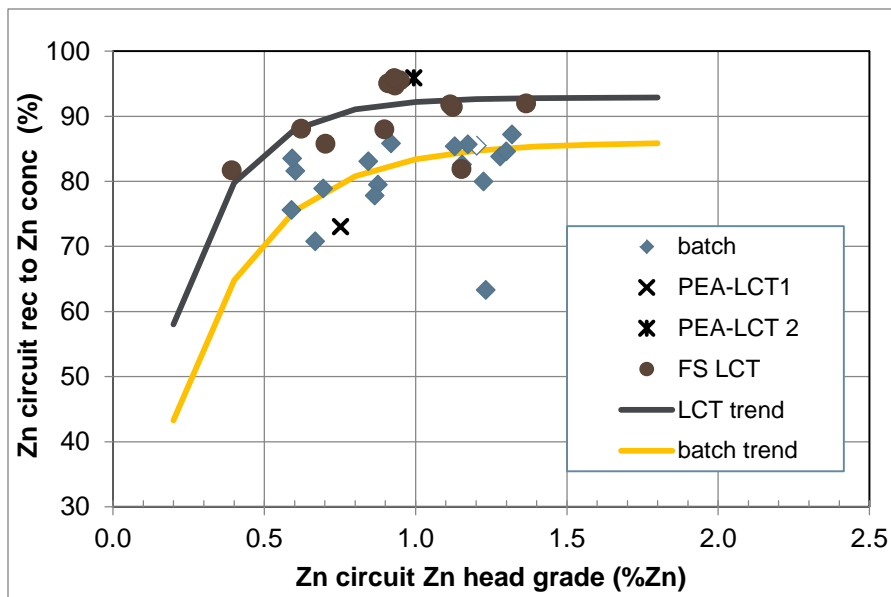

Figure 13-33: Zn circuit Zn recovery vs Zn circuit head grade

The zinc circuit head grade can be calculated once the projected final concentrate mass pull and zinc recovery to the copper concentrate are taken into account by using the equations shown earlier in this section.

The differential recovery between the batch and LCT results appears wide but it is reflecting not only the potential of picking up zinc units rejected between cleaner stages but also the additional zinc units remaining tied up in the intermediate copper cleaner stages that are not reporting to the zinc circuit feed. Their inclusion as part of the zinc circuit feed stream under a LCT configuration is likely providing easily floatable units that contribute as well to the improved LCT outcome.

### Gold Recovery to Zinc Circuit

Although the gold reporting to the zinc concentrate may not constitute a payable element in this product, any units displaced there were then not available for leaching within either the pyrite concentrate or tails streams later on.

The most plausible correlation linking expected gold recovery to the zinc concentrate is displayed in Figure 13-34, with the filtered data from FS as the triangles and the only relevant ones from the PEA as lozenges. It is showing the relationship between the gold recovery to the zinc circuit (e.g. stage recovery) with the ratio of gold to zinc feed grades at the zinc rougher feed.

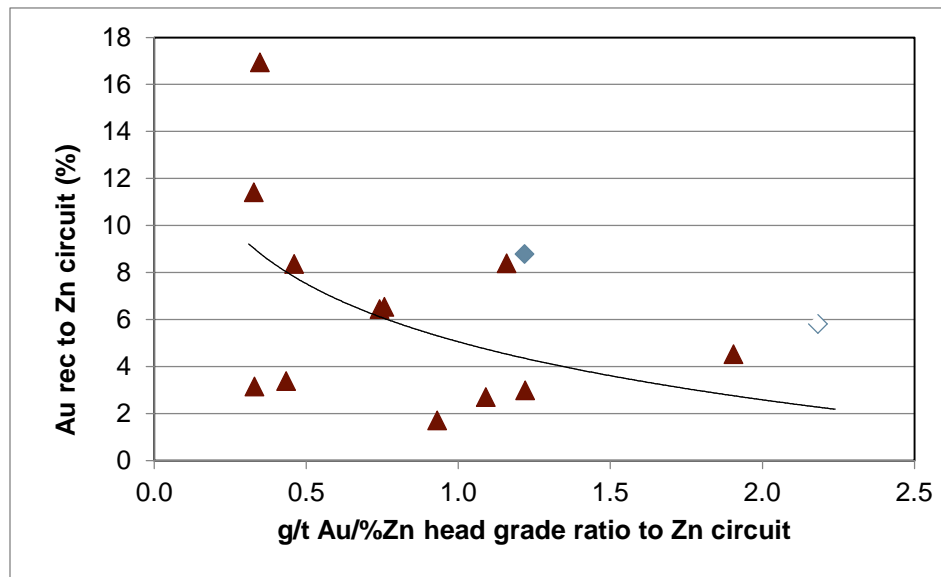

Figure 13-34: Au recovery to Zn circuit vs Au/Zn head grade ratio to Zn circuit

The fitted equation for the trend shown in Figure 13-34 is provided as Equation 13-14:

$$\text{Au rec to Zn circuit} = 5.05 - 3.562 \times \ln\left(\frac{[\text{Au head to Zn circuit}]}{[\text{Zn head to Zn circuit}]}\right)$$

[Equation 13-14]

### Silver Recovery to Zinc Circuit

A similar search for a valid relationship as for the gold recovery, either to the zinc circuit (stage recovery) or to the zinc concentrate (global recovery), was also carried out for silver. Again, this other precious metal recovery is found to be loosely tied to the precious metal to zinc ratio of feed grades to the zinc circuit, as shown in Figure 13-35.

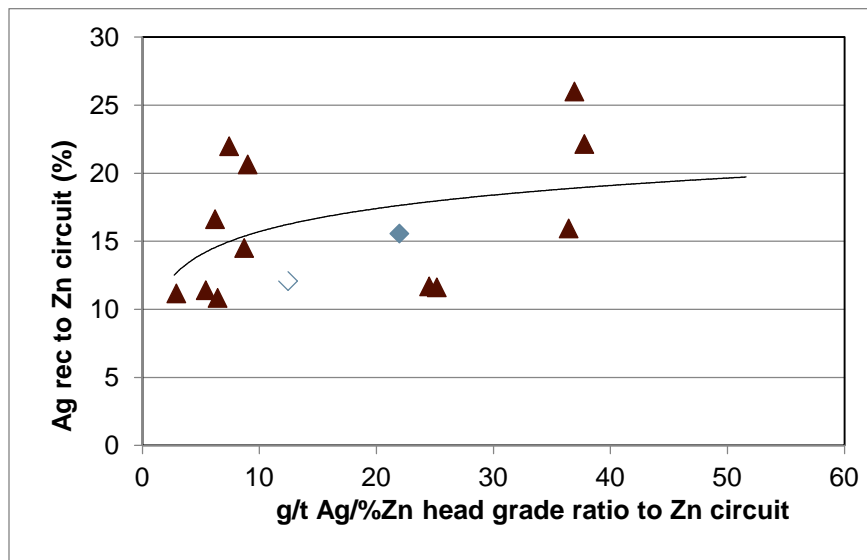

Figure 13-35: Ag recovery to Zn circuit vs Ag/Zn head grade ratio to Zn circuit

The fitted equation for the trend shown in Figure 13-35 is provided as Equation 13-15:

$$\text{Ag rec to Zn circuit} = 10.086 + 2.4448 \times \ln\left(\frac{[\text{Ag head to Zn circuit}]}{[\text{Zn head to Zn circuit}]}\right)$$

[Equation 13-15]

The equivalent global zinc recovery from the batch and locked-cycle tests considered is shown on Figure 13-36 against the same Ag:Zn ratio in the Zn circuit feed stream.



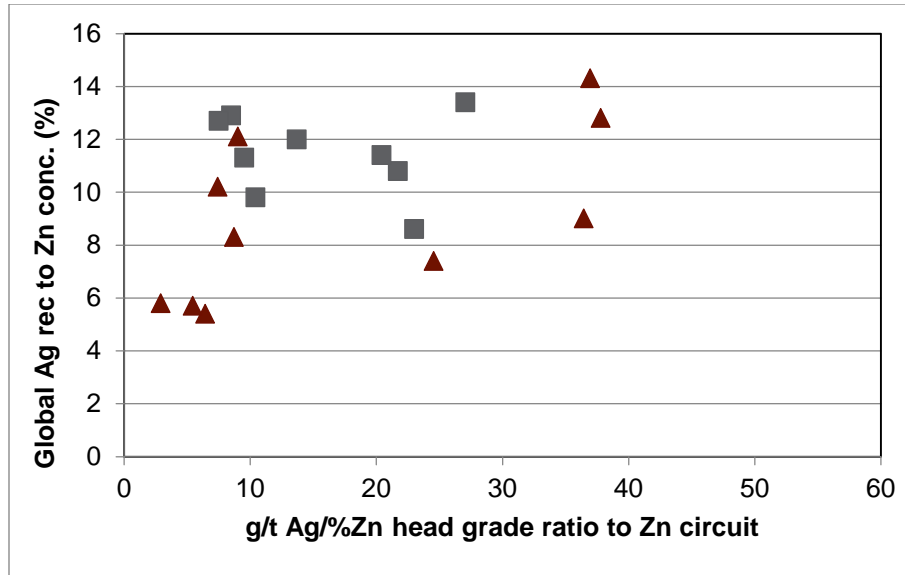

Figure 13-36: Global Ag recovery to Zn conc. vs Ag/Zn head grade ratio to Zn circuit

#### 13.4.3.4 Pyrite Circuit Performance Projections

##### Mass Pull to Pyrite Rougher Concentrate

Figure 13-37 was prepared to show the relationship between expected weight recovery to the pyrite rougher concentrate and the sulphur content in the plant feed. A linear relationship (black trend line) with a high correlation coefficient is displayed, with its expression as per Equation 13-16:

$$\text{Mass pull to Py conc.} = 14.64 + 1.4739 \times [\text{S head grade}] \quad [\text{Equation 13-16}]$$

The relationship established for the PEA is also shown as the red trend, showing a slight shift upward, resulting from the additional testwork completed during the FS. This relationship is important for establishing the design criteria applicable to the scale of the pyrite concentrate and tailings leaching, CIP and detoxification circuits.

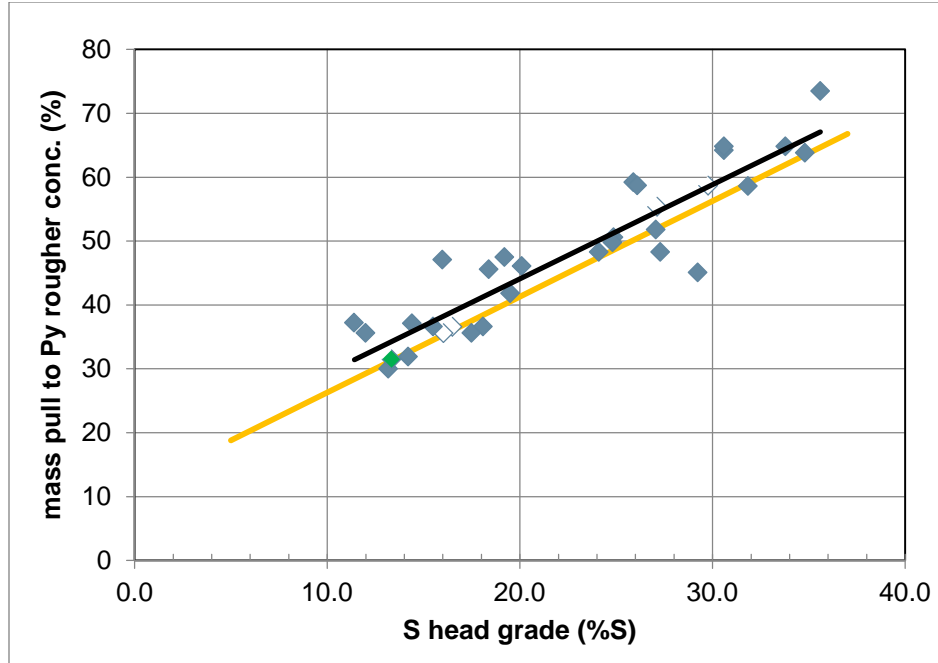

Figure 13-37: Pyrite rougher weight recovery to sulphide content

### Gold Recovery to Pyrite Rougher Concentrate

The partial gold recovery to the pyrite rougher concentrate (e.g. rougher circuit recovery) vs the sulphur grade at the plant feed is displaying a strong relationship, as illustrated in Figure 13-38. The mathematical expression of the best fit curve shown is as per Equation 13-17:

$$\text{Au partial rec. to Py rougher conc.} = 95.8 * (1 - e^{-0.135 * [\%S \text{ in feed}]}) \quad [\text{Equation 13-17}]$$

The data points represented by circles on Figure 13-38 are related to FS-stage data whereas the diamonds are from the PEA.

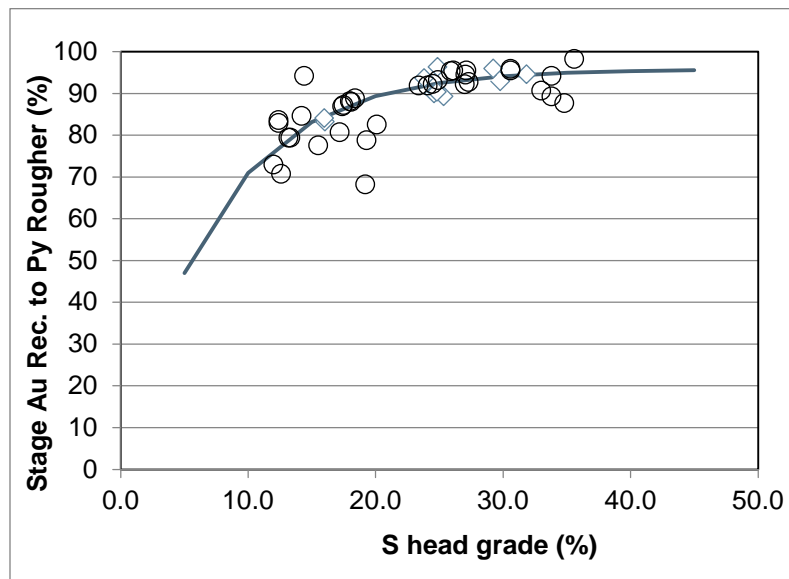

Figure 13-38: Au partial recovery to pyrite rougher concentrate versus S head grade

### Silver recovery to pyrite rougher concentrate

The partial silver recovery to the pyrite rougher concentrate is linked to the sulphur feed grade, as found for the mass and gold recoveries. This relationship is illustrated in Figure 13-39 and the mathematical equation underlying the best-correlation trend is as per Equation 13-18.

$$\text{Ag partial rec. to Py rougher conc.} = 87.9 * (1 - e^{-0.18 * [\%S \text{ in feed}]}) \quad [\text{Equation 13-18}]$$

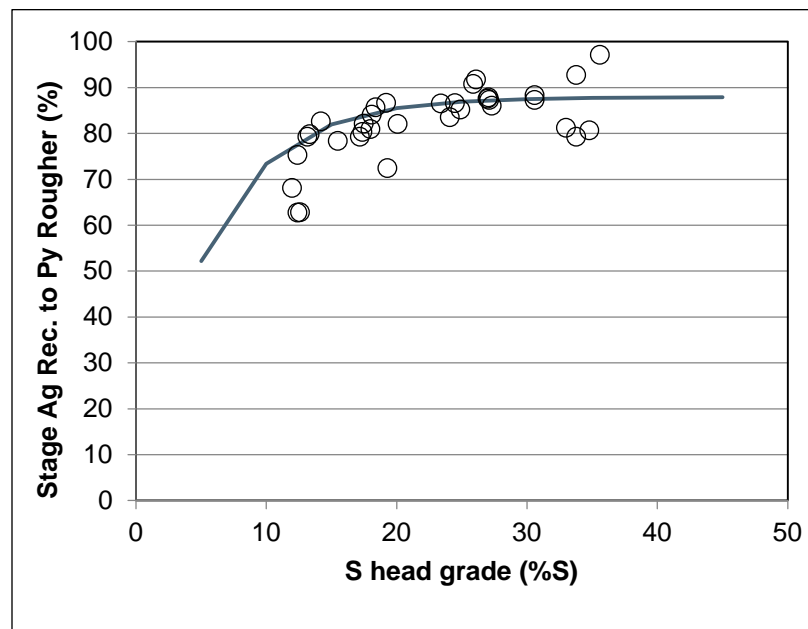

Figure 13-39: Ag partial recovery to pyrite rougher concentrate versus S head grade

## 13.5 Leaching Testwork

### 13.5.1 Program Overview

At the PEA stage of the Horne 5 Project, a series of bottle roll leaching tests was conducted on the pyrite flotation concentrate and tails.

It was soon realized that, prior to leaching, the pyrite concentrate required regrinding from an  $F_{80}$  of approximately 50-55  $\mu\text{m}$  to a target grind  $P_{80}$  of 10-12  $\mu\text{m}$ . This was carried out in an attrition mill. The reground concentrates were then re-pulped to 35% (w/w) solids before undergoing pre-treatment. The pre-treatment consisted of conditioning the slurry with lime and varying additions of oxygen as well as testing the influence of lead nitrate. The pre-treatment tested varied from 8 to 16 hours. The leaching cycle was carried out from 24 to 72 hours with intermittent solution sample collection.

Leaching tests on the pyrite flotation tailings were conducted without regrinding or pre-treatment. The test conditions varied the amount of lime and cyanide added, as well as the duration of the leach cycle.

The pre-treatment and leaching conditions used for each leaching test are presented in Table 13-22 and Table 13-23 for the pyrite concentrates and pyrite flotation tailings respectively. The bulk leaching conditions with the LCT2 locked cycle test products, as carried out to produce a large volume of concentrate and tailings material for paste backfill testwork, are presented in Table 13-24. Initial scoping tests were performed using a long pre-treatment with the addition of oxygen and high concentrations of lime and lead nitrate. High concentrations of cyanide were also used to determine the maximum extraction of gold. Similar conditions were benchmarked from plant-scale operations processing ultrafine sulphide concentrates containing gold tellurides.

Table 13-22: Optimization of leaching conditions for pyrite flotation concentrates – PEA Phase

Test No.	Comp.	Feed	Target Grind (µm)	Preconditioning				Leaching			
				Time (h)	DO (ppm)	pH	Pb(NO <sub>3</sub> ) <sub>2</sub> (kg/t)	Time (h)	DO (ppm)	pH	NaCN (g/L) Initial / Maintained
CN5	M3	F13 (Py conc.)	10 - 12	12	0.1 -0.3	12	3	72	3 - 5	12	2.0 / 1.5
CN6	M1/M2	F14 (Py conc.)	10 - 12	12	0.1	12	3	72	10 - 15	12	2.0 / 1.5
CN7	M1/M2	F21 (Py conc.)	10 - 12	16	0.1	12	3	72	5 - 15	12	2.0 / 1.5
CN8	M3	F20 (Py conc.)	10 - 12	16	0.1	12	3	72	5 - 15	12	2.0 / 1.5
CN9	M3	F23 (Py conc.)	10 - 12	16	<0.1	12	3	72	5 - 15	12	2.0 / 1.5
CN10	M1/M2	F24 (Py conc.)	10 - 12	16	<0.1	12	3	72	5 - 15	12	2.0 / 1.5
CN13	MCA	LCT1 (Py conc.)	10 - 12	15	<0.1	12	1	72	5 - 20	12	2.0 / 1.5
CN14	MCA	LCT1 (Py conc.)	10 - 12	15	<0.1	12	3	72	3 - 12	12	2.0 / 1.5
CN15	MCA	LCT1 (Py conc.)	18 - 20	15	<0.1	12	1	72	5 - 25	12	2.0 / 1.5
CN16	MCA	LCT1 (Py conc.)	10 - 12	15	<0.1	12	3	72	5 - 11	12	2.0 / 1.5
CN17	MCA	LCT1 (Py conc.)	10 - 12	15	<0.1	12	3	72	15 - 28	12	2.0 / 1.5
CN31	MCA	LCT1 (Py conc.)	18 - 20	12	<0.1	12	1	24	7 - 20	400 ppm CaO	2.0 / 1.5
CN32	MCA	LCT1 (Py conc.)	10 - 12	12	<0.1	6 kg/t CaO	1	24		400 ppm CaO	2.0 / 1.5
CN32RL	MCA	CN32 residue	-	-	-	-	-	24	5 - 15	11 - 11.5	0.5
CN33	MCA	LCT1 (Py conc.)	10 - 12	8	<0.1	6 kg/t CaO	1	24	14 - 24	300 ppm CaO	2.0 / 1.5
CN34	MCA	LCT1 (Py conc.)	18 - 20	8	<0.1	6 kg/t CaO	1	24	15 - 20	400 ppm CaO	2.0 / 1.5
CN35	MCA	LCT1 (Py conc.)	18 - 20	8	0.2	6 kg/t CaO	1	24	20	130 ppm CaO	2.0 / 1.5
CN36	MCA	F34 (Py conc.)	10 - 12	8	0.1	10 kg/t CaO	1	24	5 - 15	200-400 ppm CaO	2.0 / 1.5
CN37	MCA	F34 (Py conc.)	18 - 20	8	0.1	10 kg/t CaO	1	24	20	200-400 ppm CaO	2.0 / 1.5
CN38	MCA	F34 (Py conc.)	10 - 12	8	0.1	10 kg/t CaO	1	24	10	200-400 ppm CaO	1.2 / 0.8 / decay >5h
CN38RL	MCA	CN38 residue	-	-	-	-	-	24	5 - 15	11 - 11.5	0.5
CN41	MCB	LCT2 (Py conc.)	12	8	3	6 kg/t CaO	1	24	5 - 15	500 ppm (5 hrs), pH 10.8	1.4 / 1.0 / decay >5h
CN42	MCB	LCT2 (Py conc.)	12	8	4	15 kg/t CaO	1	24	5 - 15	500 ppm (5 hrs), pH 10.8	1.4 / 1.0 / decay >5h
CN45	MCB	LCT2 (Py conc.)	12	4	14	10 kg/t CaO	1	24	5 -15	500 ppm (5 hrs), pH 10.8	1.4 / 1.0 / decay >5h
CN46	MCB	LCT2 (Py conc.)	12	12	22	10 kg/t CaO	1	24	5 -15	500 ppm (5 hrs), pH 10.8	1.4 / 1.0 / decay >5h
CN47	MCB	LCT2 (Py conc.)	12	8	9	10 kg/t CaO	1	24	>20	500 ppm (5 hrs), pH 10.8	1.4 / 1.0 / decay >5h
CN50	MCB	LCT2 (Py conc.)	12	8	<1	10 kg/t CaO	1	24	5 -15	500 ppm (5 hrs), pH 10.8	1.4 / 1.0 / decay >5h
CN52	MCB	LCT2 (Py conc.)	12	8	<1	10 kg/t CaO	0	24	10	11.5	1.4 / 1.0 / decay >5h
CN52R	MCB	LCT2 (Py conc.)	12	8	<1	10 kg/t CaO	0	24	10	11.5	1.4 / 1.0 / decay >5h
CN53	MCB	LCT2 (Py conc.)	12	8	<1	10 kg/t CaO	0.5	24	10	11.5	1.4 / 1.0 / decay >5h
CN54	MCB	LCT2 (Py conc.)	12	8	<1	10 kg/t CaO	0.75	24	10	11.5	1.4 / 1.0 / decay >5h

Table 13-23: Leaching conditions for pyrite flotation tailings – PEA Phase

Test No.	Comp.	Feed	Leaching				
			Time (h)	DO (ppm)	pH	NaCN (g/L) Initial / Maintained	Pb(NO <sub>3</sub> ) <sub>2</sub> (kg/t)
CN11	M1/M2	F24 (Py tail)	48	-	10 -10.5	1.0 / 0.5	0.25
CN12	M1/M2	F24 (Py tail)	48	-	12	2.0 / 1.0	0.25
CN18	MCA	LCT1 (Py tail)	24	0.2 L/min O <sub>2</sub>	10.5 - 11	0.4	0.25
CN19	MCA	LCT1 (Py tail)	24	0.2 L/min O <sub>2</sub>	10.5 - 11	0.4	0.25
CN43	MCB	LCT2 (Py tail)	12	0.2 L/min O <sub>2</sub>	11 - 11.4	0.4 / 0.1	0.25
CN44	MCB	LCT2 (Py tail)	12	0.2 L/min O <sub>2</sub>	10.5 - 11	0.4 / 0.1	-
CN48	MCB	LCT2 (Py tail)	12	5 – 15	10.5 - 11	0.3 / 0.1	-
CN49	MCB	LCT2 (Py tail)	12	5 – 15	10.5 - 11	0.2 / 0.1	-
CN51	MCB	LCT2 (Py tail)	12	5 – 15	10.5 - 11	0.3 / 0.1	-
CN55	MCB	LCT2 (Py tail)	12	5 – 15	10.5 - 11	0.15 / 0.1	-
CN56	MCB	LCT2 (Py tail)	12	5 – 15	10.5 - 11	0.12 / 0.1	-

Table 13-24: Leaching conditions for large-volume sample production of pyrite concentrate and pyrite flotation tailings – PEA Phase

Test No.	Comp.	Feed	Target Grind (µm)	Pre-oxidation					Leaching			
				Time (h)	DO (ppm)	pH	Pb(NO <sub>3</sub> ) <sub>2</sub> (kg/t)		Time (h)	DO (ppm)	pH	NaCN (g/L) Initial / Maintained
CN39	MCB	LCT2 (Py conc.)	12	8	6 - 8	CaO =10kg/t	1.0	n/a	24	5 - 15	CaO = 500ppm, decay past 5 hrs	1.4 / 1.0 / decay after 2 hrs
CN40	MCB	LCT2 (Py tail)	n/a	n/a	n/a	n/a	n/a	0.25	24	0.2 L/min O <sub>2</sub>	10.5 - 11	0.4 / 0.4 then decay past 5 hrs



Phase 1 of the FS testwork program included leaching optimization tests undertaken using the tails and the concentrate of the pyrite flotation locked-cycle tests for each composite sample of the phase testwork (SS2021, SS2022 and SS2025). While leaching test of the pyrite tails were done using the sample as is, the pyrite concentrate was reground to about 10 µm to 15 µm prior to leaching. The following parameters were tested for the pyrite concentrate:

- Lead nitrate (“Pb(NO<sub>3</sub>)<sub>2</sub>”) addition to pre-oxidation;
- Pre-oxidation duration;
- Aeration rate in pre-oxidation;
- Regrind intensity;
- Cyanide concentration in leaching;
- Aeration rate in leaching;
- Leach time.

Tested parameters were slightly different for the pyrite tails:

- Cyanide concentration in leaching;
- Aeration rate in leaching;
- Leach time.

Table 13-25 presents tested leaching conditions for the pyrite flotation concentrate while Table 13-26 covers the same data for pyrite flotation tails. As a variant from the condition used during the PEA phase, all pyrite concentrate leaching tests for Phase 1 and Phase 2 were performed at 35°C to reflect the slurry temperature rise expected to occur in the industrial-scale regrinding step since slurry temperature can affect the leach kinetics, reagent consumption and cyanide degradation to thiocyanate.

The variability tests of the six composites involved in Phase 2 were all performed under the exact leaching conditions, reflecting optimized conditions which evolved from the Phase 1 trial results. These are:

- Pre-oxidation duration of 7 hours;
- Aeration rate in pre-oxidation with 250 ml/min of air only;
- Regrind intensity to yield a P<sub>80</sub> of 12 µm;
- Cyanide concentration in leaching starting at 1.0 g/L NaCN, then allowing to drop to 0.7 g/L during the first five hours and to 0.2 g/L thereafter;
- pH maintained between 11.5 and 12.0;
- Aeration rate in leaching with oxygen to maintain DO concentration between 3 mg/L and 5 mg/L;
- Leach duration of 16 hours.

Table 13-25: FS Optimization of leaching conditions for pyrite flotation concentrates – FS testwork

Composite	Leach Test No.	Feed Size P80, µm	Pulp Density % solids	Pre-oxidation				Leaching					
				Time h	CaO kg/t	Lead Nitrate kg/t	O <sub>2</sub> or air flow (mL/min)	DO ppm	Time h	DO, ppm			O <sub>2</sub> or air flow (mL/min)
										Target	Range	Ave.	
SS2025 (Pyrite Flotation Concentrate LCT 1+2)	CN7	10.2	35	8	10	0	250 air+ O <sub>2</sub>	<1	24	n/a	0.1-5.9	2.6	750 O <sub>2</sub>
	CN31	14	35	8	10	0	500 O <sub>2</sub>	<1	16	15	13.5-14.8	14.3	800 O <sub>2</sub>
	CN8	11.3	35	8	10	0.2	250 air+ O <sub>2</sub>	<1	24	n/a	0-7.7	3.6	750 O <sub>2</sub>
	CN9	11.2	35	4	10	0.2	250 air+ O <sub>2</sub>	<1	24	n/a	0-4.5	2.2	750 O <sub>2</sub>
	CN10	12.2	35	8	10	0.4	250 air+ O <sub>2</sub>	<1	24	n/a	0-17.9	5.6	750 O <sub>2</sub>
	CN30	14	35	8	10	1	500	<1	24	15	7.8-18.2	13.1	800 O <sub>2</sub>
	CN36	16	35	8	10	1	500	<1	24	3-5	2.5-8.7	4.4	500 air + O <sub>2</sub>
	CN37	15	35	8	10	0	500	<1	24	3-5	2.6-3.5	3.1	500 air + O <sub>2</sub>
	CN42	12	35	8	10	0	500 air + O <sub>2</sub>	<1	16	n/a	7.9-14.5	13.1	800 O <sub>2</sub>
	CN43	12	35	8	10	0	250 air + O <sub>2</sub>	<1	24	n/a	1.3-5.1	3.5	400-1000 O <sub>2</sub>
	CN46	12	35	7	10	0	250 O <sub>2</sub>	<1	16	15	5.8-13.1	9.7	800-1050 O <sub>2</sub>
CN47	12	35	7	10	0	250 O <sub>2</sub>	<1	16	3-5	0.5-3.2	1.9	1000 O <sub>2</sub>	
SS2021 (Pyrite Flotation Concentrate LCT 3+4)	CN11	11.9	35	8	10	0	250 air+ O <sub>2</sub>	<1	24	n/a	0.1-10.8	4.4	750 O <sub>2</sub>
	CN33	14	35	8	10	0	500	<1	16	15	13.6-21.4	17.2	800 O <sub>2</sub>
	CN12	12.9	35	8	10	0.2	250 air+ O <sub>2</sub>	<1	24	n/a	0.1-21.9	8.6	750 O <sub>2</sub>
	CN13	13.3	35	4	10	0.2	250 air+ O <sub>2</sub>	<1	24	n/a	0-21.9	7.5	750 O <sub>2</sub>
	CN14	13.4	35	8	10	0.4	250 air+ O <sub>2</sub>	<1	24	n/a	2.4-9.2	5.7	750 O <sub>2</sub>
	CN32	14	35	8	10	1	500 O <sub>2</sub>	<1	24	15	3.6-17.6	13.7	800 O <sub>2</sub>
	CN38	15	35	8	10	1	500 O <sub>2</sub>	<1	24	3-5	3.7-4.4	4.0	500 air + O <sub>2</sub>
CN39	15	35	8	10	0	500 O <sub>2</sub>	<1	24	3-5	3.8-9.2	5.5	500 air + O <sub>2</sub>	
SS2022 (Pyrite Flotation Concentrate LCT 5+6)	CN15	10.0	35	8	10	0	250 air+ O <sub>2</sub>	<1	24	n/a	0-13.9	4.5	750 O <sub>2</sub>
	CN35	14	35	8	10	0	500 O <sub>2</sub>	<1	16	15	14.3-16.9	15.4	800 O <sub>2</sub>
	CN16	10.7	35	8	10	0.2	250 air+ O <sub>2</sub>	<1	24	n/a	0.1-9.3	3.9	750 O <sub>2</sub>
	CN17	11.5	35	4	10	0.2	250 air+ O <sub>2</sub>	<1	24	n/a	0-11.3	2.3	750
	CN18	11.7	35	8	10	0.4	250 air+ O <sub>2</sub>	<1	24	n/a	0.1-6.3	1.9	750 O <sub>2</sub>
	CN34	14	35	8	10	1	500 O <sub>2</sub>	<1	24	15	13.7-25.1	16.6	800 O <sub>2</sub>
	CN40	15	35	8	10	1	500 O <sub>2</sub>	<1	24	3-5	2-3	2.7	500 air + O <sub>2</sub>
	CN41	16	35	8	10	0	500 O <sub>2</sub>	<1	24	3-5	3.2-4	3.3	500 air + O <sub>2</sub>
	CN44	11.8	35	8	10	0	500 air + O <sub>2</sub>	<1	16	n/a	4.0-14.2	14.2	800 O <sub>2</sub>
	CN45	11.4	35	8	10	0	250 air + O <sub>2</sub>	<1	24	n/a	2.5-4.1	3.9	400-1000 O <sub>2</sub>
	CN48	10	35	7	10	0	250 O <sub>2</sub>	<1	16	15	5.9-18.1	10.5	800-1250 O <sub>2</sub>
CN49	10	35	7	10	0	250 O <sub>2</sub>	<1	16	3-5	<1-8.3	4.7	400-1000 O <sub>2</sub>	

Composite	Leach Test No.	Feed Size P80, µm	Pulp Density % solids	Pre-oxidation					Leaching				
				Time h	CaO kg/t	Lead Nitrate kg/t	O <sub>2</sub> or air flow (mL/min)	DO ppm	Time h	DO, ppm			O <sub>2</sub> or air flow (mL/min)
										Target	Range	Ave.	
H5-P2-C1	CN50	12	35	7	20.5	0	250 air	<1	16	3-5	0.9-7.5	6.2	1000 O <sub>2</sub>
H5-P2-C2	CN51	12.1	35	7	18.0	0	250 air	<1	16	3-5	3.1-7.1	5.6	800-1000 O <sub>2</sub>
H5-P2-C3	CN52	12	35	7	22.0	0	250 air	<1	16	3-5	3.0-6.9	5.4	800-1000 O <sub>2</sub>
H5-P2-C4	CN53	11.5	35	7	20.5	0	250 air	<1	16	3-5	5.0-8.1	6.2	700-1000 O <sub>2</sub>
H5-P2-C5	CN54	10.9	35	7	17.1	0	250 air	<1	16	3-5	5.8-6.2	6.0	800-1000 O <sub>2</sub>
H5-P2-C6	CN55	11.9	35	7	21.0	0	250 air	<1	16	3-5	4.6-9.9	7.4	750-1000 O <sub>2</sub>

Table 13-26: FS Optimization of leaching conditions for pyrite flotation tails – FS Phase 1 testwork

Composite	Test No.	Feed Size	Pulp	Leaching					O <sub>2</sub> or air flow (mL/min)
			Density	Time	pH	NaCN	DO, ppm		
		P80, µm	% solids	h		g/L	Range	Ave.	
SS2025 Pyrite Flot. Tails LCT 1+2	CN19	46	45	12	10.5-11	0.2-0.1-0.075	8.7-24.1	13.6	200 air + O <sub>2</sub>
	CN20	46	45	12	10.5-11	0.2-0.1-0.075	8.3-21.4	13.9	1000 air + O <sub>2</sub>
	CN27	46	45	8	10.5-11	0.2-0.1-0.075	8.2 - 26.6	18.6	200 O <sub>2</sub>
SS2022 Pyrite Flot. Tails LCT 3+4	CN21	51	45	12	10.5-11	0.2-0.1-0.075	9.4 - 23.1	13.8	200 air + O <sub>2</sub>
	CN22	51	45	12	10.5-11	0.2-0.1-0.075	8.7 - 16.2	12.7	1000 air + O <sub>2</sub>
	CN28	51	45	8	10.5-11	0.2-0.1-0.075	12.5 - 21.6	18.3	200 O <sub>2</sub>
SS2021 Pyrite Flot. Tails LCT 5+6	CN23	50	45	12	10.5-11	0.2-0.1-0.075	7.3 - 16.4	10.9	200 air + O <sub>2</sub>
	CN24	50	45	12	10.5-11	0.2-0.1-0.075	7.3 - 14.2	11.7	1000 air + O <sub>2</sub>
	CN29	50	45	8	10.5-11	0.2-0.1-0.075	19.3 - 22.1	20.6	200 O <sub>2</sub>

### 13.5.2 Pyrite Concentrate Leaching Test Results

#### PEA Phase

The results for the leach tests described in Table 13-22 are presented in Table 13-27. The associated gold leaching kinetics are illustrated in Figure 13-40.

Table 13-27: Results for pyrite concentrate leaching tests – PEA Phase

Comp.	Test	Float Test Product	Actual Grind Size (µm)	Reagent Consumption		Au Rec (%)	Tailings Grade Au (g/t)	Ag Rec (%)	Tailings Grade Ag (g/t)
				NaCN (kg/t)	CaO (kg/t)				
M1/M2	CN6	F14	14	5.9	20.9	86.2	0.24	62.3	1
	CN7	F21	10	4.5	33.0	81.3	0.29	73.5	<1
	CN10	F24	10	5.3	22.8	88.7	0.18	90.1	1
M3	CN5	F13	8	6.2	18.7	84.4	0.36	90.4	3
	CN8	F20	9	4.4	35.3	84.8	0.26	83.3	6
	CN9	F23	9	5.8	22.6	81.9	0.26	84.9	4
MCA	CN13	LCT1	9.8	2.8	28.6	75.1	0.29	83.2	3
	CN14	LCT1	9.8	2.8	24.2	74.0	0.32	85.4	3
	CN15	LCT1	9.8	3.1	26.4	74.8	0.29	83.4	3
	CN16	LCT1	11	2.7	22.1	74.3	0.29	84.0	3
	CN17	LCT1	9.8	5.0	25.4	75.3	0.28	83.2	3
	CN31	LCT1	16.5	1.9	7.29	68.7	0.41	86.4	2
	CN32	LCT1	12.6	2.5	7.93	71.9	0.33	86.2	2
	CN32RL	CN32 residue	12.6	2.6	14.5	5.4	0.31 <sup>(1)</sup>	-	-
	CN33	LCT1	12.6	2.8	7.92	72.9	0.33	86.0	2
	CN34	LCT1	16.5	2.0	6.91	66.8	0.40	84.0	3
	CN35	LCT1	16.5	1.9	6.59	65.5	0.40	85.0	3
	CN36	F34	10.2	2.5	11.0	81.2	0.31	91.1	1
	CN37	F34	18.6	1.6	10.7	71.3	0.50	90.0	2
	CN38	F34	10.2	1.8	11.0	79.7	0.34	88.4	2
CN38RL	CN38 residue	10.2	2.9	16.1	12.3	0.30 <sup>(1)</sup>	-	-	

Comp.	Test	Float Test Product	Actual Grind Size (µm)	Reagent Consumption		Au Rec (%)	Tailings Grade Au (g/t)	Ag Rec (%)	Tailings Grade Ag (g/t)
				NaCN (kg/t)	CaO (kg/t)				
MCB	CN39	LCT2	12	3.6	12.7	76.2	0.45	82.3	3
MCB	CN41	LCT2	12	1.9	7.5	79.1	0.38	84.7	3
MCB	CN42	LCT2	12	1.4	13.8	78.6	0.39	80.0	4
MCB	CN45	LCT2	12	4.4	18.3	79.3	0.36	-	-
MCB	CN46	LCT2	12	3.8	21.9	78.7	0.36	-	-
MCB	CN47	LCT2	12	3.5	17.7	77.8	0.40	-	-
MCB	CN50	LCT2	12	2.1	10.6	80.3	0.36	83.7	3
MCB	CN52	LCT2	12	1.7	10.8	80.1	0.36	76.5	5
MCB	CN52R	LCT2	12	1.8	10.8	79.9	0.36	-	-
MCB	CN53	LCT2	12	1.7	10.7	79.8	0.37	76.7	5
MCB	CN54	LCT2	12	1.8	11.1	80.0	0.37	82.9	3

(1) Residue grade calculated based on additional extraction measured in the leachate.

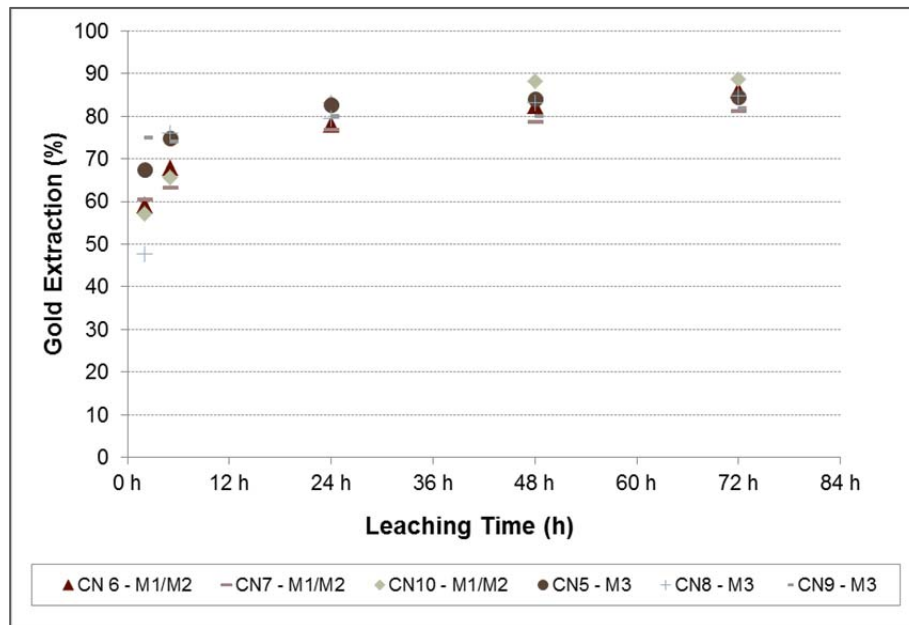

Figure 13-40: Au leaching kinetics for pyrite concentrate (Tests CN5-10)

Relatively consistent results were obtained from the leaching of both the M1/M2 blend and M3 concentrates (tests CN5-10), independent of the variations in pre-treatment conditions.

Additional testwork conducted on the LCT1, LCT2 and F34 (MCB blend) pyrite concentrates aimed at reducing reagent dosing for lime, cyanide, lead nitrate and oxygen, as well as reducing the retention time for pre-aeration and leaching.

The following preliminary indications of optimum conditions for leaching the Horne 5 pyrite concentrate were drawn at the close of the PEA:

- Pre-treatment lime addition of 10 kg/t;
- Lead nitrate addition is not required in the pre-treatment;
- Leach residence time of 24 hours;
- NaCN addition to leach ~1.2 g/L initially, allowed to decay below 0.8 g/L after 5 hours;
- Addition of a mixture of air/oxygen in the pre-treatment, with resulting DO of less than 1 ppm;
- Addition of oxygen in the leaching leading to DO of 10-15 ppm.

### FS Stage – Phase 1 and Phase 2

The results for the leach tests presented in Table 13-25 are presented in Table 13-28. The typical gold and silver leaching kinetics for Phase 1 are illustrated in Figure 13-41 and Figure 13-42, respectively.

Table 13-28: Results for pyrite concentrate leaching tests – FS Phase 1 and Phase 2

Comp.	Test #	Flotation Test Product	Actual Grind Size (µm)	Reagent Consumption		Au Rec <sup>(1)</sup> (%)	Tailings Grade Au (g/t)	Ag <sup>(1)</sup> Rec (%)	Tailings Grade Ag (g/t)
				NaCN (kg/t)	CaO (kg/t)				
SS2021	CN11	LCT 3+4	11.9	1.74	17.7	88.5	0.25	90.0	1.7
	CN12		12.9	1.64	16.3	87.7	0.27	90.3	1.6
	CN13		13.3	1.74	15.8	87.8	0.27	91.1	1.5
	CN14		13.4	1.61	17.4	87.7	0.27	91.6	1.4
SS2022	CN15	LCT 5+6	10.0	2.04	18.8	82.9	0.19	84.2	2.8
	CN44		11.8	2.29	17.0	---	0.26	---	2.8
	CN45		11.4	2.21	21.5	76.0	0.25	83.2	3.1
	CN48		10.7	2.23	16.7	80.1 <sup>(1)</sup>	0.23	n/a	n/a
	CN49		10.7	2.01	15.3	78.0 <sup>(1)</sup>	0.24	n/a	n/a
	CN16		10.7	2.03	19.8	81.4	0.21	86.6	2.4
	CN17		11.5	2.13	17.0	81.0	0.21	86.5	2.4

Comp.	Test #	Flotation Test Product	Actual Grind Size (µm)	Reagent Consumption		Au Rec <sup>(1)</sup> (%)	Tailings Grade Au (g/t)	Ag <sup>(1)</sup> Rec (%)	Tailings Grade Ag (g/t)
				NaCN (kg/t)	CaO (kg/t)				
	CN18		11.7	2.00	16.8	80.4	0.22	87.2	2.3
SS2025	CN7	LCT 1+2	10.2	1.92	17.1	77.0	0.29	84.0	2.1
	CN42		11.7	2.32	15.6	---	0.30	---	2.1
	CN43		11.8	2.24	19.1	75.5	0.30	82.4	2.4
	CN46		12.3	2.24	19.1	75.6 <sup>(1)</sup>	0.32	n/a	n/a
	CN47		12.3	2.05	14.8	74.9 <sup>(1)</sup>	0.33	n/a	n/a
	CN8		11.3	1.90	18.5	78.7	0.29	84.8	2.0
	CN9		11.2	2.01	18.1	78.1	0.28	86.8	1.7
	CN10		12.2	1.89	18.7	77.6	0.29	87.4	1.6
H5-P2-C1	CN50	LCT 7+16	12.0	1.58	20.5	81.1	0.27	81.0	3.4
H5-P2-C2	CN53	LCT 10+17	12.1	1.59	20.5	69.7	0.21	78.8	4.3
H5-P2-C3	CN51	LCT 8+13	12.1	1.30	18.0	64.0	0.20 <sup>(2)</sup>	78.7	2.4
H5-P2-C4	CN54	LCT 11+18	11.5	1.33	17.1	86.9	0.23	83.8	2.2
H5-P2-C5	CN52	LCT 9+14	10.9	1.47	22.0	79.6	0.24	70.6	3.8
H5-P2-C6	CN55	LCT 12+15	11.9	1.85	21.0	85.2	0.28	77.7	3.6

<sup>(1)</sup> Recovery after 24 hours except for Phase 2 and Phase 1 trials referenced by this note.

<sup>(2)</sup> Tails grade changed from 0.1 g/t to 0.2 g/t as assaying error suspected.

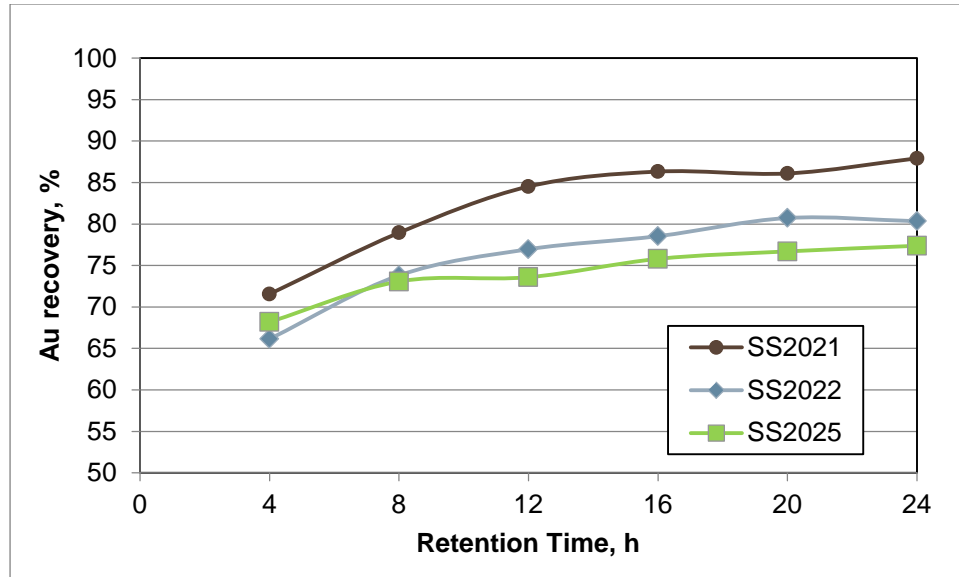

Figure 13-41: Au leaching kinetics for pyrite concentrate – FS Phase 1 (Tests CN7-18, CN42-49)

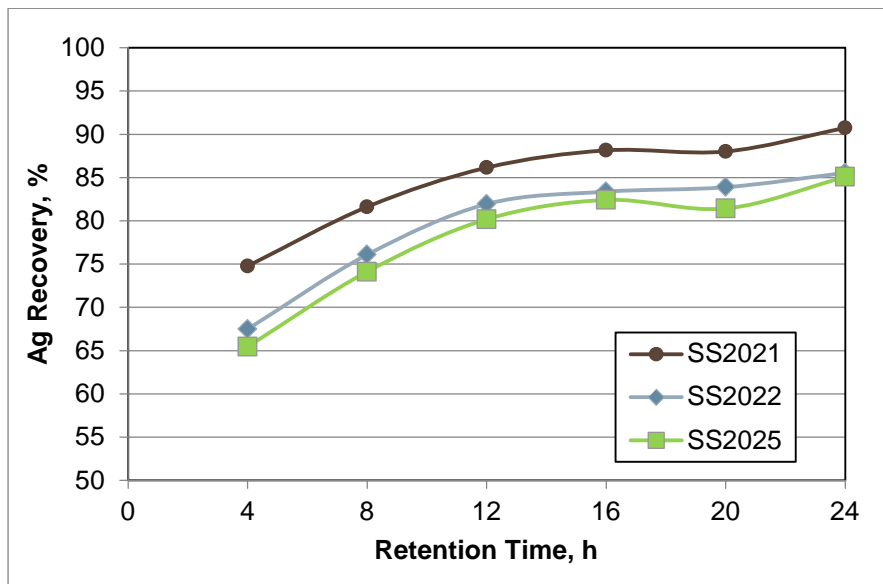

Figure 13-42: Ag leaching kinetics for pyrite concentrate – FS Phase 1 (Tests CN7-18, CN42-49)



The reagent consumptions and leaching kinetics were similar with those found during the PEA: after 8 hours of pre-oxidation, the concentrate leaching was mostly completed after 16 hours. For Phase 1 and the 24-hour leach trials, the average cyanide consumption was 2.05 kg/t NaCN while it was 18.0 kg/t for CaO. For Phase 2 and the 16-hour leach, the cyanide consumption was lowered to 1.5 kg/t whereas CaO consumption increased to 19.9 kg/t.

The overall gold extraction is sensitive to the regrind size, as illustrated by Figure 13-43. Silver extraction was relatively insensitive to regrind size in the tested range, as shown in Figure 13-44.

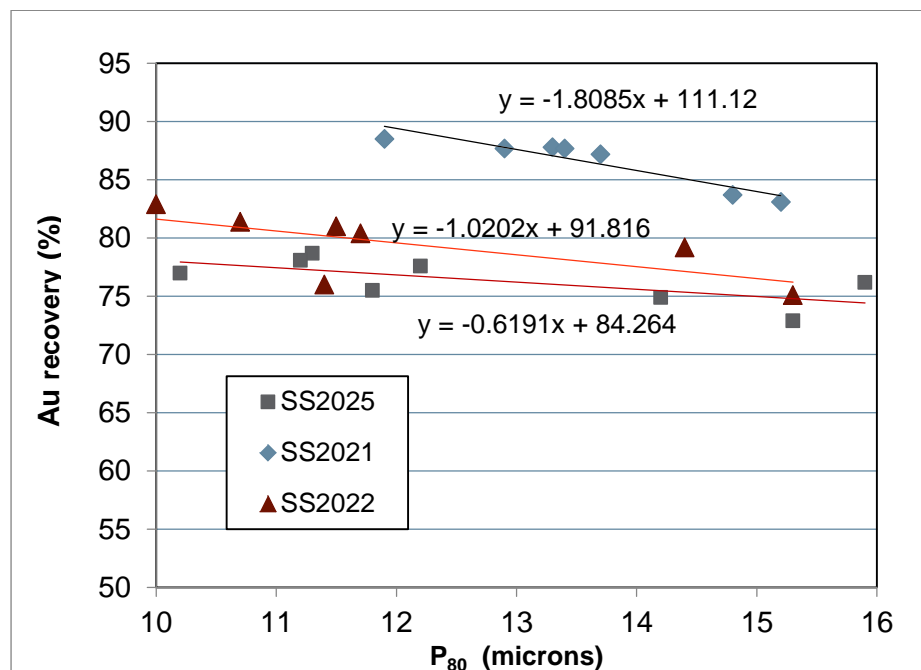

Figure 13-43: Effect of pyrite concentrate P<sub>80</sub> on Au leaching – FS Phase 1

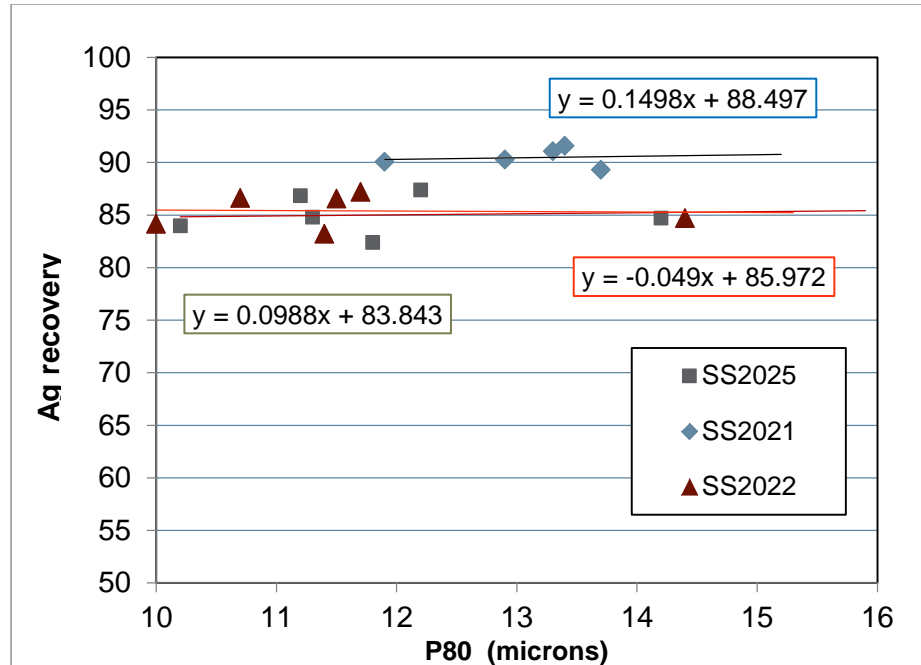

Figure 13-44: Effect of pyrite concentrate P<sub>80</sub> on Ag leaching – FS Phase 1

As shown in Figure 13-43, gold losses with coarser regrind size was between 0.6-1.8% per micron of P<sub>80</sub> achieved at the pyrite concentrate regrinding stage. Silver recovery was insensitive to regrinding intensity, within the tested range. A P<sub>80</sub> target of 12 µm is used for design purpose.

For metallurgical projection purpose, the silver recovery will be deemed as not varying with the regrinding P<sub>80</sub> while that for gold will vary by the median relationship displayed in Figure 13-42, with its expression as per Equation 13-19:

$$\text{Au rec to Py conc. leach circuit} = (12 - P_{80}) * 1.02 + [\text{Au rec @ 12 } \mu\text{m}] \quad [\text{Equation 13-19}]$$

After deducting the effect of the differential P<sub>80</sub> on the test results, the residual influence of the variations to the aeration conditions on the gold recovery is deemed insignificant. Nevertheless, the level of thiocyanate produced tended to increase through the use of incremental oxygen within the pre-oxidation environment and maintenance of higher dissolved oxygen level within the leaching stage.

The optimum conditions for leaching the Horne 5 pyrite concentrate, following completion of the Phase 2 testwork are:

- Regrinding the concentrate to 12  $\mu\text{m}$ ;
- Pre-oxidation for 7 hours with addition of oxygen to less than 1 mg/L of DO;
- Pre-oxidation lime addition of 10 kg/t;
- Leach residence time of 16 hours;
- NaCN addition to leach 1.0 g/L initially, allowed to decay below 0.7 g/L after 5 hours and 0.2 g/L thereafter;
- Addition of oxygen in the leaching leading to DO level of 5-7 ppm.

### Recovery Projections from Leaching of Pyrite Concentrate

The testwork data was analyzed to extract relationships from the leaching circuit feed characteristics that may be used to predict the eventual behaviour of the gold and silver recovery. Figure 13-45 and Figure 13-46 present the set of data for these two metals, respectively, as used for this analysis. For the concentrate, distinct trends showing results for a 16-hour and 24-hour leach are presented, as well as segregating the results for the optimized Phase 2 (“P2”) testwork. The data set for the pyrite concentrate excluded the data points generated with a feed  $P_{80}$  coarser than 13  $\mu\text{m}$ .

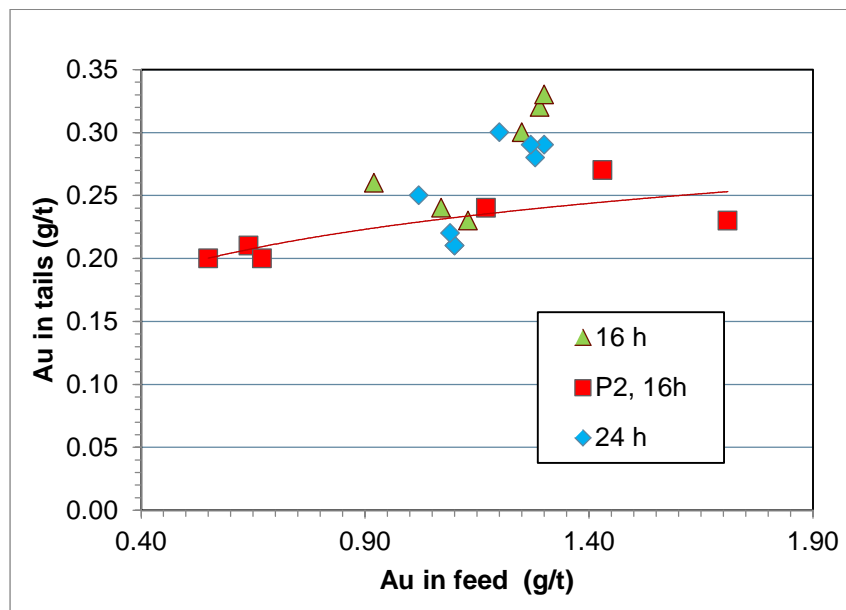

Figure 13-45: Au in pyrite conc. cyanidation tails vs Au in feed to circuit

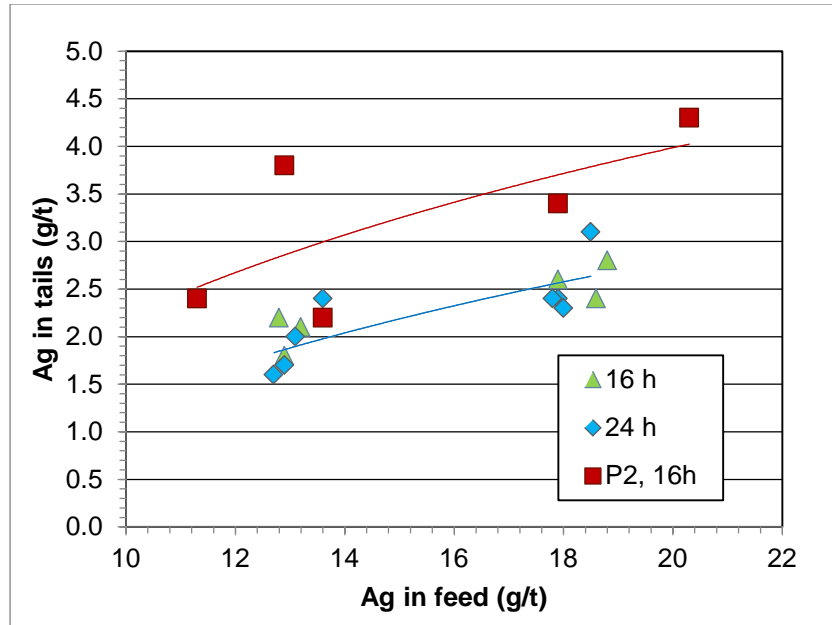

Figure 13-46: Ag in pyrite conc. cyanidation tails vs Ag in feed to circuit

Gold recovery under the optimized conditions implemented for the Phase 2 testwork provided did not show any deterioration from the 24h leach trials. As for silver, per Figure 13-46, an obvious degradation of the resulting recovery was seen, with two fairly parallel trends separating the results of Phase 1 and Phase 2 by the equivalent of about 1 g/t Ag in the leach tails. This outcome is likely more related to the operating conditions used in Phase 2 (oxidant type and flowrate) than the 16h of leach time used in Phase 2 since the trials of similar duration in Phase 1 were mostly following the response obtained for those at 24h, both for gold and silver.

The relationships shown in Figure 13-45 and Figure 13-46 (per Phase 2 red trend lines, for 16h leach duration) have the mathematical expressions provided by Equation 13-20 and Equation 13-21, respectively.

$$\text{Au tails to Py conc.} = 0.2309 + 0.0553 \times \ln([\text{g/t Au to Py conc. leach}]) \quad [\text{Equation 13-20}]$$

$$\text{Ag tails to Py conc.} = -3.8132 + 2.6176 \times \ln([\text{g/t Ag to Py conc. leach}]) \quad [\text{Equation 13-21}]$$

The potential for the adoption of reduced leach duration of 16h has been demonstrated with the Phase 2 trials since no gold losses are expected and the silver recovery degradation indicated in Figure 13-46 is compensated by a reduction of 0.5 kg/t in cyanide consumption, albeit with an incremental 1.5 kg/t of lime.

### 13.5.3 Pyrite Flotation Tailings Leaching Results

#### PEA Stage

The main test results from the PEA stage for leaching of the pyrite flotation tailings are presented in Table 13-29.

Table 13-29: Results for pyrite flotation tailings leaching tests

Comp.	Test	Float Test Product	Feed P80 (µm)	Reagent Consumption		Au Rec (%)	Tailings Grade Au (g/t)	Ag Rec (%)	Tailings Grade Ag (g/t)
				NaCN (kg/t)	CaO (kg/t)				
M1/M2	CN11	F24	71	0.34	0.48	75.3	0.04	-	-
	CN12	F24	69	0.04	1.09	74.7	0.04	-	-
MCA	CN18	+LCT1	-	0.12	0.87	79.0	0.03	97.7	<0.1
	CN19	LCT1	-	0.22	0.99	58.4	0.05	76.8	0.5
MCB	CN40	LCT2	52	0.26	0.37	78.1	0.04	72.9	-
	CN43	LCT2	52	0.18	0.49	79.1	0.04	94.3	<0.1
	CN44	LCT2	52	0.20	0.27	80.4	0.04	94.5	<0.1
	CN48	LCT2	52	0.15	0.40	80.5	0.04	74.8	0.6
	CN49	LCT2	52	0.15	0.40	75.6	0.05	73.2	0.6
	CN51	LCT2	52	0.12	0.36	79.4	0.04	76.7	<0.5
	CN55	LCT2	52	0.12	0.33	73.6	0.05	74.5	0.5
	CN56	LCT2	52	0.12	0.34	70.1	0.06	73.6	0.5

The results of the pyrite flotation tailings leach tests showed very consistent residue grades averaging 0.04 g/t Au regardless of the conditions. Silver recoveries varied from 73% to nearly 98%.

#### FS Stage – Phase 1 and Phase 2

Table 13-30 is presenting the results of the leach trials completed with the three composites used for the flotation testwork of the Phase 1 and the six involved in Phase 2.

The initial tests with each sample of Phase 1 were repeating the best conditions encountered at the end of the PEA while Phase 2 was carried out at fixed optimized conditions for the six variability samples involved. These conditions included the implementation of a slurry density of 55%, vs the 45% used in earlier tests. This modification was brought along as the rheology results indicated similar viscosity for both density targets.

Table 13-30: Results for pyrite tailings leaching tests – FS Phase 1 and Phase 2

Comp.	Test #	Flotation Test Product	Actual Grind Size (µm)	Reagent Consumption		Au Rec (%)	Tailings Grade Au (g/t)	Ag Rec (%)	Tailings Grade Ag (g/t)
				NaCN (kg/t)	CaO (kg/t)				
SS2021	CN21	LCT 3+4	51	0.11	0.29	71.5	0.08	71.5	0.5
	CN22		51	0.13	0.30	71.4	0.09	71.6	0.5
	CN28		51	0.10	0.19	71.6	0.08	n/a	n/a
SS2022	CN23	LCT 5+6	50	0.16	0.56	79.3	0.02	63.1	1.6
	CN24		50	0.20	0.64	83.4	0.02	62.0	1.6
	CN29		50	0.16	0.58	81.8	0.02	n/a	n/a
SS2025	CN19	LCT 1+2	46	0.18	0.38	79.2	0.02	79.2	0.6
	CN20		46	0.16	0.46	79.1	0.02	79.1	0.6
	CN27		46	0.12	0.43	79.3	0.02	n/a	n/a
H5-P2-C1	CN56	LCT 7+16	54	0.16	0.83	27.6	0.04	68.7	0.6
H5-P2-C2	CN57	LCT 10+17	55	0.23	1.89	64.5	0.04	45.7	1.6
H5-P2-C3	CN58	LCT 8+13	51	0.13	1.09	62.6	0.06	12.5	3.0
H5-P2-C4	CN59	LCT 11+18	52	0.12	1.27	60.9	0.03	66.2	< 0.5
H5-P2-C5	CN60	LCT 9+14	56	0.09	0.85	70.5	0.04	51.4	1.0
H5-P2-C6	CN61	LCT 12+15	52	0.13	0.91	72.8	0.04	66.7	< 0.5
H5-P2-C6	CN5	F20	56	0.18	0.38	74.0	0.04	Na	na
H5-P2-C6	CN6	F20	56	0.20	0.32	71.0	0.04	na	na

The reduction of the leaching duration from 12 to 8 hours applied for CN27 to CN29 did not alter the recovery achieved. More variable tailings grade were observed than for the PEA testwork.

The optimum conditions for leaching the Horne 5 pyrite flotation tailings, as adopted for the completion of the Phase 2 testwork, are:

- Leach residence time of 12 hours;
- NaCN addition to leach 0.15 g/L initially, allowed to decay below 0.10 g/L after 2 hours;
- pH of 10-5-11.0;
- Addition of oxygen in the leaching leading to DO level of 15 ppm.

The reduction of the leach duration from 12 to 8 hours, as touted during Phase 1, was not implemented for Phase 2 but may yet be a valid alternative.

### Recovery Projections from Leaching Pyrite Flotation Tailings

As with the pyrite concentrate leach circuit, the testwork data relevant to the pyrite flotation tailings was analyzed to extract relationships from the leaching circuit feed characteristics that may be used to predict the eventual behaviour of the gold and silver recovery. Figure 13-47 and Figure 13-48 present the Phase 1 (blue) and Phase 2 (red) data sets for these two metals, respectively, as used for this analysis.

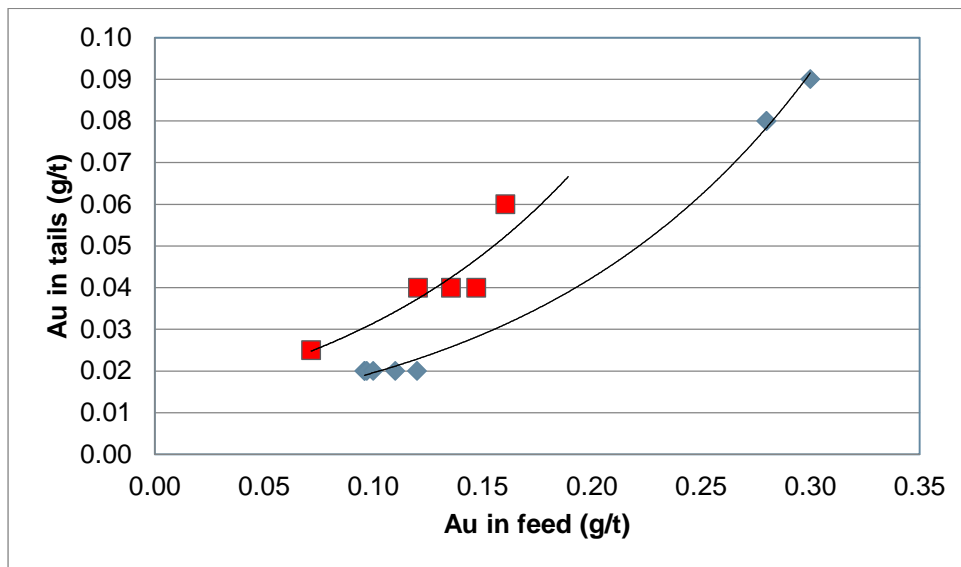

Figure 13-47: Au in pyrite tails leaching tails vs Au in feed to circuit

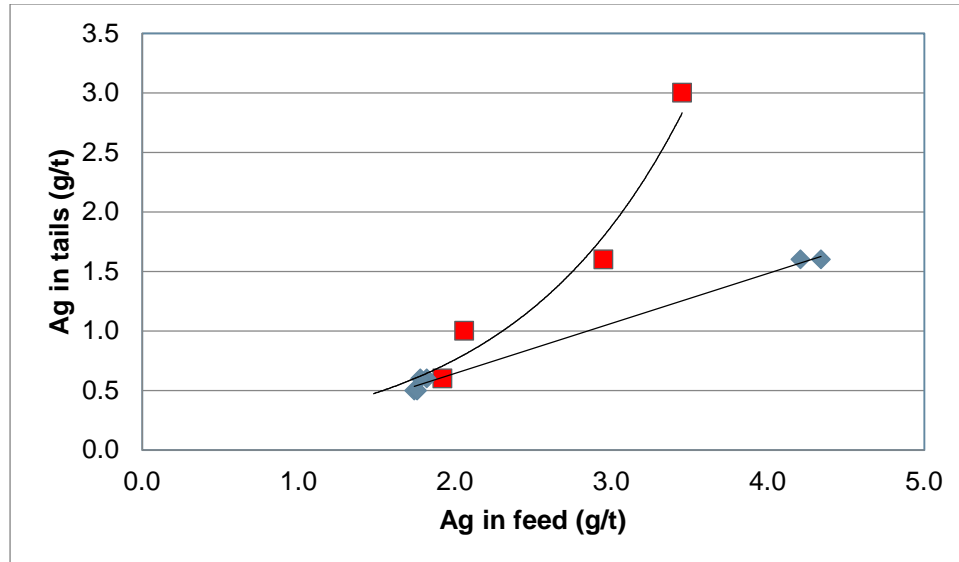

Figure 13-48: Ag in pyrite tails leaching tails vs Ag in feed to circuit

The relationships shown in Figure 13-47 and Figure 13-48 indicate a degradation of the results achieved in Phase 2. Relative to Phase 1, the leach condition modified between these two test programs mostly introduced a reduced availability of free cyanide in the solution, through an initial addition of 0.2 g/L used in Phase 1 and 0.15 g/L in Phase 2. This approach was pursued in expectation of a reduced cyanide consumption. Nevertheless, both set of tests indicated a similar NaCN consumption of 0.15 kg/t.

Adopting the better outlook from Phase 1 and related operating conditions for design purpose, the mathematical expressions for Phase 1 are provided by Equation 13-22 and Equation 13-23:

$$\text{Au tails to Py tails leach circuit} = 0.0091 \times e^{(7.7065 \times [\text{Au feed to Py tails leach}])} \quad [\text{Equation 13-22}]$$

$$\text{Ag tails to Py tails leach circuit} = 0.42 \times [\text{Ag feed to Py tails leach}] - 0.1955 \quad [\text{Equation 13-23}]$$



### 13.5.4 Fine Regrinding Testwork

The leaching test results performed on the pyrite concentrate demonstrates the sensitivity of the extraction yield with the regrind size, as illustrated by Figure 13-43 for the case of gold. The regrind size target is determined to be 12 µm and the regrind performance analysis is done considering such criteria.

During the PEA study, three Isa mill grinding signature tests were obtained from SGS using pyrite concentrate obtained from batch flotation tests. The resulting specific energies obtained to reach the target P<sub>80</sub> of 12 µm are very consistent at about 50 kWh/t, as illustrated in Figure 13-49.

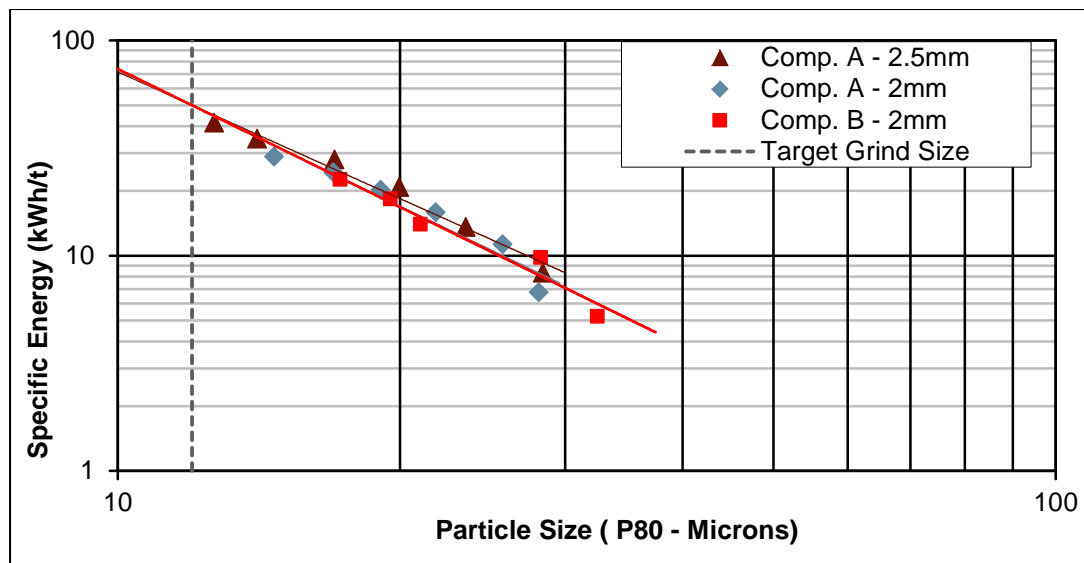

Figure 13-49: Isa mill signature curves with pyrite concentrate

The average of the three signature curves shown in Figure 13-49 follows the mathematical expression of Equation 13-24:

$$\text{Specific Energy (kWh/t of Pyrite conc.)} = 8555 \times [\text{P80}]^{-2.0633} \quad [\text{Equation 13-24}]$$

In order to compare the power requirements for fine regrinding of the pyrite concentrates using a different fine grinding technology, one sample from the PEA work and two samples from the Phase 1 of the FS program were shipped to Outotec in Finland for HIG mill (e.g. high intensity grinding mill) testing. The shipment included a blend of pyrite concentrates from various PEA batch flotation tests (to meet minimum weight requirement), a SS2021/SS2022 blend and SS2025 pyrite concentrates.

Figure 13-50 shows the signature curves for all three samples and compares these curves with the composite B Isa mill curve, from Figure 13-49. All the specific energy results fall within a range between 38 kWh/t and 48 kWh/t, with all the Isa mill curves being at the upper end of the range. Nevertheless, considering the accuracy of both tests, the Isa mill and the HIG mill are considered equivalent based on measured specific energy. The slope characterizing the curves demonstrates the high sensitivity of grinding energy to the regrinding product target size.

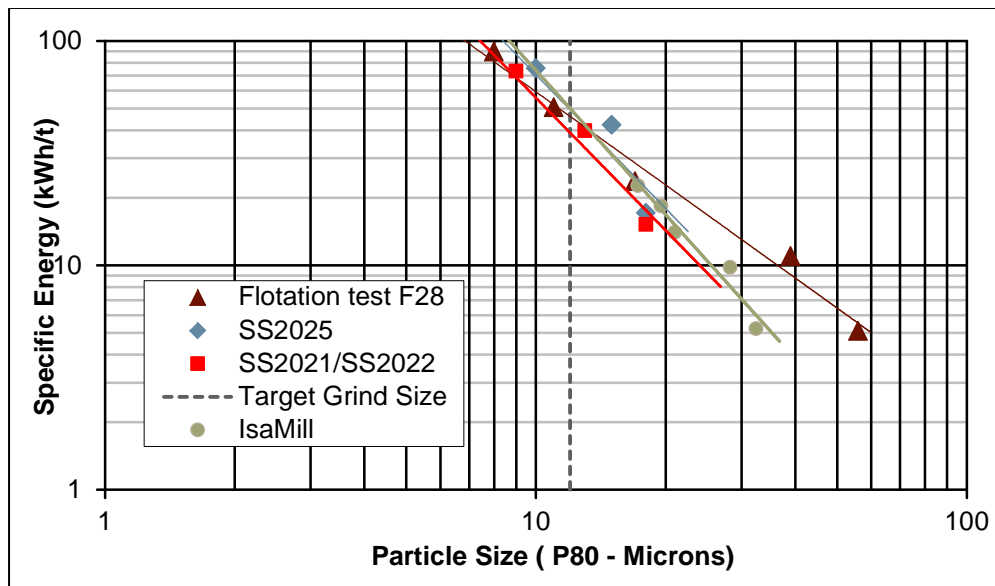

Figure 13-50: Comparison of HIG mill vs Isa mill signature curves

Considering the average of the three signature curves obtained for equipment sizing and product size vs tonnage of pyrite concentrate produced, Equation 13-25 is derived.

$$\text{Specific Energy (kWh/t of Pyrite conc.)} = 5364.2 \times [\text{P80}]^{-1.934} \quad [\text{Equation 13-25}]$$

Inversely, for a given installed regrinding power base and a given production of pyrite concentrate (based on sulphur head grade), Equation 13-24 allows to calculate the expected P<sub>80</sub> achieved by the industrial circuit. Equation 13-20 can then be used to readjust the recovery of gold otherwise expected from the use of Equation 13-19, based on a reground product with a P<sub>80</sub> of 12 µm.

### 13.5.5 Oxygen Uptake Tests

In order to determine the consumption of oxygen to the pre-oxidation and leaching circuits, oxygen uptake rate (“OUR”) tests have been completed by Air Liquide (Newark, Delaware) in a closed stirred reactor.

Both the pyrite flotation concentrate and tails were tested using samples from the bulk leaching of composite SS2025. Tests conditions were selected to reflect the optimized conditions derived from the previous bottle roll tests. Table 13-31 and Table 13-32 describe those conditions for the concentrate and tailings, respectively.

**Table 13-31: Oxygen uptake rate test conditions for reground bulk Py conc. SS2025**

Parameter	Pre-oxidation Conditions	Leaching Conditions
Temperature (°C)	35	35
Slurry density (%w/w solids)	35	35
pH	10.5 (10 kg/t CaO addition at onset, none after for Test 4)	11-11.5
Dissolved oxygen (ppm)	Maintained <1 ppm by adjusting O <sub>2</sub> flows	Maintained between 12-15 ppm by adjusting O <sub>2</sub> flows
Time (h)	8	24
Cyanide addition (g/L)	-	Initial addition = 1.2 g/L CN Maintain 850 ppm CN for 2 hours, allow to drift, but not below 200 ppm residual CN

**Table 13-32: Oxygen uptake rate test conditions for SS2025 bulk Py flotation tails**

Parameter	Leaching Conditions
Temperature (°C)	25
Slurry density (%w/w solids)	45
pH	10-10.5
Dissolved oxygen (ppm)	15
Time (h)	12
Cyanide addition	Initial addition = 300 ppm, maintain for 5 hours; at 100 ppm CN from 5 to 12 hours. Final solution should target ~75 ppm CN

With the initial sample of pyrite concentrate displaying a pH of 3.1 upon reception at Air Liquide laboratories, concerns were raised as to whether the sulphides were sufficiently active to have started to oxidize while in transit. This original sample was tested nevertheless (as Conc3 and Conc4) but another one was dispatched to Air Liquide from SGS. The test conditions were then modified (per Conc5 and Conc6 trials) to limit the dissolved oxygen level at between 3-5 ppm, instead of targeting 12-15 ppm as earlier.

The instructions regarding cyanide levels were actually targeting NaCN, not CN levels as understood by Air Liquide. Air Liquide therefore added much more cyanide as what was used in the SGS testwork program. On this basis, the resulting cyanide consumption and level of contaminants in the resulting leach tails slurry were not considered for analysis. Nevertheless, the OUR values are relevant for the purpose sought, which is to evaluate the consumption of oxygen in the industrial plant.

Including the scale-up effects on the oxygen transfer efficiency, Air Liquide calculated the equivalent consumption of oxygen used in the pre-oxidation and cyanidation (“CNL”) stages as presented in Table 13-33.

**Table 13-33: Oxygen consumption for pre-oxidation and leaching circuits, per Air Liquide**

Test	Sample	Initial pH	DO –	Pre-Ox	Leach	Total
			PreOx/Leach			
			(.mg/L)	(kg O <sub>2</sub> consumed per t of solid)		
1	Conc3	3.1	1 / 15	1.43	1.44	2.87
2	Conc4	3.1	1 / 15	1.28	1.72	3.00
3	Conc5	8.0	1 / 4	0.75	0.22	0.97
4	Conc6	8.0	1 / 4	0.52	0.13	0.65
5	TAIL1		na / 15	na	0.82	0.82
6	TAIL2		na / 15	na	0.65	0.65

### 13.6 Cyanide Destruction Testwork

During the PEA study, batch cyanide destruction (“CND”) testwork using the INCO SO<sub>2</sub>/air technology was undertaken on the residues of the bulk cyanidation products of both the pyrite flotation concentrate and tailings. The pyrite flotation concentrate was tested at 35% and 60% (w/w) solids, while the tailings were tested at 45% and 60% (w/w). All these preliminary tests were done at SGS Lakefield.

The tests were conducted by adding sulphur dioxide (as sodium metabisulphite, Na<sub>2</sub>S<sub>2</sub>O<sub>5</sub>), copper sulphate (as CuSO<sub>4</sub>.5H<sub>2</sub>O) and lime to maintain a target pH of 8.5. A residual concentration of less than 1 ppm weak-acid dissociable cyanide (“CN<sub>WAD</sub>”) was targeted and

achieved in all tests. The CND1-4 batch tests were conducted to demonstrate that this result was readily achievable using the standard SO<sub>2</sub>/air process. The reagent consumption values presented in Table 13-34 are not representative of an optimized process since obtained from batch instead of dynamic tests.

**Table 13-34: PEA results of cyanide destruction tests with the INCO SO<sub>2</sub>/air technology**

Test Product	Test	pH	Solution Assay (mg/L)				Reagent Addition					
			CN <sub>T</sub>	CN <sub>WAD</sub>	Cu	Fe	g/g CN <sub>WAD</sub>			kg/t solids		
							SO <sub>2</sub>	Lime	Cu	SO <sub>2</sub>	Lime	Cu
CN39	Feed	9.8	141	141	130	0.6	-	-	-	-	-	-
	CND1	8.5	0.66	0.86	2.5	0.4	14.65	2.44	0.14	3.84	0.64	0.04
	CND2	8.6	1.70	0.26	1.5	1.0	16.63	1.67	0.14	1.56	0.16	0.01
CN40	Feed	10.3	166	166	30.3	0.4	-	-	-	-	-	-
	CND3	8.5	0.02	1.02	0.5	0.1	16.63	5.47	0.24	3.37	1.11	0.05
	CND4	8.5	0.64	<0.1	<0.1	0.8	14.25	5.50	0.24	1.58	0.61	0.03

It should be noted that while the CND tests were successful at 60% (w/w) solids for both the pyrite concentrate and pyrite flotation tailings products, the testwork report noted that the slurries were quite viscous and proper air dispersion was limited. Subsequent slurry rheology testing was to be used to determine the optimum density to be used.

At the onset of the FS, the design criteria for the treated slurries were modified, targeting higher residual levels of CN<sub>wad</sub>. Since these would be achievable using Caro's acid (H<sub>2</sub>SO<sub>5</sub>), as well as the SO<sub>2</sub>/air approach, continuous CND tests were commissioned at the Cyanco facilities (Piscataway, New Jersey), the holder of patents for Caro's acid generator design.

The objectives of the test program were to compare Caro's acid technology versus SO<sub>2</sub>/air at different slurry densities while establishing optimum operating conditions to assess the related operating costs of each approach.

Samples of reground pyrite flotation concentrate and of pyrite flotation tails from bulk flotation tests SS2025 were sent to Cyanco for testing. Using those samples, Cyanco completed the pre-oxidation and leaching stages following process conditions representative of the on-going trials at SGS, so as to generate fresh slurry samples to be submitted to CND testing.

Table 13-35 and Table 13-36 summarize these conditions. For pyrite concentrate leaching, two different levels of dissolved oxygen were tested to take into consideration the impact of thiocyanate formation during leaching on the cyanide detoxification. Only one set of parameters was used for pyrite flotation tails leaching.

**Table 13-35: Pre-oxidation and leaching conditions of reground pyrite conc.**

Conditions	Pre-oxidation	Leaching	
Temperature (°C)	35	35	
Slurry density (%w/w solids)	35	35	
pH	11 kg CaO addition/ kg ore	11-11.5	
Dissolved oxygen (ppm)	Maintained below 1ppm by adjusting air flow	15 ppm by adjusting O <sub>2</sub> flow	3 to 5ppm by adjusting O <sub>2</sub> flow
Time (h)	8	24	
NaCN addition	-	Initial addition = 2.5-2.6 kg/t (1 g/L NaCN) Maintain NaCN = 0.7 g/L for 5 hours, allow to drift, but not below 200 ppm.	
Au/Ag extraction	-	CIP circuit @ 50 g/L C for 4 hours	

**Table 13-36: Leaching conditions of SS2025 bulk pyrite flotation tails**

Conditions	Leaching
Temperature (°C)	25
Slurry density (%w/w solids)	45
pH	10-10.5
Dissolved oxygen (ppm)	10 ppm by adjusting O <sub>2</sub> flow
Time (h)	12
CN addition	Initial addition = 0.2 kg/t, Maintain at ~0.1 g/L for 5 hours, allow to drift. Final solution should target ~75 ppm CN.
Au/Ag extraction	CIP circuit @ 50 g/L for 1 hour

After leaching and carbon absorption, the slurry was settled and re-slurried to the target solid concentration. The free cyanide level was also adjusted with NaCN prior to detoxification test to simulate the real plant operating conditions.

Considering different aspects of Horne 5 Project, the target for post-treatment total cyanide concentration (“CN<sub>T</sub>”) was defined by Falco for the FS as a maximum of 10 ppm, with a level of 5 ppm deemed sufficient to prevent peaks above the maximum sought.

For the pyrite concentrate, three process schemes were tested: SO<sub>2</sub>/O<sub>2</sub>, one stage Caro’s acid and two-stage Caro’s acid. The first one involves bubbling of SO<sub>2</sub> and O<sub>2</sub> in the reactor at pH 8 to 9 and addition of lime and copper sulphate. The one stage Caro’s acid consists of an oxidation of cyanide ions with a blend of hydrogen peroxide and sulphuric acid, at pH 8 to 9, under various ratios of the two reagents. Finally, the two-stage Caro’s acid adds a second step of acidification with sulfuric acid to target residual levels of ferrocyanates.

Table 13-37 presents the various conditions used for cyanide destruction. Reagent additions and retention times varied for each test conditions until obtaining the optimal point for each process.

Table 13-37: Cyanide destruction test conditions

Conditions	Reground Pyrite Conc.	Pyrite Tails
Process	SO <sub>2</sub> /O <sub>2</sub> 1 stage Caro's acid 2 stages Caro's acid	SO <sub>2</sub> /O <sub>2</sub> 1 stage Caro's acid
Temperature (°C)	35	Ambient
Slurry density (%w/w solids)	47; 55; 60	55; 60
Initial pH	12	10.5
Free final CN level (ppm)	100	200

Trials made at slurry densities of 60% and 55% with pyrite concentrate confirmed the concerns reported at PEA level about the resulting high viscosity: proper destruction of cyanide is not possible at such density. At 47% solids, both Caro's acid and SO<sub>2</sub>/O<sub>2</sub> are able to reach CN<sub>T</sub> below the target concentration. Thiocyanate assays were not available for those tests. For one stage and 2 stages Caro's acid treatment, no copper sulphate is needed, nor aeration. Table 13-38 summarizes the results for CND tests on the reground pyrite flotation concentrate.

Table 13-38: Reground pyrite flotation concentrate CND test results

Process	Final CN <sub>T</sub> (ppm)	pH	Retention time (h)	SO <sub>2</sub> (g / g CNWAD)	H <sub>2</sub> O <sub>2</sub> (g / g CNWAD)	H <sub>2</sub> SO <sub>4</sub> (g / g CNWAD)	Ca(OH) <sub>2</sub> (g / g CNWAD)	Cu <sup>2+</sup> (ppm)
1 Stage Caro's acid	6.33	9	0.5	n/a	1.96	10.67	9.59	0
2 Stages Caro's acid	8.92	8	0.5+0.5	n/a	1.96	7.11 stage1 3.81 stage 2	8.44	0
SO <sub>2</sub> /O <sub>2</sub>	9.93	8	2	5.0	n/a	n/a	2.97	50

Trials with pyrite flotation tails show similar results at both slurry densities tested. CN<sub>T</sub> levels reached values well below the target concentration (10 ppm). Table 13-39 presents the results for CND tests with the pyrite flotation tails.

Table 13-39: Pyrite flotation tails CND test results

Process	% Solids	Final CN <sub>T</sub> (ppm)	pH	Retention time (h)	SO <sub>2</sub> (g/g CN <sub>WAD</sub> )	H <sub>2</sub> O <sub>2</sub> (g/g CN <sub>WAD</sub> )	H <sub>2</sub> SO <sub>4</sub> (g/g CN <sub>WAD</sub> )	Ca(OH) <sub>2</sub> (g/g CN <sub>WAD</sub> )	Cu <sup>2+</sup> (ppm)
1 Stage Caro's acid	55	2.37	9	0.5	n/a	1.96	10.67	8.37	0
1 Stage Caro's acid	60	2.57	9	0.5	n/a	1.97	10.67	9.88	0
SO <sub>2</sub> /O <sub>2</sub>	55	2.71	8.5	2	4.0	n/a	n/a	2.1	25
SO <sub>2</sub> /O <sub>2</sub>	60	3.53	8.5	2	4.0	n/a	n/a	2.41	0



### 13.7 Thickening, Filtration and Rheology Testwork

A series of thickening, filtration and rheology tests was performed by Pocock Industrials, Inc. (“Pocock”), of Salt Lake City, Utah. These tests provided the parameters for proper thickener, filter, and pumps’ and agitators’ motors sizing. Six products were sent to the test laboratory, all provided from composited samples obtained from bulk flotation and leaching tests. Table 13-40 describes the tests performed and the source of the tested samples.

**Table 13-40: List of tested materials vs sample sources for thickening, filtration and slurry rheology**

Tested Material	Sample
Cu Concentrate	Blend of SS2021, SS2022 and SS2025
Zn Concentrate	Blend of SS2021, SS2022 and SS2025
Pyrite Concentrate	SS2025
Pyrite Tailings	SS2025
Reground and Leached Pyrite Concentrate	SS2025
Leached Pyrite Tailings	SS2025

#### 13.7.1 Thickening

Thickening tests were conducted as both static and dynamic tests, the latter negating the requirement for scale-up factors required to interpret static tests but with information obtained from the static test nevertheless considered to set limits to the expected scaled-up performance of the thickener.)

Results of the dynamic thickening tests are summarized in Table 13-41. After an initial flocculant screening stage, all the tests were done with an anionic polyacrylamide flocculant, with 15% charge and medium to high molecular weight (SNF AN 910 SH). The resulting total solids in suspension (“TSS”) levels were all ranging between 150 ppm to 250 ppm.

Table 13-41: Thickening test results

Product tested	High rate thickener		High density thickener		Paste thickener		Flocculant dosage
	Loading (m <sup>3</sup> /m <sup>2</sup> h)	UF density (%solids)	Loading (m <sup>3</sup> /m <sup>2</sup> h)	UF density (%solids)	Loading (m <sup>3</sup> /m <sup>2</sup> h)	UF density (%solids)	(g/t)
Cu Concentrate	2.87	78	2.14	79	n/a	n/a	10-15
Zn Concentrate	3.29	71.5	2.2	72.5	n/a	n/a	15-20
Pyrite Concentrate	3.78	74.5	3.29	75.5	n/a	n/a	20-25
Reground and Leached Pyrite Concentrate	3.33	46	2.66	50	4.25	53	45-50
Pyrite Tailings	2.89	65.5	1.85	66.5	3.82	68	25-30
Leached Pyrite Tailings	3.1	63.5	2.62	65.5	3.98	67	15-20

Table 13-41 indicates that high rate thickening achieves similar underflow (“UF”) densities than high density and paste thickening, with the reground pyrite concentrate obtaining marginally better underflow density increment.

A general observation from the laboratory work is that there is a tendency for all materials tested to over-thicken very quickly, reaching viscosities beyond the ability of any rake mechanism to handle: the materials, especially the fine pyrite concentrate, turn into a concrete-like sludge, making it very difficult to handle.

For all the duties within the plant, the indicated densities reachable with a high-rate thickener are above the targeted values by the processes. The only exception resides with the reground pyrite concentrate for which the improved density using a paste thickener (or high-compression unit) is to be sought to reach a density appropriate for feeding the paste plant filters.

### 13.7.2 Concentrate Filtration

Pocock tested the copper and zinc concentrates with an apparatus and under procedures yielding insight into the sizing of pressure filters applicable for these materials. Table 13-42 to Table 13-44 indicate the parameters obtained from this exercise.

Table 13-42: Pressure filtration sizing parameters from testwork

Material	Feed Solids Conc.	Sizing Basis (dry m <sup>3</sup> /t) <sup>(1)</sup>	Cake Thickness (mm)	Design Cake Moisture <sup>(2)</sup>	Total Cycle Time <sup>(3)</sup> (min)	Volumetric Production Rate <sup>(4)</sup> (tpd/m <sup>3</sup> )	Area Basis Production Rate <sup>(4)</sup> (tpd/m <sup>2</sup> )
Thickened Copper Concentrate	72.5	0.531	50	9.7%	9.0	251.2	5.48
Thickened Zinc Concentrate	70.8	0.585	50	8.7%	9.0	227.9	4.97

Note: Refer to notes 1 to 4 in Table 13-43 below.

Table 13-43: Pressure filtration sizing data for copper concentrate samples

General Pressure Filter Design Criteria		Unit
Material	Thickened Copper Concentrate	--
Filter Feed Solids	72.5	% (nominal)
Cloth	8 – 10 Mono – Multifilament Polypropylene	cfm/ft <sup>2</sup>
pH	10.85	unit
Feed Temperature	20	°C
Feed Pressure	551.7	kPa
Cake Thickness	50	mm (full cake)
Dry Cake Weight	117.76	dry kg/m <sup>2</sup> (@ 50 mm thickness)
Dry Bulk Density	2,355.2	dry kg/m <sup>3</sup>
Cake Moisture	9.7	%
Wet Bulk Density	2,608.44	kg/m <sup>3</sup> (@ 9.7% moisture)
Sizing Basis <sup>(1)</sup>	0.531	m <sup>3</sup> /t
Elements of Automatic Recessed Plate Pressure Filter Cycle Time		
Minimum Cake Form Time <sup>(2)</sup>	2.00	minute
Theoretical Form Time	0.40	minute (half cake)
Initial Full Time	2.00	minute
Air Blow Time	3.00	minute (total)
Dry Time/W	0.025	
Resulting Cake Moisture	9.7	%
Miscellaneous Time <sup>(3)</sup>	4.00	minute
Minimum Cycle Time <sup>(4)</sup>	9.00	minute
Number of Cycles per 20-hour Operating Day	<b>133.33</b>	<b>Cycle</b>

(1) Sizing basis in m<sup>3</sup> of pressure filter volume per tpd of dry solids. Includes a 1.25 scale-up factor.

(2) Form Time shown is for 25 mm (half) cake thickness due to the dual filtration surface.

(3) Miscellaneous Time of 4 minutes for cake discharge and cloth washing time.

(4) Cycle Time will vary with varying pumping and miscellaneous times selected. Minimum Fill Time for the Form Cycle is 2.00 minutes. Similarly, the minimum Fill Time for the Wash Cycle is 1.00 minutes and the minimum Dry Time is 1.00 minute.

Table 13-44: Pressure filtration sizing data for zinc concentrate

General Pressure Filter Design Criteria		Unit
Material	Thickened Zinc Concentrate	--
Filter Feed Solids	70.8	% (nominal)
Cloth	8 – 10 Mono – Multifilament Polypropylene	cfm/ft <sup>2</sup>
pH	11.38	unit
Feed Temperature	20	°C
Feed Pressure	551.7	kPa
Cake Thickness	50	mm (full cake)
Dry Cake Weight	106.84	dry kg/m <sup>2</sup> (@ 50 mm thickness)
Dry Bulk Density	2,136.7	dry kg/m <sup>3</sup>
Cake Moisture	8.7	%
Wet Bulk Density	2,339.83	kg/m <sup>3</sup> (@ 8.7% moisture)
Sizing Basis <sup>(1)</sup>	0.585	m <sup>3</sup> /t
Elements of Automatic Recessed Plate Pressure Filter Cycle Time		
Minimum Cake Form Time <sup>(2)</sup>	2.00	minute
Theoretical Form Time	0.26	minute (half cake)
Initial Full Time	2.00	minute
Air Blow Time	3.00	minute (total)
Dry Time/W	0.028	
Resulting Cake Moisture	8.7	%
Miscellaneous Time <sup>(3)</sup>	4.00	minute
Minimum Cycle Time <sup>(4)</sup>	9.00	minute
Number of Cycles per 20-hour Operating Day	<b>133.33</b>	<b>Cycle</b>

(1) Sizing basis in m<sup>3</sup> of pressure filter volume per tpd of dry solids. Includes a 1.25 scale-up factor.

(2) Form Time shown is for 25 mm (half) cake thickness due to the dual filtration surface.

(3) Miscellaneous Time of 4 minutes for cake discharge and cloth washing time.

(4) Cycle Time will vary with varying pumping and miscellaneous times selected. Minimum Fill Time for the Form Cycle is 2.00 minutes. Similarly, the minimum Fill Time for the Wash Cycle is 1.00 minutes and the minimum Dry Time is 1.00 minute.

The indicated cycle time breakdown shown in Table 13-43 and Table 13-44 are hypothetical and include various assumptions that may or may not be applicable to the selected filter type. Gradual blinding of the filter cloth would also require to gradually lengthen the drying time in order to maintain the targeted cake moisture.

### 13.7.3 Slurry Rheology

The slurry rheology was assessed using Fann and Haake (for paste-range) viscometers to establish the link between spindle speed (shear rate) and slurry density to apparent viscosity. The relationship between shear stress and shear rate also enables to get the yield value over the range of solids content of interest.

Figure 13-53 to Figure 13-56 are showing data relevant for the sizing of the thickener rake mechanism torque rating, the agitator torque and motor power requirement and the thickener underflow pump and other transfer pumps operating at the higher range of densities represented therein.

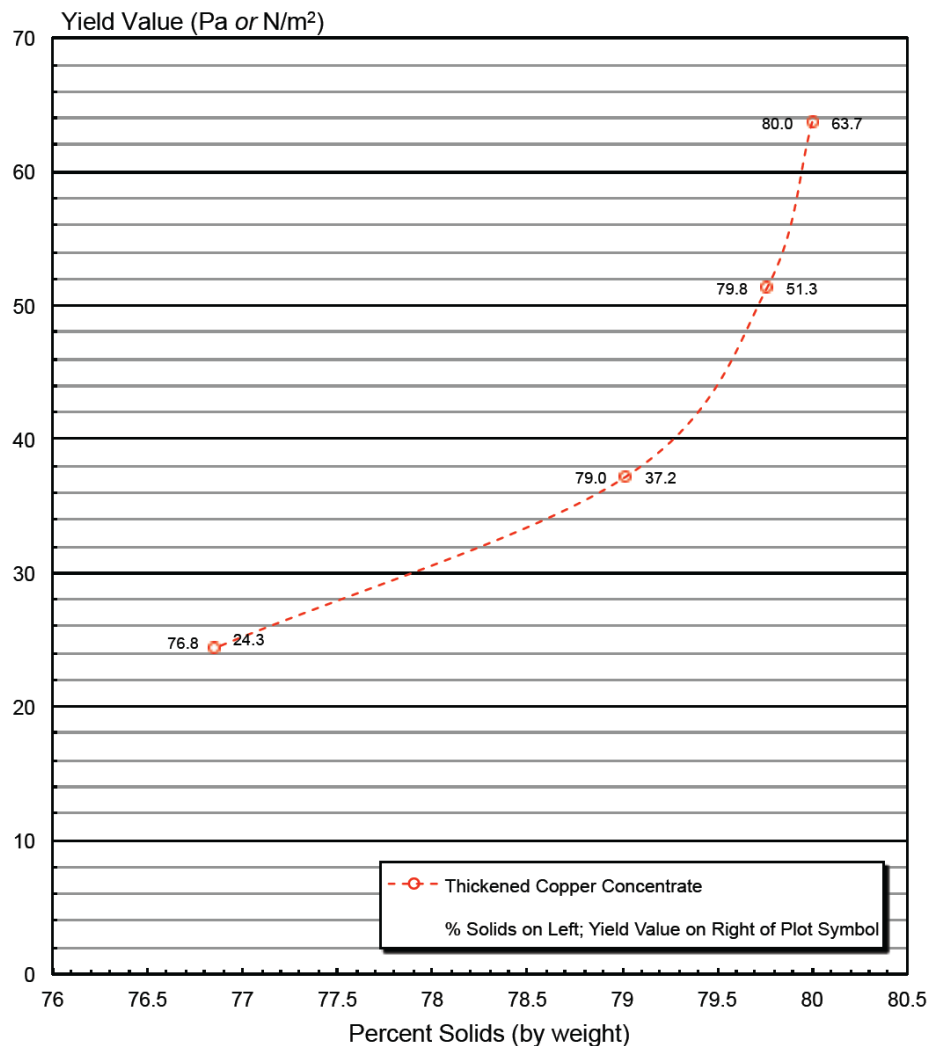

Figure 13-51: Yield stress vs slurry density for copper concentrate

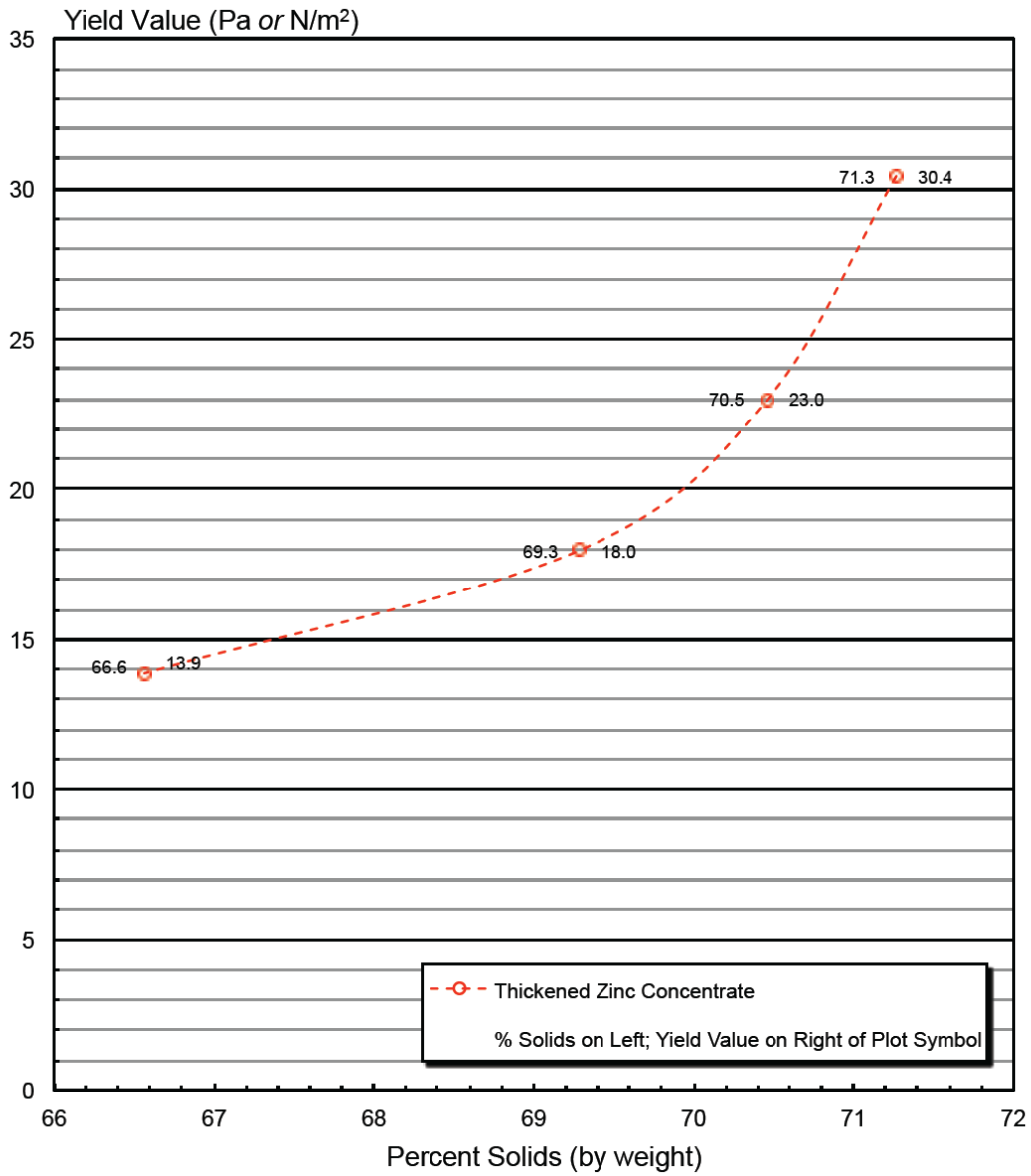

Figure 13-52: Yield stress vs slurry density for zinc concentrate

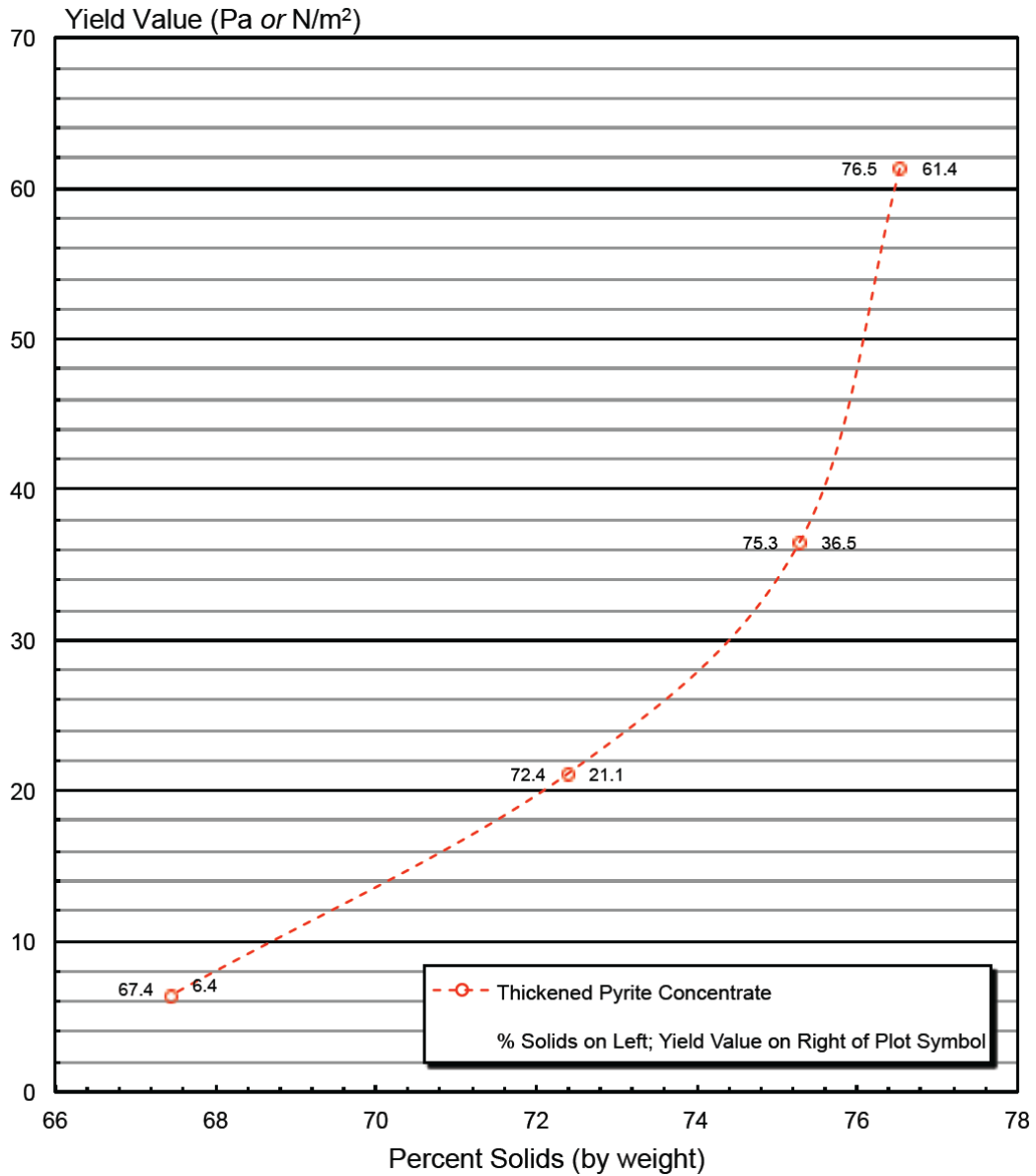

Figure 13-53: Yield stress vs slurry density for pyrite concentrate

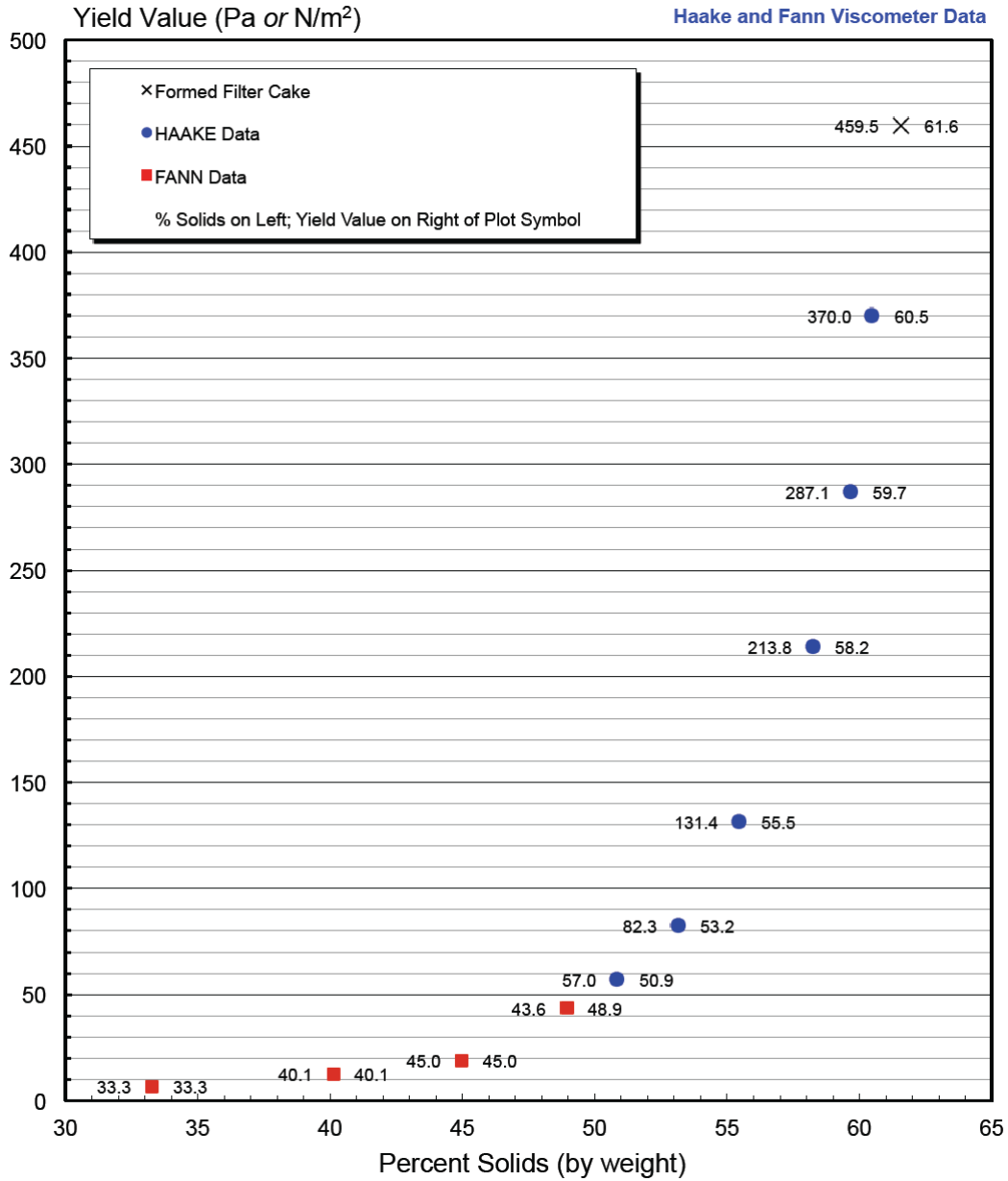

Figure 13-54: Yield stress vs slurry density for reground pyrite concentrate



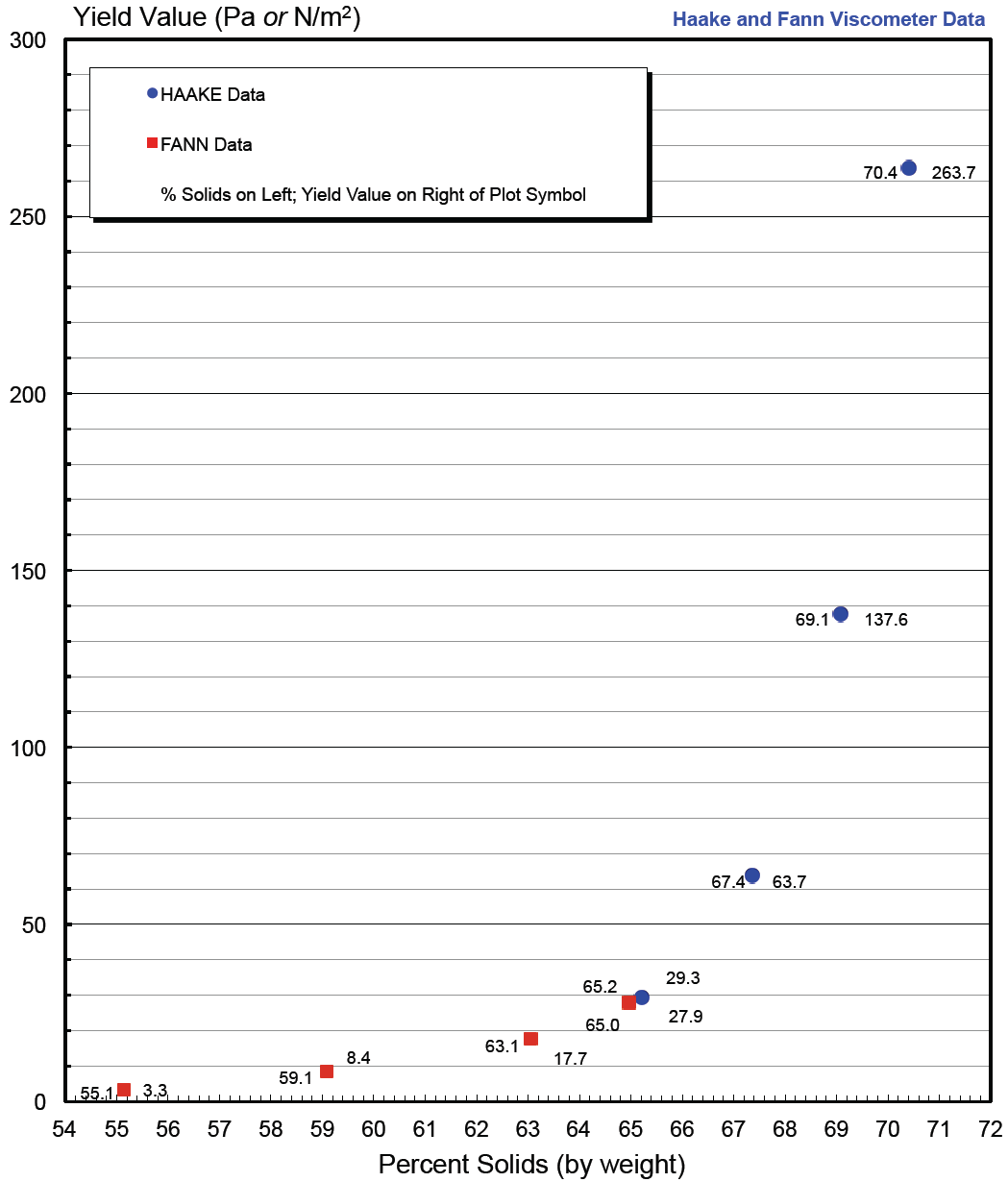

Figure 13-55: Yield stress vs slurry density for pyrite tailings

## 13.8 Paste Backfill Filtration Testing

Filtration testing was essential to determine the most efficient and reliable filtration technology to be used in the paste backfill plant. Filtration was required to dewater a combined 50/50 ratio of PCT and PFT from 49.7% solids to 83% solids by weight. The dewatered tailings were then combined with a binder mix of slag and cement as well as water in order to produce a consistent paste at 76.3% solids to be sent to the mine underground. Refer to Section 16.8 for the paste backfill plant process description.

### 13.8.1 Filtration Testing by Golder

Preliminary testing was done by Golder in order to establish whether or not vacuum filtration should be considered in the paste backfill plant design basis. Pressure filtration was also tested. This was essential in order to confirm the filtration performance at several combined ratios of the PFT and the PCT feeding the paste backfill plant. The results proved to be favorable towards pressure filtration with poor filtration performance obtained through vacuum filtration. A filtration rate of 108 kg/m<sup>2</sup>h and a cycle time of 17.5 minutes were used as conservative parameters for the preliminary design of the paste backfill plant filters. Refer to Section 16.8.2 for details on these preliminary filtration tests.

### 13.8.2 Filtration Testing by Suppliers

Subsequent filtration tests were conducted by Outotec and AqSepTence Group (formerly known as Diemme) to further optimize filtration parameters used in the paste backfill design basis and confirm the elimination of vacuum filtration as a potential technology. Outotec was responsible for tests using filter presses and vacuum disk filters whereas AqSepTence Group focused on filter press testing.

Testing was performed on two tailings samples provided by Cyanco laboratories. The two samples consisted of a 50/50 blend of PFT and PCT as well as a 100% sample PFT. The latter was tested to predict the filtration behaviour of the PFT in the event that a dry-stack type of tailings plant was an elected option for PFT management.

Based on the filtration results obtained by both suppliers, pressure filters were confirmed as the optimal technology to achieve required cake moisture content of 17% w/w. A filtration rate of 180 kg/m<sup>2</sup>h and a cycle time of 13.5 minutes were selected as optimized design parameters for the filtration process design.

It is important to note that the testing results did not include filtration inefficiency factors such as filter cloth blinding or tearing. The results reported are as recorded by the laboratory technician. While some filter cloth blinding is expected in any kind of filter design, the lab test results assumed that the filter cloths were replaced prior to or when any significant impact on filter performance is recorded or observed.

### 13.8.2.1 Filtration Testing by Outotec

Tests were conducted with Outotec’s Larox 100 test unit for the 50/50 PFT/PCT and the 100% PFT samples in order to determine the suitability of pressure filtration technology. Bench scale testing was conducted to evaluate filter cake thickness, filtration rate and cake moisture content. All tests were conducted using the following process parameters:

- 45 mm filter chamber;
- ASKO T50 filter media;
- 6 bar pumping pressure;
- 11 bar pressing pressure;
- 7 bar air dry pressure.

The test results are summarized in Table 13-45.

Table 13-45: Lab pressure filtration results

Parameters	Units	50/50 PFT/PCT		100% PFT	
Feed Density	wt%	53.5	60	50	55
Filtration Rate	kg/m <sup>2</sup> h	240 – 284	252 – 266	201 – 224	226 – 239
Filter Cake Moisture	wt%	14 – 17	14 – 15	13 – 15	14 – 15
Filter Cake Thickness	mm	43 – 45	44 – 45	44 – 45	44

The specified moisture target of less than 17% w/w was achieved using pressure filtration technology. For the 50/50 PFT/PCT sample, the filtration rate to produce a 15% moisture filter cake with a solids feed density of 55% was 240 kg/m<sup>2</sup>h. The filtration rate increased to 266 kg/m<sup>2</sup>h when the feed density was increased to 60%. Figure 13-56 shows the 50/50 PFT/PCT pressure filter dewatered cake and the filtrate.



Figure 13-56: 50/50 PFT/PCT pressure filter cake (left) and filtrate (right)

Tests were also conducted with Outotec’s Scammec unit to determine the sustainability of vacuum filtration technology for the 50/50 PFT/PCT sample. The test results are summarized in Table 13-46.

Table 13-46: Vacuum filtration results

Feed Density (wt%)	Cycle Time (sec)	Cake Thickness (mm)	Cake Moisture (wt%)	Filtration Rate (kg/m <sup>2</sup> h)
61	86	3	21	352
	60	3	22	450
	48	3	22	530
	40	3	23	551
54	86	4	22	296
	60	3	23	351
	48	3	22	407
	40	3	23	454

The moisture target of less than 17% w/w was not achieved in all test runs. The filter cakes were also very thin, measuring at 3 mm. Figure 13-57 shows the 50/50 PFT/PCT filter cakes at 53.5% w/w solids in the slurry feed and 60% w/w. This proves that vacuum filtration is not a viable filtration technology to meet the paste backfill plant process requirements.



Figure 13-57: 50/50 PFT/PCT vacuum filtration cakes – 53.5% w/w slurry feed (left) and 60% w/w (right)

### 13.8.2.2 Filtration Testing by AqSepTence Group

The filtration tests were carried out for the 50/50 PFT/PCT and the 100% PFT samples using a bench scale pilot plant that simulates the formation of a single cake with a filtration surface area of 0.0077 m<sup>2</sup> per side. The operating pressures (feeding, squeezing, blowing and other) were carried out using compressed air regulated by a special pneumatic panel.

The two samples showed good filterability with the filling of the chamber occurring in a short feeding time. The fast cake formation did not cause an optimal compaction of the solids. The residual moisture target of 16 ±0.5% was then reached with cake blowing, using an air flow rate equal to 13,000 NL/h/m<sup>2</sup>, in 3 minutes.

Figure 13-58 shows the pressure filtered cakes of the 100% PFT tailings and the 50/50 PCT/PFT tailings respectively. Both cakes are well formed and friable after squeezing and blowing.



Figure 13-58: Filtered cake of 100% PFT and 50/50 PCT/PFT

It is recommended by AqSepTence that the filter cloth type PP0531-03D of KHOSLA, mono-mono, 300 L/dm<sup>2</sup>/min in PP, be used, which guarantees the automatic operation of the filter press. AqSepTence observed that the filtrate appeared clear after a short initial transient. AqSepTence recommends using a similar cloth with a lower permeability ( $\leq 200$  L/dm<sup>2</sup>/min) should a perfectly clear filtrate be required from the very beginning of the feeding.

## 14. MINERAL RESOURCE ESTIMATES

The mineral resource estimate update presented herein was prepared Carl Pelletier, P.Geo., using all available information.

The main objective was to update the previous NI 43-101 mineral resource estimate for the Horne 5 deposit, which was prepared by InnovExplo and published in a report titled “Technical Report and Mineral Resource Estimate for the Horne No. 5 Deposit”, dated November 7, 2016 (Pelletier et al., 2016) (the “November 2016 MRE”).

The current mineral resource estimate update (the “October 2017 MRE”) is mainly based on changes made to the NSR parameters, supported by new assumptions concerning metal prices and net recoveries. Three additional DDH and 41 updated down hole surveys from the 2015–2016 confirmation drilling program were also used in this October 2017 MRE. No changes to the interpretation were deemed necessary. The resource model for the October 2017 MRE is based largely on the model generated for the November 2016 MRE (Pelletier et al., 2016).

The result of this study is a single mineral resource estimate for six mineralized envelopes: ENV\_A, ENV\_B, ENV\_C, ENV\_D, ENV\_E and ENV\_F. The distribution of metal contents in the main mineralized envelope (ENV\_A) defines 11 high-grade subzones: six for gold (HG\_A to HG\_F), one for copper (Cu\_HG), one for zinc (Zn\_HG) and three for silver (HG\_D, HG\_F and SG\_HD). The resource model is oriented N288, has a strike length of 800 m, a width ranging from 7 m to 120 m, and a vertical depth from 600 m to 2,600 m below surface (see Figure 14-1 below, and Chapter 7 – Geological Setting and Mineralization).

The mineral resources in the October 2017 MRE are not mineral reserves as they do not have demonstrated economic viability. The estimate includes Measured, Indicated and Inferred resources for an underground volume. Resources in the Measured category were reported for the first time on the Horne 5 Project in the November 2016 MRE.

The effective date of the October 2017 MRE is July 25, 2017.

### 14.1 Methodology

The October 2017 MRE detailed in this Report was prepared using GEMS v. 6.8. GEMS was used for modelling purposes, including the construction of 16 mineralized solids, the variography study and the estimation approach, which consisted of 3D block modelling and the inverse distance square (“ID<sup>2</sup>”) interpolation method. Capping and several validations have been realized using Microsoft Access 2013. Basic and spatial statistics were established using a combination of GEMS, Microsoft Excel and Access. Each of the steps described below has been validated once completed:

- Drillhole database compiled and validated in 2013 for additional underground historical drill holes, and in 2015 to 2016 for surface confirmation and proximal exploration drill holes;
- Channel samples database compiled in 2016 for additional underground information;
- Modelling approach based on polymetallic content and lithological information;
- Generation of drill hole intercepts;
- Capping study on raw data;
- Compositing;
- Interpolation strategy using parameters established in the March 2016 MRE, including the variography study, establishment of search ellipsoid parameters and boundaries methodology);
- Block modelling (geometry and structure);
- Resource classification;
- A final MRE statement by category.

Figure 14-1 presents a 3D view looking NE showing the Horne 5 deposit and the bounding box for the block model.

### 14.1.1 Drill Hole Database

The GEMS diamond drill hole database contains 11,040 DDH. The October 2017 MRE uses 5,980 holes in the database (totalling 483,254 m; 220,087 samples), with the remaining holes being too far from the deposit to be of use for the estimation. Of this total, 5,938 are historical underground DDH with accompanying gold, copper and zinc assay results obtained by conventional analytical methods, as well as specific gravity data. The historical underground DDH cover the length of the Project at a fairly regular drill spacing of 15 m in a radiating (fan) pattern from 40 underground working levels and sublevels throughout the deposit (see Figure 14-2).

The database also includes the results of 34 DDH from the 2015–2016 confirmation drilling program that intersect the Horne 5 deposit. Another eight DDH drilled close to the Horne 5 deposit during the 2015–2016 exploration program have also been included.

For silver, the October 2017 MRE used available assays from both underground and surface drilling, and also used the results of an exhaustive multi-element metallurgical testing program comprising 2,112 DDH totalling 75,540 m, grouped into 54 lots assayed for silver (Figure 14-3).

Specific gravity data were compiled in a separate table due to different footages. Specific gravity was calculated for 34,337 samples using their iron contents according to Noranda’s conversion formula as described in Chapter 12 – Data Verification. The specific gravity table also contains 3,897 density measurements from the 2015–2016 confirmation drilling program.



In addition to the basic tables of raw data, the GEMS database contains tables of the calculated drill hole composites required for statistical analysis and resource block modelling.

To integrate historical data into the GEMS project, the original data was converted from the local mine grid (imperial units) to UTM coordinates (metric units) according to the following formula:

**Conversion from Local Mine Grid → UTM**

Easting  $((X*0.302849)+(Y*-0.01028))+642665.12354$

Northing  $((X*0.001673)+(Y*0.304269))+5341760.611935$

**Conversion from UTM → Local Mine Grid**

Easting  $((X*3.301249)+(Y*0.111643))-2717965.988314$

Northing  $((X*-0.018112)+(Y*3.285906))-17540882.914249$

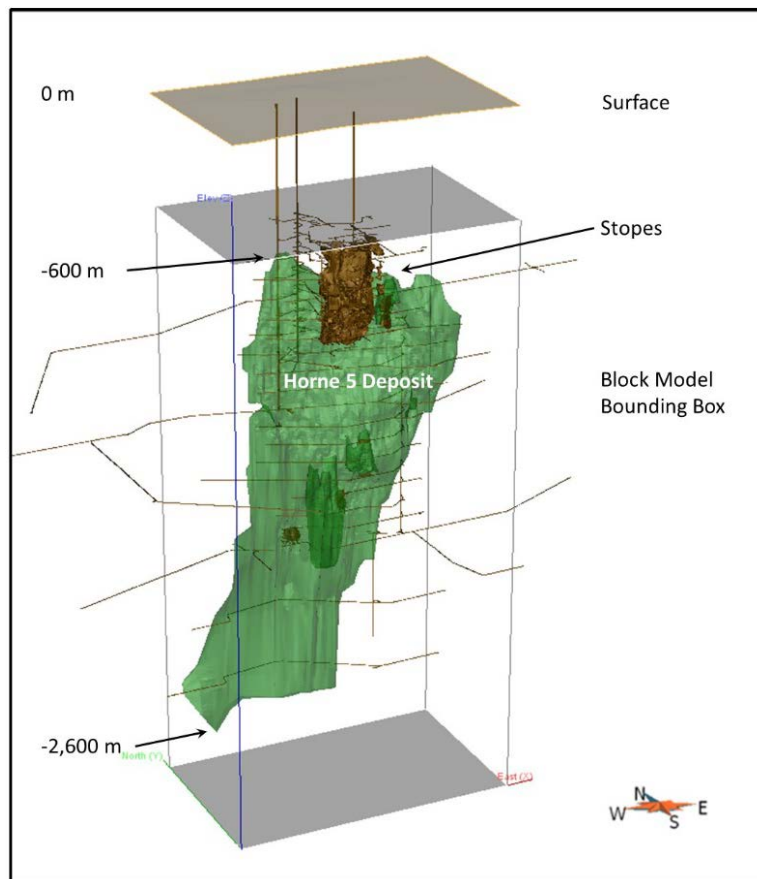

Figure 14-1: 3D view looking NE showing the Horne 5 deposit and the bounding box for the block model



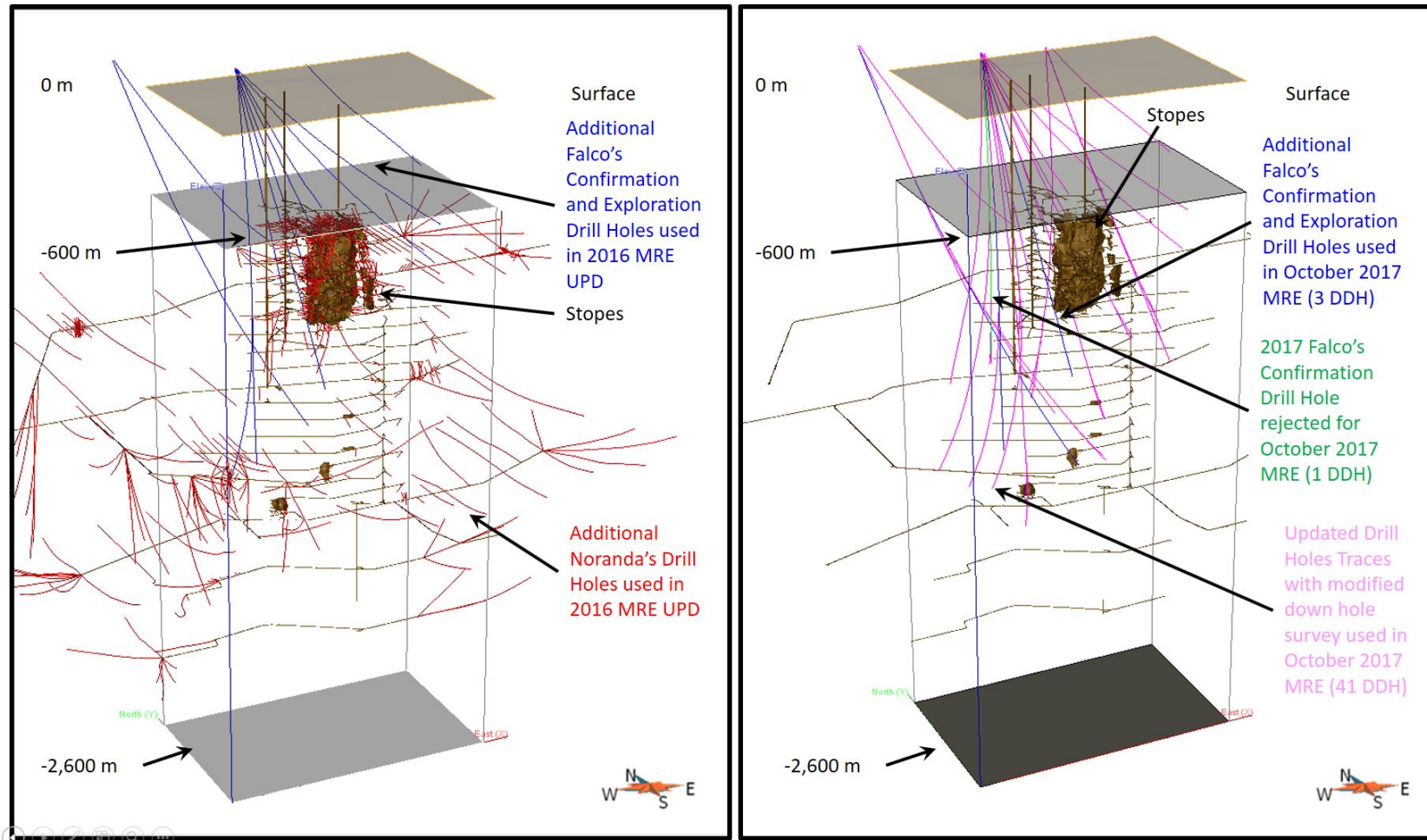

Figure 14-2: 3D view looking NE comparing the DDH used in the November 2016 MRE (left) and the holes added to the October 2017 MRE (right)  
 The additional confirmation and exploration holes are shown in blue.

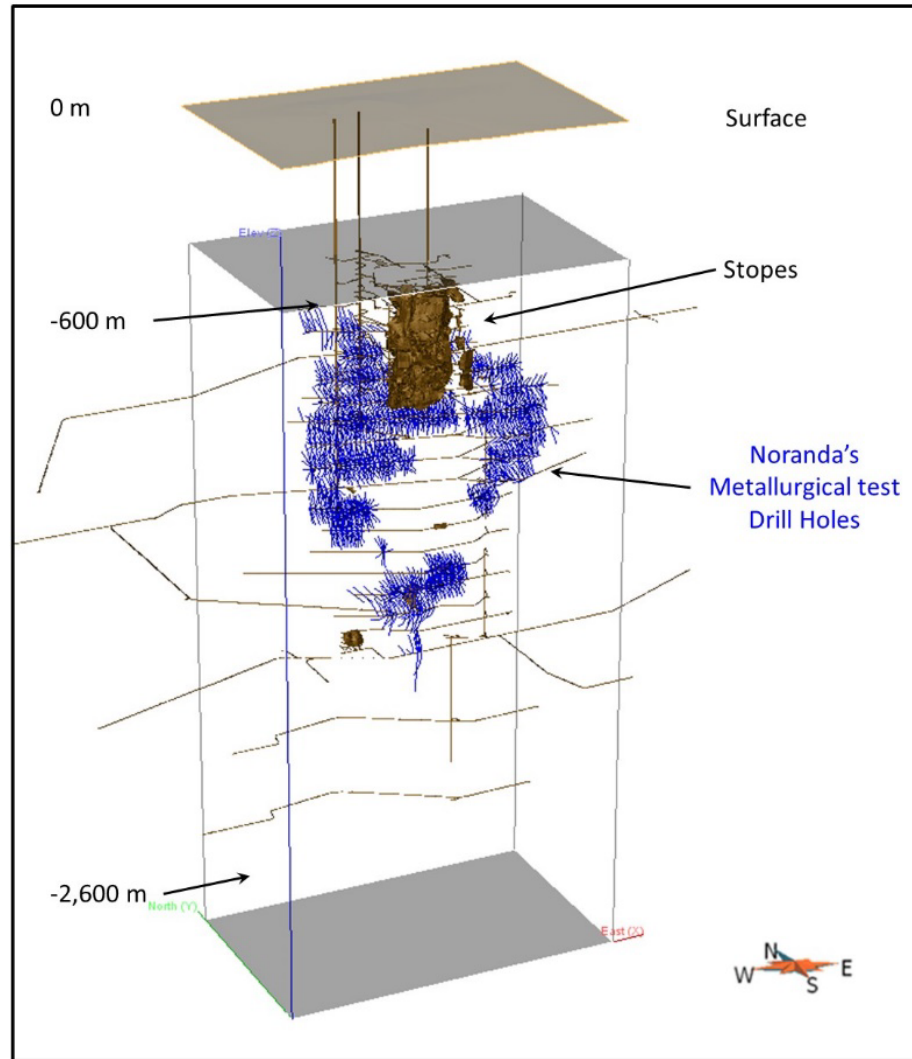

Figure 14-3: 3D view looking NE showing DDH that were used for the historical metallurgical testing program

### 14.1.2 Underground Channel Database

The GEMS underground channel database contains 14,799 samples. Channel samples were compiled and digitized from the available Noranda historical plans in local grid mine (Figure 14-4) and were documented for 23 of the 24 historically developed levels in the Horne 5 deposit (Figure 14-5). The vast majority of the samples were assayed for gold and copper, whereas zinc assays were scarcer and silver was only assayed sparsely at depth between levels 43 and 65. Over the 14,799 compiled and digitized channel samples, 8,915 are associated with mineralized zones.

Where both are available, channel sample grades globally confirm drill holes results for all commodities. Channel samples were also collected continuously along drifts; however, they were not considered for grade interpolation. This decision is supported by the following points:

- Channel sampling does not define the Horne 5 deposit as representatively as drilling information;
- There are several locations where the original plans likely report erroneous grades. For example, some places considered barren based on drilling and geological mapping information show consecutive identical high-grade gold values. These occurrences could not be verified as the original assay certificates could not be found.

In addition to the basic tables of raw data, the GEMS underground channel database contains several tables of the calculated channel composites and wireframe solid intersection composites required for statistical analysis and resource block modelling. The intersections of the interpreted mineralized zones were coded manually to avoid discrepancies during automatic generation due to the distribution of channel samples along drifts.

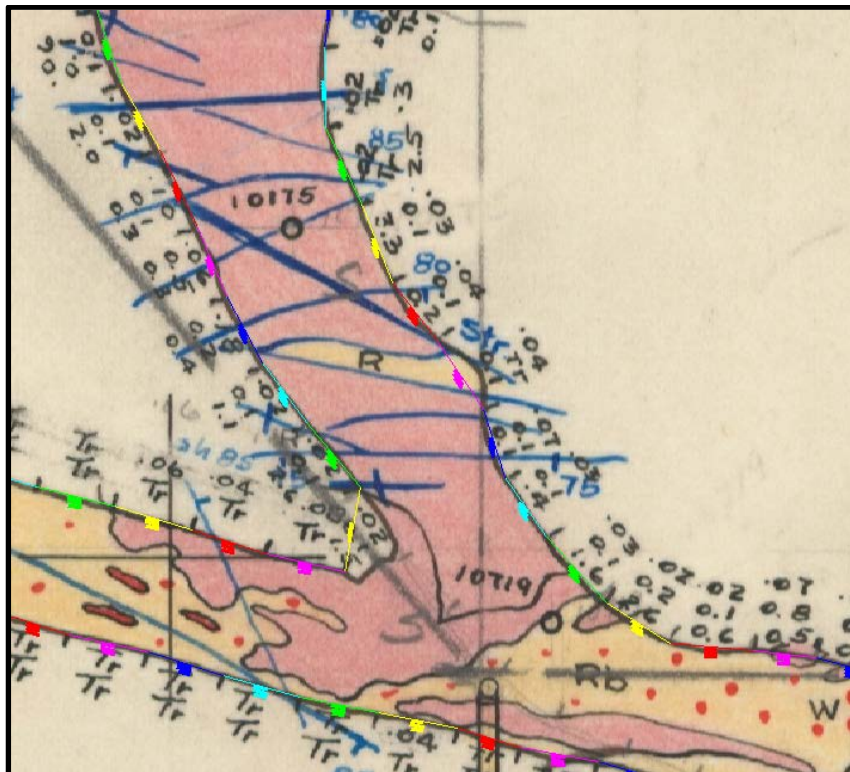

Figure 14-4: Close-up view of one of Noranda's historical plans showing the channel samples and assay results from the historical underground sampling program  
Gold, copper and zinc values for samples are expressed in oz/t, percent and percent, respectively, from top to bottom.

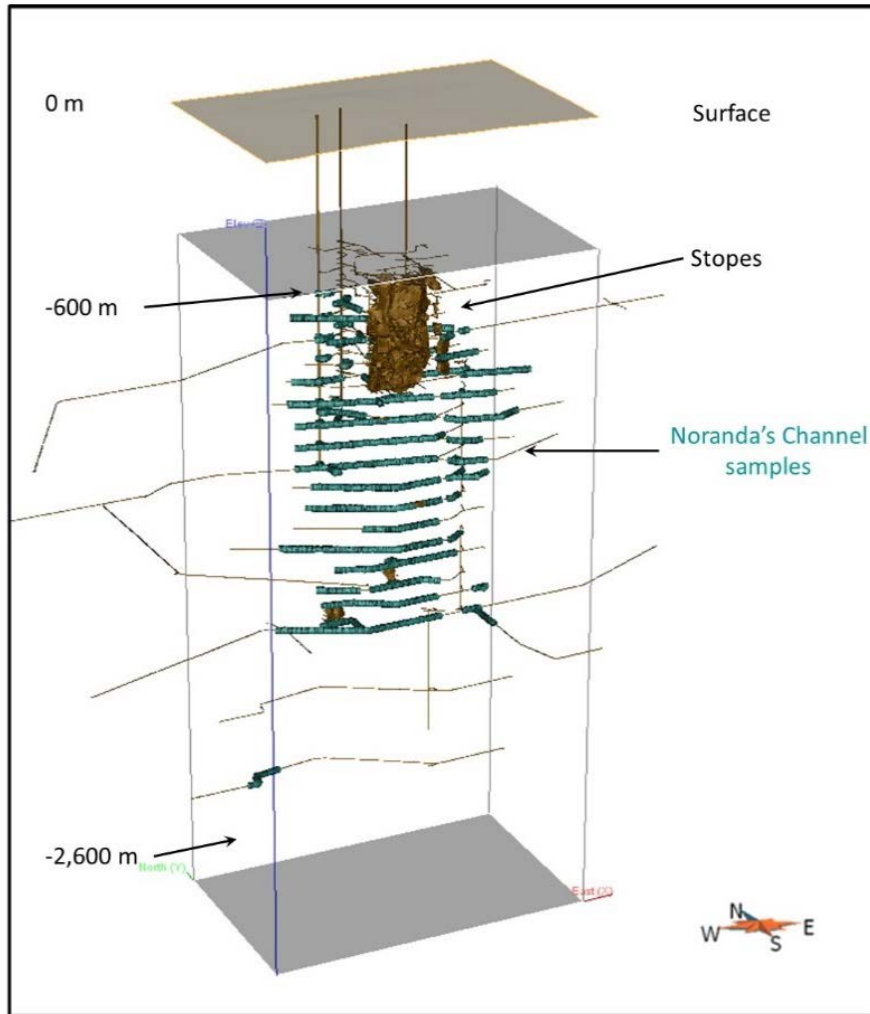

Figure 14-5: 3D view looking NE showing the channel samples with assay results from the historical channel sampling program

### 14.1.3 Developments and Mined-out Voids

The development and mined-out void model used for the October 2017 MRE is based on the one used for the November 2016 MRE, no changes were done to the model since then.

#### 14.1.4 Interpretation of Mineralized Zones

The interpretation used in the October 2017 MRE is based on the previous model generated for the November 2016 MRE (for more information, refer to Chapter 7 – Geological Setting and Mineralization), no changes were done to the model since then.

In order to perform accurate resource modelling of the Horne 5 deposit, InnovExplo constructed a wireframe model that delimits the geologically defined extent of the mineralized zones. The model covers an area with a strike-length of 850 m, a width ranging from 7 m and 120 m, and a vertical depth from 600 m to 2,600 m below surface).

The model outlined zones of continuous gold mineralization using a minimum true thickness of 7 m. The interpretation was not constrained by the presence of historical mine workings (stopes) and barren diabase dikes; these volumes were subtracted later in the mineral estimation process.

The main mineralized envelope (ENV\_A) consists of a disseminated to massive sulphide body hosted by a rhyolite unit. Mineralized envelopes ENV\_B, ENV\_C and ENV\_D are low-grade gold-bearing zones defined using an approximate cut-off grade of 0.5 g/t Au. ENV\_B and ENV\_C are concordant to ENV\_A and located north of it, whereas ENV\_D is deeper and slightly discordant to ENV\_A. The ENV\_A interpretation takes into account assays for gold (approximate cut-off grade of 0.5 g/t Au), copper and zinc, in addition to specific gravity data (which correlates well with sulphide content) and the geological mapping of underground workings (which provides the distribution of disseminated and massive sulphide facies).

ENV\_A is zoned with respect to gold, copper, zinc and sulphides. Six high-grade gold zones (HG\_A to HG\_F) were defined within ENV\_A based on an approximate cut-off of 2.5 g/t Au. The first five high-grade gold zones were slightly modified from the April 2014 mineral resource estimate (April 2014 MRE). HG\_F, defined during the November 2016 MRE study, is located in the deepest portion of ENV\_A. The HG\_E, B, C, D and F zones seem to define an oblique favourable trend, strongly dipping to the west (see Chapter 7 – Geological Setting and Mineralization). High-grade gold zones HG\_A and HG\_B are the two most extensive zones, both about 300 m along strike and about 900 m along dip. The width of the high-grade zones ranges from 10 m to 65 m.

High-grade copper-bearing and zinc-bearing zones were defined within ENV\_A. A preliminary block model based on a 50 m radius search sphere and 5 m composites using unconstrained interpolation led to the definition of isograde shells for copper and zinc. The 0.2% copper and 0.75% zinc shells were used as guides for the interpretation of the more extensive and continuous high-grade copper and zinc zones.



The majority of underground drill holes were not assayed for silver. Only HG\_D, HG\_E and ENV\_D contain DDH that were systematically assayed for silver. ENV\_C does not contain any silver assays. Since silver content correlates well with sulphide content and specific gravity, zones of high specific gravity were defined within ENV\_A at an approximate cut-off of 3.5 t/m<sup>3</sup> and used to interpolate the silver data in ENV\_A.

The wireframe solids of the mineralized-zone model were created by digitizing the interpretation onto sections spaced 15 m apart, then validating with an interpretation digitized onto plan views spaced 30.5 m apart before using tie-lines between sections to complete the wireframes for each solid.

Digitized lines were systematically snapped to historical drill hole information. Digitized lines were also snapped to historical channel sampling information to optimize the shapes of mineralized zones. However, no digitized lines were snapped to Falco's confirmation/exploration drill holes to avoid the influence of imprecise locations for deep holes drilled from surface when compared to short holes drilled from underground.

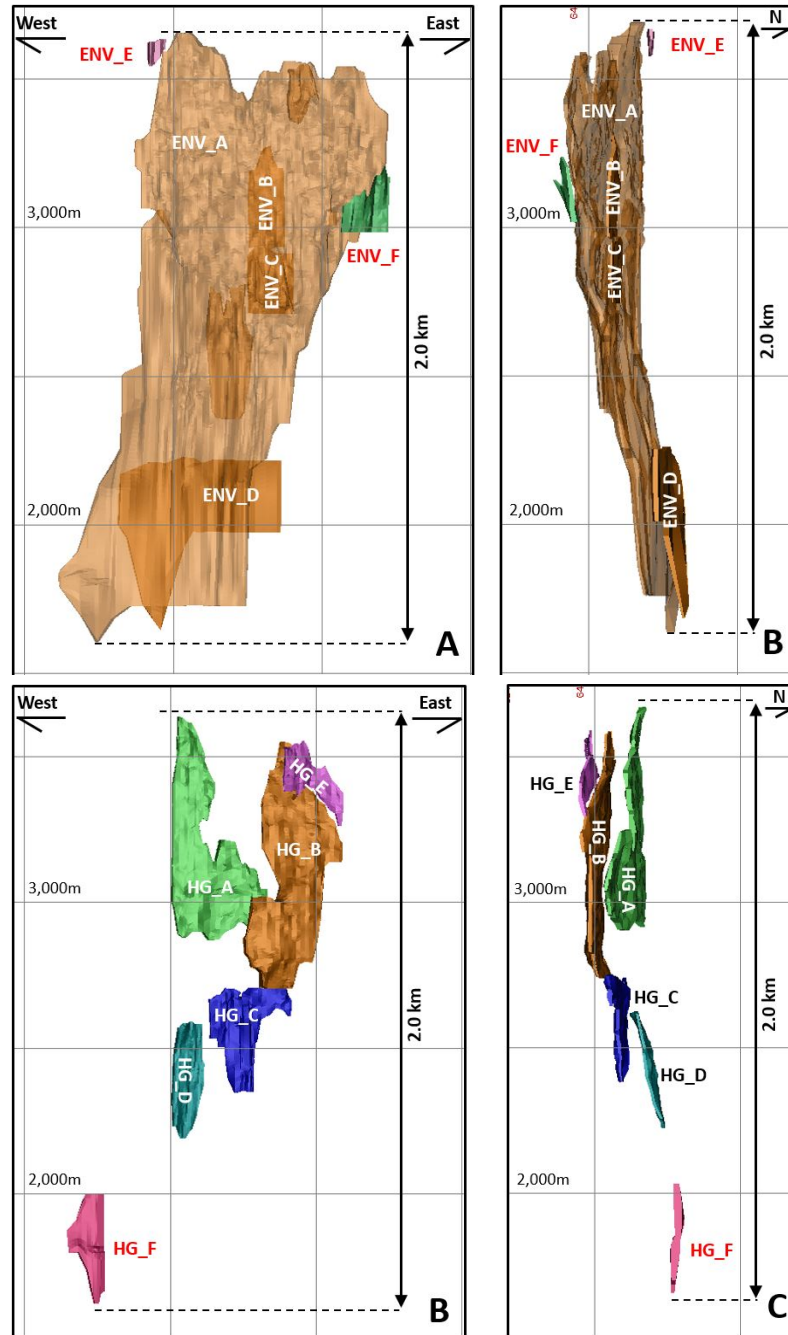

Figure 14-6: Low-grade gold zones (both on top) and high grade gold zones (both at bottom) in the Horne 5 deposit  
 Mineralized zones labelled in red were added in the November 2016 MRE.  
 The side of each square is 500 m.

### 14.1.5 High Grade Capping

For underground drill holes, any assay or specific gravity intervals that intersect the interpreted mineralized zones were automatically coded in the database from 3D solids, and these coded intercepts were used to analyze sample lengths and generate statistics and composites. The silver assays coming from the historical metallurgical testing program were also automatically coded in the database from 3D solids. For the 2015–2016 confirmation and exploration drilling programs, the intersections of the interpreted mineralized zones were coded manually to avoid the influence of imprecise locations for deep holes drilled from surface when compared to short holes drilled from underground.

For underground and surface drilling, basic univariate statistics, probability plots and histograms were generated on raw assay datasets grouped by zones using point area files containing raw assays for each commodity (gold, silver, copper and zinc) and specific gravity data. High grade capping was established on a per zone basis. Within the drill hole database, a total of 96 samples were capped for gold and 33 for silver. Within the silver assay data from the historical metallurgical testing program, 54 assays were capped. No capping was applied to the copper and zinc assays.

Because specific gravity values were calculated from iron assays, InnovExplo applied a capping value of 5.02 g/cm<sup>3</sup> to the specific gravity data, which corresponds to 100% pyrite. A total of 30 samples were capped.

Table 14-1 to Table 14-5 summarizes the statistical analysis for each zone by commodity, and Table 14-6 summarizes the statistical analysis for the specific gravity data.

Table 14-1: Gold – DDH raw assay statistics

Zone	Block code	Number of samples	Max (Ag g/t)	Uncut Mean (Ag g/t)	High Grade Capping (Ag g/t)	Cut Mean (Ag g/t)	Samples cut (#)	Samples capped (%)	Metal factor loss (%)
HG_A	110	9,531	80.91	1.92	35	1.92	14	0.15%	0.80%
HG_B	120	16,058	761.49	2.11	35	1.96	30	0.19%	6.54%
HG_C	130	1,639	117.94	3.32	25	3.06	12	0.73%	7.73%
HG_D	140	1,114	82.97	3.98	35	3.88	8	0.72%	2.82%
HG_E	150	1,361	227.00	3.47	25	3.01	16	1.18%	10.34%
HG_F	160	138	73.37	4.38	35	4.05	2	1.45%	7.54%
ENV_A	210	61,354	171.43	1.06	35	1.05	14	0.02%	0.82%
ENV_B	220	180	22.90	1.54	25	1.54	0	0.00%	0.00%
ENV_C	230	243	15.09	1.49	25	1.49	0	0.00%	0.00%



Zone	Block code	Number of samples	Max (Ag g/t)	Uncut Mean (Ag g/t)	High Grade Capping (Ag g/t)	Cut Mean (Ag g/t)	Samples cut (#)	Samples capped (%)	Metal factor loss (%)
ENV_D	240	279	11.31	1.02	20	1.02	0	0.00%	0.00%
ENV_E	242	51	13.03	1.97	35	1.97	0	0.00%	0.00%
ENV_F	244	350	19.89	1.26	25	1.26	0	0.00%	0.00%
<b>All Zones</b>		<b>92,298</b>	<b>761.49</b>				<b>96</b>		

Table 14-2: Silver – DDH raw assay statistics

Zone	Block code	Number of samples	Max (Ag g/t)	Uncut Mean (Ag g/t)	High Grade Capping (Ag g/t)	Cut Mean (Ag g/t)	# Samples cut	% Samples capped	% loss Metal factor
HG_D	140	710	714.52	35.51	165	32.97	14	1.97%	7.17%
HG_F	160	129	598.29	53.32	165	41.51	7	5.43%	22.15%
SG_HG	250	544	176.00	23.83	100	23.6	3	0.55%	1.06%
ENV_A	255	2,918	714.52	21	110	19.25	48	1.64%	10.57%
ENV_B	220	8	37.30	7.81	100	7.81	0	0.00%	0.00%
ENV_C	230	0	-	-	100	-	-	-	-
ENV_D	240	41	66.51	9.58	100	9.58	0	0.00%	0.00%
ENV_E	242	0	-	-	100	-	-	-	-
ENV_F	244	9	5.60	0.71	100	0.71	0	0.00%	0.00%
<b>All Zones</b>		<b>4,359</b>	<b>714.52</b>				<b>72</b>		

Table 14-3: Silver – Metallurgical test raw assay statistics

Zone	Block code	Number of samples	Max (Ag g/t)	Uncut Mean (Ag g/t)	High Grade Capping (Ag g/t)	Cut Mean (Ag g/t)	# Samples cut	% Samples capped	% loss Metal factor
SG_HG	250	1,056	39.09	19.73	40	19.73	0	0.00%	0.00%
ENV_A	255	2,662	46.29	14.64	40	14.54	54	2.03%	0.55%
<b>All Zones</b>		<b>3,718</b>	<b>46.29</b>				<b>54</b>		

Table 14-4: Copper – DDH raw assay statistics

Zone	Block Code	Number of samples	Max (Cu %)	Uncut Mean (Cu %)
Cu_HG	270	9,426	17.40	0.41
ENV_A	275	76,561	22.20	0.12
ENV_B	220	167	0.50	0.05
ENV_C	230	224	0.92	0.06
ENV_D	240	265	0.55	0.07
ENV_E	242	47	0.67	0.22
ENV_F	244	69	0.98	0.08
<b>All Zones</b>		<b>86,759</b>	<b>22.2</b>	

Table 14-5: Zinc – DDH raw assay statistics

Zone	Block Code	Number of samples	Max (Zn %)	Uncut Mean (Zn %)
Zn_HG	260	21,276	27.10	1.45
ENV_A	265	43,040	23.40	0.41
ENV_B	220	39	0.60	0.08
ENV_C	230	27	4.30	0.28
ENV_D	240	129	7.90	0.40
ENV_E	242	41	3.46	1.10
ENV_F	244	20	0.17	0.04
<b>All Zones</b>		<b>64,572</b>	<b>27.1</b>	

Table 14-6: Specific gravity – DDH values statistics

Zone	Block code	Number of samples	Mean	Median	Min	Max	Capping	# Samples cut	% Samples capped
			SG (g/cm <sup>3</sup> )						
SG_HG	250	8,048	3.68	3.69	2.00	5.34	5.02	9	0.11%
ENV_A	255	21,578	3.24	3.07	1.91	7.14		21	0.10%
ENV_B, ENV_C and ENV_D	220, 230 and 240	28	2.90	2.88	2.81	3.11		0	0.00%
ENV_E	242	37	3.58	3.68	2.71	4.44		0	0.00%
ENV_F	244	15	2.95	2.87	2.74	3.37		0	0.00%
<b>All Zones</b>		<b>29,706</b>						<b>30</b>	

The following criteria were used to decide whether or not capping was warranted, and to determine the threshold when warranted:

- If the quantity of metal contained in the last decile is above 40%, capping is warranted; if below 40%, the uncapped dataset may be used;
- No more than 10% of the overall contained metal must be contained within the first 1% of the highest grade samples;
- The probability plot of grade distribution must not show abnormal breaks or scattered points outside of the main distribution curve;
- The log-normal (“Ln”) distribution of grades must not show any erratic grade bins or distanced values from the main population.

Figure 14-7 and Figure 14-8 provide, as examples, summaries of statistical plots for capping gold assays in the HG\_C high-grade gold zone and the ENV\_A mineralized envelope, respectively.

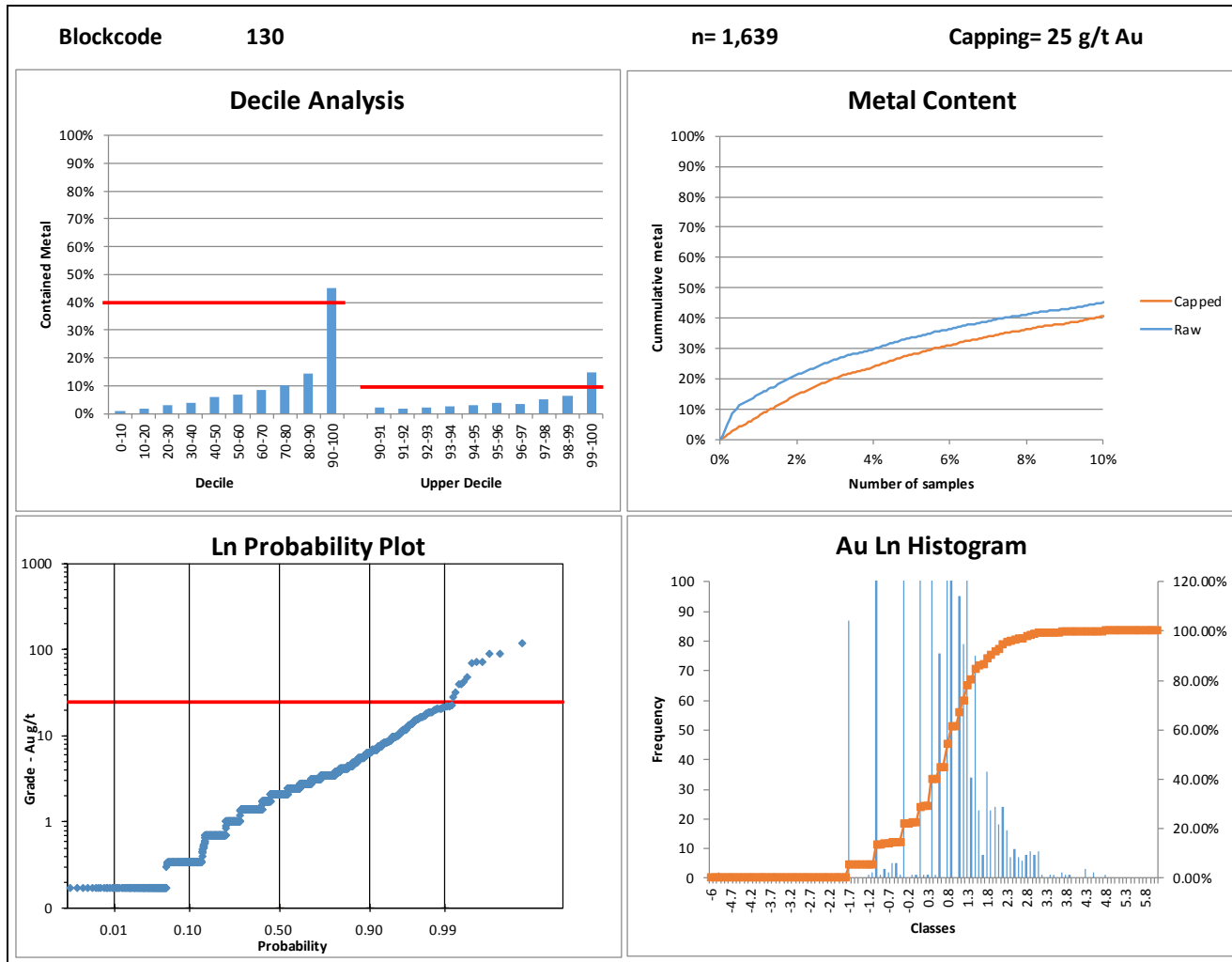

Figure 14-7: Summary statistical plots for gold capping in HG\_C (block code 130)

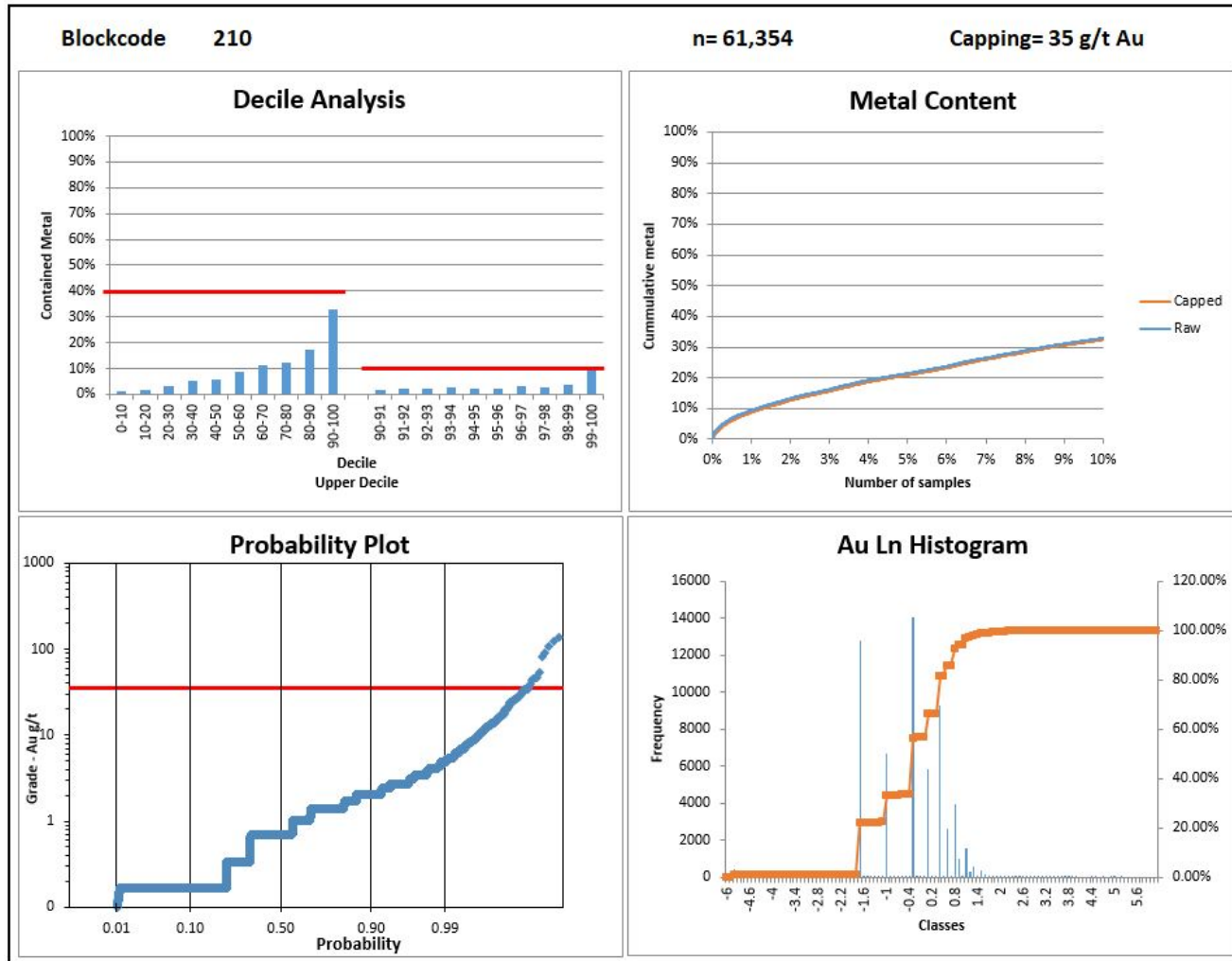

Figure 14-8: Summary statistical plots for capping gold in ENV\_A (block code 210)

### 14.1.6 Compositing

In order to minimize any bias introduced by variable sample lengths, assays of the DDH data were composited to 3-metre equal lengths (3 m composites) within all intervals that define each of the mineralized zones. Composites less than 0.75 m were not created. Three metres was selected because assay lengths of 5 ft (1.52 m) and 10 ft (3.05 m) represent 69% and 27%, respectively, of the assays from underground drilling (Figure 14-9). The silver assays from the historical metallurgical testing program were also composited to 3 m, even though the average length of these samples is approximately 20 m.

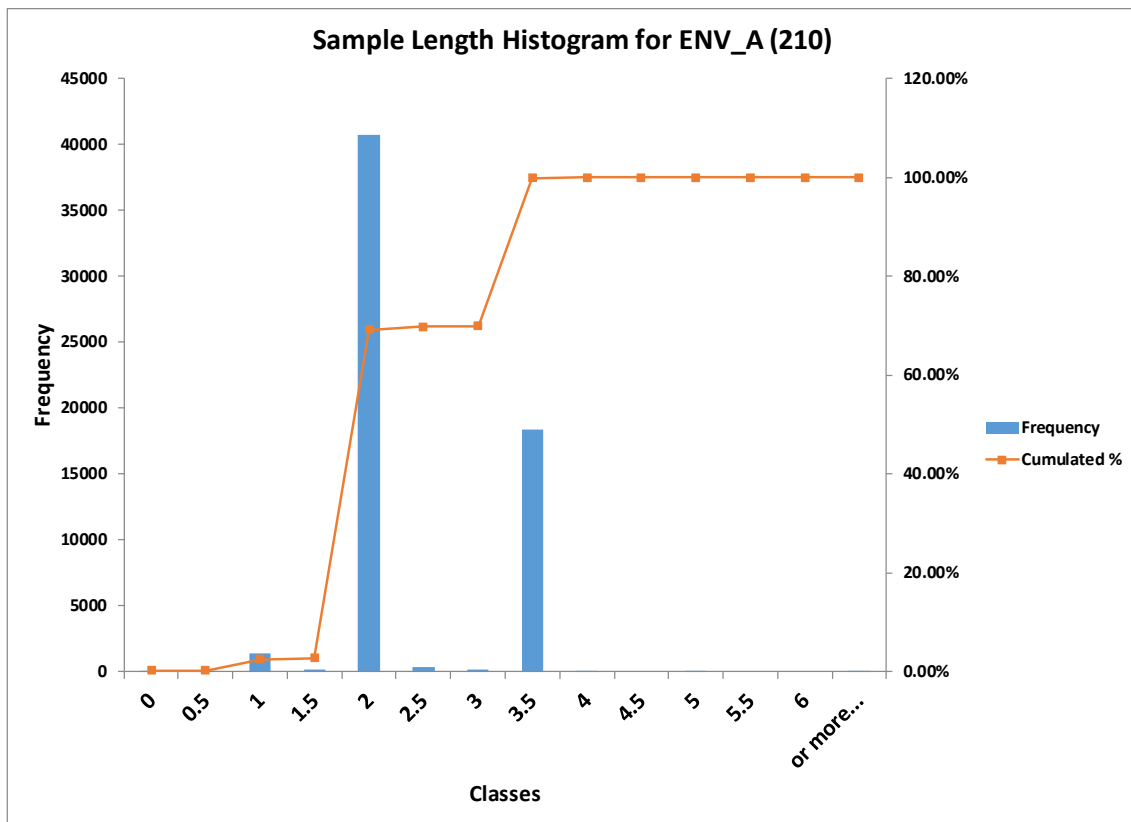

Figure 14-9: Example of histogram illustrating the two main sample length classes identified within ENV\_A (block code 210)

Table 14-7 provides the statistics for the composited capped gold assays in the six high-grade gold zones (HG\_A, HG\_B, HG\_C, HG\_D, HG\_E and HG\_F), the remaining volume of mineralized envelope ENV\_A, and the other five mineralized envelopes (ENV\_B, ENV\_C, ENV\_D, ENV\_E and ENV\_F). A grade of 0.00 was assigned to missing sample intervals.

Table 14-8 provides the statistics for the composited capped silver assays from underground and surface DDH in high-grade gold zones HG\_D and HG\_F, the SG\_HG zone of high specific gravity within ENV\_A, the remaining volume of ENV\_A and mineralized envelope ENV\_D.

Table 14-9 provides the statistics for the composited capped silver assays from the historical metallurgical testing program in the SG\_HG zone of high specific gravity within ENV\_A and the remaining volume of ENV\_A. A grade of 0.00 was assigned to missing sample intervals.

Table 14-10 provides the statistics for a second set of composited capped silver assays where missing sample intervals were ignored. These composites uses only underground DDH from the high-grade gold zone HG\_D, the SG\_HG zone of high specific gravity within ENV\_A, the remaining volume of ENV\_A, and mineralized envelopes ENV\_D and ENV\_F.

Table 14-11 provides the statistics for the composited copper assays in the high-grade copper-bearing zone Cu\_HG, the remaining volume of ENV\_A, and mineralized envelopes ENV\_B, ENV\_C, ENV\_D, ENV\_E and ENV\_F. A grade of 0.00 was assigned to missing sample intervals.

Table 14-12 provides the statistics for the composited zinc assays in high-grade zinc-bearing zone Zn\_HG, the remaining volume of ENV\_A, and mineralized envelopes ENV\_B, ENV\_C, ENV\_D, ENV\_E and ENV\_F. A grade of 0.00 was assigned to missing sample intervals.

Table 14-13 provides the statistics for the composited specific gravity results in the SG\_HG zone of high specific gravity and the remaining volume of ENV\_A. Missing sample intervals were ignored. No composites were calculated within mineralized envelopes ENV\_B, ENV\_C, ENV\_D, ENV\_E and ENV\_F.

**Table 14-7: Gold – 3 m composite statistics**

Zone	Block code	Number of composites	Max (Au g/t)	Mean (Au g/t)	Standard deviation	Coefficient of variation
HG_A	110	5,603	31.62	1.92	2.05	1.07
HG_B	120	9,544	35.00	1.89	2.09	1.10
HG_C	130	1,386	25.00	3.05	3.55	1.16
HG_D	140	920	35.00	3.93	4.50	1.14
HG_E	150	906	25.00	2.77	3.02	1.09
HG_F	160	142	33.63	4.13	4.99	1.21
ENV_A	210	41,096	34.87	1.02	1.09	1.07
ENV_B	220	102	7.91	1.42	1.43	1.00
ENV_C	230	129	13.71	1.48	1.59	1.07
ENV_D	240	212	10.59	1.07	1.16	1.09
ENV_E	242	51	12.74	1.97	2.08	1.05
ENV_F	244	225	10.18	1.14	1.55	1.36
<b>All Zones</b>		<b>60,316</b>				

Table 14-8: Silver – 3 m composite statistics – all DDH

Zone	Block code	Number of composites	Max (Ag g/t)	Mean (Ag g/t)	Standard deviation	Coefficient of variation
HG_D	140	920	110.00	23.60	26.93	1.14
HG_F	160	142	165.00	39.33	37.79	0.96
SG_HG	250	176	70.19	23.48	13.98	0.60
ENV_A	255	481	85.68	12.71	12.74	1.00
ENV_D	240	212	63.52	1.92	6.29	3.28
ENV_F	244	225	1.84	0.01	0.12	13.56
<b>All Zones</b>		<b>2,156</b>				

(Missing samples assigned 0 g/t Ag)

Table 14-9: Silver – 3 m composite statistics – metallurgical tests

Zone	Block Code	Number of composites	Max (Ag g/t)	Mean (Ag g/t)	Standard deviation	Coefficient of variation
SG_HG	250	7,323	40.00	18.70	9.43	0.50
ENV_A	255	18,771	40.00	12.59	8.29	0.66
<b>All Zones</b>		<b>26,094</b>				

Table 14-10: Silver – 3 m composite statistics – underground DDH

Zone	Block Code	Number of composites	Max (Ag g/t)	Mean (Ag g/t)	Standard deviation	Coefficient of variation
HG_D	140	920	110.00	23.60	26.93	1.14
HG_F	160	142	165.00	39.33	37.79	0.96
SG_HG	250	403	70.19	9.42	14.92	1.58
ENV_A	255	2,739	165.00	15.99	22.73	1.42
ENV_F	244	225	1.84	0.01	0.12	13.56
<b>All Zones</b>		<b>4,429</b>				

(Missing samples ignored)



Table 14-11: Copper – 3 m composite statistics

Zone	Block code	Number of composites	Max (Cu Pct)	Mean (Cu Pct)	Standard deviation	Coefficient of variation
Cu_HG	270	6,323	11.63	0.40	0.45	1.12
ENV_A	275	53,375	12.64	0.11	0.17	1.51
ENV_B	220	102	0.47	0.05	0.07	1.57
ENV_C	230	129	0.62	0.05	0.09	1.86
ENV_D	240	212	0.51	0.07	0.08	1.21
ENV_E	242	51	0.66	0.20	0.17	0.82
ENV_F	244	225	0.93	0.02	0.10	4.49
<b>All Zones</b>		<b>60,417</b>				

Table 14-12: Zinc – 3 m composite statistics

Zone	Block code	Number of composites	Max (Zn Pct)	Mean (Zn Pct)	Standard deviation	Coefficient of variation
Zn_HG	260	16,754	21.68	1.29	1.15	0.89
ENV_A	265	42,914	11.90	0.26	0.49	1.89
ENV_B	220	102	0.30	0.02	0.05	3.16
ENV_C	230	129	1.98	0.03	0.21	6.79
ENV_D	240	212	4.68	0.18	0.41	2.30
ENV_E	242	51	3.38	0.89	0.87	0.98
ENV_F	244	225	0.17	0.00	0.02	5.13
<b>All Zones</b>		<b>60,387</b>				

Table 14-13: Specific gravity – 3 m composite statistics

Zone	Block code	Number of composites	Max (S.G. g/cm <sup>3</sup> )	Mean (S.G. g/cm <sup>3</sup> )	Standard deviation	Coefficient of variation
SG_HG	250	16,028	5.02	3.65	0.42	0.12
ENV_A	255	35,267	5.02	3.23	0.39	0.12
<b>All Zones</b>		<b>51,295</b>				

### 14.1.7 Variography and Search Ellipsoids

InnovExplo determined that the added historical underground and confirmation-exploration drilling information does not constitute a material change for variography and search ellipsoid parameters. Parameters used for the October 2017 MRE are the same as those established for the November 2016 MRE for each mineralized domains.

Composites within interpreted high-grade zones and low-grade envelopes were used to generate variography and ultimately determine search ellipsoids.

A 3D directional-specific variographic analysis of the capped 3 m composites was completed for several mineralized zones. Variography analysis was conducted for gold in the five high-grade zones (HG-A to HG-E), in the remaining volume of ENV\_A, and in ENV\_B, ENV\_C and ENV\_D. Variography analysis was conducted for silver using drill hole data in high-grade gold zone HG\_D and in mineralized envelope ENV\_D. In the remaining ENV\_A, variography analysis was conducted for silver using data from the historical metallurgical program according to specific gravity zones. Variography analysis was conducted for copper and zinc in their respective high-grade zones, in the remaining volume of ENV\_A, and in mineralized envelopes ENV\_B, ENV\_C and ENV\_D. Variography analysis was conducted for specific gravity in ENV\_A according to specific gravity zones. Examples of the best-fit major variograms are shown in Figure 14-10.

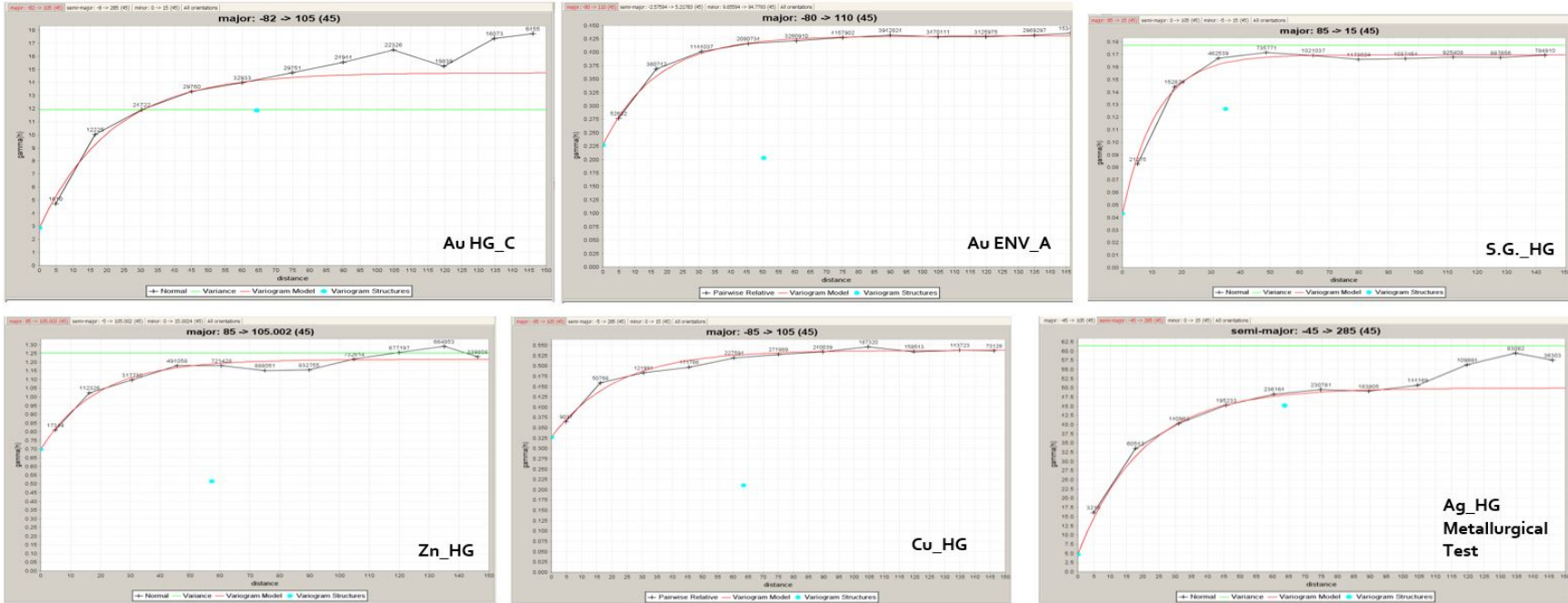

Figure 14-10: Example of 3D variograms along the major axes

The 3D directional-specific investigations yielded the best-fit model along an orientation that roughly corresponds to the strike and dip of the mineralized zones. Some minor changes were introduced to the best-fit models based on the geological model. Most ellipsoid radiuses for the first interpolation pass were established using the ranges determined from the 3D variography combined with drill holes distribution and information from the geological model. For silver, the variography was inconclusive for mineralized envelope ENV\_D, and the gold ellipsoid was used for interpolation. For copper and zinc, variography was inconclusive for mineralized envelopes ENV\_B, ENV\_C and ENV\_D, and the gold ellipsoids were used for interpolation.

For new mineralized domains (ENV\_E, ENV\_F and HG\_F), the authors used arbitrary criteria. ENV\_E uses the same parameters as ENV\_A due to its similar geological and grade characteristics and ENV\_F uses the same parameters as ENV\_B and ENV\_C due to its similar attitude. HG\_F uses the same parameters as HG\_D due to its similar shape and attitude. Furthermore, geological and grade characteristics are also similar for HG\_D and HG\_F; particularly for high-grade silver and gold contents.

Table 14-14 to Table 14-18 summarize the parameters of the final ellipsoids used for interpolation.

**Table 14-14: Gold – final search ellipsoid parameters**

Zone	Block Code	Pass	ORIENTATION			RADIUS			
			P. Az	Dip	I. Az	Ellipsoid	X (m)	Y (m)	Z (m)
HG_A	110	P1	110	-80	290	16AU110	40	20	15
HG_B	120	P1	190	90	97	16AU120	40	35	15
HG_C	130	P1	105	-82	285	16AU130	65	65	15
HG_D	140	P1	296	-79	266	16AU140	55	50	15
HG_E	150	P1	296	-79	266	16AU150	55	50	15
HG_F	160	P1	296	-79	266	16AU160	55	50	15
ENV_A	210	P1	110	-80	5	16AU210	50	35	30
		P2	110	-80	5	16AU210B	100	70	60
ENV_B	220	P1	110	-80	5	16AU220	50	35	30
ENV_C	230	P1	110	-80	5	16AU230	50	35	30
ENV_D	240	P1	266	60	278	16AU240	40	35	15
		P2	266	60	278	16AU240B	80	70	30
ENV_E	242	P1	110	-80	5	16AU242	50	35	30
ENV_F	244	P1	110	-80	5	16AU244	50	35	30

Table 14-15: Silver – final search ellipsoid parameters

Zone	Block Code	Pass	ORIENTATION			RADIUS			
			P. Az	Dip	I. Az	Ellipsoid	X (m)	Y (m)	Z (m)
HG_D	140	P1	341	-74	273	16AG140	50	40	30
HG_F	160	P1	341	-74	273	16AG160	50	40	30
ENV_D	240	P1	266	60	278	16AG240	40	35	15
		P2	266	60	278	16AG240B	80	70	30
SG_HG	250	P1	105	-45	285	16AG250	65	60	30
		P2 / P3	105	-45	285	16AG250B	97.5	90	45
ENV_A	255	P1	105	45	105	16AG255	50	50	25
		P2 / P3	105	45	105	16AG255B	75	75	38

Table 14-16: Copper – final search ellipsoid parameters

Zone	Block Code	Pass	ORIENTATION			RADIUS			
			P. Az	Dip	I. Az	Ellipsoid	X (m)	Y (m)	Z (m)
CU_HG	270	P1	105	-85	285	16CU270	65	55	40
		P2	105	-85	285	16CU270B	130	110	80
ENV_A	275	P1	110	-85	290	16CU275	75	65	45
		P2	110	-85	290	16CU275B	150	130	90
ENV_B	220	P1	110	-80	5	16CU220	50	35	30
ENV_C	230	P1	110	-80	5	16CU230	50	35	30
ENV_D	240	P1	266	60	278	16CU240	40	35	15
		P2	266	60	278	16CU240B	80	70	30
ENV_E	242	P1	110	-80	5	16CU242	50	35	30
ENV_F	244	P1	110	-80	5	16CU244	50	35	30

Table 14-17: Zinc – final search ellipsoid parameters

Zone	Block Code	Pass	ORIENTATION			RADIUS			
			P. Az	Dip	I. Az	Ellipsoid	X (m)	Y (m)	Z (m)
ZN_HG	260	P1	105	85	105	16ZN260	60	60	30
ENV_A	265	P1	105	-85	285	16ZN265	45	35	15
		P2	105	-85	285	16ZN265B	90	70	30
ENV_B	220	P1	110	-80	5	16ZN220	50	35	30
ENV_C	230	P1	110	-80	5	16ZN230	50	35	30
ENV_D	240	P1	266	60	278	16ZN240	40	35	15
		P2	266	60	278	16ZN240B	80	70	30
ENV_E	242	P1	105	-85	285	16ZN242	45	35	15
ENV_F	244	P1	105	-85	285	16ZN244	45	35	15

Table 14-18: Specific gravity – final search ellipsoid parameters

Zone	Block Code	Pass	ORIENTATION			RADIUS			
			P. Az	Dip	I. Az	Ellipsoid	X (m)	Y (m)	Z (m)
SG_HG	250	P1	15	85	105	16SG250	35	35	15
		P2	15	85	105	16SG250B	105	105	45
		P3	15	85	105	16SG250C	500	500	500
ENV_A	255	P1	105	90	105	16SG255	50	40	30
		P2	105	90	105	16SG255B	150	120	90
		P3	105	90	105	16SG255C	500	500	500

### 14.1.8 Block Model Geometry

A block model was established covering the six mineralized envelopes. The model has been pushed down to a depth of approximately 2,880 m below surface and the upper limit was fixed at approximately 435 m below surface. The block dimensions reflect the extent of the mineralized zones. Table 14-19 presents the properties of the Horne 5 deposit block model, and Table 14-20 presents its interpolated zones and their associated folders, as well as details about the naming conventions for the corresponding GEMS solids, rock codes and block codes, and the precedence assigned to each individual solid.

Table 14-19: Horne 5 deposit block model properties

Properties	X (Columns)	Y (Rows)	Z (Levels)
Origin coordinates (UTM Nad83, Zone 17)	647,145	5,345,995	3,850
Origin coordinates - Local Mine Grid (m)	4,651.86	4,227.21	3,810
Number of blocks	238	148	489
Block extent (m)	1,190	740	2,445
Block size	5	5	5
Rotation	Not applied		

#### 14.1.9 Mineralized Zone Block Model

A percent block model was generated using the precedence of solids for the folders *HG\_Zones*, *Envelope* and *Diabase* to reflect the proportion of each solid in each block. All blocks with at least 0.01% of their volume falling within a selected solid were assigned the corresponding block code for that solid (Table 14-20) and its relative proportion (%) in their respective folder.

The multi-folder percent block model thereby generated was used for the interpolation of gold, silver, copper, zinc and specific gravity data. Through different scripts, the grade, percentage, density, metal prices, net recoveries and smelting cost were used to calculate an NSR value for a final combined block model.

Table 14-20: Horne 5 deposit block model and associated solids

Folder	Description	Rock Code	Block Code	GEMS Solid Names			Precedence
				Name 1	Name 2	Name 3	
Standard	<b>WasteBM</b>	WasteBM	500	WasteBM	-	-	500
HG_Zones	<b>High Grade Zones (Gold)</b>	HG_A	110	HG_A	20160906	ClipA	110
		HG_B	120	HG_B	20160418	ClipA	120
		HG_C	130	HG_C	20160420	ClipA	130
		HG_D	140	HG_D	20160524	ClipA	140
		HG_E	150	HG_E	20160419	ClipA	150
		HG_F	160	HG_F	20160519	ClipA	160

Folder	Description	Rock Code	Block Code	GEMS Solid Names			Precedence
				Name 1	Name 2	Name 3	
Envelop	Low Grade Envelopes (Au)	ENV_A	210	ENV_A	20160912	-	210
		ENV_B	220	ENV_B	20160415	-	220
		ENV_C	230	ENV_C	20160415	-	230
		ENV_D	240	ENV_D	20160415	-	240
		ENV_E	242	ENV_E	20160416	-	242
		ENV_F	244	ENV_F	20160415	-	244
Diabase	Diabase N-S Central	D_DIABAS	50	DIABASE	N-S	CENTRAL	50
HG_Cu	All Grade Zones (Cu)	Cu_HG	270	Cu_HG	20160419	ClipA	270
		Cu_HG_D	270	Cu_HG_D	20160419	ClipA	270
		Cu_lowEnv_A	275	Cu_lowEnv_A	20160912		275
HG_Zn	All Grade Zones (Zn)	Zn_HG1	260	Zn_HG1	20160419	ClipA	260
		Zn_HG2	260	Zn_HG2	20160419	ClipA	260
		Zn_HG3	260	Zn_HG3	20160419	ClipA	260
		Zn_HG4	260	Zn_HG4	20160419	ClipA	260
		Zn_HG-D	260	Zn_HG-D	20160419	ClipA	260
		Zn_LowEnv_A	265	Zn_LowEnv_A	20160912		265
HG_SG	All Grade Zones (Density)	SG_HG	250	SG_HG	20151223	ClipA	250
		SG_LowEnv_A	255	SG_LowEnv_A	20160912		255
HG_Ag	All Grade Zones (Ag)	HG_D	140	HG_D	20160524	-	140
		HG_F	160	HG_F	20160519	-	160
		ENV_D	240	ENV_D	20160415	-	240
		SG_HG	250	SG_HG	20151223	ClipA	250
		SG_LowEnv_A	255	SG_LowEnv_A	20160912		255

#### 14.1.10 Grade Interpolation

A grade model was interpolated using the 3 m composites derived from capped (gold and silver) and uncapped (copper and zinc) raw assays in order to produce the best possible grade estimate for the resources in the Horne 5 deposit. The interpolation was done on five point areas: one each for gold, copper and zinc, and two for silver.

A set of three interpolation profiles was established to estimate gold and silver grades, whereas a set of four interpolation profiles was used for copper and zinc grades. The interpolation profiles were customized to estimate grades within each of the high-grade and low-grade folders. The method retained for the final resource estimation was ID<sup>2</sup>.



The composite points were assigned rock codes and block codes corresponding to the mineralized zone in which they occur. The interpolation profiles specify the selected targets and sample rock codes of the mineralized-zone solids, thus establishing hard boundaries between the mineralized zones and preventing block grades from being estimated using sample points with different block codes than the block being estimated. The search/interpolation ellipse orientations and ranges defined for the different interpolation profiles used for grade estimation correspond to those developed in Table 14-14 to Table 14-17 in Section 14.1.7 Variography and search ellipsoids.

For gold, the six high-grade zones in ENV\_A and the mineralized envelopes ENV\_B, ENV\_C, ENV\_E and ENV\_F were interpolated in one pass. The remaining volume of ENV\_A and ENV\_D were interpolated in two passes, with the second pass using an ellipsoid with dimensions two times those of the first pass ellipsoid.

For silver, high-grade gold zones HG\_D and HG\_F were interpolated in one pass. Mineralized envelope ENV\_D was interpolated in two passes with the second pass using an ellipsoid with dimensions two times those of the first pass ellipsoid. Mineralized envelope ENV\_A was interpolated in three passes according to specific gravity zones and source of data. For the first and second passes, the interpolation used composites from the historical metallurgical testing program and the 2015 confirmation drilling program, for which a value of 0 g/t Ag was assigned to missing sample intervals. For the third pass, the interpolation used the same composites supplemented by the composites from underground drilling, for which missing sample intervals were ignored. The second and third passes used an ellipsoid with dimensions corresponding to one and a half times the dimensions of the first pass ellipsoid.

For copper, mineralized envelopes ENV\_B, ENV\_C, ENV\_E and ENV\_F were interpolated in one pass. The high-grade copper-bearing zone (Cu\_HG), the remaining volume of ENV\_A and mineralized envelope ENV\_D were interpolated in two passes with the second pass using an ellipsoid with dimensions two times those of the first pass ellipsoid.

For zinc, the high-grade zinc-bearing zone (Zn\_HG) and mineralized envelopes ENV\_B, ENV\_C, ENV\_E and ENV\_F were interpolated in one pass. The remaining volume of ENV\_A and mineralized envelope ENV\_D were interpolated in two passes with the second pass using an ellipsoid with dimensions two times those of the first pass ellipsoid. Only one pass for high-grade zinc-bearing zone (Zn\_HG) was used for interpolation due to the density of available data.

The specifications to control the grade estimation are as follows:

- ID<sup>2</sup> interpolation method;
- Minimum of two and maximum of 12 sample points in the search ellipse for interpolation;
- No maximum number of sample points per DDH;
- High-grade values capped for gold and silver;
- Uncapped values for copper and zinc.

#### 14.1.11 Specific Gravity

A specific gravity model was interpolated using the 3 m composites derived from capped specific gravity data in order to produce the best possible density estimate for mineralized envelope ENV\_A. The interpolation was done on a point area combining all DDH datasets.

A set of three interpolation profiles was established to estimate the specific gravity for mineralized envelope ENV\_A. The interpolation profiles were customized to estimate the specific gravity within the high-grade and low-grade folders. The method retained for the final specific gravity estimation was ID<sup>2</sup>.

The composite points were assigned rock codes and block codes corresponding to the mineralized zone in which they occur. The interpolation profiles specify the selected targets and sample rock codes of the mineralized-zone solids, thus establishing hard boundaries between the mineralized zones and preventing block grades from being estimated using sample points with different block codes than the block being estimated. The search/interpolation ellipse orientations and ranges defined for the different interpolation profiles used for grade estimation correspond to those developed in Table 14-18 of Section 14.1.7 Variography and search ellipsoids.

Specific gravity was interpolated in three passes. The ellipsoid radiuses from Pass 1 correspond to the ranges determined from the geostatistical analysis. Pass 2 used an ellipsoid with dimensions corresponding to three times the dimensions of the first pass. Pass 3 used a sphere with a radius set at 500 m to interpolate blocks that were not interpolated in the previous pass.

A fixed value of 2.88 g/cm<sup>3</sup> was assigned to the low-grade envelopes ENV\_B, ENV\_C and ENV\_D, representing the median of the available data. This was necessary due to the scarcity of the data.

A fixed value of 2.88 g/cm<sup>3</sup> was arbitrarily assigned to the low-grade envelope ENV\_E. The average of raw data returned 3.58 g/cm<sup>3</sup> but this value was not retained. A fixed value of 2.67 g/cm<sup>3</sup> was assigned to the low-grade envelope ENV\_F, which was considered more appropriate given its quartz vein mineralization style. The average of raw data returned 2.95 g/cm<sup>3</sup> but this value was not retained. This conservative approach was employed by the authors to avoid tonnage overestimations.

The specifications to control the grade estimation are as follows for the three sets of interpolation profiles:

- ID<sup>2</sup> interpolation method;
- Minimum of two and maximum of 12 sample points in the search ellipse for interpolation;
- No maximum number of sample points per DDH;
- High values capped to 5.02.

## 14.1.12 Block Model Validation

### Visual Comparison

A visual comparison between the block model grades and the composite grades was conducted on sections, plans and in 3D. No significant differences were observed during the comparison.

### Global Statistical Comparison

A summary of statistics per zone on cut assays, composites and blocks at a cut-off grade of 0 is presented in Table 14-21 to Table 14-24 for gold, silver, copper and zinc, respectively. It shows that raw assays and composite average grades are generally similar. It also shows that for gold and silver, the mean block grades are generally lower than the mean composite grades, while for copper and zinc, the mean block grades are generally similar or slightly higher than the mean composite grades.

Table 14-21: Statistics for gold by zone – cut assays, composites and block grades (0 g/t cut-off)

Zone	Block Code	Raw Assays (cut)		Composites		Block Model (>50% In zone)	
		Number	Mean (Au g/t)	Number	Mean (Au g/t)	Number	Mean (Au g/t)
HG_A	110	9531	1.92	5603	1.920657148	22538	1.857
HG_B	120	16058	1.96	9544	1.890821563	36914	1.66
HG_C	130	1639	3.06	1386	3.052613997	6258	2.888
HG_D	140	1114	3.88	920	3.931472826	5138	3.3734
HG_E	150	1361	3.01	906	2.769433775	2527	2.511
HG_F	160	138	4.05	142	4.128739437	4505	3.644
ENV_A	210	61354	1.05	41096	1.023561874	322655	0.957
ENV_B	220	180	1.54	102	1.421941176	2576	1.29
ENV_C	230	243	1.49	129	1.481186047	2278	1.256
ENV_D	240	279	1.02	212	1.065084906	26167	0.688
ENV_E	242	51	1.97	51	1.971647059	387	1.863
ENV_F	244	350	1.26	225	1.136657778	2226	0.86

Table 14-22: Statistics for silver by zone – cut assays, composites and block grades (0 g/t cut-off)

Zone	Block Code	Raw Assays (cut)		Composites (cut)		Block Model (>50% In zone)	
		Number	Mean (Ag g/t)	Number	Mean (Ag g/t)	Number	Mean (Ag g/t)
HG_SG	250	1600	21.04	6949	20.30	85393	15.78
ENV_A	255	5580	17.00	18558	15.11	322655	12.50
HG_D	140	710	32.97	920	23.60	5138	18.06
ENV_D	240	41	9.58	212	1.92	26167	0.87

Table 14-23: Statistics for copper by zone – cut assays, composites and block grades (0 g/t cut-off)

Zone	Block Code	Raw Assays		Composites		Block Model (>50% In zone)	
		Number	Mean (Cu %)	Number	Mean (Cu %)	Number	Mean (Cu %)
CU_HG	270	9426	0.41	6323	0.40	23144	0.43
ENV_A	275	76561	0.12	53375	0.11	322655	0.13
ENV_B	220	167	0.05	102	0.47	2576	0.05
ENV_C	230	224	0.06	129	0.05	2278	0.05
ENV_D	240	265	0.07	212	0.07	26167	0.05
ENV_E	242	47	0.22	51	0.2	387	0.22
ENV_F	244	69	0.08	225	0.02	2226	0.02

Table 14-24: Statistics for zinc by zone – cut assays, composites and block grades (0 g/t cut-off)

Zone	Block Code	Raw Assays		Composites		Block Model (>50% In zone)	
		Number	Mean (Zn %)	Number	Mean (Zn %)	Number	Mean (Zn %)
ZN_HG	260	21276	1.45	16754	1.29	75416	1.33
ENV_A	265	43040	0.41	42914	0.26	322655	0.59
ENV_B	220	39	0.08	102	0.02	2576	0.02
ENV_C	230	27	0.28	129	0.03	2278	0.03
ENV_D	240	129	0.40	212	0.18	26167	0.11
ENV_E	242	41	1.10	51	0.89	387	1.01
ENV_F	244	20	0.04	225	0.00	2226	0.00

## Probability Plots

Probability plots for gold, silver, copper and zinc were constructed for each zone to compare the grade populations of capped raw assays, composites and blocks (at a cut-off grade of 0). It generally shows that the three populations have similar distributions, flattening from capped raw assays to composites to blocks, reflecting the smoothing of the data at each step of the process. Figure 14-11 and Figure 14-12 provide examples of probability plots for the high-grade HG\_C gold zone and the ENV\_A mineralized envelope.

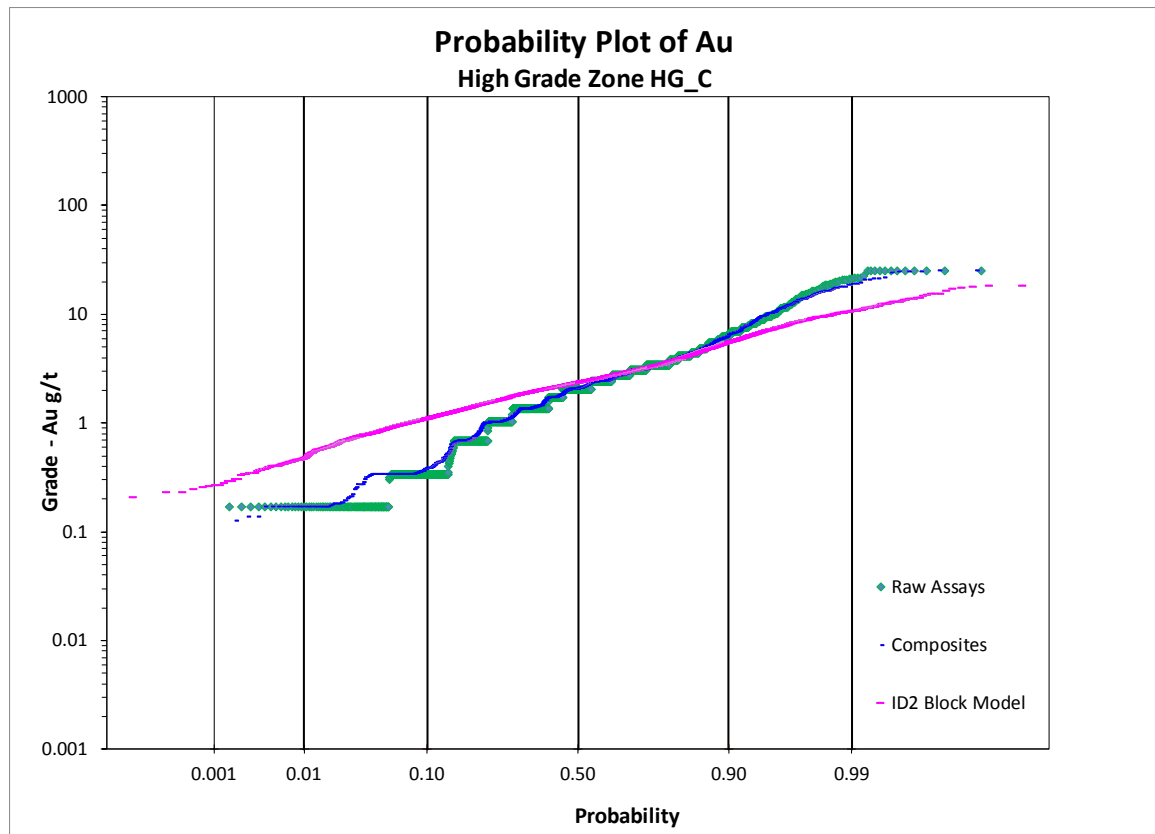

Figure 14-11: Probability plot of gold for high-grade zone HG\_C

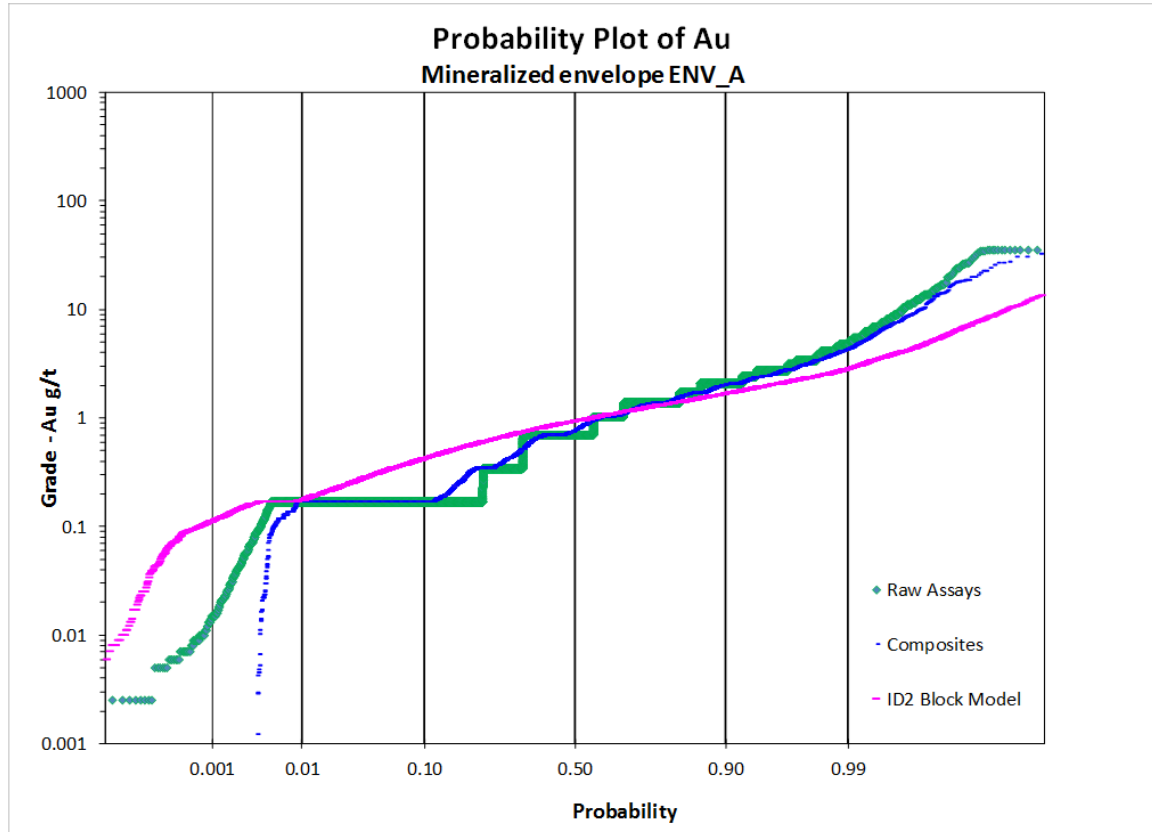

Figure 14-12: Probability plot of gold for mineralized envelope ENV\_A

### Swath Plots

Swath plots for gold, silver, copper and zinc were constructed at vertical intervals of 100 m for the principal mineralized envelope ENV\_A (Figure 14-13 to Figure 14-16). The plots for gold, copper and zinc include all the data within the high-grade zones (HG-A to HG-E) and the remaining volume of envelope ENV\_A. For silver, only data from the high-grade zone HG\_SG was plotted due to the scarcity and mixed sources of the data in the remaining volume of ENV\_A. The plots demonstrate that variability is generally greater at depth where there are fewer composites.

For elevations above 2,600 m, the following information can be drawn from the plots: 1) for gold, the interpolated grade is lower than the raw assay and composite grades; 2) for silver, the interpolated grade is higher than the raw assay and composite grades, but only at the extremities of the zone where data are scarce; 3) for copper, the interpolated grade is lower or very slightly higher than the raw assay and composite grades; and 4) for zinc, the interpolated grade is generally lower than the raw assay grades but higher than the composites grades.

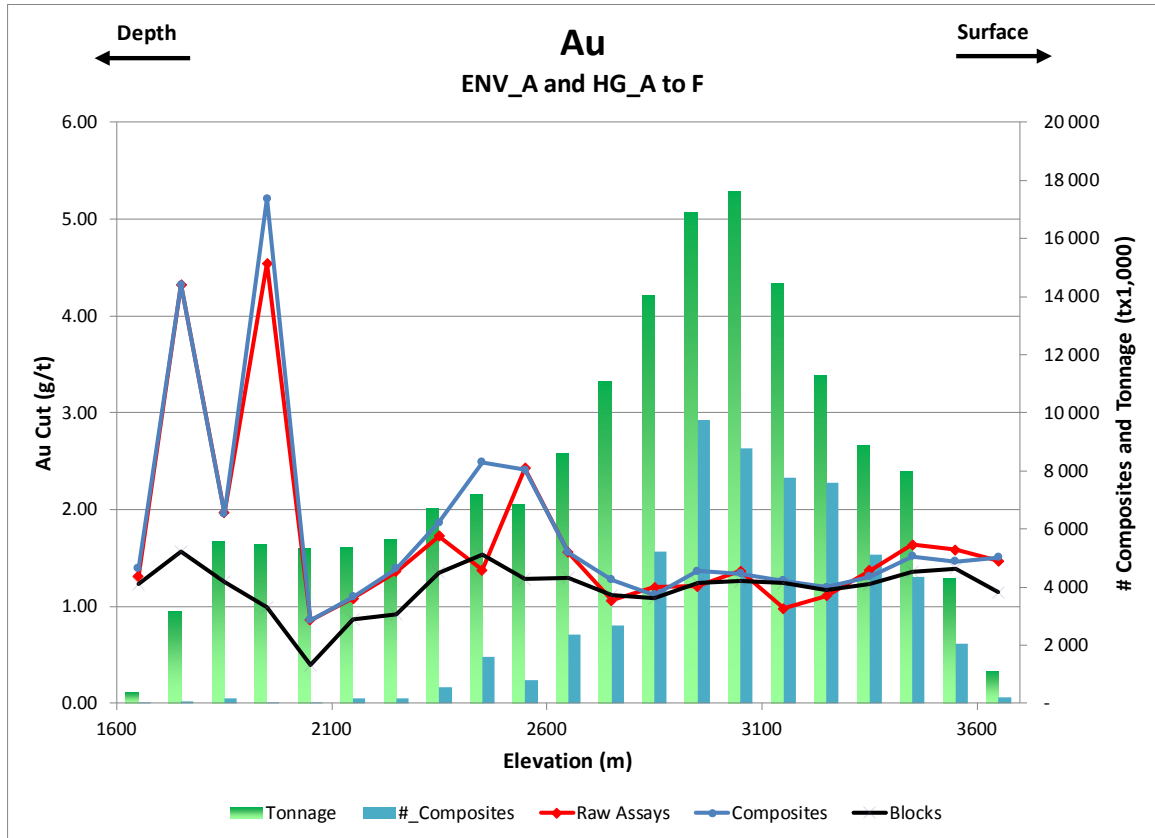

Figure 14-13: Gold swath plot (100 m vertical) of ENV\_A and HG\_A to HG\_E

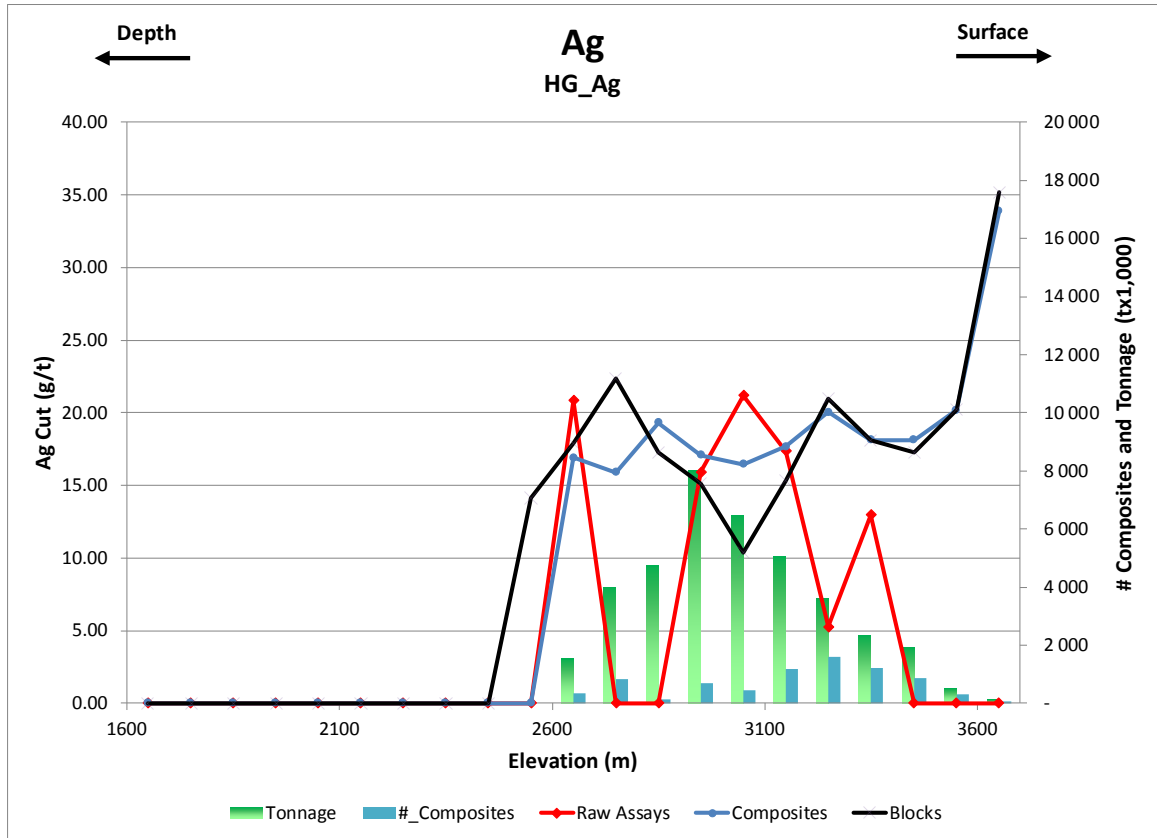

Figure 14-14: Silver swath plot (100 m vertical) of HG\_Ag (block code 250)



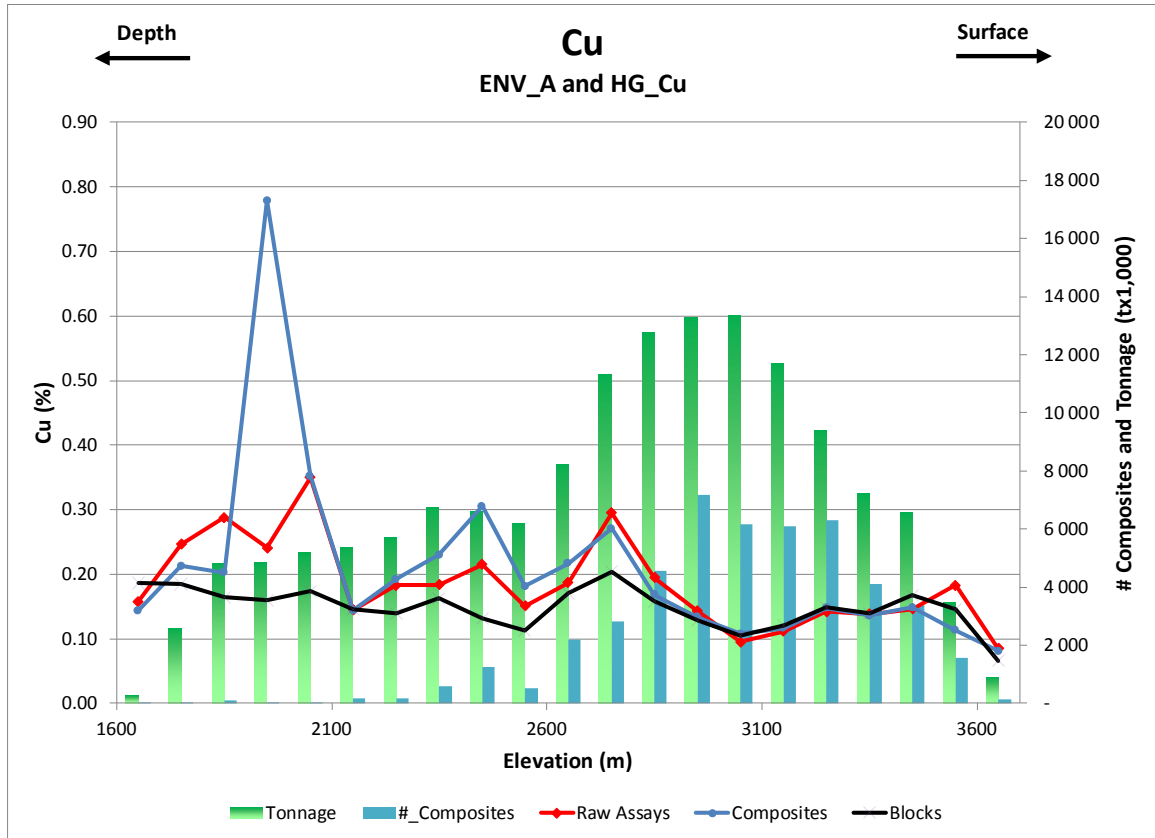

Figure 14-15: Copper swath plot (100 m vertical) of HG\_Cu and ENV\_A

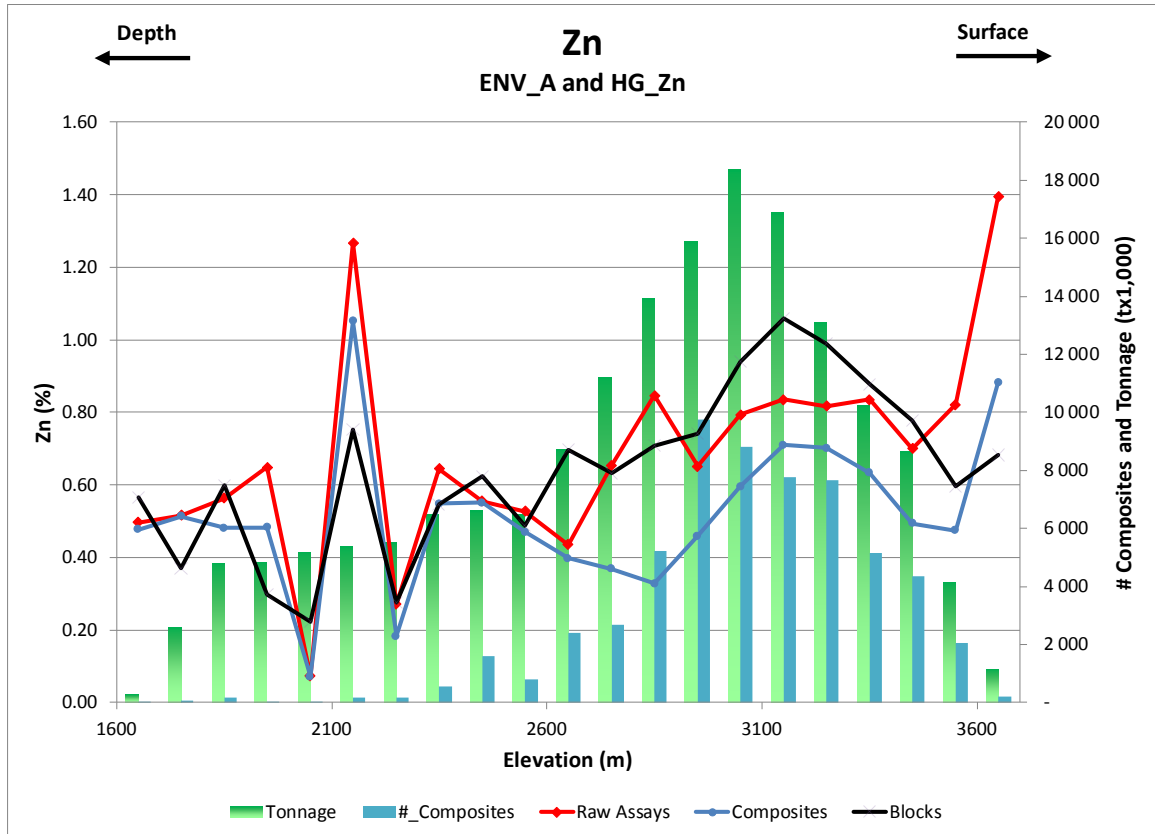

Figure 14-16: Zinc swath plot (100 m vertical) of HG\_Zn and ENV\_A

### 14.1.13 NSR and Cut-off

Given the polymetallic (gold, silver, copper and zinc) nature of the sulphide mineralization comprising the Horne 5 deposit, InnovExplo created an NSR block model by calculating the NSR value of each mineralized block.

For the purpose of the November 2016 MRE, the value of one tonne of mineralized material is given by the following formula:

$$\begin{aligned}
 \text{NSR Value (CAD/t)} = & (\text{Au (g/t)} \times 0.03215 \times \text{Au net recovery} \times \text{Au USD price} \times \text{Exchange rate} \\
 & + \text{Ag (g/t)} \times 0.03215 \times \text{Ag net recovery} \times \text{Ag USD price} \times \text{Exchange rate} \\
 & + \text{Cu (\%)} \times 22.05 \times \text{Cu net recovery} \times \text{Cu USD price} \times \text{Exchange rate} \\
 & + \text{Zn (\%)} \times 22.05 \times \text{Zn net recovery} \times \text{Zn USD price} \times \text{Exchange rate}) \\
 & - \text{Smelting cost CAD/t}
 \end{aligned}$$

One of the major changes in the October 2017 MRE is the use of variable recovery factors for each commodity. The equations to establish the net recovery are presented in Chapter 13. Metal prices and the exchange rate inspired from a long term analyst consensus price forecast study established in July 2017 are as follows: gold 1,300 USD/oz; silver 19.50 USD/oz; copper 2.90 USD/lb; zinc 1.10 USD/lb; exchange rate 1.28 CAD/1.00 USD.

Smelting cost, including transportation, is based on the Mining Cost Service (<http://costs.infomine.com/>) as well as on non-public smelter contract obtained from one of the proposed destinations and on talks with transport providers. Smelting cost value used for the NSR calculation is 6.52 \$/t.

A NSR cut-off was therefore used in the resource estimation to take into account all commodities. The October 2017 MRE was compiled at variable NSR cut-off values. The official resource is reported at a NSR cut-off of 55 \$/t. The underground NSR cut-off is based on conclusions from the PEA. The estimate is based on the costs per tonne presented in Table 14-25.

A NSR cut-off was therefore used in the resource estimation to take into account all commodities. The October 2017 MRE is compiled at variable NSR cut-off values. The official resource is reported at a NSR cut-off of 55 \$/t. The underground NSR cut-off is based on conclusions from the PEA. The estimate is based on the costs per tonne presented in Table 14-25.

**Table 14-25: Breakdown of the underground NSR cut-off estimation for the Horne 5 deposit mineral resource estimate**

Input parameter	Value (\$/t)
Mining costs	12.39
Milling costs	20.63
G&A	21.98
<b>Total cost</b>	<b>\$55.00</b>

## 14.2 Mineral Resource Classification

The resource classification definitions used for this Report are those published by the Canadian Institute of Mining, Metallurgy and Petroleum in their document “CIM Definition Standards for Mineral Resources and Reserves”.

**Measured Mineral Resource:** that part of a mineral resource for which quantity, grade or quality, densities, shape and physical characteristics are estimated with confidence sufficient to allow the application of Modifying Factors to support detailed mine planning and final evaluation of the economic viability of the deposit.

Geological evidence is derived from detailed and reliable exploration, sampling and testing and is sufficient to confirm geological and grade or quality continuity between points of observation.

**Indicated Mineral Resource:** that part of a mineral resource for which quantity, grade or quality, densities, shape and physical characteristics are estimated with sufficient confidence to allow the application of Modifying Factors in sufficient detail to support mine planning and evaluation of the economic viability of the deposit.

Geological evidence is derived from adequately detailed and reliable exploration, sampling and testing and is sufficient to assume geological and grade or quality continuity between points of observation.

An Indicated mineral resource has a lower level of confidence than that applying to a Measured mineral resource and may only be converted to a Probable mineral reserve.

**Inferred Mineral Resource:** that part of a mineral resource for which quantity and grade or quality are estimated on the basis of limited geological evidence and sampling. Geological evidence is sufficient to imply but not verify geological and grade or quality continuity.

An Inferred mineral resource has a lower level of confidence than that applying to an Indicated mineral resource and must not be converted to a mineral reserve. It is reasonably expected that the majority of Inferred mineral resources could be upgraded to Indicated mineral resources with continued exploration.

#### 14.2.1 Horne 5 Deposit Classification

By default, interpolated blocks were assigned to the Inferred category during the creation of the grade block model.

The reclassification to the Indicated category was established for blocks meeting all the following condition:

- Blocks showing geological and grade continuity;
- Blocks for which the distance to the closest composite is less than 25 m.

An interpretation on longitudinal view was generated using the criteria described above, and the blocks were recoded accordingly. Within this clipping boundary, some Inferred blocks have been upgraded to the Indicated category, whereas outside the boundary, some Indicated blocks have been downgraded to the Inferred category. InnovExplo is of the opinion that this was a necessary step to homogenize (smooth out) the resource volumes in each category.

For blocks of the Indicated category, where the silver grade was estimated by the third interpolation pass, the silver grade was downgraded to 0 g/t. This last operation ensures that the grades of every metal within the Indicated category are based on composites where a grade of 0 g/t was assigned to missing sample intervals.

The reclassification to the Measured category was established for blocks meeting all the following condition:

- Blocks showing geological and grade continuity;
- Blocks meeting the Indicated classification;
- Blocks for which the distance to the closest sampled drift is less than 15 m. For this purpose, a composite data set from underground historical channel samples was used. Moreover, to prevent blocks from being classified into the Measured category in mineralized zones that are not intersected by sampled drifts, a hard-boundary constraint was applied (Figure 14-17).

The average distance to the nearest composite is 6.97 m for Measured mineral resources, 10.01 m for Indicated resources and 40.10 m for Inferred mineral resources.

Figure 14-18 displays the distribution of Inferred, Indicated and Measured categories in the Horne 5 deposit.

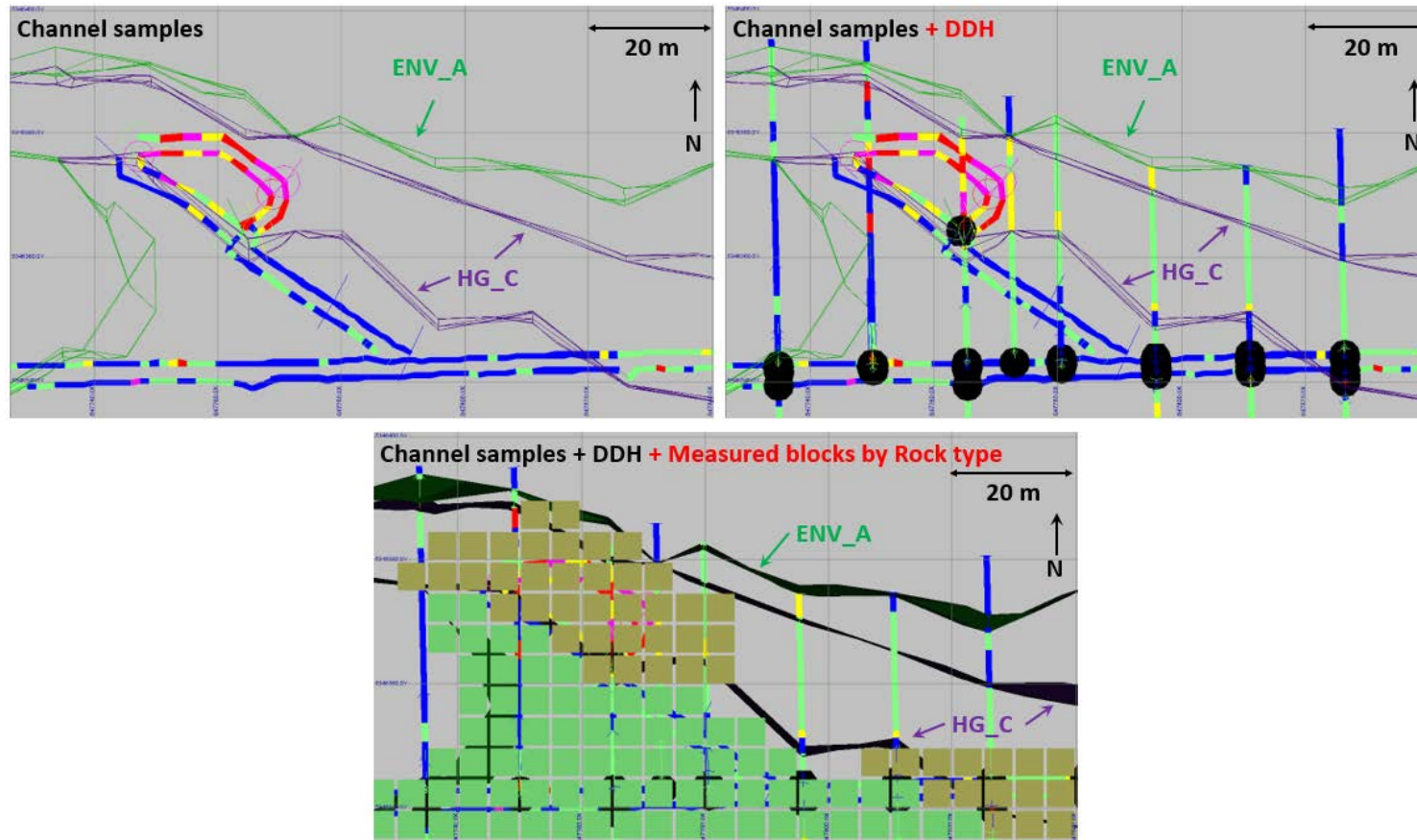

Figure 14-17: 3D plan view looking down on level 43 illustrating how mineralized zones are supported by channel samples (top left) and DDH information (top right) with gold assays  
The hard-boundary constraint is used to prevent smearing of Measured blocks into mineralized zones that are not intersected by sampled drifts (bottom).

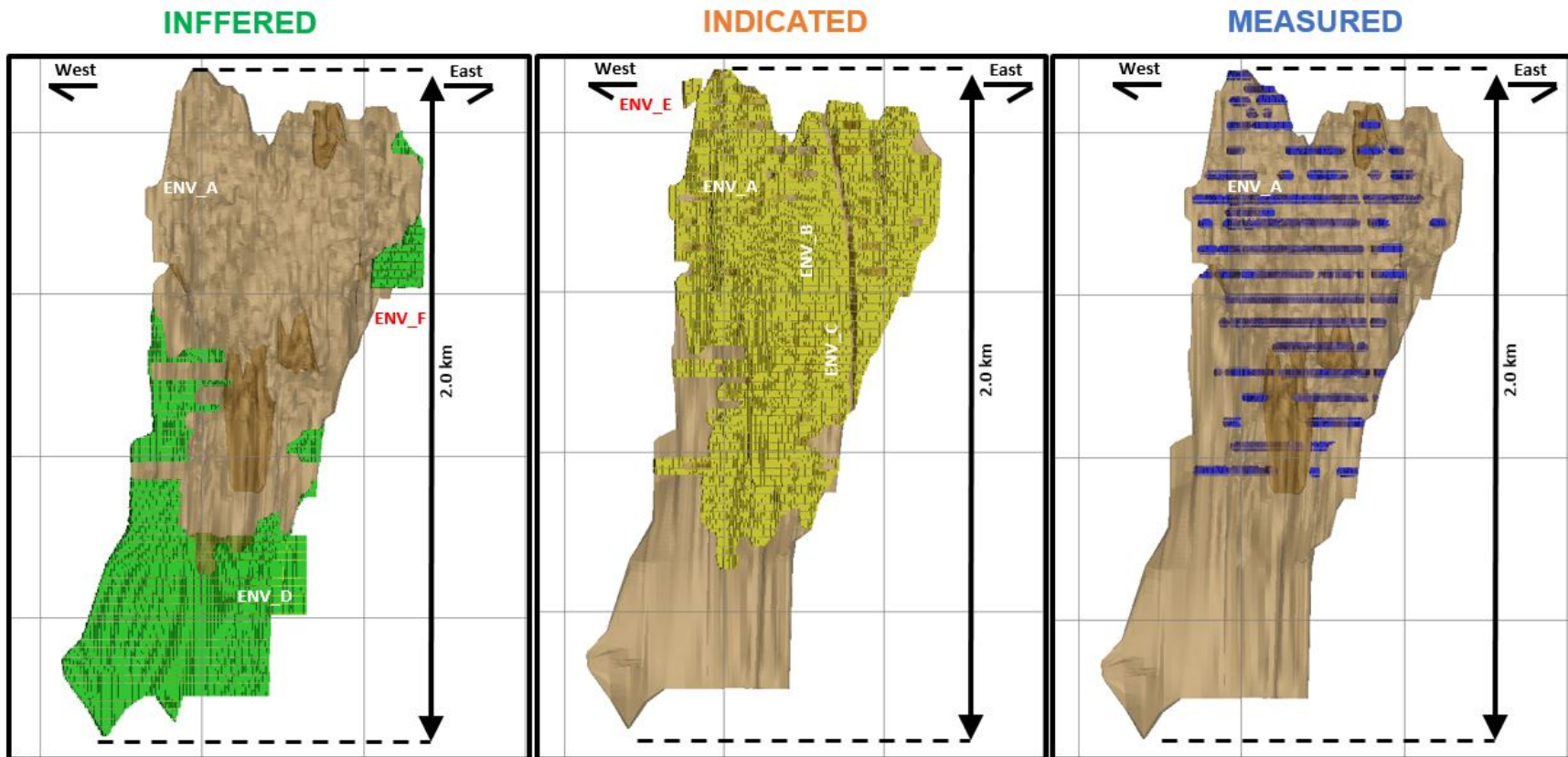

Figure 14-18: Composite longitudinal views, looking north, illustrating the distribution of the blocks classified as Inferred (left), Indicated (centre) and Measured (right) in the Horne 5 deposit



### 14.3 Mineral Resource Estimation

Given the nature of the data, the density of the processed data, the search ellipse criteria and the specific interpolation parameters, InnovExplo is of the opinion that the October 2017 MRE can be classified as Measured, Indicated and Inferred mineral resources. The October 2017 MRE is compliant with CIM standards and guidelines for reporting mineral resources and reserves. The mineral resources were estimated using different NSR cut-offs and a minimum width of 7.0 m (true width). The selected NSR cut-off of 55 \$/t allowed the mineral potential of the deposit to be outlined for an underground mining option.

The estimation of the NSR cut-off was based on the parameters presented in Table 14-25 in Section 14.1.13.

A volumetric analysis of the October 2017 MRE was carried out by using a constraining surface based on the block model boundaries and applying the 3D solid of the mining voids in order to calculate the volume of any mineralized material contained within the block model while excluding the mining void volumes.

Table 14-23 displays the results of the current In Situ<sup>1</sup> Mineral Resource Estimate for the Horne 5 deposit defined as six mineralized envelopes: ENV\_A, ENV\_B, ENV\_C, ENV\_D, ENV\_E and ENV\_F. The main mineralized envelope (ENV\_A) includes six high-grade gold zones, one high-grade copper-bearing zone, one high-grade zinc-bearing zone and three high-grade silver-bearing zones. Figure 14-7 presents the sensitivity of the NSR blocks at cut-offs ranging from 40 \$/t to 100 \$/t. InnovExplo estimates that the Horne 5 deposit contains Measured resources of 9,259,600 tonnes at 2.59 g/t AuEq (gold equivalent) for a total of 769,885 oz AuEq, Indicated resources of 81,855,200 tonnes at 2.56 g/t AuEq for a total of 6,731,443 oz AuEq, and Inferred resources of 21,500,400 tonnes at 2.51 g/t AuEq for a total of 1,735,711 oz AuEq. The detailed results of the October 2017 MRE by zones are presented overall and by zones in Table 14-26 and Table 14-27 respectively. A simplified sensitivity summary is compiled in the Table 14-28.

---

<sup>1</sup> The term “in situ” is used to represent the grade and metal content of the mineral resources in place without taking recovery factors into account.



Table 14-26: Horne 5 deposit mineral resource estimate at a \$55 NSR cut-off and sensitivity at other cut-off scenarios

Resource Class	Cut-off (NSR CAD)	Tonnes	Au Equivalent g/t	Au g/t	Ag g/t	Cu %	Zn %	Contained Au EQ (oz)	Contained Au (oz)	Contained Ag (oz)	Contained Cu (lbs)	Contained Zn (lbs)
Measured	> 40	11,295,000	2.36	1.44	15.47	0.17	0.74	857,012	521,228	5,619,321	42,567,041	184,997,718
	> 45	10,587,300	2.44	1.48	15.70	0.18	0.77	829,086	505,093	5,343,345	41,037,191	179,988,141
	> 50	9,905,800	2.51	1.53	15.94	0.18	0.80	799,860	487,890	5,078,063	39,522,686	174,476,064
	> 55	9,259,600	2.59	1.58	16.20	0.19	0.83	769,885	470,260	4,824,260	37,979,096	168,455,401
	> 60	8,569,500	2.67	1.63	16.49	0.19	0.85	735,502	450,062	4,542,801	36,208,863	161,347,275
	> 65	7,888,800	2.76	1.69	16.75	0.20	0.88	699,180	428,636	4,248,210	34,404,148	153,722,023
	> 70	7,289,400	2.84	1.74	16.96	0.20	0.91	665,038	408,900	3,974,790	32,752,763	145,898,462
	> 75	6,636,400	2.93	1.81	17.19	0.21	0.93	625,567	386,246	3,668,002	30,834,498	136,518,976
	> 80	6,066,500	3.02	1.87	17.39	0.22	0.96	589,191	365,343	3,392,094	28,954,428	128,079,740
	> 85	5,506,500	3.11	1.94	17.54	0.22	0.98	551,469	343,782	3,105,303	27,055,589	119,071,077
	> 90	4,972,400	3.21	2.02	17.66	0.23	1.00	513,640	322,352	2,823,953	25,202,021	109,565,101
	> 95	4,464,100	3.32	2.10	17.81	0.24	1.02	475,883	300,776	2,555,815	23,290,380	100,235,209
> 100	4,002,800	3.42	2.18	17.91	0.24	1.04	440,051	280,020	2,304,575	21,560,327	91,433,206	
Indicated	> 40	100,079,200	2.34	1.41	14.01	0.17	0.80	7,516,801	4,532,657	45,089,274	366,769,580	1,760,468,381
	> 45	94,154,600	2.41	1.45	14.24	0.17	0.83	7,282,542	4,395,171	43,106,440	354,089,787	1,714,677,409
	> 50	88,023,400	2.48	1.50	14.48	0.18	0.86	7,018,589	4,239,238	40,980,055	340,196,566	1,661,340,965
	> 55	81,855,200	2.56	1.55	14.74	0.18	0.89	6,731,443	4,070,385	38,796,042	325,387,951	1,599,297,906
	> 60	75,636,900	2.64	1.60	15.02	0.19	0.92	6,420,483	3,887,031	36,527,505	309,897,734	1,529,542,731
	> 65	69,633,700	2.72	1.65	15.31	0.19	0.95	6,099,083	3,698,471	34,282,928	294,104,323	1,453,978,546
	> 70	63,679,600	2.81	1.71	15.61	0.20	0.98	5,759,290	3,501,463	31,954,709	277,542,890	1,370,166,920
	> 75	57,902,400	2.91	1.77	15.91	0.20	1.00	5,409,159	3,300,591	29,620,177	260,527,138	1,280,014,146
	> 80	52,272,000	3.00	1.84	16.19	0.21	1.03	5,047,836	3,095,689	27,200,511	243,645,625	1,182,552,848
	> 85	47,102,100	3.10	1.91	16.44	0.22	1.05	4,698,039	2,896,804	24,897,139	227,544,521	1,087,483,674
	> 90	42,135,200	3.21	1.99	16.69	0.23	1.07	4,344,842	2,696,670	22,606,910	211,250,765	990,146,755
	> 95	37,488,300	3.32	2.07	16.91	0.24	1.08	3,998,411	2,500,643	20,378,702	195,332,454	893,862,282
> 100	33,209,700	3.43	2.16	17.12	0.25	1.09	3,664,651	2,311,001	18,281,755	180,311,500	800,315,812	
Measured + Indicated	> 40	111,374,200	2.34	1.41	14.16	0.17	0.79	8,373,813	5,053,885	50,708,595	409,336,621	1,945,466,099
	> 45	104,742,000	2.41	1.46	14.39	0.17	0.82	8,111,627	4,900,265	48,449,785	395,126,977	1,894,665,549
	> 50	97,929,200	2.48	1.50	14.63	0.18	0.85	7,818,449	4,727,128	46,058,118	379,719,252	1,835,817,030
	> 55	91,114,800	2.56	1.55	14.89	0.18	0.88	7,501,328	4,540,644	43,620,302	363,367,048	1,767,753,307
	> 60	84,206,300	2.64	1.60	15.17	0.19	0.91	7,155,985	4,337,093	41,070,306	346,106,597	1,690,890,007
	> 65	77,522,400	2.73	1.66	15.46	0.19	0.94	6,798,263	4,127,107	38,531,138	328,508,471	1,607,700,569
	> 70	70,969,100	2.82	1.71	15.75	0.20	0.97	6,424,329	3,910,364	35,929,500	310,295,652	1,516,065,382
	> 75	64,538,800	2.91	1.78	16.04	0.20	1.00	6,034,726	3,686,838	33,288,179	291,361,637	1,416,533,121
	> 80	58,338,500	3.01	1.85	16.31	0.21	1.02	5,637,026	3,461,033	30,592,605	272,600,053	1,310,632,588
	> 85	52,608,600	3.10	1.92	16.56	0.22	1.04	5,249,507	3,240,586	28,002,442	254,600,109	1,206,554,752
	> 90	47,107,600	3.21	1.99	16.79	0.23	1.06	4,858,482	3,019,022	25,430,863	236,452,786	1,099,711,856
	> 95	41,952,400	3.32	2.08	17.00	0.24	1.07	4,474,294	2,801,420	22,934,517	218,622,834	994,097,491
> 100	37,212,500	3.43	2.17	17.21	0.25	1.09	4,104,702	2,591,021	20,586,330	201,871,827	891,749,018	
Inferred	> 40	28,386,900	2.23	1.27	20.44	0.19	0.64	2,035,421	1,154,682	18,655,138	116,764,431	402,335,288
	> 45	25,969,500	2.32	1.32	21.33	0.19	0.67	1,938,636	1,101,683	17,805,226	110,143,710	383,109,560
	> 50	23,650,400	2.42	1.38	22.18	0.20	0.69	1,837,420	1,049,216	16,867,668	103,285,386	360,197,977
	> 55	21,500,400	2.51	1.44	23.04	0.20	0.71	1,735,711	996,727	15,925,446	96,262,726	337,246,544
	> 60	19,460,800	2.61	1.51	23.96	0.21	0.73	1,632,009	942,832	14,991,606	89,172,592	313,629,993
	> 65	17,417,100	2.72	1.58	24.97	0.21	0.75	1,520,945	885,068	13,981,146	81,231,774	289,487,365
	> 70	15,276,200	2.85	1.67	26.10	0.21	0.78	1,397,313	822,339	12,820,831	71,875,340	262,746,898
	> 75	13,410,600	2.98	1.77	27.18	0.22	0.80	1,283,093	764,065	11,718,924	64,283,415	236,178,158
	> 80	11,788,700	3.11	1.87	28.18	0.22	0.82	1,178,076	709,266	10,681,568	57,938,673	211,945,688
	> 85	10,133,600	3.27	1.99	29.32	0.23	0.83	1,064,972	649,817	9,552,110	51,199,787	186,324,231
	> 90	8,499,800	3.47	2.15	30.25	0.24	0.85	947,161	588,173	8,265,590	44,787,434	159,656,491
	> 95	7,200,100	3.67	2.32	30.81	0.25	0.86	848,697	537,934	7,131,834	39,716,151	136,131,579
> 100	6,069,300	3.89	2.51	31.50	0.26	0.86	759,455	490,659	6,146,037	35,372,960	115,459,745	

## Notes:

1. The effective date of the resource estimate is July 25, 2017. The Independent and QP for the Mineral Resource Estimate as required by National Instrument 43-101 is Carl Pelletier, P. Geo., B.Sc., employee of InnovExplo Inc.
2. Mineral resources are not mineral reserves and do not have demonstrated economic viability.
3. While the results are presented undiluted and in situ, the reported mineral resources are considered by the QP to have reasonable prospects for economic extraction.
4. These estimates include six low-grade gold-bearing mineralized envelopes.
5. The main low-grade gold-bearing mineralized envelope includes six high-grade gold-bearing zones, one high-grade copper-bearing zone, one high grade zinc-bearing zone, and three high-grade silver-bearing zones. Note that these high-grade zones may overlap each other.
6. Resources were compiled at NSR cut-offs of \$40, \$45, \$50, \$55, \$60, \$65, \$70, \$75, \$80, \$85, \$90, \$95 and \$100 per tonne for sensitivity purposes.
7. The official base case resource is reported at a 55 \$/t NSR cut-off.
8. The appropriate NSR cut-off will vary depending on prevailing economic and operational parameters to be determined.
9. NSR estimates are based on the following assumptions: Exchange rate of 1.28 CAD/1.00 USD; Metal prices as follows: gold 1,300 USD/oz, silver 19.50 USD/oz, copper 2.90 USD/lb, zinc 1.10 USD/lb (inspired from a long-term analyst consensus price forecast study); Net recoveries are variable in function of grade of each commodity. Smelting cost (including transportation) of 6.52 \$/t (based on the Mining Cost Service, as well as a non-public smelter contract obtained from one of the proposed destinations and talks with transport providers).
10. Gold equivalent calculations assume these same metal prices.
11. Inferred mineral resources are separate from Indicated mineral resources.
12. The quantity and grade of reported Inferred mineral resources are uncertain in nature and there has not been sufficient work to define these Inferred mineral resources as Indicated or Measured mineral resources. It is uncertain if further work will result in upgrading them to an Indicated or Measured mineral resource category.
13. The mineral resource was estimated using Geovia GEMS 6.8. The estimate is based on 5,980 DDH (483,254 m) of which 4,141 cut mineralized zones for a total of 178,150 m of core within these zones. For silver, the estimate also uses the results of an exhaustive metallurgical test comprising 2,112 DDH assayed for silver over a total length of 75,540 m. A minimum true thickness of 7.0 m was applied, using the grade of the adjacent material when assayed, or a value of zero when not assayed. Only the silver interpolation in the Inferred resources does not use the material when not assayed.
14. The estimate database also contains 14,799 channel samples for a total of 23,791 m from historically sampled drifts. Channel sample data was only used for distance to composite criterion for resource classification purposes.
15. 91% of density values were estimated using historical iron assay drill hole data and Falco density data for an average of 3.41 g/cm<sup>3</sup>. The interpolation method uses three passes for the ENV\_A and HG\_A to HG\_F zones. 8% of the density values were fixed at 2.88 g/cm<sup>3</sup> for ENV\_B to ENV\_E due to the scarcity of the data. 2.88 g/cm<sup>3</sup> represents the median of the available data. 1% of density values were fixed at 2.67 g/cm<sup>3</sup> for ENV\_F due to the scarcity of the data and to adequately characterize this quartz-rich zone.
16. Compositing was done on drill hole sections falling within the mineralized zones (composite = 3.0 m). Tails shorter than 0.75 m were not generated.
17. Resources were evaluated from drill holes using an ID<sup>2</sup> interpolation method in a block model (block size = 5 x 5 x 5 m).
18. High-grade capping was done on raw assay data and established on a per zone basis for gold (Au g/t): (HG\_A: 35; HG\_B: 35; HG\_C: 25; HG\_D: 35; HG\_E: 25; HG\_F: 35; ENV\_A: 35; ENV\_B: 25; ENV\_C: 25; ENV\_D: 20; ENV\_E: 35; ENV\_F: 25) and for silver (Ag g/t): SG\_HG:100; HG\_D: 165; HG\_F: 165; ENV\_A\_SG\_Low: 110; ENV\_B: 100; ENV\_C: 100; ENV\_D: 100. Capping grade selection is supported by statistical analysis. No capping was applied to the Cu and Zn data based on statistical analysis.
19. The reported mineral resources are categorized as Measured, Indicated and Inferred. The Inferred category is only defined within the areas where blocks were interpolated during pass 1 or pass 2 in areas where continuity is sufficient to avoid isolated blocks. The Indicated category is only defined by blocks interpolated in areas where the maximum distance to the closest drill hole composite is less than 25 m for blocks interpolated in passes 1 and 2. The Measured category is only defined by blocks classified as Indicated and within sufficient proximity to sampled drifts (<15 m). The average distance to the nearest composite is 6.97 m for the Measured mineral resources, 10.01 m for the Indicated resources and 40.10 m for the Inferred mineral resources.
20. Tonnage estimates were rounded to the nearest hundred tonnes. Any discrepancies in the totals are due to rounding effects. Rounding practice follows the recommendations set forth in Form 43-101F1.
21. CIM definitions and guidelines were followed in estimating mineral resources.
22. InnovExplo is not aware of any known environmental, permitting, legal, title-related, taxation, socio-political, marketing or other relevant issue that could materially affect the mineral resource estimate, other than the third party approvals previously mentioned.
23. Metal contained in ounces (troy) = metric tonnes x grade / 31.10348. Calculations used metric units (metres, tonnes and g/t). Metal contents are presented in ounces and pounds.

Table 14-27: Horne 5 deposit mineral resource estimate by zone at a \$55 NSR cut-off

Resource Class	Cut-off (NSR CAD)	Tonnes (Mt)	Au Equivalent g/t	Au (g/t)	Ag (g/t)	Cu (%)	Zn (%)	Contained Au EQ (Moz)	Contained Au (Moz)	Contained Ag (Moz)	Contained Cu (Mlbs)	Contained Zn (Mlbs)
Measured	ENV_A	5,368,470	2.14	1.28	15.90	0.15	0.89	370,057	220,503	2,744,389	18,007,687	104,932,419
	ENV_B	0	-	0.00	0.00	0.00	0.00	0	0	0	0	0
	ENV_C	0	-	0.00	0.00	0.00	0.00	0	0	0	0	0
	ENV_D	0	-	0.00	0.00	0.00	0.00	0	0	0	0	0
	ENV_E	0	-	0.00	0.00	0.00	0.00	0	0	0	0	0
	ENV_F	0	-	0.00	0.00	0.00	0.00	0	0	0	0	0
	HG_A	1,280,731	2.86	1.85	18.13	0.13	1.13	117,692	76,359	746,352	3,743,089	31,877,752
	HG_B	2,021,227	2.72	1.86	16.72	0.29	0.56	176,912	121,129	1,086,664	12,718,856	25,069,353
	HG_C	231,411	3.45	2.93	8.62	0.24	0.24	25,663	21,776	64,153	1,223,596	1,235,754
	HG_D	166,023	4.11	2.68	21.28	0.33	1.43	21,926	14,287	113,573	1,211,670	5,224,554
	HG_E	195,653	3.09	2.63	11.05	0.25	0.02	19,438	16,570	69,518	1,088,076	102,578
	HG_F	0	-	0.00	0.00	0.00	0.00	0	0	0	0	0
Indicated	ENV_A	52,691,969	2.17	1.25	15.13	0.15	1.00	3,670,062	2,116,667	25,633,359	176,683,211	1,165,328,072
	ENV_B	347,760	1.91	1.81	0.00	0.07	0.02	21,304	20,225	0	574,565	167,554
	ENV_C	213,480	2.29	2.19	0.00	0.07	0.05	15,712	15,010	0	324,944	214,891
	ENV_D	0	-	0.00	0.00	0.00	0.00	0	0	0	0	0
	ENV_E	149,760	2.67	1.82	0.00	0.24	1.09	12,833	8,760	0	791,794	3,592,556
	ENV_F	0	-	0.00	0.00	0.00	0.00	0	0	0	0	0
	HG_A	8,918,723	2.73	1.88	15.42	0.12	0.96	784,211	538,170	4,421,752	23,272,088	188,015,580
	HG_B	13,047,698	2.70	1.90	14.76	0.27	0.53	1,132,272	797,158	6,191,506	78,041,224	153,316,389
	HG_C	2,864,884	3.02	2.47	8.82	0.23	0.29	278,013	227,710	812,579	14,790,730	18,561,903
	HG_D	2,715,824	4.49	3.19	16.71	0.41	1.13	391,664	278,147	1,459,232	24,704,001	67,462,645
	HG_E	902,862	2.90	2.34	9.44	0.31	0.13	84,105	67,971	274,112	6,192,072	2,590,121
	HG_F	0	-	0.00	0.00	0.00	0.00	0	0	0	0	0
Inferred	ENV_A	16,950,546	2.04	1.08	22.61	0.19	0.80	1,111,170	587,412	12,322,287	70,746,174	300,819,520
	ENV_B	0	-	0.00	0.00	0.00	0.00	0	0	0	0	0
	ENV_C	0	-	0.00	0.00	0.00	0.00	0	0	0	0	0
	ENV_D	1,713,945	2.21	1.90	3.50	0.12	0.24	121,731	104,638	192,887	4,428,560	9,130,302
	ENV_E	0	-	0.00	0.00	0.00	0.00	0	0	0	0	0
	ENV_F	65,927	2.05	2.00	0.00	0.04	0.00	4,342	4,242	0	60,113	158
	HG_A	0	-	0.00	0.00	0.00	0.00	0	0	0	0	0
	HG_B	0	-	0.00	0.00	0.00	0.00	0	0	0	0	0
	HG_C	0	-	0.00	0.00	0.00	0.00	0	0	0	0	0
	HG_D	0	-	0.00	0.00	0.00	0.00	0	0	0	0	0
	HG_E	0	-	0.00	0.00	0.00	0.00	0	0	0	0	0
	HG_F	2,769,331	4.55	3.37	38.29	0.34	0.45	404,693	300,426	3,409,410	21,025,427	27,268,156

Table 14-28: Horne 5 deposit mineral resource estimate cut-off NSR sensitivity for gold equivalent

Cut-off	Measured			Indicated			Measured + Indicated			Inferred		
	Tonnage	Grade	Ounces	Tonnage	Grade	Ounces	Tonnage	Grade	Ounces	Tonnage	Grade	Ounces
40	11,295,000	2.36	857,012	100,079,200	2.34	7,516,801	111,374,200	2.34	8,373,813	28,386,900	2.23	2,035,421
45	10,587,300	2.44	829,086	94,154,600	2.41	7,282,542	104,742,000	2.41	8,111,627	25,969,500	2.32	1,938,636
50	9,905,800	2.51	799,860	88,023,400	2.48	7,018,589	97,929,200	2.48	7,818,449	23,650,400	2.42	1,837,420
<b>55</b>	<b>9,259,600</b>	<b>2.59</b>	<b>769,885</b>	<b>81,855,200</b>	<b>2.56</b>	<b>6,731,443</b>	<b>91,114,800</b>	<b>2.56</b>	<b>7,501,328</b>	<b>21,500,400</b>	<b>2.51</b>	<b>1,735,711</b>
60	8,569,500	2.67	735,502	75,636,900	2.64	6,420,483	84,206,300	2.64	7,155,985	19,460,800	2.61	1,632,009
65	7,888,800	2.76	699,180	69,633,700	2.72	6,099,083	77,522,400	2.73	6,798,263	17,417,100	2.72	1,520,945
70	7,289,400	2.84	665,038	63,679,600	2.81	5,759,290	70,969,100	2.82	6,424,329	15,276,200	2.85	1,397,313
75	6,636,400	2.93	625,567	57,902,400	2.91	5,409,159	64,538,800	2.91	6,034,726	13,410,600	2.98	1,283,093
80	6,066,500	3.02	589,191	52,272,000	3.00	5,047,836	58,338,500	3.01	5,637,026	11,788,700	3.11	1,178,076
85	5,506,500	3.11	551,469	47,102,100	3.10	4,698,039	52,608,600	3.10	5,249,507	10,133,600	3.27	1,064,972
90	4,972,400	3.21	513,640	42,135,200	3.21	4,344,842	47,107,600	3.21	4,858,482	8,499,800	3.47	947,161
95	4,464,100	3.32	475,883	37,488,300	3.32	3,998,411	41,952,400	3.32	4,474,294	7,200,100	3.67	848,697
100	4,002,800	3.42	440,051	33,209,700	3.43	3,664,651	37,212,500	3.43	4,104,702	6,069,300	3.89	759,455

---

#### 14.4 Mineral Resource Estimate Evolution

The overall October 2017 Measured + Indicated mineral resources represent a 5.7% increase in AuEq ounces compared to the November 2016 MRE. The 2017 Inferred mineral resources represent a 1.5% increase in total AuEq ounces compared to the November 2016 MRE.

The major difference with the previous estimate is the update of the metal prices and exchange rate. Figure 14-19 show waterfall charts of the changes since the previous estimate. This graph shows the impact, positive or negative, of the major changes to the block model from the previous estimate (left column) to the October 2017 MRE (right column). Figure 14-20 provides a longitudinal view of the November 2016 MRE and the October 2017 MRE with a NSR value above 55 \$/t (Measured, Indicated and Inferred).

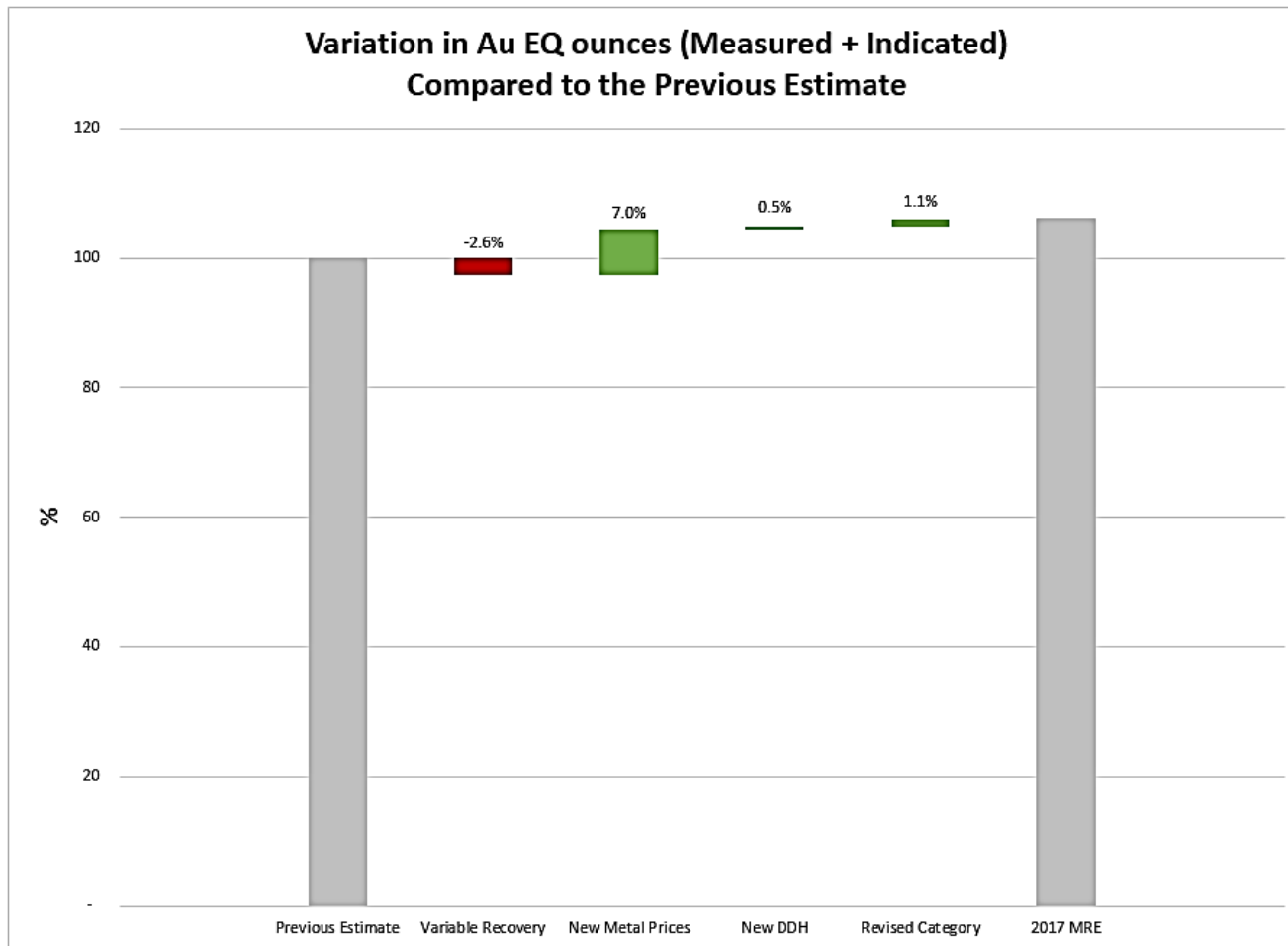

Figure 14-19: Waterfall chart of the changes since the November 2016 MRE

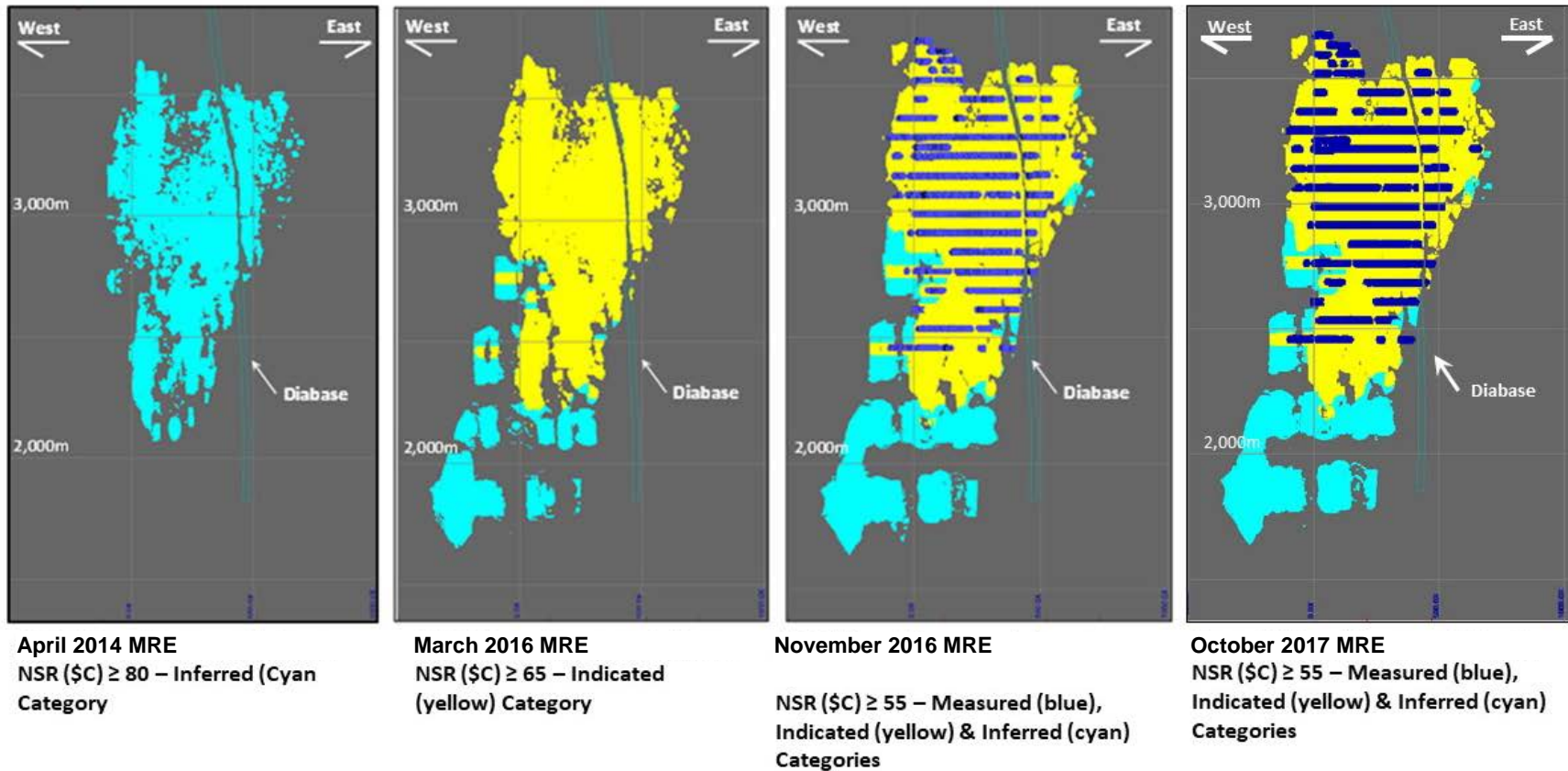

Figure 14-20: Longitudinal view comparing blocks for the November 2016 MRE and the October 2017 MRE



## 15. MINERAL RESERVE ESTIMATES

The mineral reserves estimate (Table 15-3) for the Horne 5 Project was prepared by Mr. Patrick Frenette, Eng., consultant with InnovExplo, and is dated effective as of August 26, 2017. The mineral reserves estimate stated herein is consistent with the CIM Standards on mineral resources and mineral reserves and is suitable for public reporting. As such, the mineral reserves are based on Measured and Indicated mineral resources, and do not include any Inferred mineral resources. Measured and Indicated mineral resources are inclusive of Proven and Probable reserves.

The FS LOM plans and mineral reserves estimate were developed from the previous November 2016 MRE and do not consider the October 2017 MRE. Updated metal prices, exchange rates and recovery equations from the October 2017 MRE were used to calculate the cashflows for the reserve estimate. As of the date of this Report, the QP has not identified any risks, legal, political, or environmental factors that would materially affect potential development of the mineral reserves (see Section 15.1).

### 15.1 Factors that May Affect the Mineral Reserves

Areas of uncertainty that may materially impact the mineral reserve estimates include the following:

- Licenses with third parties;
- Commodity prices, market conditions and foreign exchange rate assumptions;
- Cut-off NSR estimations;
- Capital and operating cost assumptions;
- Geological complexity and resource block modelling;
- Stope stability, dilution and mining recovery factors;
- Metallurgical recoveries and contaminants;
- Rock mechanics (geotechnical) constraints and the ability to maintain constant underground access to all working areas.

These mineral reserve estimates are based on the November 2016 MRE and not the October 2017 MRE.

## 15.2 Underground Estimates

Geological resources from the November 2016 MRE were used as the basis for estimating the mineable tonnage considered in the mine plan. This MRE is summarized and available in Chapter 6.

The geological block model was the primary input in the Deswik Shape Optimizer (“DSO”). A Deswik software application was used to generate individual stope shapes from the block model using the following parameters:

- Cut-off grade value: \$55 NSR;
- Sublevel interval and stope dimensions using parameters presented in Table 15-1;
- Mining dilution: not included in MSO;
- Minimum slope wall angle: 55°.

Table 15-1: Stope dimension parameters – DSO inputs

Depth	Type of Stope	Height (m)	Width (m)	Minimum Thickness (m)	Maximum Thickness (m)
710 m	Primary / Secondary	25	20	5.4	25
750 m to 1,310 m	Primary / Secondary	40	20	5.4	25
1,340 m to 1,760 m	Primary	30	20	5.4	16
	Secondary	30	16	5.4	24
1,800 m to 1,880 m (western portion)	Primary	30	20	5.4	16
	Secondary	30	16	5.4	24
1,800 m to 1,880 m (eastern portion)	Pillar less	30	16	5.4	16
1,910 m and below	Pillar less	30	16	5.4	16

The following recovery and dilution factors were used to determine the tonnage and grade included in the mine plan:

- Dilution: variable (see Section 15.3);
- Mining recovery: 95% to account for tonnage lost in stope;
- Sill recovery: a recovery factor was established to account for difficulty in mining the high-stress sill pillars. The recovery for each sill pillar is shown in Table 15-2. These values are different than the ones presented by Golder in Section 16.2.4 because it has been evaluated that the change in the mining sequence, after the study was done, would help resolve part of the challenges. It is important to understand that all tonnes associated with sill pillars could be at risk because of stability issues.



In addition, associated capitalized development and construction costs were considered to determine whether a stope is worth mining. These economic trade-off studies were conducted for a series of stopes and/or entire levels. In some cases, for rock mechanics purposes, stopes below the cut-off grade have been added in the mining sequence.

Table 15-2: Sill pillar recovery

Level	Recovery
1340	80%
1490	80%
1640	80%
1790	80%

### 15.3 Dilution Factor Calculation

Internal dilution was assumed when running the DSO software and external dilution related to waste, mineralized material and backfill was added after, based on the location of each stope.

For most stopes, it was assumed that dilution-causing material will come from within the mineralized envelope, except at the extremities of the deposit and in cases where adjacent stopes have been backfilled. The following criteria applied to the assessment of dilution:

- Dilution is expected to come from a 0.5 m layer of material around the stope;
- Development in a mineralized zone stops 1.0 m before reaching the hanging wall contact;
- Blasting practices will leave 1.0 m of mineralization on both hanging wall and footwall so that the 0.5 m of dilution will be in mineralized material with the same NSR value as the mineralized zone;
- Failure along backfilled stopes is expected to be 0.5 m with a NSR value of 0 \$/t;
- No dilution is assumed for the floor of the stope;
- Backfill density is set at 2.13 t/m<sup>3</sup> for dilution calculations.

Under these assumptions, the dilution is calculated independently for each stope based on the proportion of its walls and roof in contact with backfill relative to the mine plan and the geometry of the stopes. For example, the worst-case scenario is three of the four walls and the entire roof in contact with backfill. Depending on the stope geometry, a western or eastern wall or the roof of a stope can only be partially in contact with backfill.

In summary, the external dilution is estimated to be 2.3% for the entire Orebody. The mining recovery factor was set at 95% to account for mineralized material left in the margins of the deposit in each block.

## 15.4 NSR Cut-off calculation

NSR cut-off calculations are given in Section 14.1.13.

## 15.5 Statement of Mineral Reserves

Table 15-3: Statement of mineral reserves

Category	Tonnes (Mt)	NSR (\$)	Au (g/t)	Ag (g/t)	Cu (%)	Zn (%)
Proven	8.4	91.72	1.41	15.75	0.17	0.75
Probable	72.5	92.56	1.44	13.98	0.17	0.78
Proven + Probable	80.9	92.41	1.44	14.14	0.17	0.77

Notes:

1. The QP for the mineral reserve estimate is Mr. Patrick Frenette, Eng. from InnovExplo.
2. Mineral reserves have an effective date of August 26, 2017.
3. Estimated from the previous November 2016 MRE and does not consider the October 2017 MRE. Updated metal prices, exchange rates and recovery equations from the October 2017 MRE were used to calculate cashflows used to support the reserve estimate at 2.15 USD/lb Cu, 1.00 USD/lb Zn, 1,300 USD/oz Au and 18.50 USD/oz Ag, using an exchange rate of 1.30 CAD:USD, cut-off NSR value of 55 \$/t.
4. Mineral reserve tonnage and mined metal have been rounded to reflect the accuracy of the estimate; numbers may not add due to rounding.
5. Mineral reserves presented include both internal and external dilution along with mining recovery. The external dilution is estimated to be 2.3%. The mining recovery factor was set at 95% to account for mineralized material left in the margins of the deposit in each block.

## 16. MINING METHODS

*Pursuant to an agreement between Falco and a Third Party, Falco owns rights to the minerals located below 200 metres from the surface of mining concession CM-156PTB, where the Horne 5 deposit is located. Falco also owns certain surface rights surrounding the Quemont No. 2 shaft located on mining concession CM-243. Under the agreement, ownership of the mining concessions remains with the Third Party.*

*In order to access the Horne 5 Project, Falco must obtain one or more licenses from the Third Party, which may not be unreasonably withheld, but which may be subject to conditions that the Third Party may require in its sole discretion. These conditions may include the provision of a performance bond or other assurance to the Third Party and the indemnification of the Third Party by Falco. The agreement with the Third Party stipulates, among other things, that a license shall be subject to reasonable conditions which may include, among other things, that activities at Horne 5 will be subordinated to the current use of the surface lands and subject to priority, as established in such party's sole discretion, over such activities. Any license may provide for, among other things, access to and the right to use the infrastructure owned by the Third Party, including the Quemont No. 2 shaft (located on mining concession CM-243 held by such Third Party) and some specific underground infrastructure in the former Quemont and Horne mines.*

*Furthermore, Falco will have to acquire a number of rights of ways or other surface rights in order to construct the TMF and associated pipelines.*

*While Falco believes that it should be able to timely obtain the licenses from the Third Party and to acquire the required rights of way and other surface rights, there can be no assurance that any such license, rights of way or surface rights will be granted, or if granted will be on terms acceptable to Falco and in a timely manner.*

*Falco also notes that the timeline of activities described in this Report, and the estimated timing proposed for commencement and completion of such activities, is subject at all times to matters that are not within the exclusive control of Falco. These factors include the ability to obtain, and to obtain on terms acceptable to Falco, financing, governmental and other Third Party approvals, licenses, rights of way and surface rights (as described in this Chapter 16 and in Chapters 18 and 20).*

*Although Falco believes that it has taken reasonable measures to ensure proper title to its assets, there is no guarantee that title to any of assets will not be challenged or impugned.*

*The foregoing disclaimer hereby qualifies in its entirety the disclosure contained in this Chapter 16 of this Report.*

## 16.1 Introduction

The mine design outlined in this study consists of an underground mining operation to provide approximately 15,500 tpd average over the LOM. The mine life is estimated at approximately 15 years with a preproduction period of 3.5 years for dewatering the old workings and the construction of new underground infrastructure.

Given that the Horne 5 deposit lies below the operating Horne smelter, surface access to the mineralized zones must be located at a distance to avoid interfering with the facility in accordance with the Third Party agreement outlined in Chapter 4. Additionally, the upper portion of the Horne 5 deposit intersects old production levels of the historical Horne mine over a vertical range of approximately 300 m above Level 990. To ensure stability over this range, the mine plan leaves a minimum pillar of 15 m between the historical Horne mine stopes and the new planned stopes.

Prior to establishing the Horne 5 deposit, the old excavations surrounding the mining area must be dewatered. The Horne 5 Mining Complex is surrounded by the historical Horne mine, Quemont mine, Chadbourne mine, Joliet mine and Donalda mine, which are all inter-connected. Connections between these mines have been established based on available historical data and were all flooded following their closures. The dewatering of the Horne 5 Project will take about two years from day one of pumping activity.

The Horne 5 Project can benefit from some of the old underground workings. It is important to note that the historical Quemont No. 2 shaft is to be rehabilitated and deepened to a final depth of 1,910 m, largely eliminating the costs and time associated with shaft sinking. The underground workings will then be accessed using the historical Quemont No. 2 shaft. The shaft will be connected to the Horne 5 Mining Complex by several new levels:

- Levels L322, L790 and L1190 during Phase 1;
- Level L1880 during Phase 2 once the Quemont No. 2 shaft is deepened to its final depth of 1,910 m.

Sublevels will be accessible via a ramp located closer to the ore deposit. Once blasted, mineralized material will be moved through a system of rock breakers and orepasses to the crushers located at the bottom of each mine phase:

- Two crushers for the production of Phase 1;
- One crusher for the production of Phase 2.

The crushed material will then be transported over a distance of 600 m by conveyors to a silo near the shaft where the material will then be loaded into skips for hoisting to the surface. These loading stations are located on levels L1190 for Phase 1 and L1880 for Phase 2. In the case of the levels located under the Phase 2 loading (L1940 to L2060), the ore will be hauled by trucks to level L1910 to access the ore handling system facilities.

The mining method for the Project is the transverse long hole stoping method, with some areas being mined with the longitudinal mining retreat method, uppers or pillarless. To ensure rock mass stability, stopes will be mined in a primary-secondary sequence whereby primary stopes will be backfilled prior to the extraction of secondary stopes. Then secondary stopes will be backfilled as well. From level L1790 to level L1880, the pillarless method will apply for some stopes and entirely from level L1910 to level L2060.

The proposed mine plan for the Horne 5 Project is divided into two production phases characterized by their point of access to the mineralized zones, as illustrated in Figure 16-3.

Phase 1, with 53% of the total tonnage considered in the mining sequence, corresponds to the upper part of the mine accessed via the Quemont No. 2 shaft. This shaft will be rehabilitated and used for production and services. Levels L710 to L1310 (depth of 710 m to 1310 m) will be mined in Phase 1. Delaying further rehabilitation of the shaft will shorten construction time while ensuring sufficient production before proceeding with Phase 2.

In Phase 2, the Quemont No. 2 shaft will be deepened to its final depth of approximately 1,910 m. This will provide access to the remaining 43% of the deposit. Levels L1940 to L2060, representing about 3% of the deposit, will be hauled by trucks.

The remaining 4% of the production is provided by the development activities.

## 16.2 Rock Engineering

### 16.2.1 Considerations

The assessments completed for this section are based on the following provided by InnovExplo:

- Existing openings – February 24, 2016;
- Mining sequence and stope layout – August 8, 2017;
- Level plans (including infrastructure location) – August 14, 2017;
- Geology model – July 7, 2016.

The Horne 5 mine is located under the historical Horne mine at depths of approximately 950 m to 2,060 m and is adjacent to the historical Horne mine at depths of approximately 685 m to 950 m. The available data for the FS consisted of historical drill hole data, historical underground mapping data (down to 1,850 m depth below ground surface), and new diamond drilled core from the 2015 exploration program, including geotechnical data on selected intervals.

Due to the proximity of the historical Horne mine workings, historical diamond drill holes, rock mass quality and planned mining depths, the following items have been identified as being relevant for the rock engineering aspects of the Horne 5 Project:

- Impact of mining induced stresses and seismicity:
  - Stress damage – Mining is currently planned down to a depth of 2,060 m. As mining progresses from the shallower areas, i.e., approximately 710 m to 1,500 m, to the deeper areas, i.e., below approximately 1,500 m, stress damage is anticipated to occur around excavations as a result of an increase in stress magnitudes. The following items are impacted by the increase of stress magnitude with depth: stope size, stope sequence, sill pillar stability, rib pillar stability, impact of geological structures on mining, ground support, and stope blast hole stability/squeezing.
  - Potential for local rockbursts – The hard brittle nature of the rock mass and the deep mining conditions increase the likelihood of local rockbursts, i.e. strainbursts. The mining sequence has been designed to reduce the hazard of local rockbursts and dynamic ground support was accounted for.
  - Potential for larger instabilities:
    - Sill pillars – Due to the size and depth of the deposit, as well as the need to have multiple mining horizons to meet production requirements, sill pillars are planned to be created during mining. Operational challenges are expected during mining of the sill pillars, in particular mining in highly stressed ground. Sill pillar’ stability has been assessed, options recommended for their extraction and considered for the mine plan development.
    - Converging mining front creating rib pillars (diminishing pillar) – Due to the size of the deposit, as well as the need to have multiple mining fronts to meet production requirements, one converging mining front is to be created during mining in Phase 1. Operational challenges are expected due to a highly stressed volume of rock created as the two mining fronts converge. The mining sequence was developed to reduce stress interaction between the mining fronts.
    - Dikes – The hard brittle nature of the rock mass and the deep mining conditions resulting in large mining-induced stresses increase the likelihood of dike related seismicity. In particular, the north-south oriented sub-vertical diabase dike that crosses the mineralization on the east side of the deposit needs attention; the dike’s stability has been assessed and mitigation measures accounted for in the mining sequence.

- Faults – Similar to the dike above, the hard brittle nature of the rock mass and the deep mining conditions resulting in large mining-induced stresses increase the likelihood of fault related seismicity. Potential faults were identified from historical plans, which will have to be used for planning during detailed design and construction. Fault locations will need to be confirmed once underground mining is started due to the difficulty in assessing fault characteristics and rock bridges from current drill holes.
- Primary stope re-entry protocol recommendations – The potential for micro-seismic and seismic events at the mine is high. The main driver for seismic events is stress changes induced by mining. The occurrence and magnitude of seismic events is assumed to increase with depth and the largest events are estimated to be associated with sill pillars, converging mining fronts, diabase dikes, and faults. Recommendations have been provided on re-entry times when mining primary stopes.
- In Phase 2, as well as in sill pillars and Phase 1 converging fronts, blast hole stability may become a challenge. Procedures should be developed during detailed design and operation to deal with stuck drill rods or collapsed stope blast holes. Drilling directions may need to change such that the holes are drilled in the direction or closer to the direction of the major principal stress or a curtain of blast holes drilled to protect blasting patterns.
- Impact of historical mining:
  - Barrier pillar between Horne 5 and the historical Horne mine workings – The upper part of the Horne 5 Mining Complex (between levels L710 and L950) will be located near the mined-out historical Horne mine. A pillar of rock separates the main mined-out historical Horne mine from the new mining below. Stress fracturing through the core of this 'barrier' pillar during mining, as well as secondary faults and non-grouted drill holes intersecting the barrier pillar, may act as conduits for water inflow between the historical Horne mine and the Horne 5 developments. The mining sequence has been designed to reduce the potential for stress fracturing in the barrier pillar. Also, a 15-m stand-off distance between the new and historical mine workings is planned to be maintained. A higher binder content of 5% in the paste backfill, resulting in higher backfill strength, is also considered for the stopes within 65 m of historical workings. The historical Horne mine openings between levels L474 and L1310 will also be backfilled with paste backfill prior to mining.
  - Historical diamond drill hole – There is the potential for new excavations to intersect diamond drill holes connected to a water source such as a historical stope. When excavating in the vicinity of historical diamond drill holes, a procedure needs to be developed and measures adopted to deal with potential water inflows from historical drill holes. This is an operational aspect that will need to be developed once work moves underground.



- Near surface crown pillar stability – Near surface crown pillars have been identified at the Horne and Quemont mines, and at other peripheral historical mines that have a direct hydraulic connection with Quemont and Horne mines. An empirical stability assessment of those crown pillars has been completed based on available information. An investigation program is planned to be conducted and the stability of the crown pillars will be further assessed. Near surface crown pillars found to be potentially unstable will need to be addressed prior to dewatering. The objective is to secure, monitor and/or backfill crown pillars that are potentially unstable.

## 16.2.2 Rock Mass Characterization

### In Situ Stress

No stress measurements have been conducted in the Horne 5 deposit or within the Horne Block. Therefore, stress data from the region stated in Arjang (1996), Corthesy (1997), and Maloney et al. (2006) provided an estimate on the local in situ stress regime. While regional data was used, it is important to note that because the Horne 5 Mining Complex is in a fault bound block of rock, i.e., bound by the Horne Creek Fault and Andesite Fault, the stresses local to Horne 5 could be different compared to those in the region.

Based on the closest stress measurement to the Horne 5 Project (Ansil mine – Golder 2016a) the major principal stress has been assumed to be trending NE (045 degrees) and the minor principal stress vertical and equal to the weight of material above. The assumed magnitudes are based on the Maloney et al. (2006) for depths below 600 m.

Parametric assessments were completed to evaluate the impact of principal stress orientation on the results of selected rock mechanics assessments. The two stress fields considered were the major principal stress trending at 045° as stated above, and the major principal stress trending at 095°. As a reference, the orebody strike is oriented at approximately 108°.

### Rock Mass Parameters

Stress-induced failure of the rock will be a challenge at Horne 5. Therefore, effort was put into determining and refining the strength of the key rock units. A summary of rock strength testing and interpretation is provided in Golder (2016b). The failure type has been determined for each test: intact failure (not involving healed discontinuity); combined failure (involving both failure through intact rock and along healed discontinuities); and discrete failure (controlled by a previously healed discontinuity). Testing data was assessed according to the failure type. In addition to the laboratory testing done during the PEA, FS level laboratory testing was completed for the following rock types: massive sulphide (“MS”); semi-massive sulphide (“SMS”); rhyolite (“RHY”); diorite (“DIO”); diabase (“DIA”); and andesite (“AND”). Three test types were completed: 1) triaxial compressive strength (“TCS”); 2) uniaxial compressive strength (“UCS”); and 3) Brazilian indirect tensile strength (“BTS”). The number of valid tests for each rock unit is outlined in Table 16-1.



Table 16-1: Summary of number of laboratory rock strength tests<sup>(1)</sup>

Rock Type	PEA			Feasibility Study		
	UCS	BTS	TCS	UCS	BTS	TCS
Massive Sulphide (MS)	5	2	0	4	5	10
Semi-Massive Sulphide (SMS)	5	2	0	7	5	8
Rhyolite (RHY)	6	2	0	5	7	15
Diorite (DIO)	2	1	0	5	5	11
Diabase Dike (DIA)	4	2	0	3	5	8
Andesite (AND)	1	1	0	5	5	0
<b>Total</b>	<b>23</b>	<b>10</b>	<b>0</b>	<b>29</b>	<b>32</b>	<b>52</b>

<sup>(1)</sup> Includes intact, combined and discrete breaks.

Intact rock strength parameters and elastic properties (Young’s modulus and Poisson’s ratio) were assessed. In general, the rock types were found to be hard, stiff, strong, and brittle. Unconfined compressive strength values are presented in Table 16-2 for each rock type. Young’s modulus and Poisson’s ratio values are presented in Table 16-3 for each rock type and a summary of the Hoek-Brown parameters is provided in Table 16-4.

Table 16-2: Summary of unconfined compressive strength per rock type (for intact failure type)

Rock Type	Unconfined Compressive Strength (UCS)			
	Number of tests	Minimum (MPa)	Maximum (MPa)	Average (MPa)
Massive Sulphide (MS)	9	148	189	<b>168</b>
Semi-Massive Sulphide (SMS)	6	137	192	<b>157</b>
Rhyolite (RHY)	6	136	330	<b>205</b>
Diorite (DIO)	5	156	321	<b>247</b>
Diabase Dike (DIA)	5	165	383	<b>258</b>
Andesite (AND)	5	98	387	<b>221</b>

Table 16-3: Summary of Young's Modulus and Poisson's Ratio per rock type

Rock Type	Young's Modulus				Poisson's Ratio			
	Number of tests	Minimum (GPa)	Maximum (GPa)	Average (GPa)	Number of tests	Minimum	Maximum	Average
Massive Sulphide (MS)	6	91	222	<b>145</b>	5	0.19	0.33	<b>0.23</b>
Semi-Massive Sulphide (SMS)	7	97	242	<b>144</b>	7	0.15	0.26	<b>0.21</b>
Rhyolite (RHY)	5	81	113	<b>94</b>	5	0.10	0.30	<b>0.22</b>
Diorite (DIO)	5	104	114	<b>110</b>	5	0.24	0.30	<b>0.27</b>
Diabase Dike (DIA)	3	92	115	<b>106</b>	3	0.25	0.31	<b>0.28</b>
Andesite (AND)	5	91	120	<b>103</b>	5	0.18	0.29	<b>0.25</b>

Table 16-4: Summary of mean Hoek-Brown strength parameters per rock type (for intact failure type)

Rock Type	Number of tests <sup>(1)</sup>			$\sigma_{ci}$ (MPa)	$m_i$	$R^2$ <sup>(2)</sup>
	UCS	BTS	TCS			
Massive Sulphide (MS)	9	7	8	177	19	0.85
Semi-Massive Sulphide (SMS)	6	7	4	148	10	0.90
Rhyolite (RHY)	6	9	6	234	13	0.69
Diorite (DIO)	5	6	5	286	20	0.84
Diabase Dike (DIA)	5	7	4	260	20	0.79
Andesite <sup>(3)</sup> (AND)	5	5	0	222	12	0.25

<sup>(1)</sup> Only intact failure type tests (i.e. not involving healed discontinuities).

<sup>(2)</sup> Coefficient of determination of the fit.

<sup>(3)</sup> No triaxial testing has been done in andesite. Hoek Brown parameters were obtained by fitting only UCS and BTS data, thus resulting in a low  $R^2$  value.

The testing results appear reliable based on the observed scatter (as shown in Golder 2016b) and consistency in the test results. The testing data for AND are limited, i.e., no triaxial data, but at this point, no further laboratory testing is recommended due to the location of the AND relative to mining and placement of infrastructure.

The rocks tested are hard and stiff (Young's modulus >90 GPa and up to 240 GPa). The upper end testing result values are for the MS and SMS units. In the Horne 5 deposit, these rocks appear silicified. The high silica content and high density of the MS and SMS result in a material that could be similar to a ceramic, which is high silicate and high modulus material. The high strength of the rocks coupled with the high modulus values have the potential to generate a brittle rock mass response and high energy release when subjected to mining induced stress changes. Due to the high modulus values, specimens were sent to a second laboratory for confirmation. The high modulus results were confirmed (Golder 2016b).

## Rock Mass Classification

The collection of geotechnical data from the 2015 exploration drill holes provided the input parameters for the classification of the rock mass quality according to the RQD (Deere and Deere 1989),  $RMR_{76}$  (Bieniawski, 1976) and Q-System (Barton et al., 1974) rock mass rating systems. These input parameters included the following:

- RQD values – from geotechnical core logging data;
- Intact rock strength – from laboratory and point load testing data;
- Number of joint sets – from historic underground level mapping and oriented core logging data;
- Joint spacing – inferred from fracture frequency using geotechnical core logging data;
- Joint surface characterization – from geotechnical core logging data;
- Joint orientation – from oriented core data and historical underground mapping data;
- Groundwater – assumed dry conditions.

The RQD system, which considers only the fracturing of the rock, suggests that the rock mass units are classified as “Excellent” quality (Deere and Deere 1989). The  $RMR_{76}$  system, which considers Intact Rock Strength, RQD, joint spacing, joint surface conditions and groundwater conditions (assumed to be dry), suggests that the rock mass units are of “Good to Very Good” quality. The Q-system, which considers RQD, the number of joint sets, joint condition, joint water reduction factor, and stress reduction factor, suggests that the rock mass units are of “Fair to Good” quality (for a  $J_w/SRF$  ratio of 1.0). These quality indexes are not uncommon in the Canadian Shield, where the igneous rock is often both strong and moderately jointed. Overall, high rock mass strengths can be expected but these strengths can result in high stress conditions developing in the vicinity of excavations, which can in turn cause elastic strain to build-up, and possibly release energy suddenly. Details on the rock mass characterization at Horne 5 are provided in Golder (2016a, b).

## Major Structures

Primary major faults, i.e., these faults interpreted to be >1000 m, displayed on the historical Horne mine geology level plans and sections have been digitized, georeferenced and interpreted by InnovExplo to create a 3D lithostructural model of the Horne 5 Project area, detailed in Section 7.3.4. The following were identified as primary major faults:

- Horne Creek fault – The Horne Creek fault is interpreted in the 3D model as a discrete sub-vertical northeast-southwest to east-northeast-west-southwest striking structure. However, a zone of intense shearing with a thickness that varies between 50 m and 150 m is observed along the fault trace. The rock in the zone of shearing was observed from the 2015 diamond drill core to be mainly composed of silicified Strong to Very Strong (ISRM 1981) rocks with

intervals of 1-5 m of soft altered defects and shearing and alteration along sub-vertical joints. The Horne Creek fault will be crossed by long accesses between the Quemont No. 2 shaft and the Horne 5 deposit.

- Andesite fault – The Andesite fault is interpreted in the 3D model as a discrete sub-vertical east-west striking structure. However, a zone of intense shearing with a thickness that varies between 1 m and 10 m is observed along the fault trace. Limited core data is available to characterize the Andesite fault. The rock in the zone of shearing was observed from the limited 2015 diamond drill core to be composed of Very Strong (ISRM 1981) rocks presenting intervals of 0-0.5 m thickness of hard broken rock fragments without alteration. The Andesite will be located at the contact of the southern stopes in the eastern portion of Phase 2 mining.
- Strong fault – The Strong fault is interpreted as a corridor between 30 m and 50 m dipping south-southwest at approximately 70° between L1235 and L2170. No diamond drill core information is available to characterize this structure.
- “No name” fault – The “no name” fault is interpreted as a structure dipping east-southeast at approximately 45° between L817 and L1082. The diamond drill core from the only 2015 drill hole intersecting shows a zone of 0.5 m thickness of crushed rock at the interpreted structure location.

One hundred eleven (111) smaller fault structures within the Horne Block Sequence, referred to as secondary major faults, have also been digitized from historical plans and sections, georeferenced and interpreted by InnovExplo during the FS. These secondary major faults are mainly sub-vertical structures striking northeast and east-west to east-southeast-west-northwest. Twenty-four (24) structures dip at less than 80° along these two main orientations. A trace of these faults was observed in one third of the intersections of the 2015 diamond drill holes with the interpreted location in the 3D model of the faults suggesting that the fault could be undulating, offset or could include rock bridges. The 2015 diamond drill core suggests that the secondary major faults have a thickness generally less than 0.5 m.

The secondary major faults could possibly contribute to create a water pathway between the historical Horne mine and Horne 5 excavations. They could have an impact on local stope stability and potential for rockbursting, e.g., fault-slip, and should be used for planning during detailed design and construction. Primary and secondary major faults will need to be confirmed once underground, due to the difficulty in assessing character and rock bridges from current drill holes.

The location of the major primary faults is shown on Figure 16-1. An example of the traces of the secondary major faults on L774 is shown on Figure 16-2.

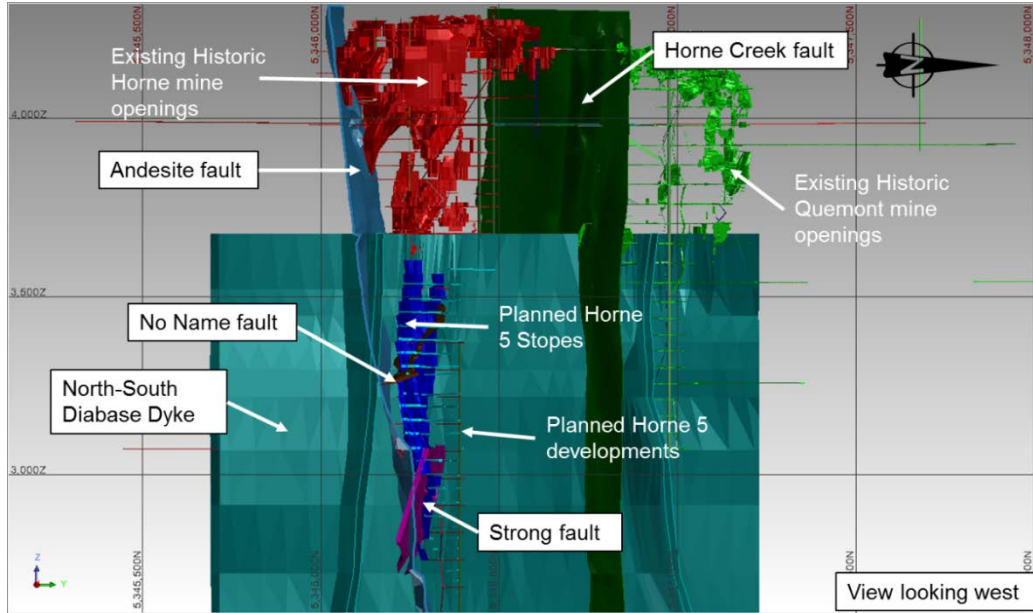

Figure 16-1: Location of the primary major faults – view looking west

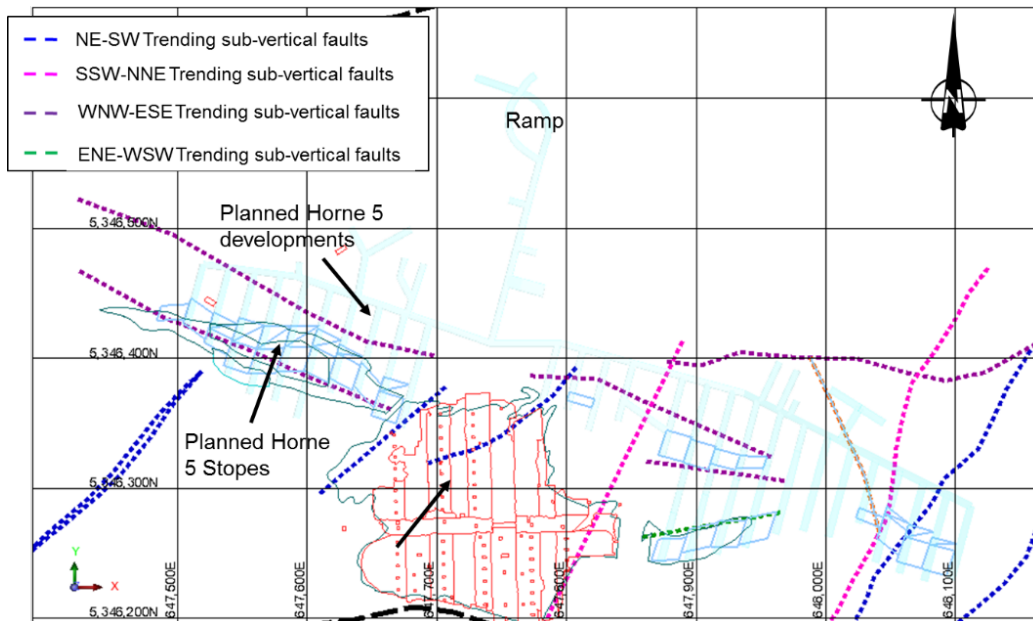

Figure 16-2: Plan view of secondary major faults intersections on typical Phase 1 level

## Rock Mass Jointing

Orientations of structures for the Horne 5 deposit are available from oriented core logging in the 2015 exploration drill holes and historical underground mapping. A total of 4,390 structures were oriented with core orientation, 311 structures and 107 faults (added from the PEA) from historical mapping were extracted from selected historical level plans (between mining depths of 774 m and 1,840 m). The oriented core logging data appears to be consistent with the historical underground mapping data reviewed.

Globally, the main sets appear consistent with the Horne 5 site's structural setting because the main joint sets and the major structures present similar orientations. For the FS, joint orientation bias was assessed using historical mapping data that was then compared to the orientated core logging data and interpretation from the PEA. The mapping data, taken in different drift orientations, suggests that a sub-vertical joint set striking north-northwest/south-southeast is not fully captured by the oriented core data.

The main global set orientations are:

- East-west to striking sub-vertical set: parallel to the Andesite fault orientation;
- Northeast-southwest to east-northeast-west-southwest striking sub-vertical set: parallel to the Horne Creek fault orientation;
- North-northwest/south-southeast striking sub-vertical set;
- Set dipping southwest at 48°;
- Set dipping southeast at 25°.

### 16.2.3 Proximity between New and Historical Mine Workings

During mining, there is potential for stress fracturing through the core of the barrier pillar between the Horne 5 and historical Horne mine workings. This may create a pathway for water into the Horne 5 developments. The mining sequence developed is anticipated to minimize the stress concentration in the stopes close to the historical Horne mine, thus reducing the hazard of water inflow into the Horne 5 developments.

A 15-m stand-off distance between the historical Horne mine and the Horne 5 stopes is planned in the current sequence. In addition, a higher binder content of 5% in the paste backfill, resulting in higher backfill strengths, has also been considered for the stopes within 65 m of historical workings. Approximately 54 stopes are located between 15 m and 65 m of the historical Horne mine, and will thus require higher binder content. The historical Horne mine openings between levels L474 and L1310 will also be backfilled with paste backfill prior to mining. When mining of Horne 5 stopes starts, the rock mass conditions of the barrier pillar as well as the fault locations and characteristics are to be confirmed. Based on those observations, there may be an opportunity to mine some stopes within the 15-m standoff distance and reduce the number of stopes requiring the higher binder content paste backfill.

#### 16.2.4 Near Surface Crown Pillars

The dewatering of the surrounding historical mines could impact the stability of near surface crown pillars of these historical mines. The location of the near surface crown pillars was identified for the Horne, Quemont, Chadbourne, Donalda and Joliet mines using the 3D model, developed by InnovExplo, of the existing historical mine openings developed during the FS according to the available historical plans and sections.

One hundred thirty-eight (138) crown pillars were identified within 100 m of ground surface: 96 at the Horne mine, 26 at the Quemont mine, 6 at the Chadbourne mine and 10 at the Donalda mine. No crown pillar was identified within 100 m from ground surface at the Joliet mine. No geotechnical drilling has been carried out to confirm the presence or assess the conditions or stability of the crown pillars at this point. The stability of identified near surface crown pillars needs to be further assessed before dewatering. Near surface crown pillars found to be potentially unstable, as a result of further study, will need to be addressed prior to dewatering. The potential unstable crown pillars will require securing, monitoring, and/or backfilling. Details on near surface crown pillar review is provided in Golder (2017a). The responsibility to ensure stability of near surface crown pillars remains with the Third Party owner of the mining infrastructure.

#### 16.2.5 Mining Sequence

Mining is planned in two phases: Phase 1 mining is from level L710 down to level L1310, and Phase 2 mining is from level L1340 down to level L2060 divided into four mining zones (A, B, C and D). The mining zones are shown on Figure 16-3. The mining sequence challenges associated with each mining zone are summarized below. Sill pillars are discussed separately in Section 16.2.7.



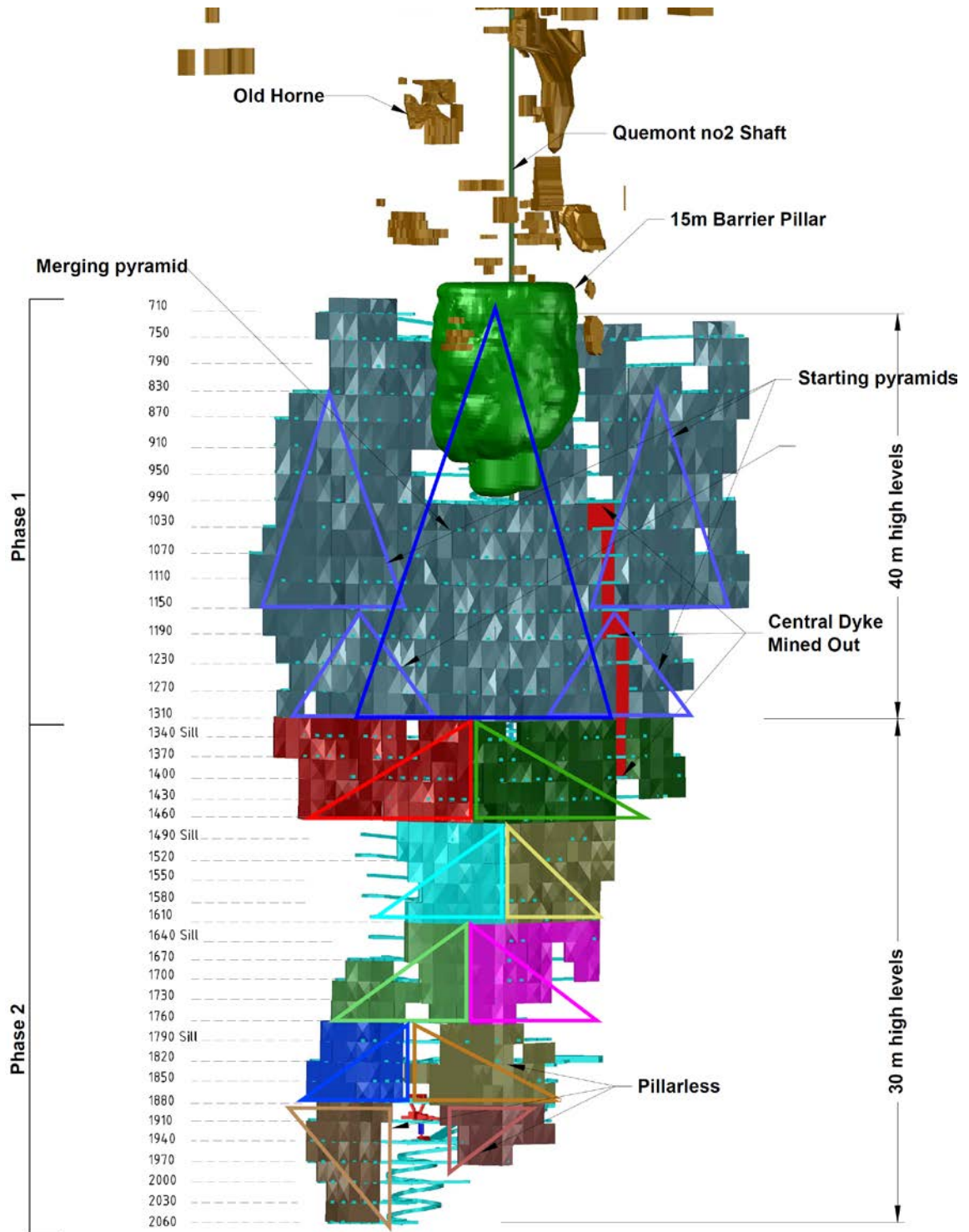

Figure 16-3: Mining zones – longitudinal section



- Phase 1 (Levels L710 – L1310): The main challenge with this mining zone is the development of adjacent mining fronts, the proximity to the historical Horne mine, and the north-south (“NS”) diabase dike location.
  - Mining of Phase 1 is initiated with four starter pyramids: two on L1310 and two on L1150. When the horizontal distance between the mining fronts is approximately 200 m, the progression of the two western starter pyramids is stopped, and the four starter pyramids are progressively merged. Mining fronts in Phase 1 will not converge simultaneously where stress interaction between the eastern and western fronts is expected.
  - Mining in Phase 1 will induce stress changes in the vicinity of the historical Horne mine. As stresses increase in the area, fracturing of the barrier pillar between the historical Horne mine and the Horne 5 stopes could create a hydraulic connection between the two mines. Furthermore, faults could contribute to create a water pathway between the historical Horne mine and Horne 5. A 15-m stand-off distance between new and historical mine workings is planned to be maintained. In the current mining sequence, the closest Horne 5 stopes to the historical Horne mine are excavated as the leading stopes of the merged Phase 1 pyramid. The mining sequence developed is anticipated to minimize the stress concentration in the stopes close to the historical Horne mine, but stopes in proximity of the historical Horne mine could still be developing high stresses locally. In addition, a higher binder content of 5% in the paste backfill resulting in higher backfill strengths has also been considered for the stopes within 65 m of historical workings to aid in increasing stability. The historical Horne mine openings between levels L474 and L1310 will also be backfilled with paste backfill prior to mining.
  - The NS diabase dike cuts through the Phase 1 mining zone. The two eastern starter pyramids are centered on the diabase dike. To avoid high stresses developing in the diabase dike and to avoid having to mine stopes in high stresses close to the dike, de-stressing of the area is planned. A de-stress slot of 5 m transverse, 40 m high and 20 m along strike on levels L1310 up to L1030 is planned. Therefore, the stopes abutting the dike are forecasted to be mined before the dike becomes highly stressed, limiting personnel exposure.
- Phase 2A (Levels L1340 – L1460): The main challenge with this mining zone is the location of the NS diabase dike. The diabase dike cuts through the Phase 2A mining zone. In the current mining sequence, mining progresses towards the dike. To avoid high stresses developing in the dike and to avoid having to mine stopes in high stresses close to the dike, de-stressing of the area is planned on levels L1400 up to L1340. This de-stressing activity will be done in sequence.

- Phase B (Levels L1490 – L1760): The main challenge with this mining zone is the NS diabase dike located in the eastern abutment. Due to its location, the dike has a thin pillar of hosting rock between it and the mining front. As mining progresses towards the dike, high stresses could develop between the dike and the progressing mining fronts. While the stiffness and strength of the materials are similar, there still could be a sufficient difference in these parameters potentially resulting in conditions causing larger (approximately 1 to 1.5 Nuttli Magnitude) seismic events. The planned mining sequence minimizes exposure to the lead stope. Increased re-entry time may be needed once stoping is within approximately 40 m of the abutment (end of the lateral stoping horizon).
- Phase 2C (Levels L1790 – L1880): The main challenge within this mining zone is the leading stopes being located in a high stress front. This area consists of a primary-secondary half chevron progressing to the west from the centre of the ore body and primary-primary half chevron progressing to the east. The lead stopes are expected to be mined in highly stressed ground. Increased re-entry time will be needed for the lead stopes.
- Phase 2D (Levels L1910 – L2060): The main challenge within this mining zone is the leading stopes being located in a high stress front. This area consists of a primary-primary full chevron progressing from top to bottom to mine in yielded ground. Based on current assessments, the lead stopes are expected to be mined in highly stressed ground. Increased re-entry time may be needed for the lead stopes. While the assessments suggest the ground may not be yielded, mining top down is considered more favourable than mining bottom up towards the sill pillar. Mining from level L1910 is planned to start when mining of Phase 2C mining zone (levels above L1910) is started 180 m laterally and 120 m vertically such that stress changes due to above mining minimally impact the top down mining.

The potential for micro-seismic and seismic events at the mine is high. The main driver for seismic events is stress changes induced by mining. The occurrence and magnitude of seismic events will increase with depth. Also, the larger events are likely to be associated with sill pillars, converging mining fronts, diabase dikes and faults. Stope re-entry time to manage seismic events is considered within the current mining sequence. Recommendations regarding re-entry time are provided below for the FS mine planning purposes.

- Standard re-entry time is suggested to be 12 hours (1 shift). The standard re-entry time is currently assumed to be applied only for primary stopes, after blasting of the upper portion of the stope, i.e., the “crown blast”. It is reasonable to assume that a re-entry time should be applied to the following for planning purposes:
  - Phase 1 stopes on levels L950 to L710: 15% of the time;
  - Phase 1 stopes on levels L1310 to L990: 25% of the time;
  - Phase 1 stopes close to small-scale faults: 40% of the time;
  - Converging mining front in Phase 1 on levels L1310 to L1150: 25% of the time;
  - Sill pillars: 90% of the time;
  - Phase 2 stopes: 100% of the time.

### 16.2.6 Slope Dimensions

The slope size was based on both 3D plastic numerical stress modelling (FLAC3D) and the Mathews’ method for open slope design, for both the Phase 1 and Phase 2 mining zones. In Phase 1, the main assessment criteria for the slope size was the yielded nature of the secondary stopes so that mining could occur in these stopes under de-stressed conditions. If the yielding criteria is not forecasted to be met, then the remaining capacity of the secondary stopes should be such that they can be expected to remain stable, i.e. sufficiently far from peak strength. In Phase 2, the main assessment criteria for the slope size was the yielded nature of the secondary stopes so that mining could occur in these stopes under de-stressed conditions. The slope size in Phase 2 was modified from Phase 1 to have shorter stopes, i.e., 30 m, and have smaller width and strike lengths based on empirical data from other deep operations. This smaller slope size was simulated to confirm whether yielded secondary conditions prevailed. In areas where the orebody is thinner, i.e., less than 50 m, in Phase 2, the secondary stopes are not forecasted to yield and the longitudinal open stoping with no secondary stopes (referred to as *pillarless*) is planned. The slope sizes for the FS are summarized by mining Phases in Table 16-5.

Table 16-5: Summary of slope dimensions

Phase	Depth from Surface (m)	Primary Stope Size <sup>(1)</sup>	Secondary Stope Size <sup>(1)</sup>
1	Levels L710 to L1310	25 W x 20 L x 40 H	25 W x 20 L x 40 H
2	Levels L1340 to L2060	16 W x 20 L x 30 H	24 W x 16 L x 30 H
2	Levels L1790 to L1880 (eastern half-chevron only) Levels L1910 to L2060	16 W x 16 L x 30 H	N/A ( <i>pillarless</i> mining)

<sup>(1)</sup> W = width (transverse dimension - hanging wall to footwall); L = strike length; and H = height.

### 16.2.7 Sill Pillars

Five sill pillars are created in the mining sequence. The sill pillars are planned to be extracted during the mining sequence, i.e. not temporarily left in place, and then mined at the end of mining. Sill pillars with the current mining sequence have not been explicitly simulated. The assessment presented herein is based on previous modelling results in which a different, but comparable, sequence had been simulated. The main assessment criterion for the sill pillar thickness was the yielded nature of the sill before mining. The sill pillars were ranked by perceived mining difficulty (based on the stress modelling results – yielded elements and stress magnitude). Based on this relative mining difficulty assessment, an ore recovery percent based on engineering judgement was assigned to each sill pillar to reflect operational challenges expected during mining of the sill, in particular, mining in highly stressed ground. The sill pillar thicknesses planned for the FS are summarized in Table 16-6 and each sill pillar is described from a rock mechanics perspective.

Table 16-6: Summary of sill pillar thicknesses

Sill Pillar Level	Sill Pillar Thickness	Estimated Recovery <sup>(1)</sup>	Comments
L1190	40 m	80%	40-m thick sill pillar created by the starter pyramids in the early stages of mining. A 100-m long sill pillar will be created between the western starter pyramids and a 300-m long sill pillar will be created between the eastern starter pyramids, as the starter pyramids are merged. Because of the thickness of the orebody at this elevation (2 to 3 stopes), the sill could yield. However, because the lower starter pyramids are only 4 levels high, stresses might not be high enough to cause yielding of the sill pillar, in which case a thinner sill could be planned for, with taller stopes at L1270. The taller stopes would be mined in two stages. Once the stopes are half mucked out, the top of the stope would be paste backfilled. Once the paste is cured, stope mucking would re-start. This approach limits stope wall exposure and minimizes stope wall instability.
L1340	30 m	70%	30-m thick sill pillar is forecasted to yield. Operational challenges due to mining in highly stressed ground (although potentially post-peak) are expected for the lead stopes to be mined at the sill pillar level.
L1490	30 m	80%	30-m thick sill pillar is forecasted to yield. Operational challenges due to mining in highly stressed ground (although potentially post-peak) are expected for the lead stopes to be mined at the sill pillar level.
L1640	30 m	50%	Sill pillar not forecasted to yield and highly stressed. This sill pillar will be a challenge to mine.
L1790	30 m	50%	Sill pillar not forecasted to yield and highly stressed. This sill pillar will be a challenge to mine.

<sup>(1)</sup> Recovery values shown in this table are meant to reflect the operational challenges from a rock mechanics perspective, during mining of the sills.

If one of the sill pillar is to be left in place, i.e. not mined, de-stressing or sill thickness re-design of the sill pillar should be considered to minimize rock engineering stability concerns.

### 16.2.8 Infrastructure Proximity Relative to Orebody

Fixed infrastructure location was assessed based on numerical stress modelling results for a previous mining sequence and previous infrastructure layout. The main assessment criteria were the loss of confinement and stress increases at the underground infrastructure location. Confinement was considered sufficient when the maximum principal stress at the infrastructure location remained above 5 MPa and the minimum principal stress remained above 2 MPa. Stress increases were also assessed relative to the strength of the intact rock.

Current infrastructure layout was not assessed with the actual mining sequence. Current infrastructure includes:

- Ventilation raises: West pair and East in Phase 1; West, East and Central in Phase 2;
- Ore passes: West and East;
- Ramp;
- Crushers: two at L1310 and one at L1880;
- Garage: at L1190;
- Haulage drifts.

Based on previous modelling results and general review of current infrastructure location, the following are observed:

- Ore passes:
  - The minimal distance between the ore pass West in Phase 1 and the orebody is 100 m (up to 130 m). In Phase 2, the minimal distance between the ore pass West and the orebody is 80 m (up to 170 m);
  - The minimal distance between the ore pass East in Phase 1 and the orebody is 75 m (up to 105 m). In Phase 2, the minimal distance between the ore pass East and the orebody is 75 m (up to 130 m);
  - The assessment criteria described above should be met for the ore passes. Localized loss of confinement may be experienced as mining progresses. The ore passes, due to the depth, may experience some stress damage and thus preferential wear during their life. In addition, if finger raises are present, these locations in the ore passes are prone to impact damage. The ore and waste passes should be kept full to limit their wear and damage due to impact loading. Depending on local stress conditions experienced when the ore passes are excavated, alternative locations or linings may be required.
- Ventilation raises:
  - In Phase 1, the minimal distance between the West ventilation raises and the orebody is 50 m (up to 70 m). The minimal distance between the East ventilation raise and the orebody is 40 m (up to 70 m);
  - In Phase 2, the minimal distance between the West ventilation raise and the orebody is 45 m (up to 100 m). The minimal distance between the East ventilation raise and the orebody is 45 m (up to 85 m). The minimal distance between the Central ventilation raise and the orebody is 150 m (up to 230 m);
  - The assessment criteria described above should be met for the ventilation raises. Localized loss of confinement may be experienced as mining progresses. Depending on local stress conditions experienced when the ventilation raises are excavated, alternative locations or linings may be required.

- The minimal distance between the ramp and the orebody is 80 m. The assessment criteria described above are forecasted to be met at this distance;
- The Phase 1 crushers are located at approximately 80 m from the orebody on L1310. The Phase 2 crusher is located at 80 m from the orebody on L1880. Principal stresses at the location of crushers are forecasted to decrease due to mining, but the confinement criterion should still be met;
- The Phase 1 garage is located on L1190. The garage is located sufficiently far away, i.e., more than 500 m away from the orebody, such that the principal stresses at the garage location should be minimally impacted by mining;
- Haulage drifts:
  - In general, haulage drifts are located at 23 m from the orebody (a constraint of the mining equipment used but sufficient from a rock engineering perspective). The assessment criteria described above are forecasted to be met at this distance;
  - To reduce development costs, haulage drifts on levels 1310 to 1030 are planned to be developed in the orebody. The main challenge related to developing haulage drifts in ore is the management of the stress increase around the drifts as the mining front approaches. From previous modelling results, stress-paths for drives located in ore and out of ore were compared to determine which drives within the ore were under similar stress paths as to those located out of the ore, as well as which drives within the ore were subjected to unfavourable stress paths. i.e., those that lost confining pressure while still maintaining or having increasing major principal stress. Haulage drifts stress paths should be reassessed as part of the detailed engineering phase with the current sequence. At this stage, increased ground support requirements have been accounted for in the drifts located in the ore.

The current infrastructure layout will be assessed during the detailed engineering.

### 16.2.9 Ground Support

The ground support needs were assessed for gravity driven wedges, stress damage around excavations and rockbursting conditions. The following ground support is planned for costing purposes and is based on the assessments performed and Golder's experience. The ground support needs should be reassessed when the rock mass conditions and behaviour are confirmed once underground access is available. Change of conditions should be monitored for and ground support modified accordingly. Due to the sulphide character of the deposit and the longevity required of some excavations, corrosion-resistant ground support and preventative rehabilitation need to be considered in some locations. Galvanized support has currently been considered for permanent excavations. Actual corrosion-resistant ground support requirements should be defined once the underground and corrosion environment is characterized.

## Developments

The ground support for development drives is outlined as follows (assuming a 4.5 m high by 5.4 m wide drift). Permanent openings should use corrosion-resistant support elements such as galvanized products, if appropriate for the corrosion conditions, or other products once corrosion conditions are confirmed. Temporary openings are assumed not to require corrosion-resistant support at this time – to be confirmed once underground. The roof of all developments should be arched.

- Ramp and permanent accesses (not highly stressed):
  - For depths from 0 m to 1,310 m:
    - Walls – 2.4 m long FS39 Split Sets to drift mid-height on a 1.2 m x 1.2 m spacing, with #6 gauge welded wire mesh (spacing of bolts should be adjusted to fit mesh size so that there are 4 mesh squares overlapping; increased spacing is not allowed);
    - Back – 2.4 m long, 20-mm diameter, fully resin grouted rebar on a 1.2 m x 1.2 m spacing, with spherical seats and #6 gauge welded wire mesh (spacing should be adjusted to fit mesh size so that there are 4 mesh squares overlapping; increased spacing is not allowed).
  - For depths below 1,310 m:
    - Walls – 2.4 m long FS46 Split Sets as close to the floor as possible on a 1.2 m x 1.2 m spacing, with #6 gauge welded wire mesh (spacing of bolts should be adjusted to fit mesh size so that there are 4 mesh squares overlapping; increased spacing is not allowed). Bolts should have #00 gauge mesh plates placed under the standard plates;
    - Back – 2.4 m long, 20-mm diameter, fully resin grouted rebar on a 1.2 m x 1.2 m spacing, with spherical seats and #6 gauge welded wire mesh (spacing should be adjusted to fit mesh size so that there are 4 mesh squares overlapping; increased spacing is not allowed). Bolts should have #00 gauge mesh plates placed under the standard domed plates.
- Haulage drifts in ore in Phase 1:
  - Walls and Back – First pass of in-cycle 50-mm fibre reinforced shotcrete then application of the ground support for mining depths below 1,310 m;
  - Face – Bolted and screened to within 1.5 m from the floor, with FS46 Split Sets on a 1.2 m x 1.2 m spacing and #6 gauge welded wire mesh (spacing should be adjusted to fit mesh size so that there are 4 mesh squares overlapping; increased spacing is not allowed). The support must be in place prior to drilling the next round.



- Rehabilitation support:
  - Walls and Back – First pass of in-cycle 50 mm to 100 mm fibre reinforced shotcrete followed by 2.4 m long, fully resin grouted 20-mm diameter rebar on a 1.2 m x 1.2 m spacing, with spherical seats and #4 gauge welded wire mesh (spacing should be adjusted to fit mesh size so that there are 4 mesh squares overlapping; increased spacing is not allowed), down to 0.3 m from floor and 4 m long, fully grouted 25 tonne cable bolts on a 1.2-m spacing, installed between the rebar. For costing and scheduling purposes, rehabilitation is expected to be required in the following locations:
    - Sill pillars: 50% of the time;
    - Rib Pillars: 30% of the time;
    - Phase 1: 10% of the time;
    - Haulage drifts in ore in Phase 1: 80-100% of the time;
    - Phase 2: 25% of the time.
- Drifting through paste backfill:
  - Walls and Back: In-cycle 2.4 m long FS39 Split Sets in back and to drift mid-height on a 1.2 m x 1.2 m spacing, with #6 gauge welded wire mesh (spacing should be adjusted to fit mesh size so that there are 4 mesh squares overlapping; increased spacing is not allowed) followed by one pass of 50 mm in-cycle fibre reinforced shotcrete down to the floor. In-cycle shotcrete may be required depending on backfill conditions.

Special ground support and drifting considerations will be needed for mining under highly stressed ground conditions, which need to be evaluated during detailed design and in the field on an ongoing basis. For planning purposes, 15% of the development meterage below 1,310 m depth, 100% of the drifts bounding sill pillars and the stopes adjacent to the NS diabase dike should be assumed to have the following ground support:

- Walls – 2.4 m long D-Bolt on a 1 m x 1 m spacing, with spherical seats and #4 gauge welded wire mesh down to the floor (spacing should be adjusted to fit mesh size so that there are 4 mesh squares overlapping; increased spacing is not allowed). Bolts should have #00 gauge plates placed under the standard domed plates;
- Backs – 2.4 m long D-Bolt on a 1 m x 1 m spacing with spherical seats and #4 gauge welded wire mesh down to the floor (spacing should be adjusted to fit mesh size so that there are 4 mesh squares overlapping). Bolts should have #00 gauge plates placed under the standard domed plates;
- Face – 50 mm in-cycle fibre reinforced shotcrete down the floor. Then bolted and screened to the floor with FS46 Split Sets on a 1.2 m x 1.2 m spacing with #6 gauge welded wire mesh (spacing should be adjusted to fit mesh size so that there are 4 mesh squares overlapping; increased spacing is not allowed). The support must be in place before drilling the next round.



Dynamic ground support design will need to be completed during detailed design and updated based on actually encountered ground conditions.

## Intersections

For intersections with inscribed circular diameter of  $\geq 7$  m (this limiting dimension is assumed for planning purposes), the following ground support is suggested:

- Primary support: Install development ground support as mentioned above;
- Secondary support:
  - Intersection should not be developed until the primary heading is a minimum of three rounds past the location where the intersection is created;
  - One line of trim slash is permitted while advancing to allow opening onto the intersection stringer. Open to a maximum of 4 m wide;
  - Secondary support, installed prior to creating the intersection, consists of:
    - 4 m long fully grouted 25 t cable bolts on a 2 m collar spacing. The cables can be replaced by Super Swellex in temporary intersections;
    - Secondary support is to be installed two rows into the drifts forming the intersection.

## Stopes

The main ground support for the primary and secondary stopes is paste backfill. Ground support elements, such as bolts, cables, surface support, etc., are currently not found to be required for the hanging walls of the stopes. The following support is planned during the development of the stopes:

- Overcut and undercut drifts:
  - Primary support: install ground support as per development support outlined above.
  - Back secondary support: 10 m long fully grouted 25 t cable bolts on a 2-m collar spacing. Note that this cable support could potentially be reduced during detailed design.
- Draw points:
  - Primary support: install ground support as per development support outlined above.
  - Brow secondary support: 4 m long fully grouted 25 t cable bolts on a 2-m toe spacing. Install at least three cables across a draw point brow. Cables connected via a #00 gauge welded wire mesh strap.

- Pillar nose secondary support: add #00 gauge welded wire mesh straps to the primary wall ground support as per mining depth outlined above, such that pillar noses are wrapped one round beyond the location of the pillar nose effectively wrapping the pillar nose.

### Ventilation Raises

The ventilation raises will be excavated by raise boring. Two ventilation raises will be used as emergency egresses and will be supported, while the other raises will be left unsupported. The ventilation raises will be supported using an Alimak. The following ground support is suggested. Fibre reinforced shotcrete is suggested to reduce atmospheric corrosion in the emergency egresses.

- For depths from 0 m to 1,424 m: 50-mm fibre reinforced shotcrete followed by 2.4 m long fully resin grouted rebar on a 1.2 m x 1.2 m spacing with spherical seats and #8 gauge welded wire mesh (spacing should be adjusted to fit mesh size so that there are 4 mesh squares overlapping; increased spacing is not allowed);
- For depths below 1,424 m: 75-mm fibre reinforced shotcrete followed by 2.4 m long fully resin grouted rebar on a 1.2 m x 1.2 m spacing with spherical seats and #6 gauge welded wire mesh (spacing should be adjusted to fit mesh size so that there are 4 mesh squares overlapping; increased spacing is not allowed).

### Quemont No. 2 Shaft

Quemont No. 2 shaft is rectangular and is already excavated up to a depth of approximately 1,200 m. Fully resin grouted rebar and mesh was initially recommended at the PEA for the rehabilitation of the shaft, but a concrete liner is considered for the FS, as a replacement of the mesh, to reduce rehabilitation time. The following ground support is recommended, considering a concrete liner:

- For depths from 0 m to 900 m: 1.8 m long, fully resin grouted rebar on a 1.4 m x 1.4 m spacing with spherical seats followed by the concrete liner of a minimum of 150-mm, with minimum concrete strength of 30 MPa at 28 days;
- For depths below 900 m: 2.4 m long, fully resin grouted rebar on a 1.2 m x 1.2 m spacing with spherical seats followed by the concrete liner of a minimum of 150-mm, with minimum concrete strength of 40 MPa at 28 days.

It should be noted that the concrete liner in the rectangular shaft will permit the installation of shaft steel on a standard surface, thus reducing field adjustment. The concrete strengths suggested above are intended for the support of the rock wedges. The design of the strength and thickness of the concrete liner will be completed at detailed design.

For the excavation of the shaft below current depth, i.e. 1,200 m deep, the above recommendations were used for costing purposes for the FS, but will change depending on the sinking approach or geometry adopted for the deepening of the shaft.

### Ore passes

- The ore passes are planned to be excavated by raise boring and thus will be unsupported. The ore passes, due to the depth, will experience stress damage and thus preferential wear during their life. In addition, if finger raises are present, these locations in the ore passes will be prone to impact damage. The ore and waste passes should be kept full to limit their wear and damage due to impact loading. Depending on local stress conditions experienced when the raises and passes are excavated, alternative locations or internal linings may be required.

### Crushers

Crushers Phase 1 (Level L1310):

- In cycle 75-mm fibre reinforced shotcrete followed by 2.4 m long fully resin grouted rebar on a 1.2 m x 1.2 m spacing down to 0.3 m from the floor, with spherical seats and #6 gauge welded wire mesh (spacing should be adjusted to fit mesh size so that there are 4 mesh squares overlapping; increased spacing is not allowed), and with 5 m long fully grouted 25-tonne cable bolts on a 1.2 m spacing, installed between the rebar.

Crusher Phase 2 (Level L1880):

- In cycle 75-mm fibre reinforced shotcrete followed by 2.4 m long fully resin grouted rebar on a 1.2 m x 1.2 m spacing down to 0.3 m from floor, with spherical seats and #6 gauge welded wire mesh (spacing should be adjusted to fit mesh size so that there is 4 mesh squares overlapping; increased spacing is not allowed), and with 8 m long fully grouted 25-tonne cable bolts on a 1.2 m spacing, installed between the rebar. Cables should be connected together with #00 gauge welded mesh straps longitudinally.

Detailed crusher ground support design should be completed during the detailed engineering stage and evaluated during construction based on as-built conditions.

### Garage (Level L1190)

- Walls – 1.8 m long fully resin grouted rebar on a 1.2 m x 1.2 m spacing down to 0.3 m from the floor, with spherical seats and #8 gauge welded wire mesh (spacing should be adjusted to fit mesh size so that there are 4 mesh squares overlapping; increased spacing is not allowed), and with 4 m long fully grouted 25-tonne cable bolts on a 1.2 m spacing, installed between the rebar.

- Back – 1.8 m long fully resin grouted rebar on a 1.2 m x 1.2 m spacing down to 0.3 m from the floor, with spherical seats and #8 gauge welded wire mesh (spacing should be adjusted to fit mesh size so that there are 4 mesh squares overlapping; increased spacing is not allowed), and with 10 m long fully grouted 25-tonne cable bolts on a 1.2 m spacing, installed between the rebar. Cables should be connected together with #00 gauge welded mesh straps longitudinally.

Detailed garage ground support design should be completed during the detailed engineering stage and evaluated during construction based on as-built conditions.

### 16.2.10 Backfill Strength Requirement

The following binder contents are planned for the paste backfill:

- At least 5% binder for the stopes within 65 m of the historical Horne mine workings. The goal is to achieve higher fill compressive strength and modulus within stopes in close proximity to the historical Horne mine workings, due to anticipated additional challenges with ground and groundwater conditions;
- 3.5% binder content to achieve at least 1 MPa compressive strength for the other stopes (primary and secondary stopes).

These values are for the overall stope volume and are provided so that the percentage of cement for operating expense (“OPEX”) calculations could be estimated. These values should be considered blended strength values accounting for the different required strengths for the stopes’ sill (plug), body and cap pours.

Blended compressive strength of 1 MPa was recommended based on Golder’s experience and based on the Mitchell et al. (1982) equation to meet at a minimum for design of free-standing backfill:

$$UCS_{design} = \frac{\gamma H}{1 + H/L} FoS$$

where  $\gamma$  = fill bulk unit weight (21.3 kN/m<sup>3</sup> considered); L = strike length of stope (m); H = total height of fill (m); FoS = factor of safety, for a safety factor of 3.0 for the stope dimensions considered in the FS.

Testing performed on paste backfill by URSTM (2017) suggests a linear relationship between UCS and Young’s Modulus (“E”). Data suggest that when the UCS value doubles, E also doubles. The paste backfill strength of 1 MPa is planned to capitalize on the modulus of the fill to limit stope closure and thus energy release.

The 5% binder content paste strength is planned to create a stiffer engineered pillar in stopes around the historical Horne workings with paste backfill of higher binder content, to account for uncertainty on historical stope geometry and backfilling conditions, diamond drill hole locations and fault locations that could impact stability of the pillar between the two mines.

### 16.2.11 Rock Mass Monitoring Needs

The main objective of the monitoring during the construction stage is to confirm the assumptions made during the FS, i.e., rock mass quality, anticipated stresses, stope stability, and failure mechanisms. Once production is started, the monitoring of the rock mass behaviour will help further confirm the design assumptions, but will also help to forecast potential instabilities and provide tactical information for making decisions related to the management of identified hazards through such actions as design changes.

The following items are planned to be implemented:

- Development of a Ground Control Management Plan (“GCMP”) at the planning and detailed design stage. This plan would be regularly updated and audited during the life of mine. The GCMP should be audited for both compliance and business risk.
- Development of a ground support implementation program especially for the dynamic ground support (rockburst) support package so that the ground support components are performing as needed (e.g., checking that the resin or grout strength is appropriate for the d-bolt performance desired – grout can be too strong resulting in poor dynamic ground support performance in some cases).
- Development of a quality assurance and quality control (“QA/QC”) program for ground support and paste backfill strength testing (e.g., using pull-tests on the ground support tendons and paste cylinders collected at stope pour points).
- Development of a stope stability database based on the Mathews’ method (Golder 1981).
- Installation, commissioning, and regular calibration of a micro-seismic system, including fibre optic hubs at each electrical sub-station. The system should be designed such that tactical decisions can be made using the data, e.g., identification of seismic sources, highly stressed volumes of rock, de-stressed volumes of rock, etc., and re-entry protocols developed. The system should have sufficient triaxial sensors so that moment tensors can be reliably determined.

- Systematic geological and geotechnical mapping. Mapping should start as soon as underground access is available. At a minimum feature type, orientation (dip and dip direction), and geological units should be systematically recorded. Fixed infrastructure should be mapped in detail so that actual structural conditions are recorded within the excavation and the design checked. As-built records containing actual encountered geology, jointing, faults, etc. and their locations within the excavation should be available for each massive excavation.
- Development of an instrumentation plan, which would include instruments such as SMART-cables, stress cells, InSAR, and Multi-Point Borehole Extensometers (“MPBXs”) and Trigger Action Response Plans (“TARPs”) in:
  - Surface crown pillars identified as being at risk;
  - Surface infrastructure such as the smelter;
  - Large infrastructure (e.g., crushers and garage);
  - Barrier pillar between the historical Horne mine and the Horne 5 developments;
  - Area of concern where the mining fronts are converging in Phase 1;
  - Drifts bounding sill pillars during sill recovery;
  - Haulage drifts in ore;
  - Instruments in Quemont No.2 shaft;
  - Instruments in areas of anticipated high stresses and thus stress damage.
- Stress measurements early during re-access to the mine (around 500 m depth), once the Horne 5 area is accessible at 1,000 m depth, and at 1,300 m, and 1,600 m depths thereafter. The need for stress measurements should also be assessed once underground access is made. Measurements may be needed at different depths than specified or for various purposes such as sill pillar stress determination.

### 16.3 Mine Hydrogeology

The hydrogeological conditions in the vicinity of the Quemont site were defined based on the fieldwork conducted during the summer of 2015 and the fall of 2016. The results of these investigations are summarized in Golder (2017b) and consist in the completion of a packer test profile (15 tests over 774 m length) and the implementation of nine observation wells at four different locations at the Quemont site. These observation wells were installed in the overburden and shallow bedrock.

Available surficial geology information (Veillette and al., 2003) shows bedrock outcropping over 25% of the study area. Where present, the overburden consists mainly of a low permeability silty-clay deposit. Silty-clay thickness can reach up to 30 m on the shore of Osisko North basin, as observed during the development of the Verglas pit in the early 2000s (Sopko and al. 2015).

Elsewhere at the Quemont site, the average silty-clay thickness is 8 m, based on borehole results. A glacial till layer is present under the silty-clay unit. The average till thickness is 2.3 m, based on borehole results. Hydraulic conductivity of the glacial till is between  $3 \times 10^{-6}$  m/s and  $1 \times 10^{-4}$  m/s, based on hydraulic tests performed in one observation well and two end tubing tests (Lefranc test).

Figure 16-4 presented below shows the distribution of hydraulic conductivity values with a depth measured during the profiling of the H5-15-06 borehole (15 tests over 774 m in length). The results presented in this figure show that in general, the hydraulic conductivity decreases with depth. The hydraulic conductivity measured in the first 130 m of bedrock is low (geometric mean of  $6 \times 10^{-8}$  m/s). Beyond 130 m deep, the hydraulic conductivity is very low (geometric mean of  $6 \times 10^{-10}$  m/s). The sector of the Horne Creek fault was investigated by Golder to gather hydrogeological data. Results did not show significant increase of hydraulic conductivity during testing. Finally, hydraulic conductivity test results from four observation wells installed in shallow bedrock (0-5 m) show a hydraulic conductivity between  $7 \times 10^{-7}$  m/s and  $1 \times 10^{-4}$  m/s.

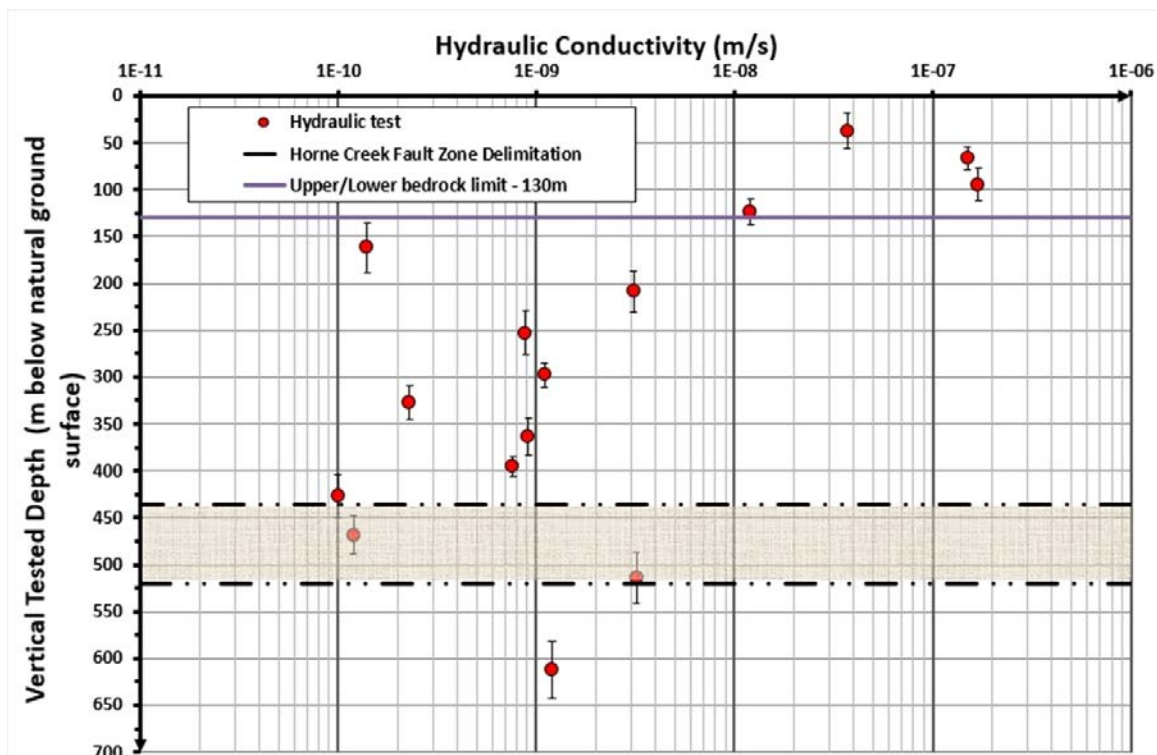

Figure 16-4: Hydraulic conductivity profile – borehole H5-15-06



To estimate the potential inflow of water into the underground workings, the groundwater flow was modelled using the software FEFLOW (Version 7.0), developed by the firm WASY Ltd. The model was developed at a regional scale (14 km x 10 km) and includes the overburden, bedrock and the existing workings of the Donalda, Joliet, Chadbourne, Quemont and Horne mines. The details of the groundwater flow model are summarized in the Golder (2017c) report. Bedrock was divided into three layers, based on the distribution of hydraulic conductivity with depths presented in Table 16-7. The till and silty-clay were the overburden unit considered in the model. The hydraulic conductivity of the till was defined based on the hydraulic test performed at the Quemont site, whereas the hydraulic conductivity of the silty-clay was defined based on values from mine sites in Abitibi. The historical workings were represented in the hydrogeological model as a simplification of the 3D mine model developed by InnovExplo. Each existing mine was represented as high permeability/high porosity solid having the same volume as estimated in Section 16.4.2, and the same interconnections as presented in Section 16.4.1.

**Table 16-7: Hydraulic conductivity value considered in the hydrogeological model**

Hydrogeological Unit	Hydraulic Conductivity Value (m/s)
Upper bedrock (0-5 m from top of bedrock)	$8 \times 10^{-7}$
Intermediate bedrock (5-130 m)	$1 \times 10^{-7}$
Deep bedrock (+ 130 m)	$1 \times 10^{-9}$
Till	$2 \times 10^{-5}$
Silty-clay	$1 \times 10^{-8}$

Based on the assumptions presented above, groundwater inflow, during preproduction and production dewatering into the historical Quemont and Horne mines, is estimated at 80 m<sup>3</sup>/h. The effects of the dewatering on the groundwater flow regime are discussed in Section 20.2.5.

### 16.3.1 Dewatering Flow Rate Estimate

Water pumped from underground is projected to come from three different sources:

- Water volume stored in flooded historical workings: Total of 11.83 Mm<sup>3</sup> (last estimation obtained from InnovExplo). The preproduction dewatering will include the pumping of 10.58 Mm<sup>3</sup> from the Horne, Quemont and Donalda mines. It is not planned to dewater Chadbourne and Joliet mines and an estimated volume of 0.18 Mm<sup>3</sup> is left in the historical Horne mine after the preproduction dewatering. About 1.55 Mm<sup>3</sup> of water pumped from the deepest portion of the Horne is planned to be temporarily stored in the dewatered workings of Quemont. This water stored at Quemont will be reclaimed during the production phase.



- Groundwater inflow into the historical mine workings: Groundwater inflow in the mine workings is estimated at 80 m<sup>3</sup>/h. Groundwater inflow into Donalda mine is not expected to have a significant impact on the dewatering pumping demand as this mine will be isolated by a hydraulic plug during the first few months of dewatering (Section 16.4.1). Water bleeding from the tailings stored in underground workings: the estimated bleed water flow rate from the tailings stored in the underground workings is 149 m<sup>3</sup>/h (see Chapter 18);
- Water used for underground mining operation is estimated at a flow rate of 60 m<sup>3</sup>/h.

Dewatering flow rates were estimated for three situations:

- Preproduction dewatering: It is during this phase that the dewatering flow rate will be the most significant. Based on the estimates presented above, the average pumping rate for preproduction is estimated to be ranging between 300 m<sup>3</sup>/h and 600 m<sup>3</sup>/h (Table 16-8).

**Table 16-8: Estimated dewatering flow rate – preproduction dewatering**

	<b>Preproduction Dewatering</b>
<b>A:</b> Volume of water stored in underground workings to be pumped during the preproduction dewatering	10.58 Mm <sup>3</sup>
<b>B:</b> Groundwater inflow rate in the mine workings	80 m <sup>3</sup> /h
<b>C:</b> Average preproduction dewatering flow rate	600 m <sup>3</sup> /h

- Production before tailings deposition at the surface (without surface TMF): Most of the water pumped from the underground mine during this period will be groundwater inflow into dewatered workings (estimate of 80 m<sup>3</sup>/h), water bleed from the tailings stored in underground workings (estimate 149 m<sup>3</sup>/h) and water for underground mining operation (estimate 60 m<sup>3</sup>/h) (see Section 20.2.8.6 for an estimate of the bleeding flow rate).
- Production once tailings are disposed of at the surface (with surface TMF): Most of the water pumped from the underground mine during this period will be groundwater inflow into dewatered workings (estimate of 80 m<sup>3</sup>/h) and water used for underground mining operation (estimate 60 m<sup>3</sup>/h). The bleed water from the tailings is considered negligible during this stage of production.

## 16.4 Mine Dewatering

### 16.4.1 Old Workings Interconnections

Before reaching the Horne 5 deposit, the adjacent mine workings must first be dewatered or isolated from the Horne 5 deposit. The Horne 5 Mining Complex is surrounded by the historical Horne, Quemont, Chadbourne, Joliet and Donalda mines, all of which are connected by underground drifts. The connecting points between these mines have been established based on available historical data. No visual inspections were possible as all the mines have been flooded following their closures. Figure 16-5 shows these inter-mine connections.

In the past, water levels in each mine were managed independently. During historical production, connections and barricades were created between the mines to manage water levels. No as-built construction plans for the barricades have been found. The known interconnections are as follows:

- Between historical Horne level 3 (current HL115) and the historical Quemont level 200 (current Q64), equipped with a non-hydrostatic barricade;
- Between historical Horne level 9 (current HL322) and the Joliet mine level 900 (current level L322), equipped with a hydrostatic barricade;
- Between historical Horne level 9 (current HL322) and the Chadbourne mine level 09 (current level L322), no known barricade;
- Between historical Quemont level 1260 (current Q385) and the Donalda mine level 7 (approximate depth of 385 m), equipped with a non-hydrostatic barricade.

To access the Horne 5 deposit, some of the surrounding historical mines need to be dewatered. The overall objective of the dewatering plan is to appropriately and safely manage the activities required to pump water from the Quemont, Donalda and Horne mines while avoiding or mitigating impacts on the surrounding operations and the environment.

- As the connection between the Joliet and Horne mines is equipped with a hydrostatic barricade, the Joliet mine will remain as is, while pumping out water from the Horne mine.
- A remote hydrostatic barricade will be built in the connecting drift between the Horne and Chadbourne mines by injecting concrete in drill holes. This barricade will allow the dewatering of the historical Horne mine without pumping water from the Chadbourne mine.
- The Donalda and Quemont mines will be dewatered to allow sufficient storage for the preproduction water treatment sludge.
- One barricade will be built in the connecting drift between the Quemont and Donalda mines by injecting concrete in drill holes to isolate the production shaft from the historical Donalda mine.

- 
- Barricades will be built around the Quemont No. 2 shaft to isolate the production shaft from the historical Quemont mine. The barricades construction will be simultaneous to the shaft rehabilitation.
  - The connections between the historical Horne mine and the Horne 5 Mining Complex are limited. However, for safety reasons, the historical Horne mine needs to be completely dewatered.

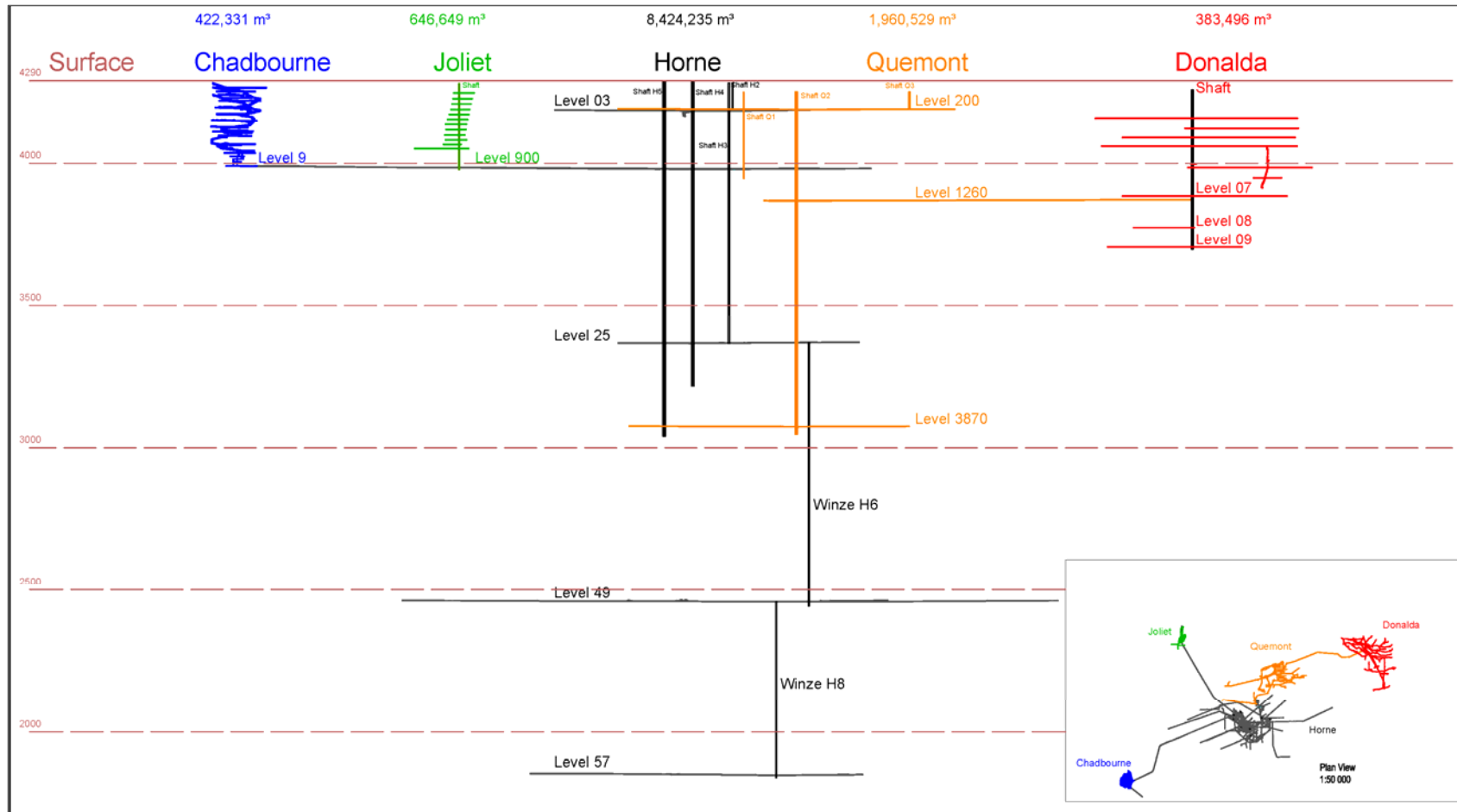

Figure 16-5: Connections between historical mines

## 16.4.2 Void and Water Volume Estimation in Historical Mines

At an early stage of the mining operations, a set of tests will be performed to evaluate the water properties and confirm the recharge rate, which is currently estimated at 80 m<sup>3</sup>/h. This information will improve the accuracy of the time and cost estimates for the dewatering process, and will confirm the pump selection. The dewatering sequence herein uses the estimated 80 m<sup>3</sup>/h recharge rate.

Many assumptions need to be validated to improve confidence in the estimated water quantities of each mine and in the status of the hydrostatic plugs. It is recommended that sensors be installed in each mine to monitor water levels during the dewatering process. This will allow correlations to be made between dewatering rates and estimated volumes of water. Major differences between the two could reflect the presence of an anomaly, such as:

- Failure of an existing hydrostatic plug;
- An unidentified connection;
- Sectors that are not draining; or
- Connections via drill holes.

A risk management program was produced and will be initiated before proceeding with any underground activities.

The volumes of water stored in the existing underground workings have been estimated for each mine based on the available historical production and development data, supplemented by 3D models of the underground workings for the historical Horne, Chadbourne and Quemont mines. The models allowed the volume estimates to include stopes and development excavations in addition to shafts, stations, raises and drifts.

More than 42,000 documents were consulted, digitized and georeferenced to build the 3D models of the five mines. Most of the documents were obtained from the Glencore archives in Rouyn-Noranda, whereas others were from the MERN archives.

### 16.4.2.1 Quemont Mine

The historical production for the Quemont mine was 13,924,000 t, for an extracted volume of 3,933,434 m<sup>3</sup>, processed at the Quemont mill (with a density of 3.54 t/m<sup>3</sup>). All digitized Quemont mine documents were obtained from the Glencore Horne smelter vault and the MERN archives. The 3D model is shown in Figure 16-6. The volumes were calculated in GEMS using this model. The Quemont mine model is incomplete as some documents could not be found.

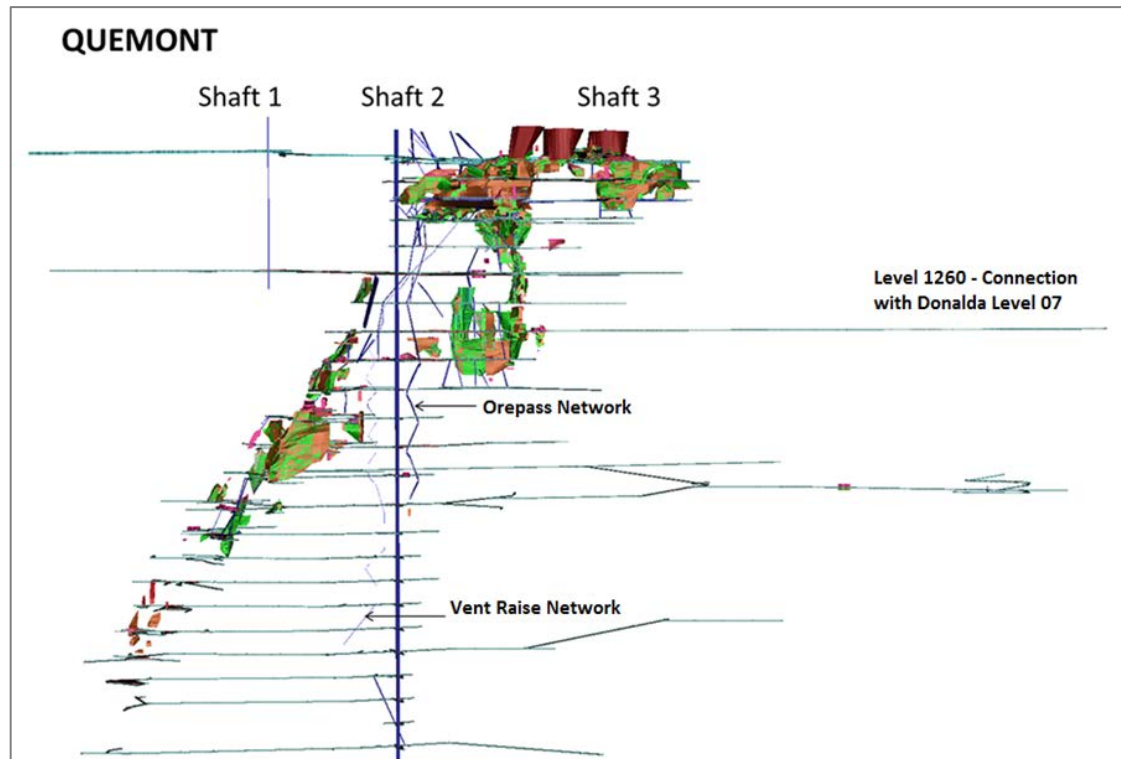

Figure 16-6: Quemont mine 3D model

### Void Volume Calculations

Volumes were separated into two types: excavations and stopes.

- Digitized excavations:
  - Total volume of excavations: 415,524 m<sup>3</sup>;
  - Total volume of Quemont No. 2 shaft and station: 89,695 m<sup>3</sup>;
  - Total volume of raises: 22,083 m<sup>3</sup>;
  - Total volume of drifts: 303,746 m<sup>3</sup>.
- Digitized stopes:
  - Total volume of all stopes: 2,364,833 m<sup>3</sup>;
  - Total volume of backfilled stopes: 2,175,720 m<sup>3</sup>;
  - Total volume of unfilled stopes: 2,364,833 m<sup>3</sup> - 2,175,720 m<sup>3</sup> = 189,114 m<sup>3</sup>;
  - Percentage of unfilled stopes: 189,114 m<sup>3</sup> / 2,175,720 m<sup>3</sup> = 8%.

- Missing information from the historical production data:
  - Volume sent to the process plant: 3,933,434 m<sup>3</sup>;
  - Missing volume based on the digitized model: 3,933,434 m<sup>3</sup> - 2,364,833 m<sup>3</sup> = 1,568,601 m<sup>3</sup>;
  - Total volume of missing unfilled stopes (8%): 1,568,601 m<sup>3</sup> x 8% = 125,488 m<sup>3</sup>;
  - Total volume of missing backfilled stopes (100%-8% = 92%): 1,568,601 m<sup>3</sup> x 92% = 1,443,113 m<sup>3</sup>.

From these calculations, the total volume of unfilled excavations and stopes available in the historical Quemont mine is the sum of:

- $415,524 \text{ m}^3 + 189,114 \text{ m}^3 + 125,488 \text{ m}^3 = 730,126 \text{ m}^3$ .

#### Water Volume Calculations

Based on the void volume calculation, it was possible to estimate the volume of water to pump out of the historical Quemont mine using the following assumptions:

- 100% flooded;
- Percentage of water-filled voids in backfill: 34% (backfill was rockfill, based on historical documents).

The volume of water is calculated as follows:

- 100% of excavations: 415,524 m<sup>3</sup>;
- 100% of unfilled stopes: 314,602 m<sup>3</sup>:
  - Voids in digitized stopes: 189,114 m<sup>3</sup>;
  - Voids in missing stopes: 125,488 m<sup>3</sup>.
- 34% of backfilled stopes: 1,230,403 m<sup>3</sup>:
  - Voids from digitized backfilled stopes: 2,175,720 m<sup>3</sup> x 34% = 739,745 m<sup>3</sup>;
  - Voids from missing backfilled stopes: 1,443,113 m<sup>3</sup> x 34% = 490,658 m<sup>3</sup>.

From these calculations, the total volume of water in the historical Quemont mine is the sum of:

- $415,524 \text{ m}^3 + 314,602 \text{ m}^3 + 1,230,403 \text{ m}^3 = 1,963,343 \text{ m}^3$ .

#### 16.4.2.2 Chadbourne Mine

The historical production for the Chadbourne mine was 1,640,000 t, for an extracted volume of 585,714 m<sup>3</sup>, processed at the process plant (with a density of 2.8 t/m<sup>3</sup>). All digitized Chadbourne mine documents were obtained from the Glencore Horne smelter vault. The 3D model is shown in Figure 16-7. The volumes were calculated in GEMS using this digitalized model.

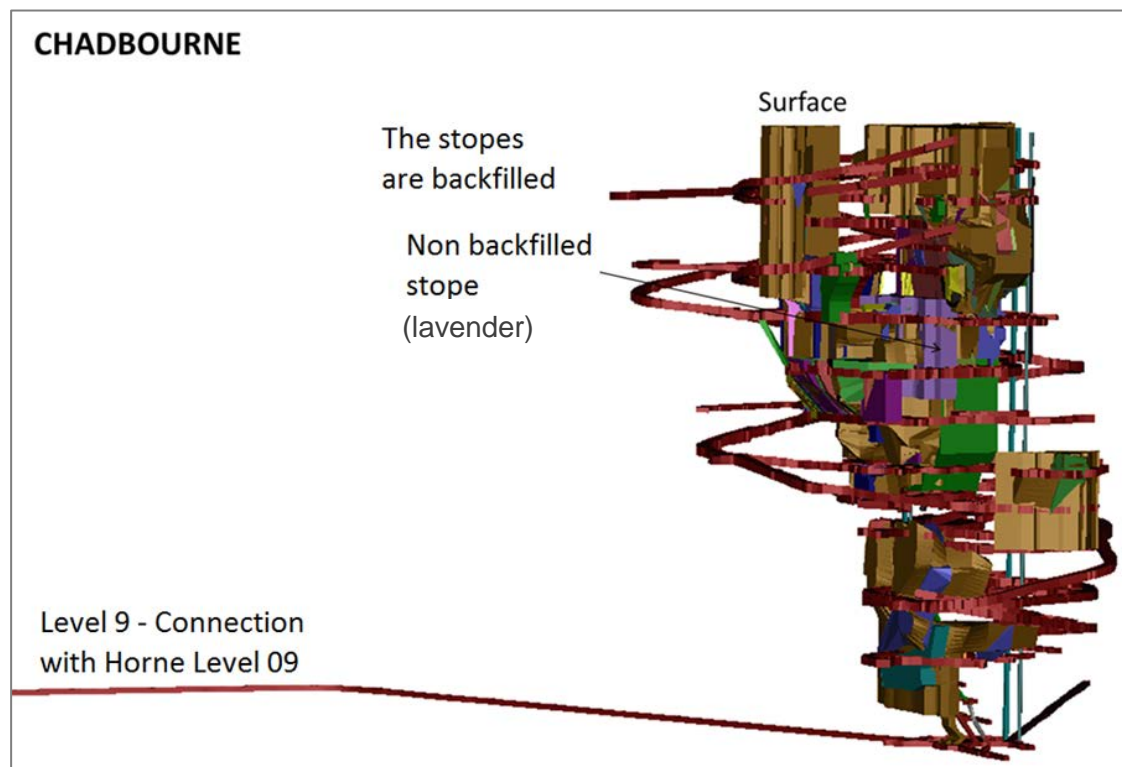

Figure 16-7: Chadbourne mine 3D model

#### Void Volume Calculations

Volumes were separated into two types: excavations and stopes.

- Digitized excavations:
  - Total volume of excavations: 212,149 m<sup>3</sup>;
  - Total volume of raise: 4,195 m<sup>3</sup>;
  - Total volume of drifts: 207,954 m<sup>3</sup>.



- Digitized stopes:
  - Total volume of all stopes: 665,862 m<sup>3</sup>;
  - Total volume of backfilled stopes: 651,215 m<sup>3</sup>;
  - Total volume of unfilled stopes: 665,862 m<sup>3</sup> - 651,215 m<sup>3</sup> = 14,647 m<sup>3</sup>;
  - Percentage of unfilled stopes: 14,647 m<sup>3</sup> / 665,862 m<sup>3</sup> = 2%.

The historical data reports a volume of 585,714 m<sup>3</sup> sent to the process plant. However, the calculated volume from the digitalisation is 665,862 m<sup>3</sup>, 80,148 m<sup>3</sup> more than the historical data. It is considered that the volume from the digitalization represents the real volume (100%).

From these calculations, the total volume of unfilled excavations and stopes in the historical Chadbourne mine is the sum of:

- 212,149 m<sup>3</sup> + 14,647 m<sup>3</sup> = 226,796 m<sup>3</sup>.

#### Water Volume Calculations

Based on the voids volume calculation, it was possible to estimate the water to pump out of the historical Chadbourne mine using the following assumptions:

- Actual water level in the mine is under level N01 as per measurements by Golder: 51,371 m<sup>3</sup>;
- Actual percent of water into the backfill: assumption is 34% water into the rockfill.

Water volume calculation is based on the following data:

- 100% of voids from the digitalized excavations: 212,149 m<sup>3</sup>;
- 100% of voids from the digitalized stopes: 14,647 m<sup>3</sup>;
- 34% of backfill in the stopes: 246,636 m<sup>3</sup>:
  - Backfill in digitalized stopes: 725,400 m<sup>3</sup> x 34% = 246,636 m<sup>3</sup>.

From these calculations, the total volume of water in the historical Chadbourne mine is the sum of:

- 212,149 m<sup>3</sup> + 14,647 m<sup>3</sup> + 246,636 m<sup>3</sup> – 51,375 m<sup>3</sup> = 422,061 m<sup>3</sup>.

### 16.4.2.3 Joliet Mine

The historical production for the Joliet mine was 2,080,000 t, for an extracted volume of 693,333 m<sup>3</sup> (with a density of 3.0 t/m<sup>3</sup>). Joliet mine documents were available for digitalization from the Glencore Horne smelter vault. From the digitalization of the available documents, a 3D model was produced (Figure 16-8), out of which GEMS was used to calculate the volumes.

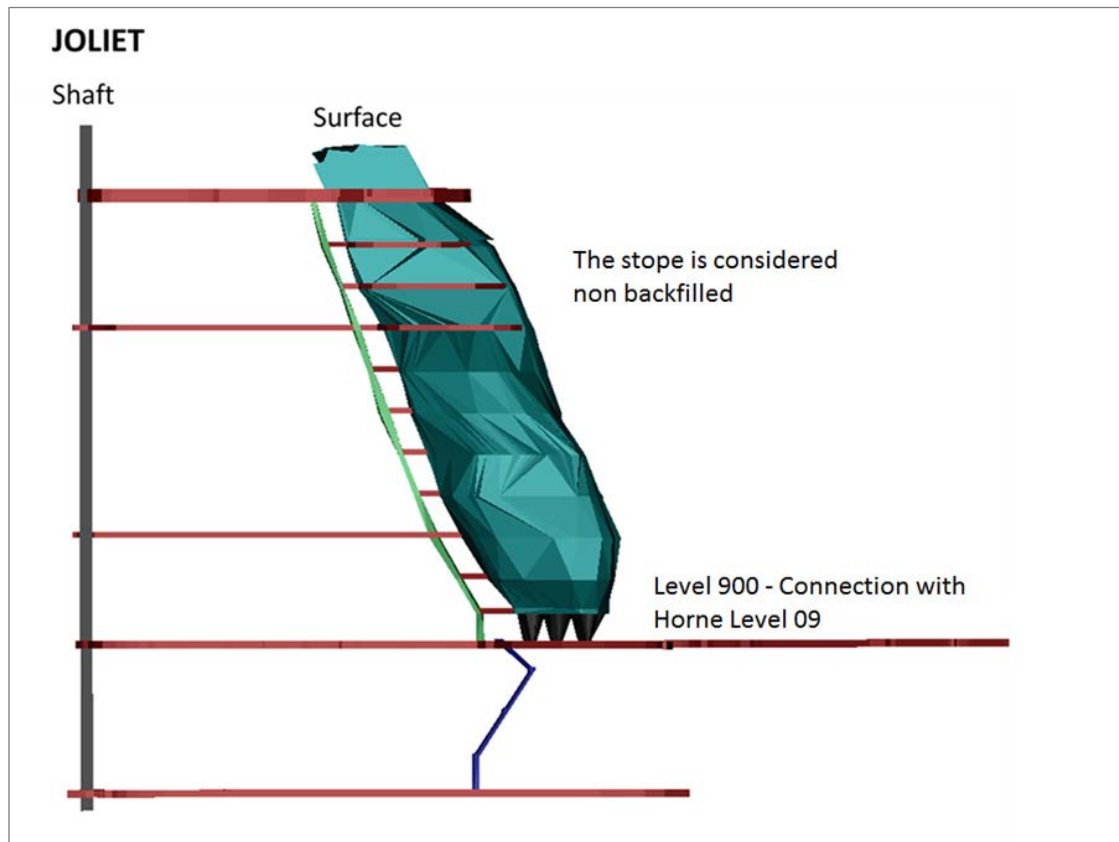

Figure 16-8: Joliet mine 3D model

#### Void Volume Calculations

Volumes were separated into two types: excavations and stopes.

- Digitized excavations:
  - Total volume of excavations: 39,080 m<sup>3</sup>;
  - Total volume of raise: 10,085 m<sup>3</sup>;
  - Total volume of drifts: 28,995 m<sup>3</sup>;

- Digitized stopes:
  - Total volume of all stopes: 607,569 m<sup>3</sup>;
  - There is no information about any backfill use in the historical Joliet mine. It is considered that volumes are all voids.

The historical data reports a volume of 693,333 m<sup>3</sup> sent to the process plant. However, the calculated volume from the digitalisation is 607,569 m<sup>3</sup>, 85,764 m<sup>3</sup> less than the historical data. It is considered that the volume from the digitalization represents the real volume (100%).

From these calculations, the total volume of unfilled excavations and stopes in the historical Joliet mine is the sum of:

- 39,080 m<sup>3</sup> + 607,569 m<sup>3</sup> = 646,649 m<sup>3</sup>.

#### Water Volume Calculations

Based on the voids volume calculations, it was possible to estimate the water to be pumped out of the historical Joliet mine using the following assumptions:

- Actual water level in the mine needs to be confirmed. Assumption is 100% flooded.

Water volume calculation is based on the following data:

- 100% of voids from the digitalized excavations: 39,080 m<sup>3</sup>;
- 100% of voids from the digitalized stopes: 607,569 m<sup>3</sup>.

From this calculation, the total volume of water in the historical Joliet mine is the sum of:

- 39,080 m<sup>3</sup> + 607,569 m<sup>3</sup> = 646,649 m<sup>3</sup>.

#### 16.4.2.4 Donalda Mine

The historical production for the Donalda mine was 738,900 t, for an extracted volume of 263,893 m<sup>3</sup> (with a density of 2.8 t/m<sup>3</sup>). Donalda mine documents were available for digitalization from the MERN archives. From the digitalization of the available documents, a 3D model was produced (Figure 16-9), out of which GEMS was used to calculate the volumes.

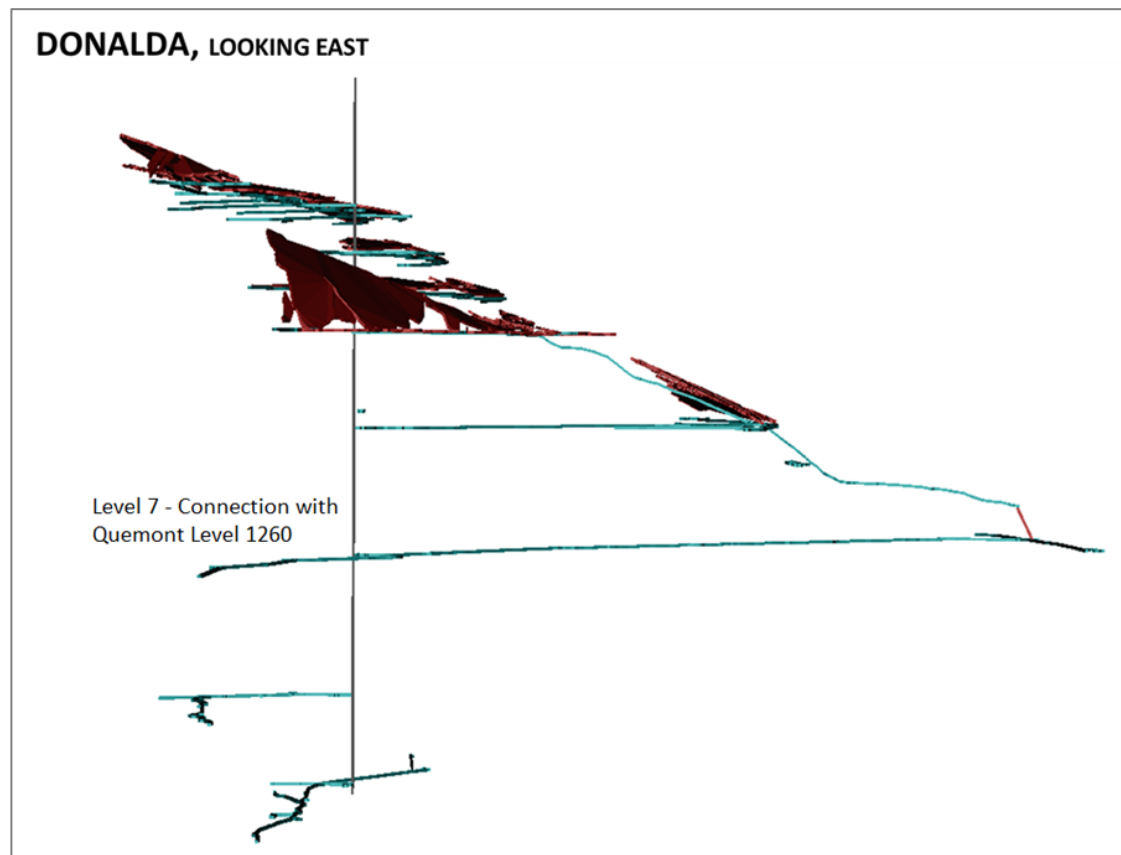

Figure 16-9: Donalda mine 3D model

#### Void Volume Calculations

Volumes were separated into two types: excavations and stopes.

- Digitized excavations:
  - Total volume of excavations: 60,631 m<sup>3</sup>;
    - Total volume of raise: 6,814 m<sup>3</sup>;
    - Total volume of drifts: 53,817 m<sup>3</sup>.

- Digitized stopes:
  - Total volume of all stopes: 341,065 m<sup>3</sup>;
  - There is no information about any backfill use in the historical Donalda mine. It is then considered that volumes are all voids.

The historical data reports a volume of 263,893 m<sup>3</sup> sent to the process plant. However, the calculated volume from the digitalisation is 341,065 m<sup>3</sup>, 77,172 m<sup>3</sup> more than the historical data. It is considered that the volume from the digitalization represents the real volume (100%).

From these calculations, the total volume of unfilled excavations and stopes in the historical Donalda mine is the sum of:

- $60,631 \text{ m}^3 + 341,065 \text{ m}^3 = 401,696 \text{ m}^3$ .

#### Water Volume Calculations

Based on the voids volume calculations, it was possible to estimate the water to be pumped out of the historical Donalda mine using the following assumptions:

- Actual water level in the mine needs to be confirmed. Assumption is 100% flooded.

Water volume calculation is based on the following data:

- 100% of voids from the digitalized excavations: 60,631 m<sup>3</sup>;
- 100% of voids from the digitalized stopes: 341,065 m<sup>3</sup>;
- There is a captive water volume under the Quemont and Donalda connection: 18,200 m<sup>3</sup>.

From these calculations, the total volume of water in the historical Donalda mine is the sum of:

- $60,631 \text{ m}^3 + 341,065 \text{ m}^3 - 18,200 \text{ m}^3 = 383,496 \text{ m}^3$ .

#### 16.4.2.5 Horne Mine

The historical production for the Horne mine was 59,050,000 t, for an extracted volume of 15,539,000 m<sup>3</sup>, processed to the Horne process plant and smelter (with a density of 3.8 t/m<sup>3</sup>). Horne mine documents were available for digitalization from the Glencore Horne smelter archives. From the digitalization of the available documents, a 3D model was produced (Figure 16-10), out of which GEMS was used to calculate the volumes.

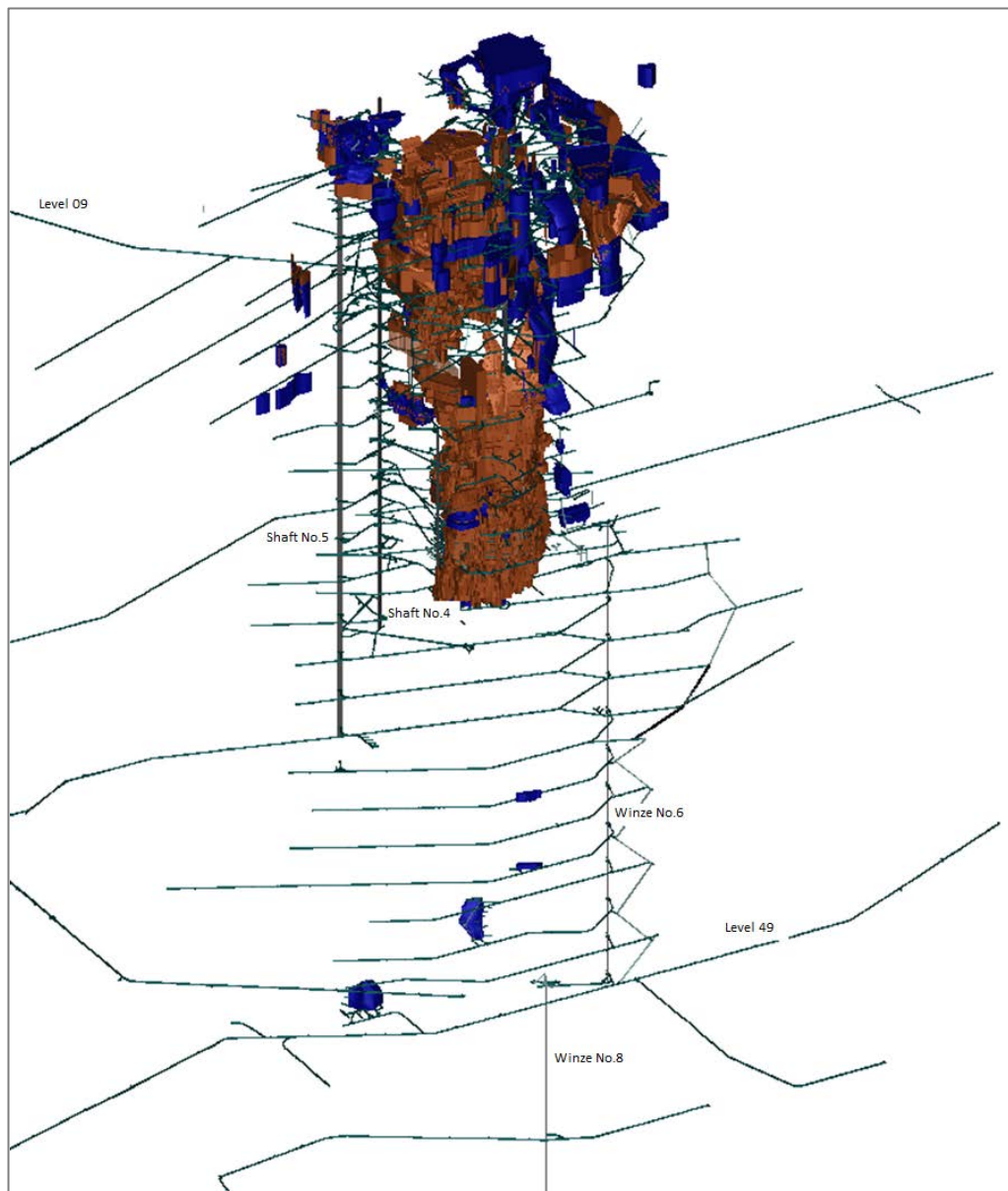

Figure 16-10: Horne mine 3D model

### Void Volume Calculations

Volumes were separated into two types: excavations and stopes.

- Digitized excavations:
  - Total volume of excavations: 616,289 m<sup>3</sup>:
    - Total volume of Horne No. 4 shaft and station: 41,463 m<sup>3</sup>;
    - Total volume of other Horne shafts and winze: 61,459 m<sup>3</sup>;
    - Total volume of raise: 21,491 m<sup>3</sup>;
    - Total volume of drifts: 491,876 m<sup>3</sup>.
- Digitized stopes:
  - Total volume of all stopes: 17,331,775 m<sup>3</sup>;
  - Total volume of backfilled stopes: 13,151,451 m<sup>3</sup>;
  - Total volume of unfilled stopes: 17,331,775 m<sup>3</sup> - 13,151,451 m<sup>3</sup> = 4,180,324 m<sup>3</sup>;
  - Percentage of unfilled stopes: 4,180,324 m<sup>3</sup> / 17,331,775 m<sup>3</sup> = 24 %.

The historical data reports a volume of 15,539,000 m<sup>3</sup> sent to the process plant. However, the calculated volume from the digitalisation is 17,331,775 m<sup>3</sup>, 1,792,775 m<sup>3</sup> more than the historical data. It is considered that the volume from the digitalization represents the real volume (100%).

From these calculations, the total volume of unfilled excavations and stopes in the historical Horne mine is the sum of:

- $616,289 \text{ m}^3 + 4,180,324 \text{ m}^3 = 4,796,613 \text{ m}^3$ .

### Water Volume Calculations

Based on the voids volume calculations, it was possible to estimate the water to be pumped out of the historical Horne mine under certain assumptions:

- Actual water level in the Horne No. 5 shaft is 50 m under the collar. Measured by Golder. Assumption is that the first level is not flooded, 843,781 m<sup>3</sup>;
- Actual percent of water into the backfill: assumption is 34% of water into the rockfill.

Water volume calculation is based on the following data:

- 100% of voids from the digitalized excavations: 616,289 m<sup>3</sup>;
- 100% of voids from the digitalized stopes: 4,180,324 m<sup>3</sup>;
- 34% of backfill in the stopes: 4,471,493 m<sup>3</sup>:
  - Backfill in digitalized stopes: 13,151,451 m<sup>3</sup> x 34% = 4,471,493 m<sup>3</sup>.

From these calculations, the total volume of water in the historical Horne mine is the sum of:

- $616,289 \text{ m}^3 + 4,180,324 \text{ m}^3 + 4,471,493 \text{ m}^3 - 843,781 \text{ m}^3 = 8,424,326 \text{ m}^3$ .

#### 16.4.2.6 Volume Summary

Table 16-9 and Table 16-10 present the summary of voids and water volume estimates based on historical production data and digitalization of archive plans.

Table 16-9: Estimated voids volumes for the Horne 5 Project

Historical Mines	Voids volume in excavations (m <sup>3</sup> )	Voids volume in open stopes (m <sup>3</sup> )	Estimated voids volume (Mm <sup>3</sup> )
Quemont	415,524	314,601	<b>0.73</b>
Chadbourne	212,149	14,647	<b>0.23</b>
Joliet	39,080	607,569	<b>0.65</b>
Donalda	60,631	341,065	<b>0.40</b>
Horne	616,289	4,180,324	<b>4.80</b>
<b>Total</b>	<b>1,343,673</b>	<b>5,458,206</b>	<b>6.80</b>

Table 16-10: Estimated water volumes for the Horne 5 Project dewatering

Historical Mines	Water volume in excavations (m <sup>3</sup> )	Water volume in open stopes (m <sup>3</sup> )	Backfilled stopes volume (m <sup>3</sup> )	Water volume in backfilled stopes (m <sup>3</sup> )	Water volume correction (m <sup>3</sup> )	Estimated volume of water (Mm <sup>3</sup> )
Quemont	415,524	314,602	3,618,833	1,230,403	0	<b>1.96</b>
Chadbourne	212,149	14,647	665,862	246,636	51,371	<b>0.42</b>
Joliet	39,080	607,569	0	0	0	<b>0.65</b>
Donalda	60,631	341,065	0	0	18,200	<b>0.38</b>
Horne	616,289	4,180,324	13,151,451	4,471,493	843,781	<b>8.42</b>
<b>Total</b>	<b>1,343,673</b>	<b>5,458,207</b>	<b>17,436,146</b>	<b>5,948,533</b>	<b>913,352</b>	<b>11.84</b>



### 16.4.3 Dewatering Installations and Infrastructure

Dewatering from the surface will be first done from the Horne 5 shaft, Quemont No. 2 shaft and Donalda shaft. In each case, a surface set-up will manage the submersible pumps. The pumps will be dropped down in the shaft to a depth between 100 m and 375 m from the collar. The combined water pumping rate will be at a maximum of 600 m<sup>3</sup>/h directly sent to the surface. From the surface, water will be sent to a water treatment unit. Several submersible, high-volume and high-pressure stainless steel pumps will be required to remove water from the historical mines. These pumps can be remotely lowered down the shafts without any installation in the shaft. Figure 16-11 shows the final temporary network for the dewatering.

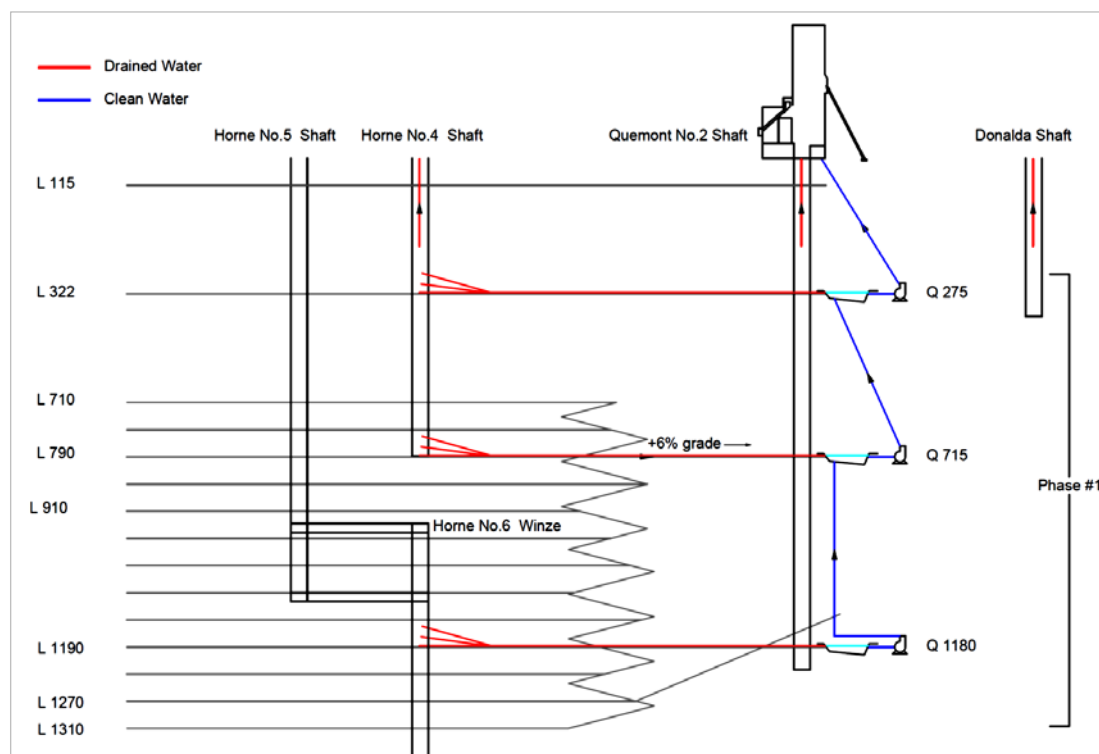
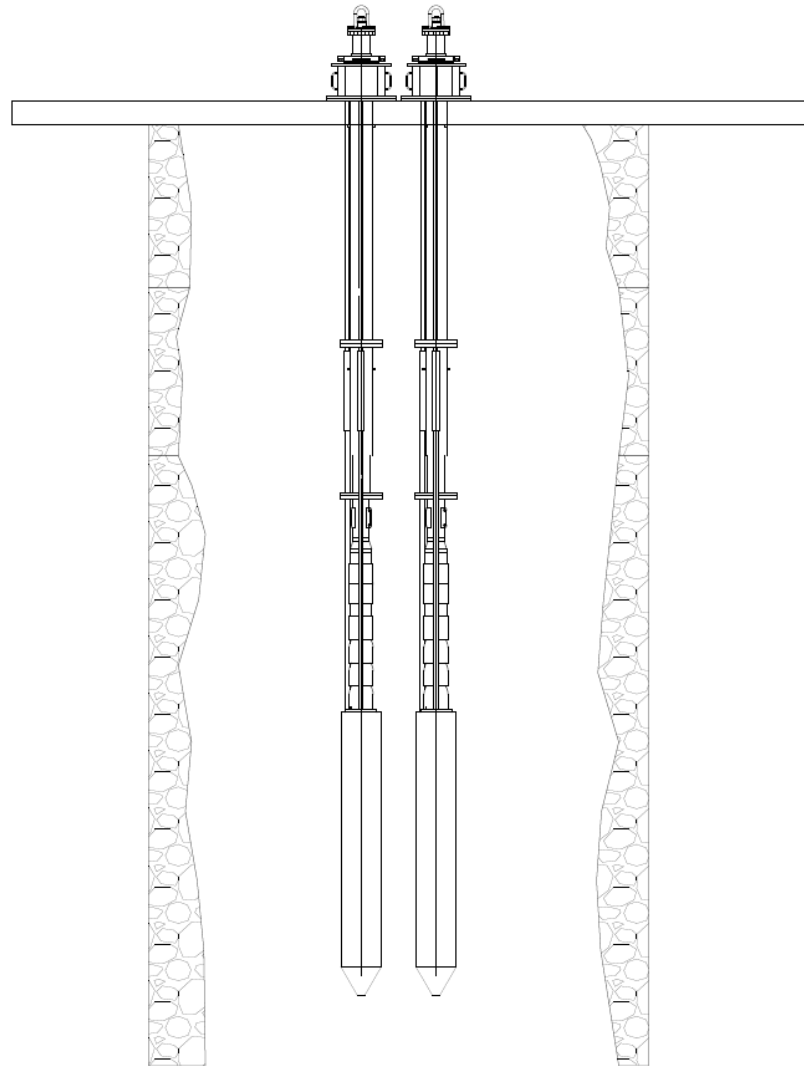

Figure 16-11: Temporary dewatering network – main steps (1 to 3)

Figure 16-12 represents the general arrangement for the surface pumping station.

- The Horne 5 shaft installation consists of two 400 hp submersible pumps that will be installed from the surface to a maximum of 230 m deep with rigid piping set-up;
- Quemont No. 2 shaft installation consists of one 400 hp submersible pump to a depth of 275 m;
- Donalda shaft installation consists of one 250 hp submersible pump to a depth of 375 m.



**Figure 16-12: Surface pumping station general arrangement**

Once the Quemont No. 2 shaft has been dewatered down to level Q275 by the surface installation, new submersible pumps will be installed underneath the Galloway to follow the shaft rehabilitation. Two 150 hp stainless steel pumps will feed a 500 hp multistage pump installed directly on the Galloway deck to direct the water at the surface or at the main pumping stations. Figure 16-13 shows a typical booster pump installed on a Galloway.



Figure 16-13: Typical booster pump installed on a Galloway

After completion of the Quemont No. 2 shaft dewatering, drainage holes will be used to dewater the historical Horne mine. Figure 16-14 shows the drainage system installation. Drilling bays will be used to drain water from the historical Horne mine to the Quemont main pumping station. This system will securely drain high-pressure water by drilling 3 inch diameter holes of 150 m to 350 m to reach the historical Horne mine openings. The water from those drain holes will be directed to a sump and then pumped out to the main pumping stations by submersible pumps.

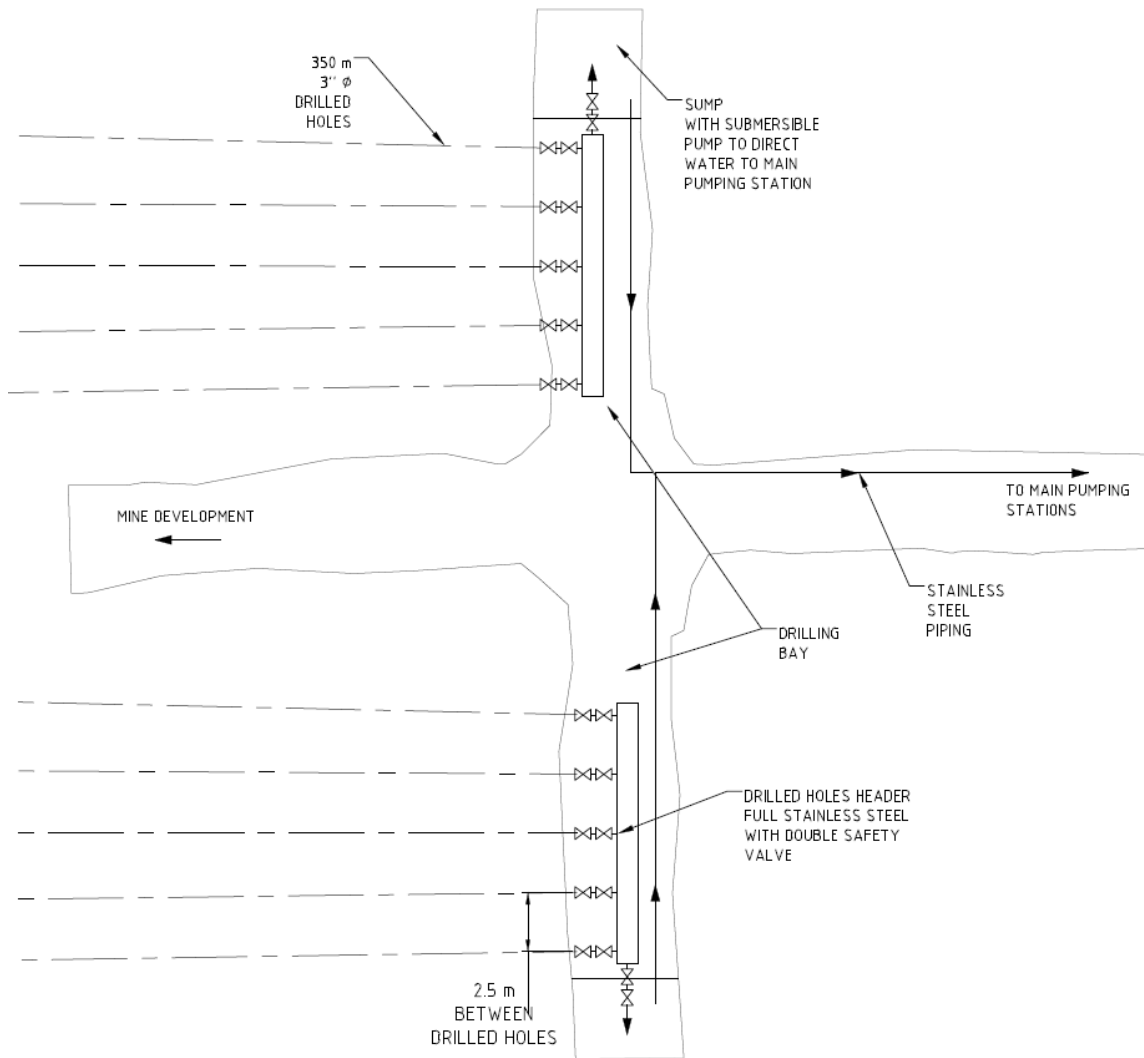

Figure 16-14: Drainage system installation

All permanent installations for dewatering will be set up on the Quemont side of the Horne 5 Mining Complex. As soon as the levels Q275 (connecting with L322), Q715 (connecting with L790) and Q1180 (connecting with L1190) are reached, the main clear water pumping stations will be built in priority to support and contribute to dewatering of the Quemont and Horne mines. As the Galloway will go further down and the Quemont No. 2 shaft will be rehabilitated, the main pumping station will be used as a booster to bring the water to the surface.

## 16.4.4 Pre-dewatering

### 16.4.4.1 Crown Pillar Stability

A crown pillar stability assessment of the near surface (within 100 m from the surface), based on the empirical scaled span method and crown pillar risk exposure guidelines, was completed for the historical underground workings of the mines with confirmed or potential hydraulic connections with the Horne and Quemont mines.

The study was completed in planning for the preproduction dewatering phase of the Project, but the crown pillar stability was estimated in both current (dry or flooded/static) and dewatering conditions. The location and geometry of all the considered openings, i.e., presenting an opening to the surface or a crown pillar within 100 m from the surface, have been extracted from the 3D model built by InnovExplo from historical plans and sections for the Horne, Quemont, Chadbourne, Donalda and Joliet mines.

The interpretation of the results demonstrates low to high probability of failure in current conditions and generally increases under the dewatering conditions. Based on the results, 36 crown pillars were identified as critical (classes A through C) in current (dry or flooded/static) conditions and 41 under dewatering conditions. Overall, 45 crown pillars (classes A through E) across the four properties would require investigation, monitoring, access restriction and/or rehabilitation.

The responsibility to ensure stability of near surface crown pillars remains with the Third Party owner of the mining infrastructure.

### 16.4.4.2 Underground Rehabilitation of Quemont No. 2 Shaft

One of the key components and the first step to prepare for the dewatering project was gaining access to Quemont No. 2 shaft. Falco has initiated this step by opening the shaft collar. Further inspection must be completed to secure the work.

Dewatering of the Quemont No. 2 shaft will allow for the shaft rehabilitation, the AMQ has produced a document explaining in detail the different steps to follow for dewatering old underground mines, which Falco intends to respect and review with the selected specialized contractor. Falco will submit its dewatering plan to the Third Party for approval, as well as all supporting technical documentation in connection with obtaining licenses to access, modify and use the Quemont No. 2 shaft for the Project.

All necessary regulatory authorizations will be obtained from the authorities by Falco prior to beginning the dewatering operations. In March 2016, Falco obtained a CoA from the MDDELCC for a partial dewatering of Quemont No. 2 shaft (up to 100 m) (MDDELCC, 2016).

In July 2017, Falco requested a CoA from the MDDELCC for the preproduction dewatering and rehabilitation program.

#### 16.4.4.3 Water Volume

The volume of water stored in the underground workings at the Quemont, Horne, Chadbourne, Donalda and Joliet mines is estimated at 11.8 Mm<sup>3</sup> (see Section 16.4.2.6). This estimate was used to evaluate the volume of water to be pumped for the dewatering of Quemont, Horne and Donalda mines to different depths. Figure 16-15 presents the estimated volume of water for each mine, the connections through drifts and the known historical hydrostatic plugs. As shown in Figure 16-15, plugs are present in drifts between:

- Quemont and Horne mines (Q64 connecting with level HL115 at 115 m), non-hydrostatic;
- Joliet and Horne mines (Q275 connecting with level HL322 at 322 m), hydrostatic;
- Quemont and Donalda mines (Q385), non-hydrostatic.

The actual efficiency of these plugs is not well documented. Information, provided by Falco from historical water-level measurements at the REMNOR and Quemont shafts, suggests that the Horne and Quemont mines could be hydraulically connected.

The Chadbourne and Joliet mines won't need to be dewatered. The plan is to keep both mines hydraulically disconnected from the Horne 5 mine. The existing hydrostatic plug between the Joliet and Horne mines, with the addition of a new hydrostatic plugs, will insure the Horne 5 mine remains hydraulically isolated from the other mines.

The dewatering process represents about 10.8 Mm<sup>3</sup> of water at a rate of 600 m<sup>3</sup>/h.

Prior to any pumping activities:

- A remote hydrostatic plug will be put in place from the surface to isolate the Chadbourne mine from the Horne mine;
- Since the plug in place between the Horne and Quemont mines is non-hydrostatic, a new plug will be put into place from the surface to isolate the historical Horne mine from pumping activities at the Quemont and Donalda mines;
- The connection between Horne and Joliet will also be secured by adding a remote hydrostatic barricade from surface.



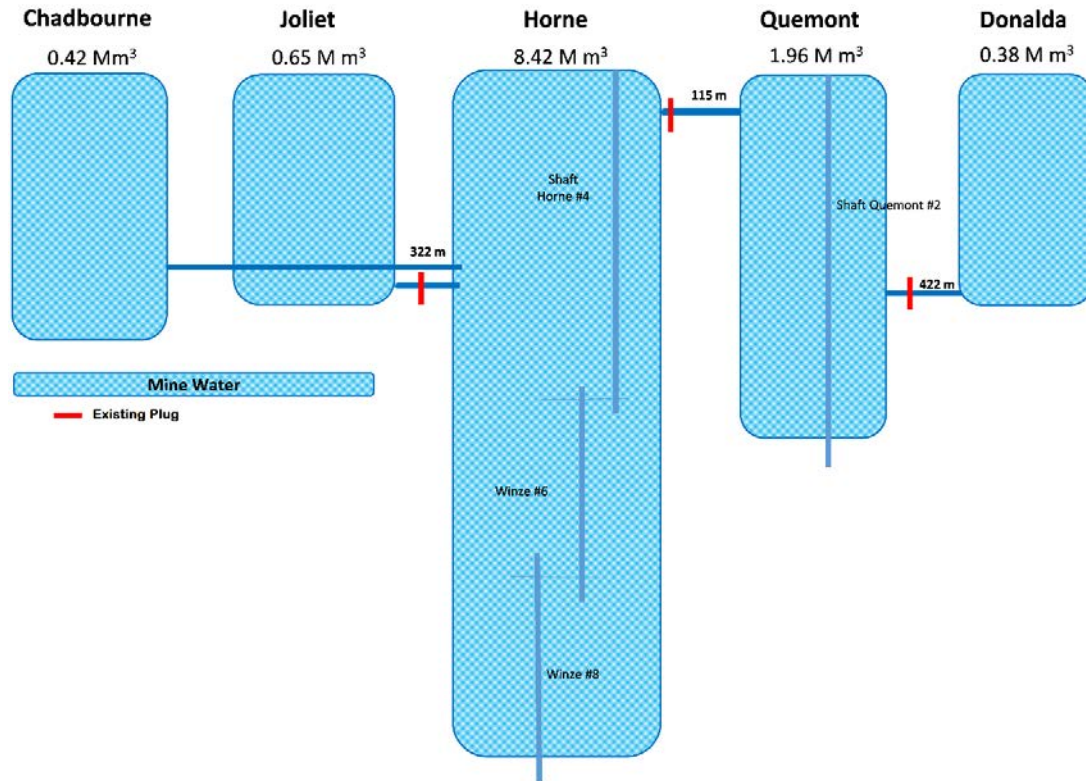

Figure 16-15: Estimated volume of water stored in underground workings

The duration and pumping rates of the different stages are based on the estimated volume of water stored underground. Groundwater inflow has been added to this estimate to evaluate the total volume of water to be managed during the dewatering phase. Pumping will be performed 24 h/day, seven days per week with an equipment availability of 90%. The flow rate of water that could be supplied to a third party industrial operation is estimated at 80 m<sup>3</sup>/h and corresponds to the estimated groundwater recharge during and after dewatering.

#### 16.4.5 Dewatering Steps

The dewatering rate will be adapted to the rehabilitation and development activities during the preproduction period and flows can either come from four pumping sources:

- Surface installation on top of Horne 5 shaft;
- Surface installation on top of Quemont No. 2 shaft or from the Galloway while rehabilitating Quemont No. 2 shaft;
- Surface installation on top of Donalda shaft;
- Main permanent clear water pumping station during Horne mine drainage steps.

To allow dewatering activities in the Quemont No. 2 shaft, a rehabilitation Galloway will be used. When far-off the surface, a booster pump on the Galloway will be connected to a main permanent clear water pumping installation located on already rehabilitated stations of the Quemont mine.

The historical Horne mine will be dewatered first by using a pumping installation on top of the Horne 5 shaft and then by using a drainage system connected to the main pumping stations installed near the Quemont No. 2 shaft. The dewatering activities will be carried out in four main steps presented in the following sections. Once the dewatering is completed, the Quemont and Horne mines will remain dry during the Horne 5 LOM.

The first step of the dewatering plan combines dewatering from the collar of the Quemont No. 2 shaft and dewatering from the collar of Donalda shaft, at a pumping rate between 300 m<sup>3</sup>/h and 600 m<sup>3</sup>/h for an estimated duration of 131 days or about 5 months:

- Step 1a: Dewatering from collar of Quemont No. 2 shaft:
  - Down to Q275 station;
  - This is the maximum depth for the pumping configuration of the submersibles pumps used with a boreline (flexible drop piping system);
  - Total of 131 days to pump water down to Q275.
- Step 1b: Dewatering from collar of Donalda shaft:
  - Down to 375 m (maximum of 400 m);
  - At a rate of 150 m<sup>3</sup>/h to ensure sufficient voids are created to allow start of sludge deposit coming from the water treatment of Quemont and Horne dewatering;
  - Independent water treatment plant on surface to send water directly to the effluent;
  - Total of 123 days to pump water out of Donalda.

The second step combines the dewatering of the Quemont No. 2 shaft while being rehabilitated and the dewatering from surface to the first levels of the historical Horne mine. The combined pumping rate for these two simultaneous activities will be 600 m<sup>3</sup>/h and the duration of this step is expected to be about 10.5 months.

- Step 2a: Dewatering to enable the rehabilitation of the Quemont No. 2 shaft to the bottom
  - From level Q275 to the bottom of the Quemont No. 2 shaft;
  - At a rate to ensure full rehabilitation without restricting the productivity of the rehabilitation process.
  - Total of 143 days to pump water out of Quemont No. 2 shaft from level Q275 to level Q715 and a total of 130 days to pump water out from level Q715 to level Q1240;



- Step 2b: Dewatering from the collar of the Horne No. 5 shaft:
  - From 0 m to 230 m from the collar;
  - At a rate of up to 600 m<sup>3</sup>/h;
  - Total of 364 days to pump out water from the collar of the Horne No. 5 shaft to 230 m deep.

The third step is the dewatering of the deep historical Horne mine (>230 m depth) by remote drainage at levels L322, L790 and L1190 via underground inclined boreholes at a pumping rate of 600 m<sup>3</sup>/h for an estimated duration of 10 months:

- Step 3a: Dewatering by remote drainage at L322:
  - Pumping water level from 230 m deep (level HL284) to level L322 of historical Horne, via diamond drill holes from L322 level access;
  - Pumping drained water to the surface from the main permanent clear water pumping station located at Q275 (Quemont No. 2 shaft);
  - Total of 77 pumping days.
- Step 3b: Dewatering by remote drainage at L790:
  - Pumping water level from level L322 to level L790 of Horne, via diamond drill holes from L790 level access;
  - Pumping drained water to the surface from the main permanent clear water pumping station located at Q715 (Quemont No. 2 shaft);
  - Total of 177 pumping days.
- Step 3c: Dewatering by remote drainage at L1190:
  - Pumping water level from level L790 to level L1190, DDH from L1190 access;
  - Pumping drained water to the surface from the main permanent clear water pumping station located at Q1180 (Quemont No. 2 shaft);
  - Total of 73 pumping days.

Steps 3a to 3c need to be managed to maximize the pumping rate of 600 m<sup>3</sup>/h of the whole pumping system and thus minimizing the dewatering period.

The fourth step is the dewatering from the historical Horne mine below L1190 following the mine development progression.

- Step 4a: Dewatering by remote drainage from L1190 to L1310 to the bottom of production Phase 1;
- Step 4b: Dewatering by remote drainage from L1310 to L1850 the bottom of production Phase 2.

The following sections of the Report present the details of each dewatering step.

#### 16.4.5.1 Step 1 (1a and 1b)

Dewatering step 1a is to pump out water from the collar of Quemont No. 2 shaft to station Q275. This will enable the rehabilitation of the first portion of the of Quemont No. 2 shaft without having a pumping installation on the Galloway. The objective is to lower the water table in the Quemont mine up to about 300 m of depth.

At the same time, water from the Donalda shaft will be pumped by a surface installation at the Donalda shaft collar (step 1b). This will equilibrate water levels from the Donalda and Quemont sides, and allowing the water levels to lower from each mine at the same rate, and ultimately to empty the Donalda mine.

The pumping will be carried out using submersible pumps lowered at the Donalda and Quemont No. 2 shafts from the surface, as presented in Section 16.4.3. At this stage, the combined pumping flow rate will vary between 300 m<sup>3</sup>/h and 600 m<sup>3</sup>/h. The duration of this dewatering step is estimated to last 5 months.

The volume of water pumped during this step is estimated at 1.4 Mm<sup>3</sup> for the Quemont mine and 0.38 Mm<sup>3</sup> for the Donalda mine (excluding recharge). The pumped water will be treated through a HDS plant and the water treatment sludge will be disposed and stored in the Donalda mine underground workings using newly drilled boreholes. The estimated volume of water treatment sludge generated during this step is about 65,400 m<sup>3</sup> (at 35% solids). The details of the dewatering and sludge disposal activities for this step are presented in Figure 16-16.

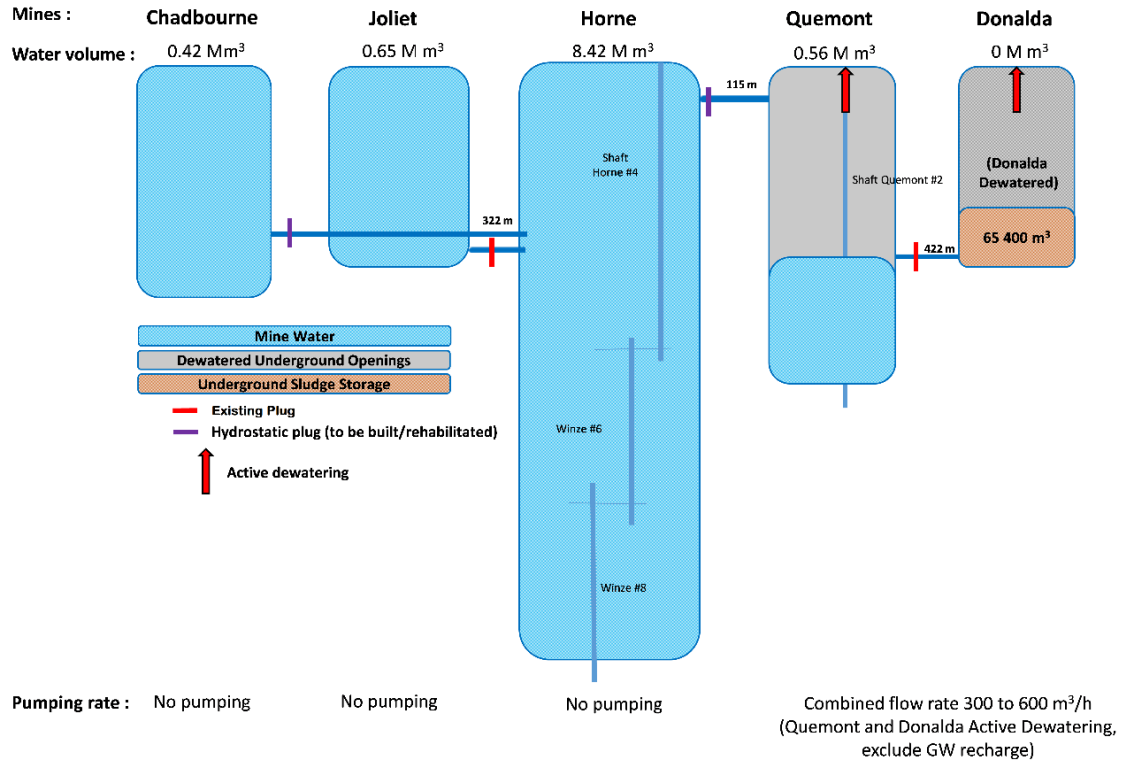

Figure 16-16: Final conditions of dewatering – step 1

#### 16.4.5.2 Step 2 (2a and 2b)

The second dewatering step consists of complete the dewatering of the Quemont mine to the bottom of the Quemont No. 2 shaft and simultaneously pumping water in the historical Horne mine from the surface.

Water from the Quemont mine will be pumped via the Quemont No. 2 shaft in accordance to the shaft rehabilitation rate (step 2a). The pumping installation on the Galloway will direct the water to the surface at first and then trough the main clear water pumping stations located at levels Q275, Q715 and Q1180 as soon as they become available.

Simultaneous to the Quemont mine dewatering, a surface pump installation will be installed on the collar of historical Horne No. 4 shaft (REMNOR). The combined dewatering flow rate from all sources will be performed at a maximum rate of 600 m<sup>3</sup>/h (step 2b). At this step, the priority is given to the rehabilitation of the Quemont No. 2 shaft. The dewatering rate on the Horne side will be adjusted to match the pumping capacities that are not used on the Quemont mine side to always maximize the flow of 600 m<sup>3</sup>/h to the WTP, which is the limit of the plant.

When reaching level Q385, the connection between the Quemont and Donalda mines must be secured by adding a hydrostatic barricade. The hydrostatic plug will be put in place remotely from the upper level drift on the Quemont side, even if an existing barricade is already in place. This new barricade close to the Quemont shaft will provide extra safety.

The volume of water pumped during this step is estimated at 0.56 Mm<sup>3</sup> at the Quemont mine and 4 Mm<sup>3</sup> at the Horne mine. The duration of this dewatering step is estimated at 12 months (364 days).

The water treatment sludge generated at this step will be disposed and stored in the Donalda mine underground workings. The cumulative volume of water treatment sludge stored at the Donalda mine will be 156,900 m<sup>3</sup> (at 35% solids). The details of the dewatering and sludge disposal activities for this step are presented in Figure 16-17.

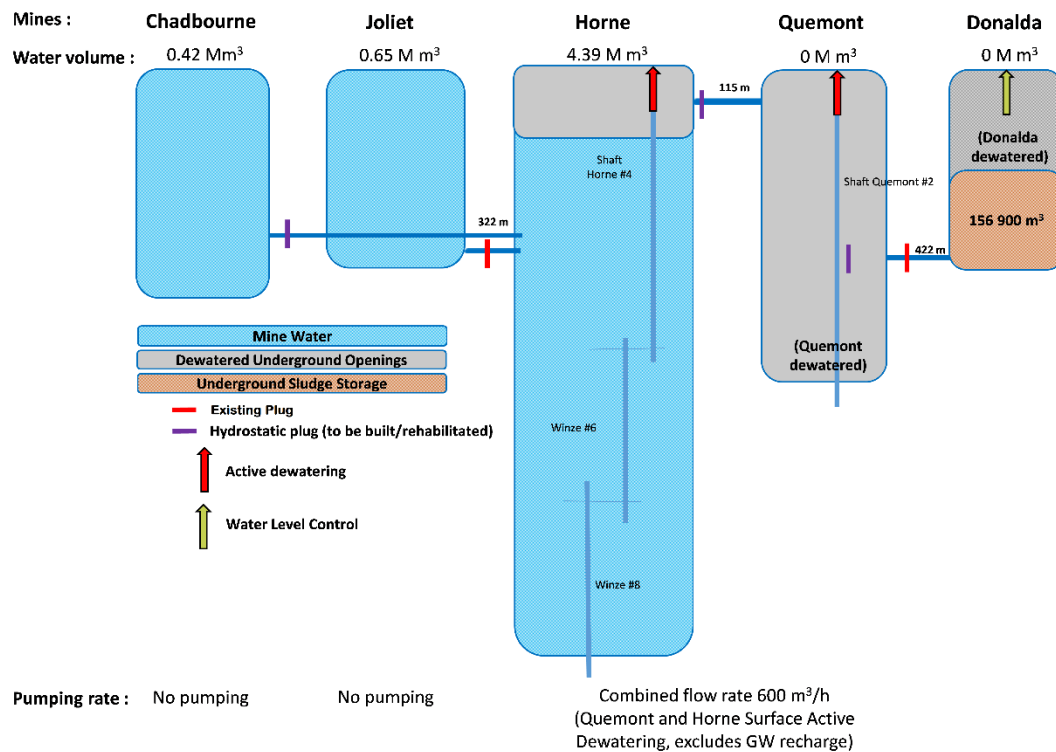

Figure 16-17: Final conditions of dewatering – step 2

Along the rehabilitation to the bottom of the Quemont No. 2 shaft, existing Quemont stations are rehabilitated to allow minimum space to work and build barricades to isolate and secure Quemont No. 2 shaft from potential water inflow coming from historical Quemont Mine stopes. Barricades are hydrostatics and are built with a high safety factor and equipped with proper instrumentation, electric services and drainages network for water and slurry storage. The historical Quemont mine will be used to store sludge coming from the water treatment and non-treated water that will be used for the start-up of the process plant.

On selected Quemont levels, rehabilitation is pushed further to reach the historical ventilation system. The Quemont ventilation system will be used in the preproduction phase until the new ventilation system is ready (see ventilation section for more information).

The new shaft stations are also built as soon as possible along the rehabilitation of the Quemont No. 2 shaft. Priority is given to electric and permanent pumping stations as the pumping stations will be used during the dewatering phase to pump water to the surface, see Section 16.5 for more information on shaft access.

#### 16.4.5.3 Step 3 (3a, 3b and 3c)

The third dewatering step is the dewatering of the Horne deeper portion of the mine (>230 m depth). After completion of the Quemont No. 2 shaft rehabilitation and construction of the main pumping stations, all pumping capacity will be used to dewater the historical Horne mine to L1310 (bottom of Phase 1 of Horne 5 Project). A drainage system will be put in place to direct all the water from historical Horne to the main pumping stations installed near the Quemont No. 2 shaft via inclined boreholes drilled from three new developed drifts connecting the Quemont No. 2 shaft to the Horne 5 mine. These are the future main levels: L322 (ventilation level), L790 and L1190 (connecting with conveyor drifts at L1270).

For each of these three drainage system, about ten 250 m long, 3 inch diameter holes will be drilled to reach the Horne mine's existing excavations. The drained water will be directed to the main pumping stations with pumps located in the drilling bays. The pumping flow rate for dewatering the rest of the historical Horne mine will reach the maximum capacity of the WTP (600 m<sup>3</sup>/h).

The historical Horne drainage will start at level L322 (step 3a). When the flow in the drilled holes becomes less than 600 m<sup>3</sup>/h, the drainage system on L790 must be functional to accept new drainage installation at lower levels (step 3b). When the flow in the drilled holes becomes less than 600 m<sup>3</sup>/h, the drainage system on L1190 must be functional to accept new drainage installation at lower levels (step 3c).

The volume of water pumped during this step is estimated at 4.2 Mm<sup>3</sup> at historical Horne Mine. The water treatment sludge disposal will continue in the Donalda mine underground workings until the available volume is reached. The duration of this dewatering step is estimated to last 10 months.

The cumulative treatment sludges volume of water stored in the Donalda mine is estimated at 294,600 m<sup>3</sup> (at 35% solids). Once the available volume for sludge is reached in the Donalda mine and the Quemont No.2 shaft is completely isolated from the Quemont mine by barricades, the sludge will be managed in the Quemont mine underground workings. The sludge disposal will also be done using boreholes and a pumping system from the surface. A volume of about 445,900 m<sup>3</sup> of sludge will be stored at the Quemont mine. At the end of this dewatering step, the remaining volume of water from the Horne mine (approximately 1.55 Mm<sup>3</sup>) will be pumped directly into the Quemont underground workings without being treated. This water will later be reclaimed for the Horne 5 process plant during production when the surface TMF is operating. The details of the dewatering and sludge disposal activities for this step are presented in Figure 16-18.

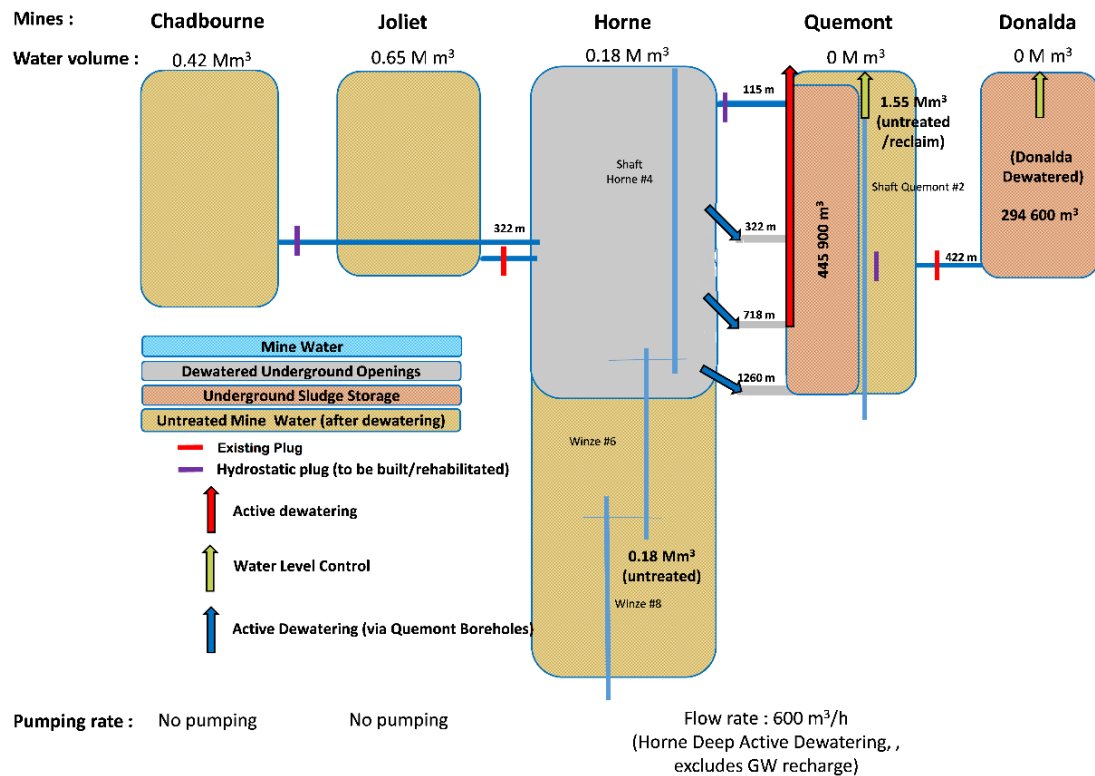

Figure 16-18: Final conditions of dewatering – step 3

#### 16.4.5.4 Step 4 (4a and 4b)

Phase 1 of production ends at level L1310. Dewatering from L1190 to the bottom of Phase 1 will be done by remote drainage using DDH from new development with the development sequence progression (step 4a).

Deeper than level L1310, the dewatering will adjust to the mine development of Phase 2 production (step 4b).

#### 16.4.6 Dewatering Schedule

Required pumping days for each step are as follows:

- Step 1, 131 pumping days – Quemont No. 2 and Donalda shaft reach level Q275;
- Step 2a, 273 pumping days – Quemont No. 2 shaft rehab and dewatering is completed (Q1180);
- Step 2b, 364 pumping days – Horne No. 4 shaft dewatering from surface to 230 m deep, period based on a 600 m<sup>3</sup>/h pumping rate. Simultaneous with step 2a, priority is given to the Quemont No. 2 shaft rehabilitation;
- Step 3 (3a,b,c), 326 pumping days – Horne dewatering by drainage to L1190;
- Step 4 (4a,b) in accordance to development schedules of Phase 1 and Phase 2.

The dewatering schedule for the Project follows the recommendations in the underground mine dewatering guide of the AMQ to consider some of the possible risks such as water level changes, poor condition of old constructions, unstable ground support, ventilation issues and unexpected voids.



		2018																																			
		January			February			March			April			May			June			July			August			September			October			November			December		
		10	20	31	41	51	59	69	79	90	100	110	120	130	140	151	161	171	181	191	201	212	222	232	243	253	263	273	283	293	304	314	324	334	344	354	365
		10	20	31	41	51	59	69	79	90	100	110	120	130	140	151	161	171	181	191	201	212	222	232	243	253	263	273	283	293	304	314	324	334	344	354	365
Shaft (3m/day)	0 to Q275 (275m + 50m d'avance + rehab station)	111																																			
	Q275 to Q715 (440m + rehab station)	133																																			
	Q715 to Q1240 (525m + rehab station)	0																																			
	<b>Total</b>	<b>244</b>																																			
Developpement	Q275 and L322 (437m at dev. rate of 4m/day + const.)	133																																			
	Q715 and L774 (394m at dev. rate of 4m/day + const.)	0																																			
	Q1180, L1194 and L1269 (413m at dev. rate of 4m/day + const.)	0																																			
	<b>Total</b>	<b>133</b>																																			
Quemont Dewatering	0 to Q275 (600m <sup>3</sup> /h split between Quemont 450m <sup>3</sup> /h-Donalda 150m <sup>3</sup> /h)	131																																			
	Q275 to Q715 (Pumping with shaft rehab rate at 195m <sup>3</sup> /h)	133																																			
	Q715 to Q1240 (Pumping with shaft rehab rate at 30m <sup>3</sup> /h)	0																																			
	<b>Total</b>	<b>264</b>																																			
Horne Dewatering	0-230m from surface in Horne 5 at 405m <sup>3</sup> /h-570m <sup>3</sup> /h-600m <sup>3</sup> /h	164																																			
	230m from surface to L322 (UG) at 600m <sup>3</sup> /h	0																																			
	L322 to L774 (UG) at 600m <sup>3</sup> /h	0																																			
	L774 to L1269 (UG) at 600m <sup>3</sup> /h	0																																			
<b>Total</b>	<b>164</b>																																				

		2019																																			
		January			February			March			April			May			June			July			August			September			October			November			December		
		10	20	31	41	51	59	69	79	90	100	110	120	130	140	151	161	171	181	191	201	212	222	232	243	253	263	273	283	293	304	314	324	334	344	354	365
		375	385	396	406	416	424	434	444	455	465	475	485	495	505	516	526	536	546	556	566	577	587	597	608	618	628	638	648	658	669	679	689	699	709	719	730
Shaft (3m/day)	0 to Q275 (275m + 50m d'avance + rehab station)	0																																			
	Q275 to Q715 (440m + rehab station)	51																																			
	Q715 to Q1240 (525m + rehab station)	222																																			
	<b>Total</b>	<b>273</b>																																			
Developpement	Q275 and L322 (437m at dev. rate of 4m/day + const.)	36																																			
	Q715 and L774 (394m at dev. rate of 4m/day + const.)	159																																			
	Q1180, L1194 and L1269 (413m at dev. rate of 4m/day + const.)	72																																			
	<b>Total</b>	<b>267</b>																																			
Quemont Dewatering	0 to Q275 (600m <sup>3</sup> /h split between Quemont 450m <sup>3</sup> /h-Donalda 150m <sup>3</sup> /h)	0																																			
	Q275 to Q715 (Pumping with shaft rehab rate at 195m <sup>3</sup> /h)	10																																			
	Q715 to Q1240 (Pumping with shaft rehab rate at 30m <sup>3</sup> /h)	130																																			
	<b>Total</b>	<b>140</b>																																			
Horne Dewatering	0-230m from surface in Horne 5 at 405m <sup>3</sup> /h-570m <sup>3</sup> /h-600m <sup>3</sup> /h	200																																			
	230m from surface to L322 (UG) at 600m <sup>3</sup> /h	77																																			
	L322 to L774 (UG) at 600m <sup>3</sup> /h	82																																			
	L774 to L1269 (UG) at 600m <sup>3</sup> /h	0																																			
<b>Total</b>	<b>359</b>																																				

		2020																																			
		January			February			March			April			May			June			July			August			September			October			November			December		
		10	20	31	41	51	59	69	79	90	100	110	120	130	140	151	161	171	181	191	201	212	222	232	243	253	263	273	283	293	304	314	324	334	344	354	365
		740	750	761	771	781	789	799	809	820	830	840	850	860	870	881	891	901	911	921	931	942	952	962	973	983	993	1003	1013	1023	1034	1044	1054	1064	1074	1084	1095
Shaft (3m/day)	0 to Q275 (275m + 50m d'avance + rehab station)	0																																			
	Q275 to Q715 (440m + rehab station)	0																																			
	Q715 to Q1240 (525m + rehab station)	0																																			
	<b>Total</b>	<b>0</b>																																			
Developpement	Q275 and L322 (437m at dev. rate of 4m/day + const.)	0																																			
	Q715 and L774 (394m at dev. rate of 4m/day + const.)	0																																			
	Q1180, L1194 and L1269 (413m at dev. rate of 4m/day + const.)	91																																			
	<b>Total</b>	<b>91</b>																																			
Quemont Dewatering	0 to Q275 (600m <sup>3</sup> /h split between Quemont 450m <sup>3</sup> /h-Donalda 150m <sup>3</sup> /h)	0																																			
	Q275 to Q715 (Pumping with shaft rehab rate at 195m <sup>3</sup> /h)	0																																			
	Q715 to Q1240 (Pumping with shaft rehab rate at 30m <sup>3</sup> /h)	0																																			
	<b>Total</b>	<b>0</b>																																			
Horne Dewatering	0-230m from surface in Horne 5 at 405m <sup>3</sup> /h-570m <sup>3</sup> /h-600m <sup>3</sup> /h	0																																			
	230m from surface to L322 (UG) at 600m <sup>3</sup> /h	0																																			
	L322 to L774 (UG) at 600m <sup>3</sup> /h	95																																			
	L774 to L1269 (UG) at 600m <sup>3</sup> /h	73																																			
<b>Total</b>	<b>167</b>																																				

Figure 16-19: Dewatering schedule



## 16.5 Mine Services

### 16.5.1 Electrical Distribution

#### 16.5.1.1 Preproduction Phase, Dewatering

During the dewatering period, three sets of electrical stations (1.5 MVA, 13.8 kV-600 V) are required to power three lines of submersible pumps. These stations will be dedicated to dewatering activities and will be located at the surface sites of the Horne, Quemont and Donalda mines. At the Donalda site, a 25 kV connection to the Hydro-Québec system will be required for the duration of the dewatering period.

In addition, the dewatering period will require the following installations:

- One temporary electrical station (1.5 MVA, 13.8 kV-600 V) to power the temporary pumping stations (500 hp) to drain the historical Horne mine;
- Three permanent electrical stations (2 MVA, 13.8 kV-600 V) to power the clear water permanent pumping stations on levels Q275 (1,200 hp), Q715 (1,400 hp) and Q1180 (1,400 hp).

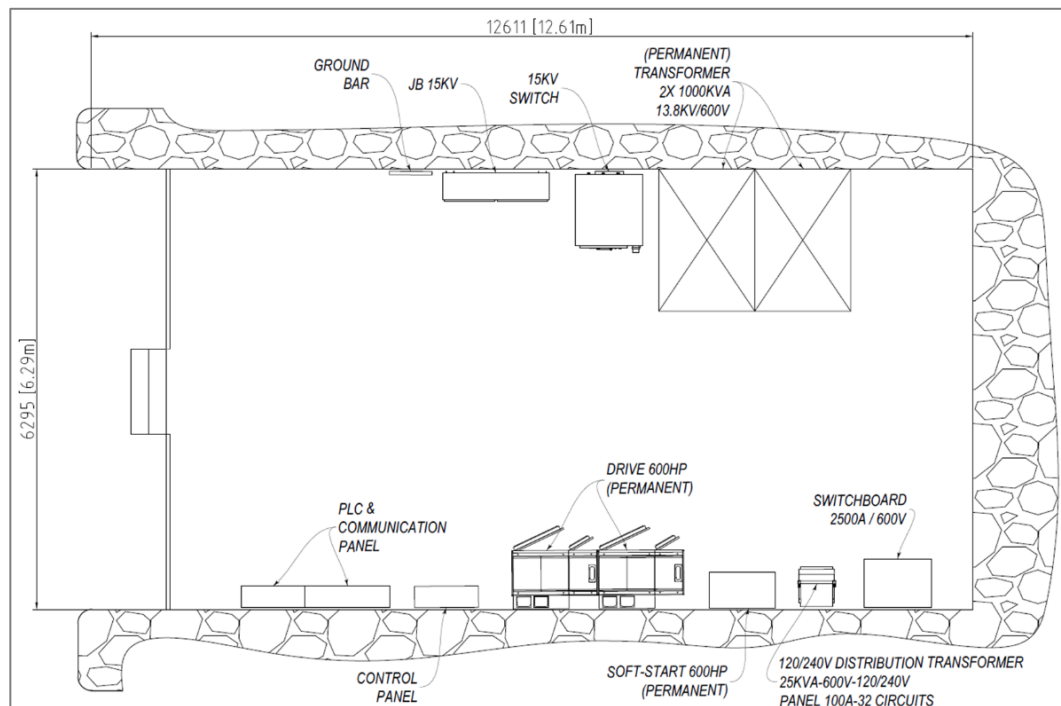

Figure 16-20: Q275, Q715 and Q1180, Typical permanent electrical station

All these electrical stations will be installed underground and sent in sections due to the Quemont No. 2 shaft's limitations with respect to weight and dimensions. All the variable frequency drives (VFD) and soft motor starters (SMS) for pumping will be installed at the same location and connected to the pumping system.

Each barricade along the Quemont No. 2 shaft will be fed with a 600V electrical distribution panel for supplying power to instrumentation, lighting and equipment for rehabilitation work. These electrical installations are permanent.

The ventilation fans installed during the dewatering phase will be powered and controlled by the electrical stations available on levels Q275, Q715 and Q1180. All the VFDs required to control fans during this phase will be installed at the same location and connected to the ventilation system.

#### 16.5.1.2 Production Phase 1 and Phase 2

During the production phases, 13.8 kV power cables coming from the shaft will feed all the underground main electrical stations and production substations. These cables will feed different load zones of the underground mine, providing reliability, load balance and limiting the loading of the feeders as well as the voltage drop at the end of the line. In case of emergency or fault in one of the feeders, the electrical stations will be transferred to another power feeder, limiting the loss of production.

The following list describes each permanent electrical installation required during the production phases:

- One station on each of the levels Q275, Q715, Q1180 and Q1851 near the Quemont No. 2 shaft to supply the permanent clear water pumping stations, permanent dirty water pumping stations and other permanent installations located nearby.
- One station on level Q1491 to supply the clear water permanent booster pumping station;
- One station each on levels Q1135 and Q1821 near the Quemont No. 2 shaft to supply the water clarifiers, the permanent sludge pumping stations and other permanent installations located nearby;
- One station on level Q550 to supply the permanent sludge booster pumping station;
- One station each on levels Q1197 and Q1911 near the Quemont No. 2 shaft to supply the permanent shaft-bottom dirty water pumping stations;
- One each on levels L1270, L1940, L2000 and L2060 to supply the production dirty water pumping stations;
- One station on level L322 to supply the main ventilation fans;

- One station each on levels L1270, L1310, Q1135, L1910 and L1940 to supply the material handling installations, such as the crushers, the grizzlies, the conveyors and the rock breakers;
- One station on level L1190 to supply the garage service area installations.

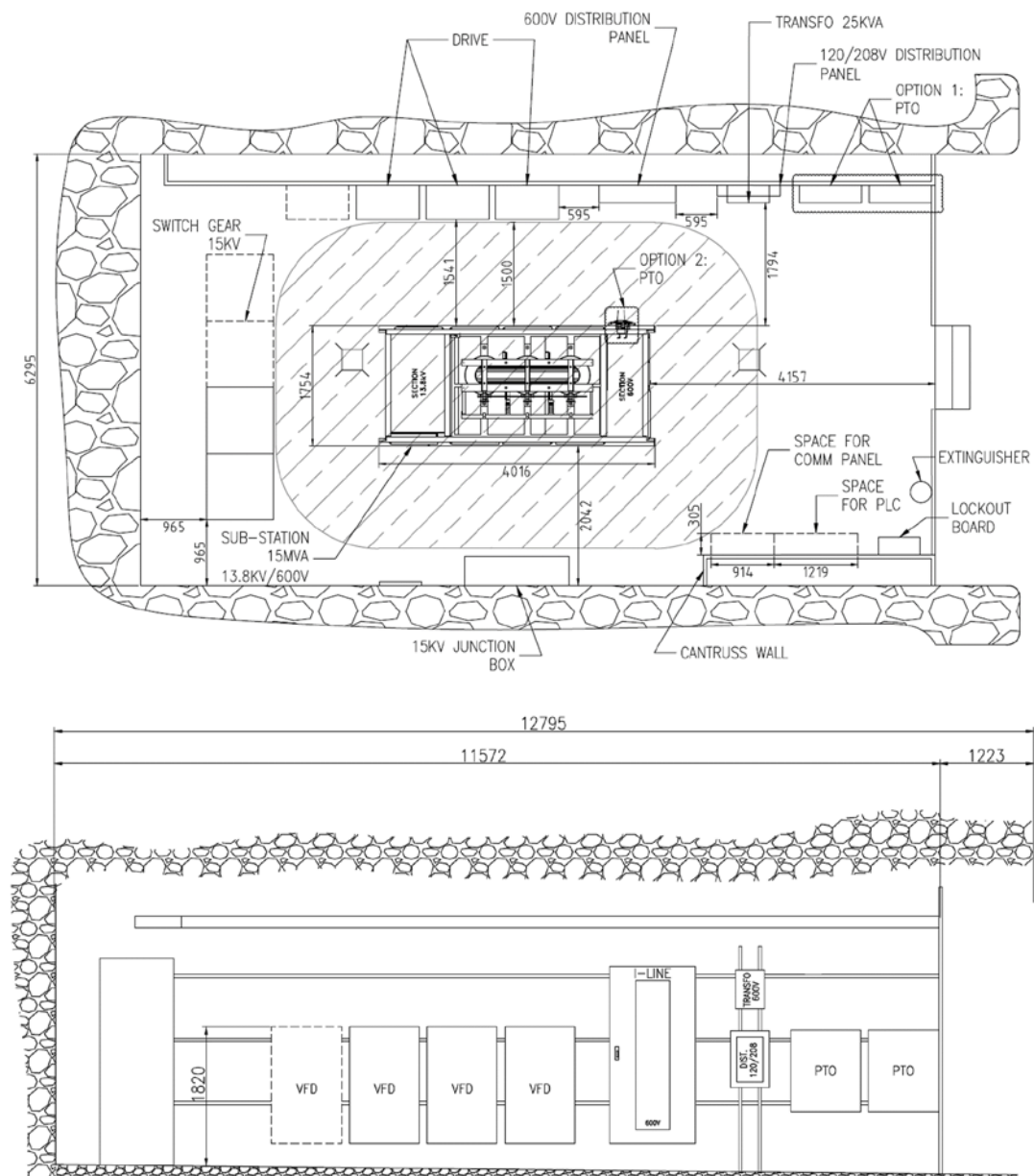

Figure 16-21: Typical permanent substation

---

In addition to the permanent electrical stations, each production level is supplied by a 13.8 kV electrical cable supplying power to a 13.8 kV / 600 V production electric substation. These production substations will power mobile equipment, automatic doors, secondary ventilation fans, storages, refuges, auxiliary pumps and other facilities.

When possible, on levels when production is finished, the electrical equipment will be moved to the next level that will start production

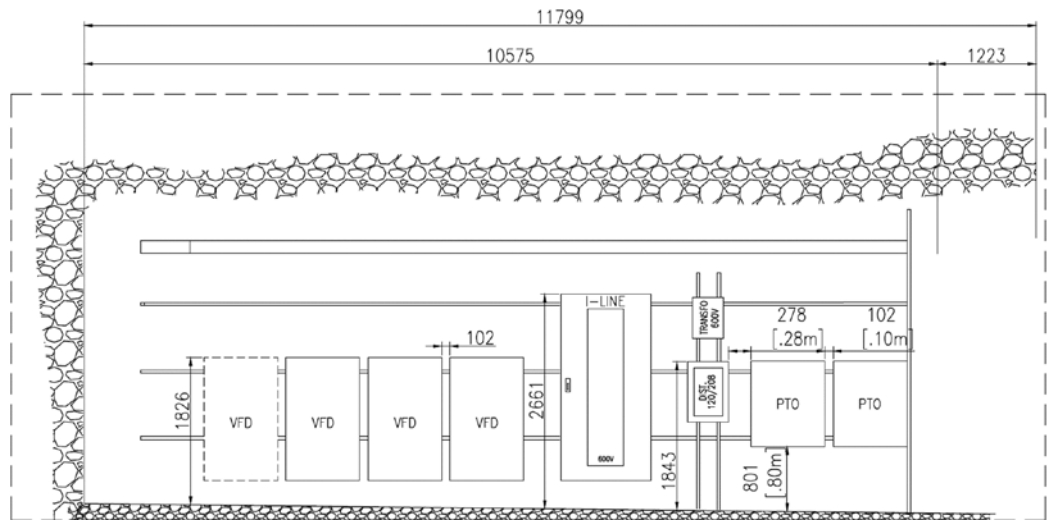
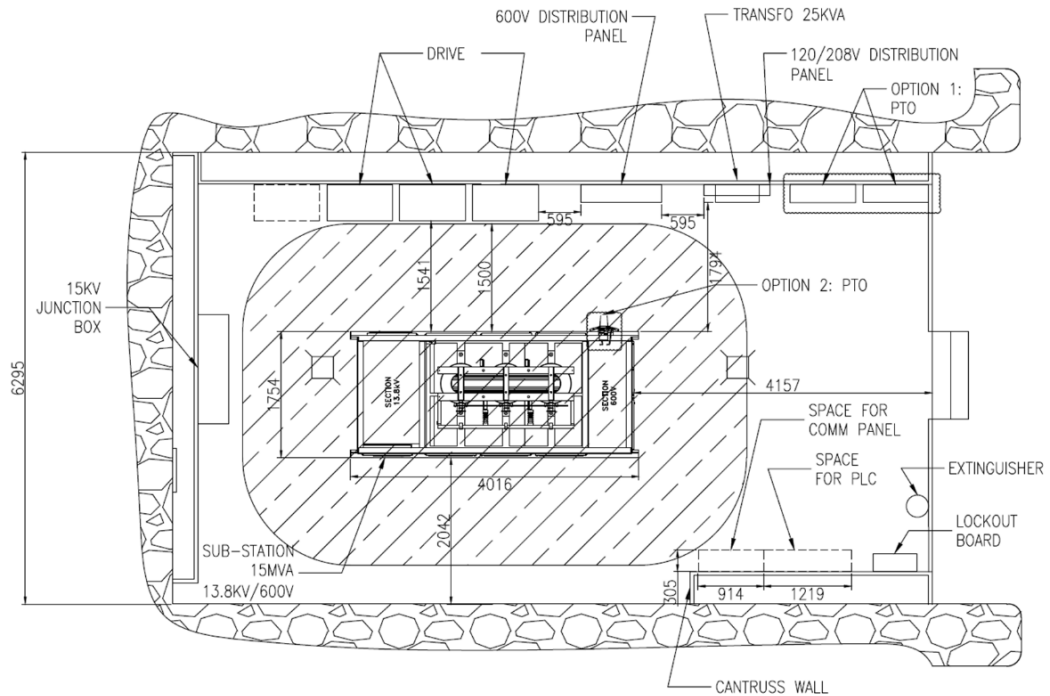

Figure 16-22: Typical production substation

---

### 16.5.2 Mine Automation and Monitoring Systems

As the Horne 5 Project will be highly automated, the communication network is critical. Each level will be equipped with WIFI communication and a network of access point will be installed through fibre optics and in addition, a leaky feeder communication system will also be installed. Three master networks will be installed from the surface to every underground level:

- Leaky feeder cables will provide voice communication throughout the mine. This network will be separated into multiple VLANs: administration, instrumentation, WIFI, tracking and other uses (except for live camera);
- “FEMCO” security system will be deployed at every refuge and strategic site. This second network will be dedicated to the operation and automation of ABB hoists;
- Fibre optic cables will be brought to every electrical substation, pumping station, crushing station, conveying facility and strategic site. This third network will be ready for all automation systems such as WIFI, PLC, automation of mobile vehicles, administrative network, cameras and others. A dedicated fibre optic cable will be used for the live cameras, as they require a very high bandwidth. The fibre optic network will pass in two separate cables in the shaft to create redundancy. When all the ramp segments will connect with each other, the network can be made redundant for added reliability.

Since the leaky feeder network can support both voice and data communication and can be rapidly deployed, this network will be used initially for all communications until the fibre optic network is installed. Also, Data Over Cable Service Interface Specification (“DOCSIS”) via the leaky feeder could provide a network where the fibre optic cable is not yet deployed and provides a limited redundant path in case of failure.

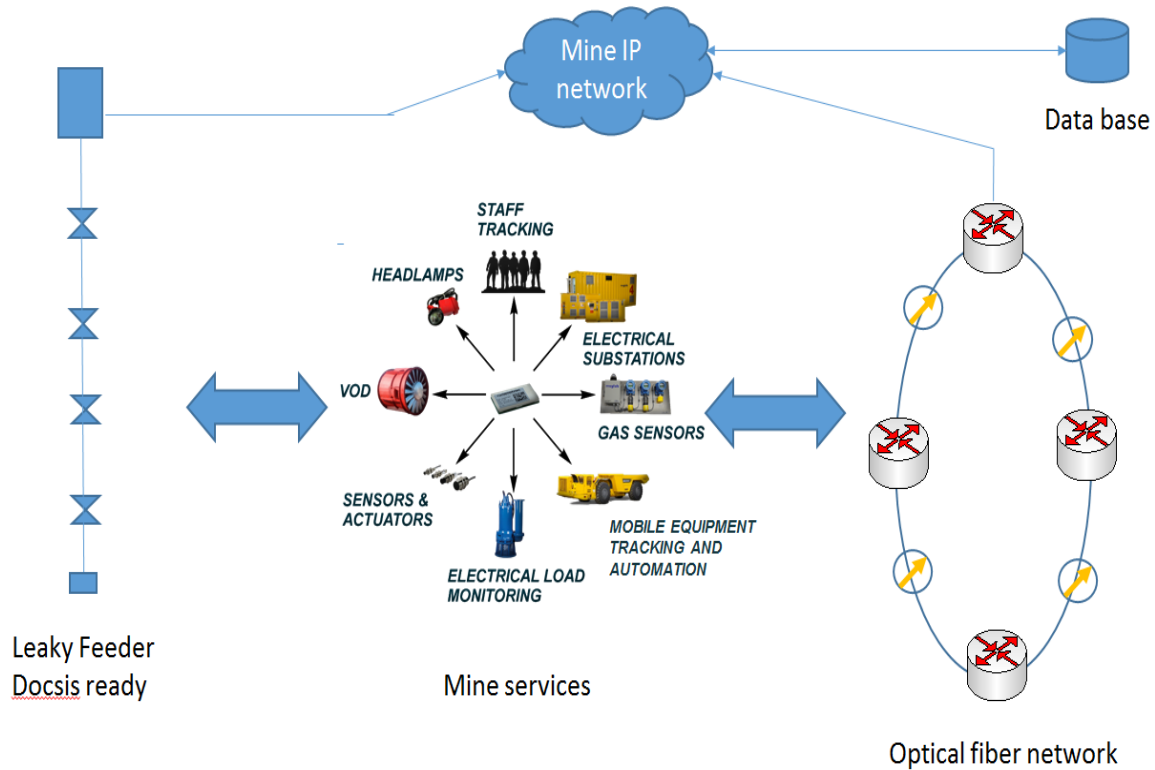

Figure 16-23: Fibre and leaky feeder networks

To automate the mine operations, there are several solutions that are going to be implemented such as:

- Ventilation on demand (“VOD”);
- Tele-operations (LHD, drill);
- Rock breaker automation;
- Hoists automation.

Other options could be implemented in the future, such as:

- Blasting with “smart blast” technology;
- Mobile equipment telemetry;
- Monitoring;
- Pumping station automation;
- etc.

The network presented above could support such implementations. The main data network, combined with the PLC (programmable logic controller) fibre and leaky feeder, will be able to transmit all information and control signals both ways between the surface and everywhere underground. This combination will reduce operating costs, improve network availability and reduce deployment time.

Furthermore, this system will improve security with the tagging system that relays the position of every piece of equipment and every worker or visitor underground.

### 16.5.3 Fuel Distribution Network

The annual fuel consumption for mobile equipment is estimated at approximately 4 million litres per year (4 ML/y). As per regulatory requirements, pipes need to be able to self-purge and the delivery of fuel into the mine must be gravity-driven, in this case along a 51 mm galvanized steel pipe in the Quemont No. 2 shaft. The fuel stations will be located on the main levels L1190 for Phase 1 and L1880 for Phase 2. Each fuel station will consist of a fuel storage tank, a batch fuel tank, and a distribution system. Connections on those levels will bring fuel to the fuel stations. As there is only one fuel station per phase, two fuel & lube trucks with a capacity of 9,000 L each will be dedicated to underground fuel distribution to mobile equipment on production levels throughout the mine.

It is expected that 77,000 L will be delivered to the mine site each week. Assuming biweekly deliveries, the fuel surface tank must have a storage capacity of 40,000 L and be equipped with spill-prevention features. Fuel will be sent underground in batches of 5,000 L, requiring the installation of three 5,000 L batch tanks, one on surface and the other two near the underground fuel storage tanks. Batch production will be fully automated, controlling the pumps that produce the batches. The underground fuel storage tanks will have a capacity of 15,000 L each to meet the capacity of the fuel trucks and some of the other mobile equipment. These tanks will be connected to a fast-fueling distribution system and will be equipped with spill-prevention features.

Each fuel station is equipped with a fire suppression system. Figure 16-24 shows a schematic of the fuel distribution network.



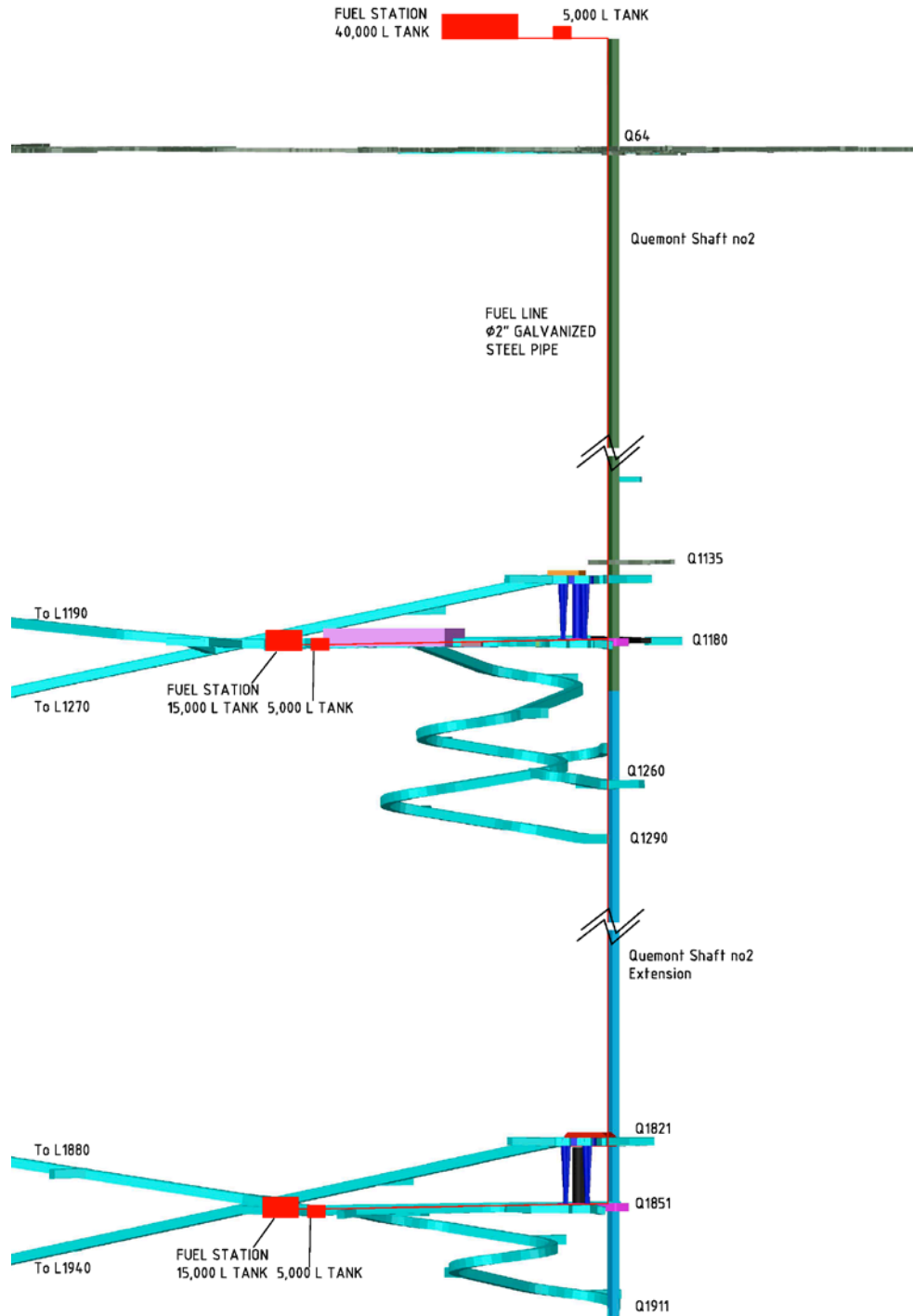

Figure 16-24: Schematic fuel distribution network

#### 16.5.4 Permanent Mine Pumping Network

The permanent mine dewatering network will be put in place as soon as possible to support the dewatering activities during the preproduction period. The final permanent pumping system during the production period consists of five main clear water pumping stations installed near the shaft stations for a lifting capacity of 275 m to 475 m, depending on each level's configuration. The three first main clear water pumping stations (Phase 1 of production) will be installed during the rehabilitation of the Quemont No. 2 shaft. Most of the volumes pumped will be clarified mine water with a maximum of 3% solid content.

Two main water clarification systems will be installed. These systems will clarify mine water in situ and separate solids from residual water coming from the backfilling process of the historical voids. The solid concentrate coming from the mine water clarification process will be pumped in a parallel dirty water dewatering network to available voids underground or ultimately to the surface for disposal.

##### 16.5.4.1 Permanent Pumping Capacity Sizing

The permanent mine dewatering network is designed to carry the peak flows from three sources:

- Dirty mine water coming from mining operations (3% to 15% solid content);
- Very dirty residual water coming principally from slurry backfilling (5% to 25% solid content);
- Recharge from underground (this water is considered to be clear).

The maximum anticipated peak flow is estimated to be 400 m<sup>3</sup>/h. The installed dewatering capacity will be 600 m<sup>3</sup>/h, allowing the pumps to run intermittently and allowing a reaction time for maintenance.

Dirty water from the mine operation will be pumped at a rate of 150 m<sup>3</sup>/h, when needed.

It is planned to standardize all pumps to the same size and model to reduce the number of different equipment and required spares, when possible.

#### 16.5.4.2 Permanent Pumping Network General Layout

Figure 16-25 shows the planned permanent pumping network general layout.

All dirty water coming from operations and from backfill processes will be directed via the following path:

1. By gravity to a sump on each production level.
2. By gravity via drain holes to a bigger accumulating sump, on L1270 for Phase 1 and L1940 for Phase 2.
3. Water from level L1310 and the crusher stations will be pumped to the accumulating sump on L1270.
4. Water from the accumulating sumps will be pumped by either low-head heavy duty submersible slurry pumps or by horizontal slurry pumps to the main water clarification stations.

These water clarification stations will be located near the Quemont No. 2 shaft on levels Q1180 during Phase 1 and Q1851, during Phase 2.

Once the dirty water is treated and clarified:

- The clear water will be pumped with multistage pumps to the next booster dewatering station located 300 m to 475 m above until the surface. Main clear water pumping stations are located on levels Q275, Q715, Q1180, Q1491 and Q1851.
- The solid concentrate that will be recovered from the water clarification stations will be pumped with a high-pressure piston diaphragm pump to a booster station. There are two solid concentrate pumping stations; one on level Q1135 for Phase 1 operations and the other on level Q1821 for Phase 2 operations. The solid concentrate piston diaphragm booster pump is located on level Q550. The solid concentrate will be pumped to historical voids.

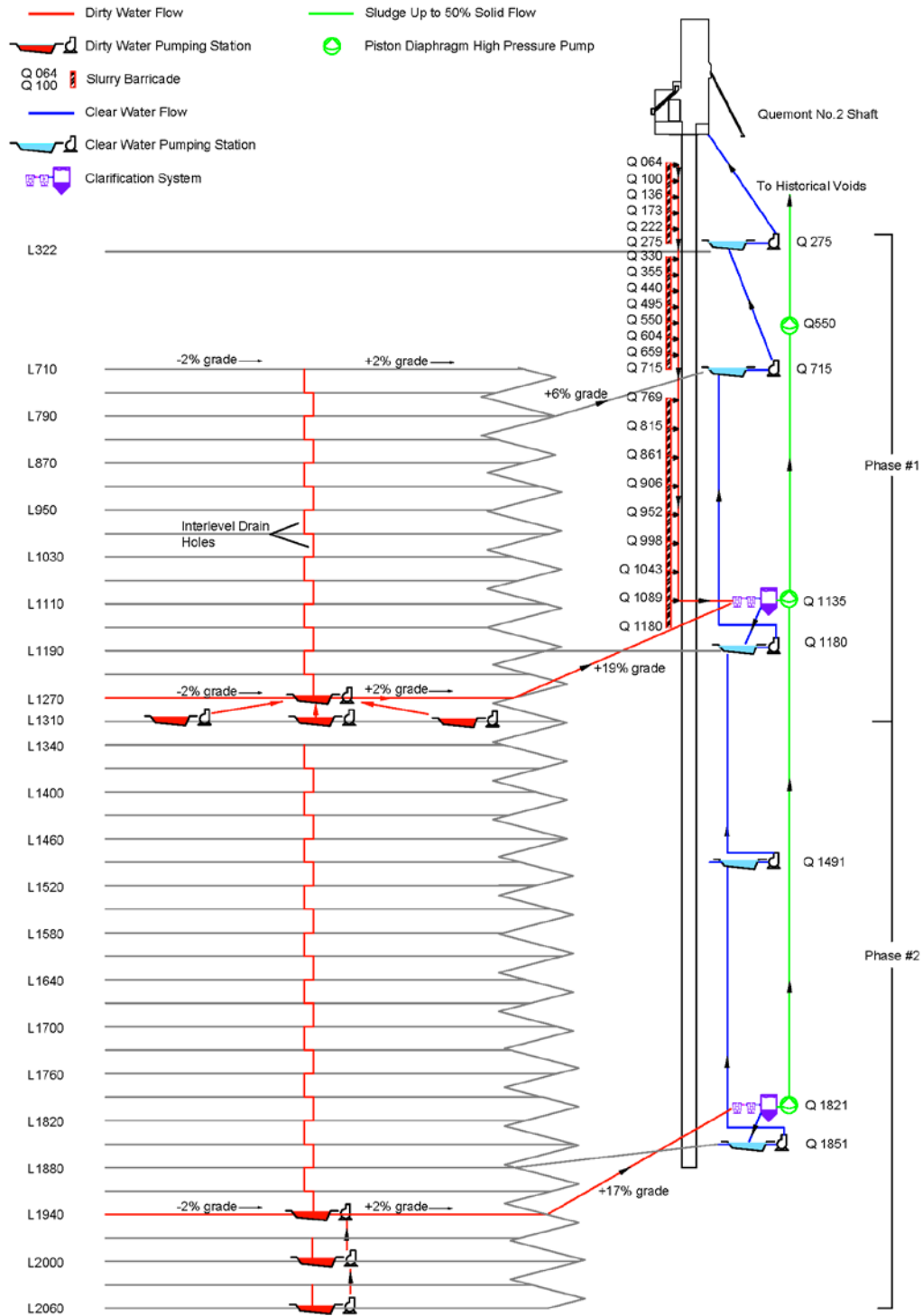

Figure 16-25: Permanent mine pumping network general layout

#### 16.5.4.3 Dirty Water Collection Network

All dirty water coming from mining operations, water seeping from stope backfill and slurry backfilling barricades will be transferred by gravity to various pumping stations and pumped to the water clarification stations.

Residual dirty seepage water from slurries that are disposed in the historical Quemont mine's voids will be collected out of slurry backfilling barricades in sumps at the base of each barricade. The water will then transferred by gravity to a drain pipe in the Quemont No. 2 shaft to the main water clarification stations.

At mining faces and in the stopes, water will run on each production level with a -2% grade to a dirty water sump and into the inter-level mine drain hole system for collection at the main sump located on level L1270 for Phase 1 and on level L1940 for Phase 2. These main collecting sumps will be connected to dirty water pumping stations that will pump the dirty water through the conveyor drifts for treatment at the main water clarification stations.

On level L1310, two pumps will be installed in sumps close to the crushers and one near the production drifts. These three pumps will send the water up to the main collecting sump and to the dirty water pumping station on level L1270.

During Phase 2, since there are five levels lower than L1910, pumping stations will be built on levels L2000 and L2060 to send the mine water to the L1940 main collecting sump and dirty water pumping station.

#### 16.5.4.4 Permanent Clear Water Pumping Station Layout

Clarified water from the water clarification stations will be collected in sumps at the clear water pumping stations. These retention sumps will have a capacity of 45 minutes or 450 m<sup>3</sup>. To keep the pump suction in flooded conditions, the sumps will be confined with a concrete wall. During Phase 1 of production, the clear water pumping stations will be equipped with three pumps installed in parallel, two in operation and one on stand-by for emergency or maintenance. Each pump capacity is 300 m<sup>3</sup>/h and is equipped with a 600 hp electric motor at 1,800 RPM.

On the lower levels of Phase 2 production, two pumps will be installed in parallel, one in operation and one on stand-by. Each pump capacity is 150 m<sup>3</sup>/h and is equipped with a 400 hp electric motor at 1,800 RPM.

Figure 16-26 shows the planned layout of a permanent clear water pumping station for Phase 1 of production.

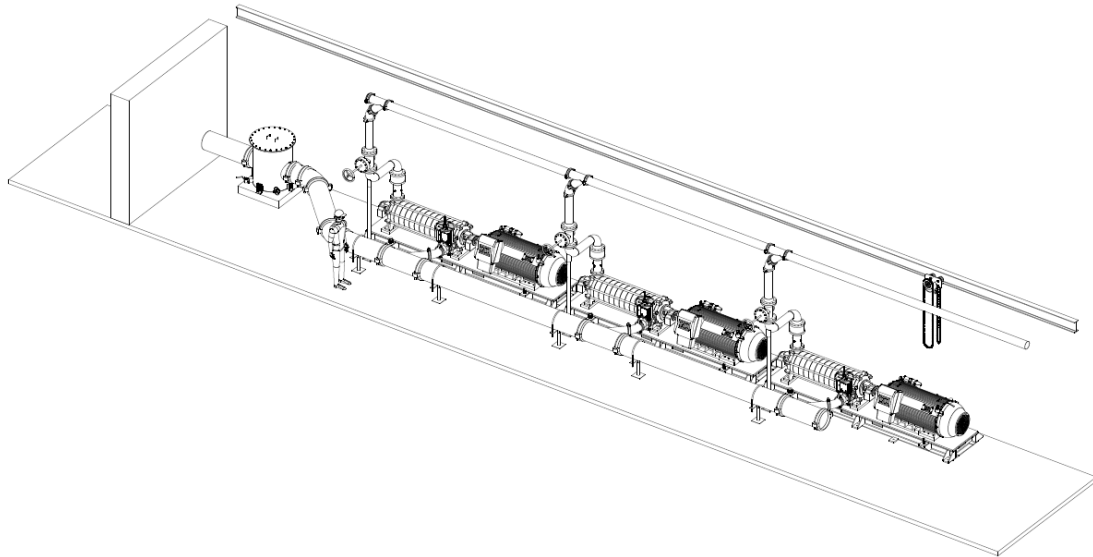

Figure 16-26: Permanent clear water pumping station layout

Pump types are to be multistage high pressure full duplex stainless steel. Figure 16-27 is showing a typical underground multistage pump dewatering station.



Figure 16-27: Typical underground multistage pump dewatering station

#### 16.5.4.5 Main Clarification Station Process Diagram

To treat and clarify the dirty water, Technosub's Mudwizard technology was selected. Dirty water collected from production levels will be stored in a conditioning tank for proper agitation. A constant speed stationary slurry feed pump will direct water into the clarification units for contact with the clarification agent (polymer). The mixture is then agitated in static mixers to initiate coagulation and the flocculation process. Two cone sumps of a minimum capacity of 250 m<sup>3</sup> are required to settle the mixture. Cone sumps are located near the Quemont No. 2 shaft between :

- Levels Q1135 and Q1180 for Phase 1;
- Levels Q1821 and Q1851 for Phase 2.

The overflow from the cone sumps, considered clarified at a maximum solid content of 3% solids, will be directed to the clear water holding sumps for transfer to high pressure dewatering multistage pumps. The concentrated solids at the underflow of the cone sumps (up to 50% solids) will be pumped with submersible pumps to an agitated holding tank that will feed the high-pressure piston diaphragm pumps, which will send the concentrated solids to historical voids.

Figure 16-28 shows the process diagram for the permanent dirty water clarification station.

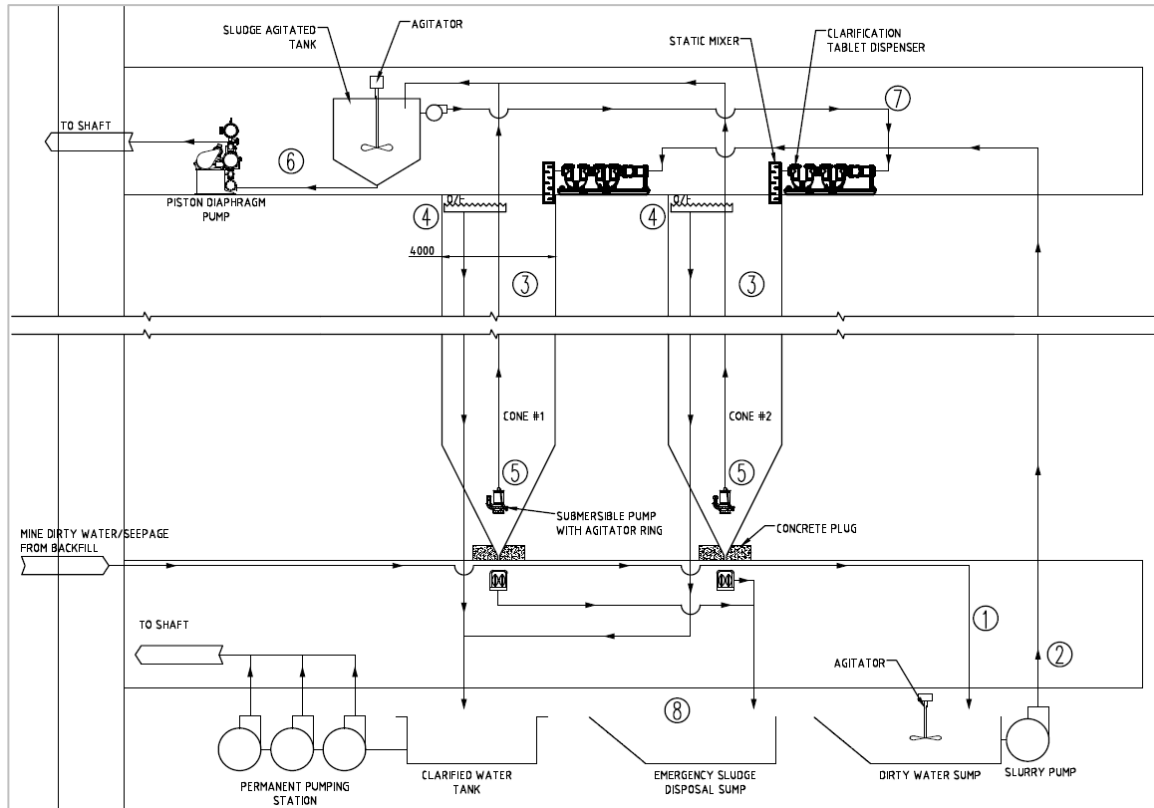

Figure 16-28: Conceptual clarification station process diagram

#### 16.5.4.6 Solid Disposal Network Layout

Solids recovered from the main clarification stations will be pumped via the Quemont No. 2 shaft in a parallel, rubber lined, dewatering pipe. It will be critical to maintain a pumping rate above the settling velocity to avoid the risk of sanding in the pipeline.

High pressure piston diaphragm pumps of 350 hp will be used to handle solid concentrations of variable density per mine conditions. The pump selection is standard for all installations:

- Clarification station in Phase 1 near the Quemont No. 2 shaft on level Q1135;
- Clarification station in Phase 2 near the Quemont No. 2 shaft on level Q1821;
- A booster pump at level Q550 to pump the concentrate to the surface or in a higher portion of existing historical voids.

Figure 16-25 shows the solid disposal network layout.



## 16.5.5 Ventilation Network

### 16.5.5.1 Dewatering and Rehabilitation Period Ventilation

The ventilation requirements during the dewatering and rehabilitation periods are regulated in Québec according to the *Regulation respecting occupational health and safety in mines*, Chapter S-2.1, r.14. In summary, four items have to be respected to estimate the airflow requirements:

- Prescribed airflow volume for diesel equipment;
- Minimum airflow per worker;
- Minimum airflow per worker per work station;
- Minimum air velocity per work station.

As few diesel equipment will be used during this period, a total of 55,000 cfm are required. This airflow will be sufficient for rehabilitation work in the shaft, on the levels and for mucking the new ventilation raise (CVE-AF3-Q64-Surf). This period comprises three steps with step 1 at 15,000 cfm to step 3 at 55,000 cfm.

During this first step, a 50 hp fan will be installed on the surface to provide between 15,000 cfm and 30,000 cfm for the Quemont No. 2 shaft down to the level Q64 station. (Figure 16-29).

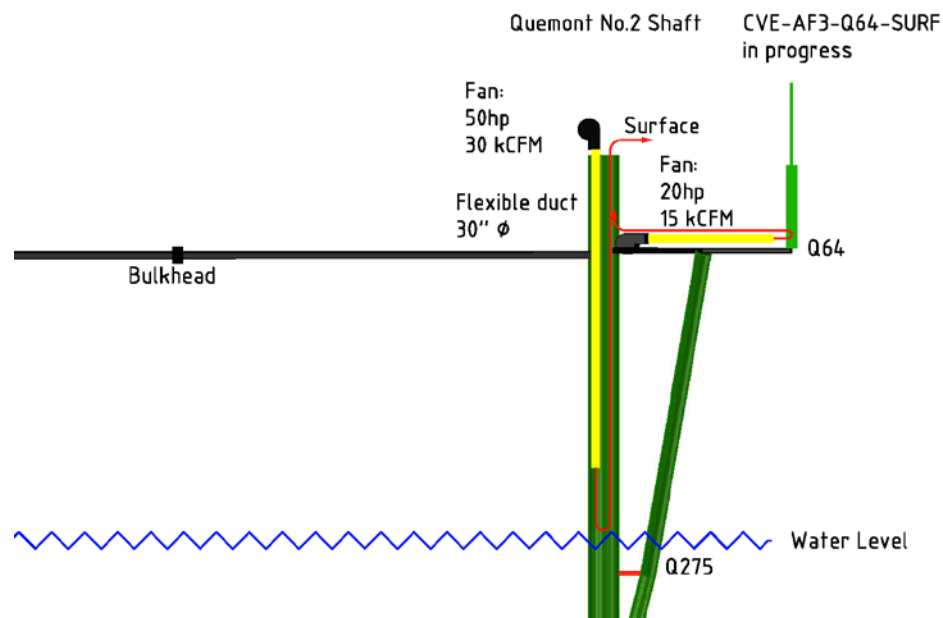

Figure 16-29: Dewatering and rehabilitation ventilation – step 1

Once level L115 becomes accessible for rehabilitation from the Quemont No. 2 shaft, a 20 hp fan will be installed at the shaft station to reuse air from the shaft. At this stage, the work force can start to be deployed to rehabilitate the level L115 and install barricades and temporary ventilation fans.

To convey air to the work places, a new ventilation raise will be required to replace a section of the historical Quemont ventilation raise from level L115 to the surface. At this stage, the first priority will be to raisebore a 3 m diameter ventilation raise (CVE-AF3-Q64-Surf) from surface to level L115 for rehabilitation activities to continue. This ventilation raise will connect with the historical Quemont ventilation network and will provide air to the bottom of the Quemont No. 2 shaft during shaft rehabilitation.

Once this new ventilation raise is completed, a temporary fan setup will be required on level L115. To minimize changeover and fan purchases, a 300 hp fan will be installed and the pitch adjusted to provide between 50,000 cfm and 60,000 cfm for the whole dewatering period. This fan will eventually provide up to 150,000 cfm during the development period. This underground installation will have the advantage to reduce noise at surface.

In the second step, the 50 hp fan on surface will then be relocated to the level L115 temporary fan station and rehabilitation of the Quemont No. 2 shaft will be ready to continue down to level L322. A temporary bulk-head will be installed just below level L115 in the historical Quemont ventilation raise to avoid air recirculation (Figure 16-30).

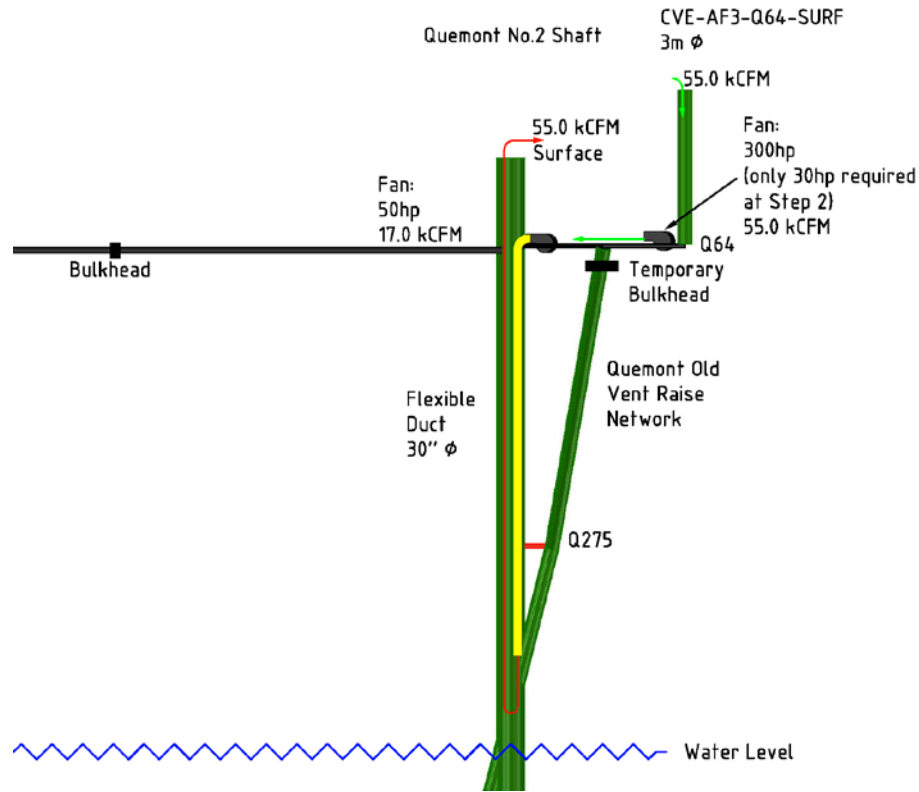

Figure 16-30: Dewatering and rehabilitation ventilation – step 2

In the final step, to complete the Queмонт No. 2 shaft rehabilitation, the 50 hp fan will follow the rehabilitation activities and will be moved approximately every 300 m to levels Q275, Q550 and Q861. Every time, a temporary bulk-head will be installed just below the level to avoid air recirculation (Figure 16-31).

On each historical Queмонт level between levels Q275, Q550 and Q861, a 15 hp fan will be installed at the shaft station to provide sufficient air flow for the historical level rehabilitation activities and the installation of the barricades. All accesses to the historical Queмонт ventilation raise must be sealed to avoid air recirculation.

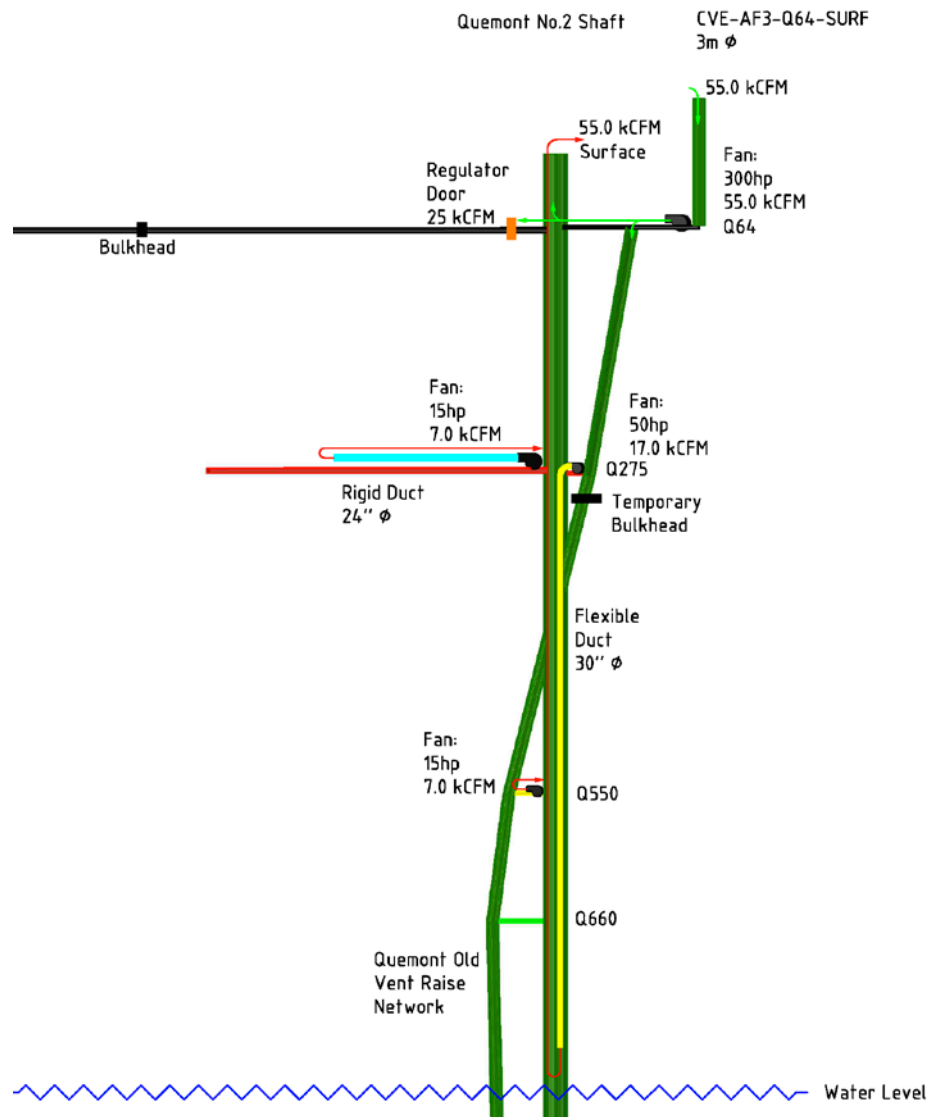

Figure 16-31: Dewatering and rehabilitation ventilation – step 3

The main objective of the dewatering and rehabilitation period is to reach and secure the historical Queumont ventilation network between level Q64 and level Q1180 and to avoid any air recirculation and undesirable leakages.

---

### 16.5.5.2 Preproduction Period Ventilation

The historical Quemont ventilation network will supply air flow through the shaft and to the development faces, and will avoid having air ducts in the shaft for secondary ventilation. The historical Quemont ventilation network has been retraced from historical mine plans and can provide most of the ventilation needs during the preproduction period to level Q1180. In parallel, during the dewatering and preproduction periods, the permanent ventilation network will be built as development progresses.

With the completion of level L322 rehabilitation, a 6 m diameter ventilation raisebore will be completed to connect the level L322 to the surface (CVW-AV6-L322-Surf). This new ventilation raise will provide sufficient airflow to support a development/construction crew on level L322 for the completion of the permanent ventilation and the dewatering infrastructure.

The construction of the main fans station will start as soon as the excavations will be ready. The main fans are installed underground to limit noise and disturbance on surface. Some development will also be done to allow the installation of the raiseboring equipment to complete the next ventilation raise down to level L790 (Figure 16-32).

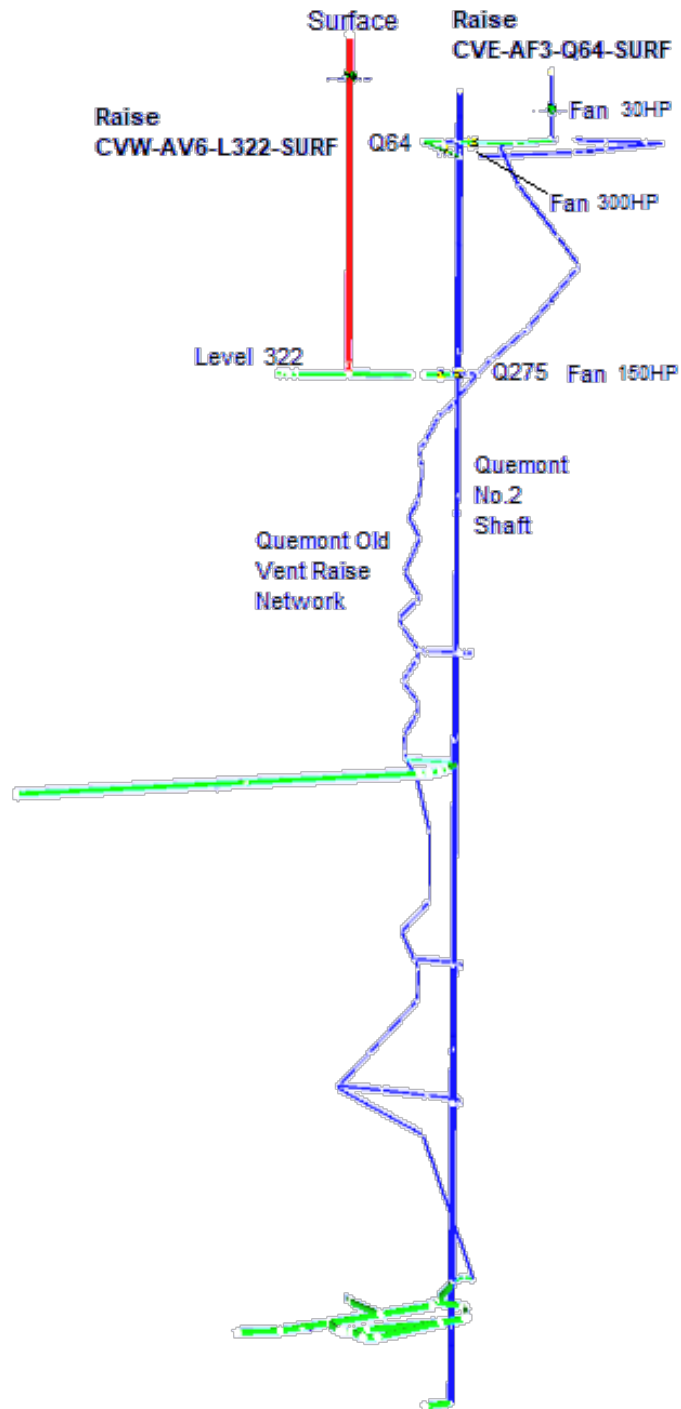

Figure 16-32: Preproduction ventilation network – level L322

When the dewatering of the historical Quemont mine and Quemont No. 2 shaft rehabilitation reach level L790, a second development crew will be deployed to develop the level L790 connection to the Horne 5 Project. Fresh air will be brought from the historical Quemont ventilation network until the bottom location of the new ventilation raise is reached on level L790. A 4 m diameter ventilation raisebore will be completed between level L790 and level L322 (CVE-AF4-L790-L322) to provide fresh air on the level.

The air flow will then run through :

- The 6 m diameter ventilation raisebore between surface and level L322 (CVW-AV6-L322-Surf);
- The permanent ventilation installation on level L322;
- The 4 m diameter ventilation raisebore between level L322 and level L790 (CVE-AF4-L790-L322);
- Exhausted by Quemont No. 2 shaft.

This network will provide an airflow of 165,000 cfm (Figure 16-33).

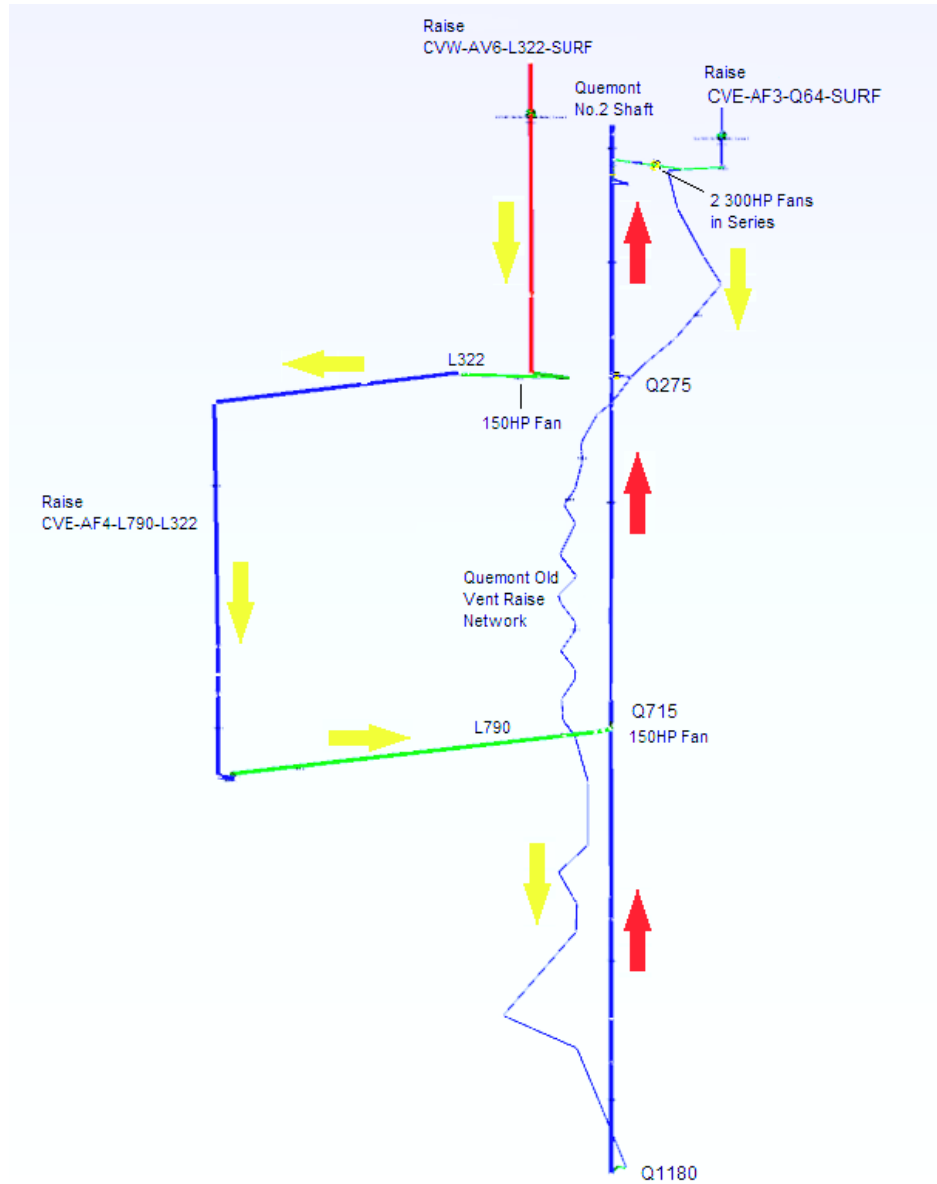

Figure 16-33: Preproduction ventilation network – level L790

When dewatering of the historical Quemont mine and Quemont No. 2 shaft rehabilitation reach level L1190, a third development crew will be deployed to develop the level L1190 connection to the Horne 5 Project. The development priority on level L1190 will be to access the start of the 4 m diameter ventilation raisebore (CVE-AF4-L1190-L790) that will connect to CVE-AF4-L790-L322 via a transfer drift on level L790.



Once the ventilation developments are completed on level L1190, 335,000 cfm will be available and a total of five development crews will be deployed underground (Figure 16-34).

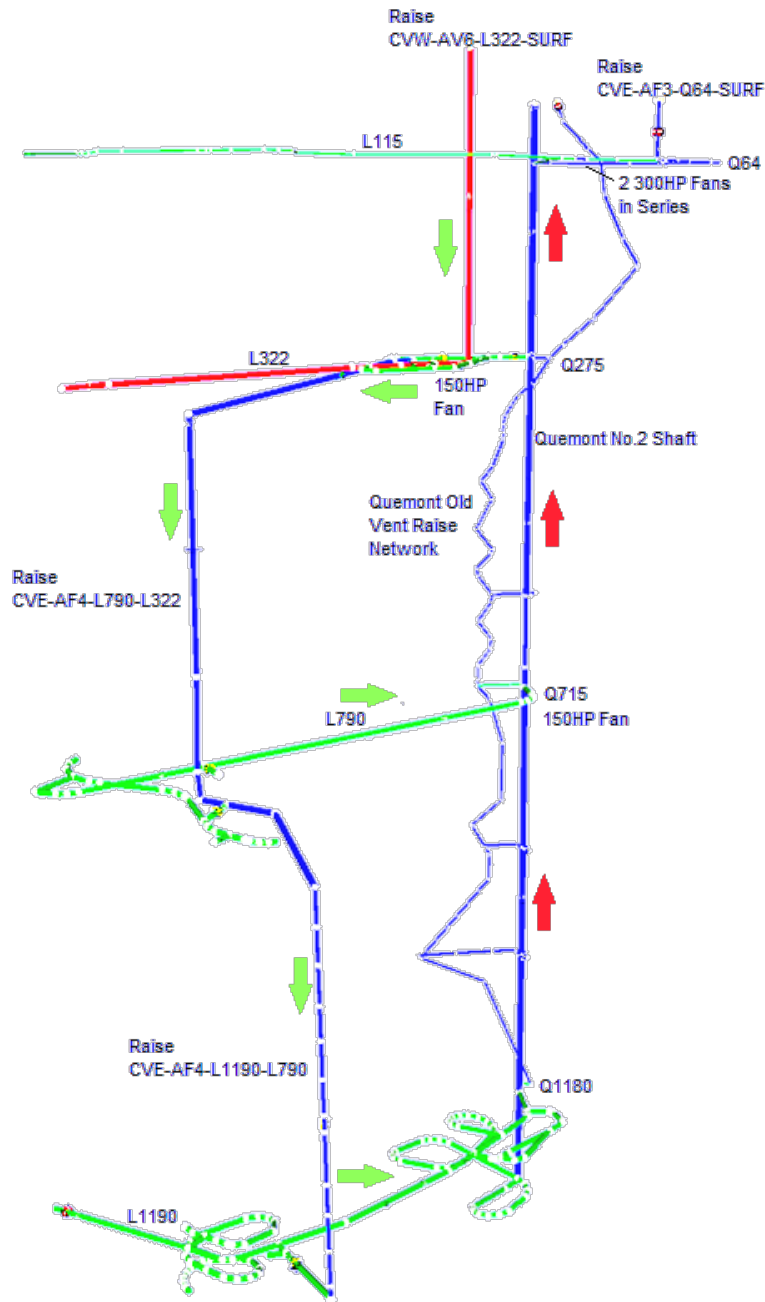

Figure 16-34: Preproduction ventilation network – level L1190

---

The following developments must be completed to commission one of the two exhaust fans (150 hp) on level L322 :

- Two 5 m diameter ventilation raisebores between level L790, level L322 and surface;
- The development on the exhaust airway side on level L322.

When the exhaust fans are ready to operate, the surface installation of the low pressure fan at the top of the Quemont No. 2 shaft will also be completed and ready to achieve 445,000 cfm. The air flow in the Quemont No. 2 shaft will then reverse and become downcast to provide fresh air down to level L1190. When this ventilation network is complete, seven development crews will be deployed simultaneously in the mine; three teams via level L1190 and four teams via level L790.

The remaining work to develop the permanent ventilation network for Phase 1 will be completed progressively along with the development and will be ready before production begins.

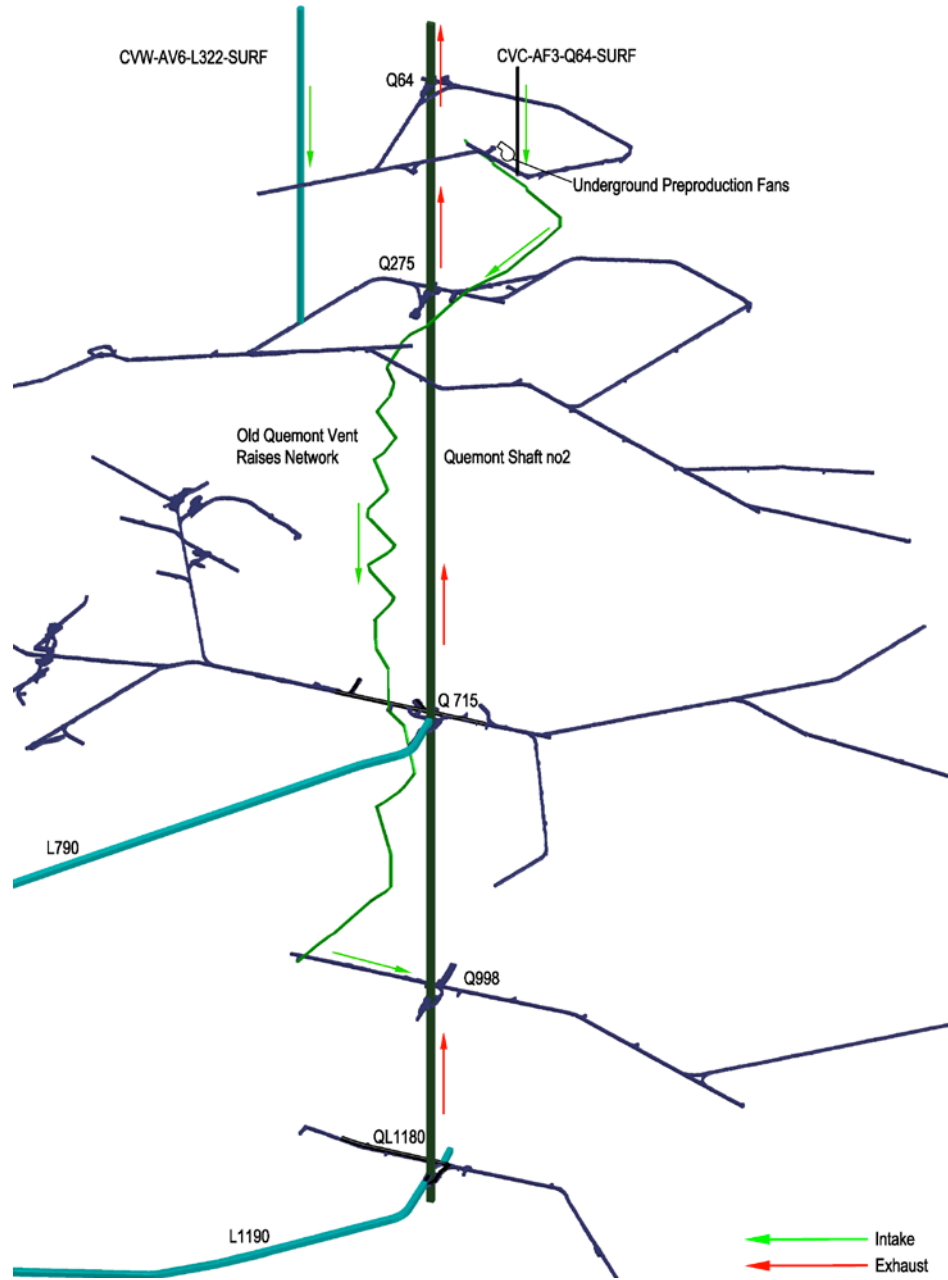

Figure 16-35: Complete preproduction/development ventilation network

### 16.5.5.3 Production Period Air Flow Requirement

The diesel equipment list presented in Table 16-11 was used to calculate the airflow requirements during the production period. The required airflow for each diesel equipment is prescribed per regulation in the province of Québec. The maximum total mine airflow required was calculated with the following method based on the number of diesel equipment operating simultaneously:

- 100% of prescribed airflow for haulage trucks, production LHDs, and development LHDs;
- 75% of prescribed airflow for all service equipment such as scissor lifts, tractors, boom trucks, etc.;
- 50% of prescribed airflow for remaining equipment, mainly stationary equipment such as production drills, jumbos, etc.

The Association Minière du Québec (“AMQ”) proposes three methods to calculate the airflow requirements considering the production, the number of workers underground and airflow velocity. One of these methods estimated the air requirement to support the daily production rate of this operation to be 1,400,000 cfm. However, these methods were not used as they were not developed for highly mechanized or automated mines. The method used and described above to calculate the air requirements is more realistic.

With the calculation method proposed and according to the equipment list, 800,000 cfm are sufficient to support the expected production rate. Considering that VOD will be implemented in the mine, the air flow will be optimized to fulfill the operation’s needs and respect the regulations.

The detailed calculations considered 77 diesel equipment totaling more than 17,000 hp. The estimated airflow requirement based on these equipment is 671,900 cfm. An additional 15% for leakage and contingency was applied and resulted in a total airflow requirement for the Horne 5 Project to be approximately 800,000 cfm.

Table 16-11: Horne 5 Project airflow requirements

MINE EQUIPMENT AIR REQUIREMENT			Based on homologation			total
	Reference Model	Total	HP	Canmet	cfm	cfm
<b>Production Equipment</b>						
Scoop 14 yd	Sandvik LH621	5	475	1,243	14,400	72,000
Truck 50 tonnes	Sandvik TH551	1	760	1,252	49,400	49,400
Production drill	Sandvik DU412I	5	173	1,191	7,900	39,500
Cable drill and bolter	Sandvik DS421	2	148	1,191	9,200	18,400
Explosive truck	MACLEAN BT3	2	173	1,191	7,900	15,800
Scissor lift - Paste backfill piping	MACLEAN SL3	1	173	1,191	7,900	7,900
Tractor u/g - Paste backfill	Kubota M9960 HD	1	99	1,258	4,800	4,800
		<b>17</b>	<b>4,914</b>			<b>164,600</b>
<b>Development Equipment</b>						
Scoop 11 yd	Sandvik LH517	4	400	1,243	12,400	49,600
Truck 50 tonnes	Sandvik TH551	4	760	1,252	49,400	197,600
Jumbo drill	Sandvik DD422I	5	148	1,191	9,200	46,000
Bolting Machine	Sandvik DS411	5	148	1,191	9,200	46,000
Scissor lift	MACLEAN SL3	2	173	1,191	7,900	15,800
Anfo Loader	MACLEAN AC3	2	173	1,191	7,900	15,800
		<b>22</b>	<b>6,812</b>			<b>309,000</b>
<b>Service Equipment</b>						
Scissor lift u/g - Construction	MACLEAN SL3	3	173	1,191	7,900	23,700
Tractor u/g - Mechanical	Kubota M9960 HD	4	99	1,258	4,800	19,200
Tractor u/g - Electrical	Kubota M9960 HD	2	99	1,258	4,800	9,600
Tractor u/g - Technical	Kubota M9960 HD	4	99	1,258	4,800	19,200
Pickup u/g	Toyota Landcruiser	8	127	949	7,300	58,400
Water truck	MACLEAN WS3	1	173	1,191	7,900	7,900
Fuel truck	MACLEAN FT3	2	173	1,191	7,900	15,800
Shotcrete machine (dry)	MACLEAN SS3	2	173	1,191	7,900	15,800
Getman A64 crane	MACLEAN BT3	2	173	1,191	7,900	15,800
Concrete Truck	MACLEAN TM3	2	173	1,191	7,900	15,800
16 Passengers carrier	MACLEAN PC3	3	173	1,191	7,900	23,700
Boom truck U/G	MACLEAN BT3	2	173	1,191	7,900	15,800
Grader		1	173	1,191	7,900	7,900
Lift u/g		1	173	1,191	7,900	7,900
Scoop - service and construction	Kubota 680	1	173	1,191	7,900	7,900
		<b>38</b>	<b>5,466</b>			<b>198,300</b>
<b>Total</b>		<b>77</b>	<b>17,192</b>			<b>671,900</b>
100% truck and LHD + 75% service equipment + 50% stationary equipment						671,900
Leakage and contingency 15%						100,785
<b>Total</b>						<b>772,685</b>

#### 16.5.5.4 Permanent Ventilation System

The permanent ventilation network was designed considering the depth of the orebody to be mined and minimizing the climate impact. In the PEA study, the ventilation network was simplified by providing fresh air via the shaft and the ramps to the ore zone, while the exhaust was evacuated at the east and west extremities of each level. Changes were proposed to provide fresh air directly to the haulage drift on each level on the east side while the exhaust airway remains on the west side. Consequently, fresh air will have the shortest route to reach the ore zone and will not be contaminated by heat from diesel equipment travelling in the ramp.

Several simulations were completed using Ventsim™ to estimate the trend over the life of mine. The last year of full production was the most restrictive and became the so-called “base case”. This base case was used to optimize the ventilation raises and dedicated drifts or ramps in terms of dimensions, quantity and position.

The conclusion of this exercise permits the proposal of a push-pull system. The power requirement is estimated at 4,500 hp for the main ventilation system, which will be located underground at level L322 to limit noise and interaction with the surface in an urban area. According to the estimated airflow and mine static pressures, the fan model for both the fresh air and return air networks will be the same. The proposed design consists of three 96 in axial fans at 1,200 rpm and 1,500 hp with VFD; two fans in parallel in the exhaust air way and one fan in the fresh air way. There is only redundancy for the exhaust fans as there are three fans for the two intakes that allows one fan to be in maintenance and maintain operations.

Two low-pressure and high-volume fans of 200 hp each are installed in the headframe of the Quemont No. 2 shaft and are equipped with noise reduction systems. They push fresh air to the plenum entrance to avoid having to manage a pressure differential in the working areas.

The ventilation network detailed above will supply the airflow requirements. However, for each level, the airflow at the return air raise and at the fresh air raise must be unbalanced. Otherwise no air will flow in the access drift. Also, air velocity in the ramp may be locally too slow. So, with this proposed system, the ventilation technical crew will have to thoroughly understand the network and closely monitor airflow on all levels. For this reason, VOD is planned. The details of the VOD system should be further analyzed in the detailed engineering studies.

VOD will be implemented by installing a live asset tracking system with the operating status on all mobile equipment, flow meters to provide real-time airflow measurements on key locations and automated dampers. These equipment will allow to control airflow on each individual level. VOD is expected to reduce by 40% the propane consumption and by about 63% the electrical consumption associated with the main and auxiliary ventilation.

Figure 16-36 shows the whole ventilation network with the escape ways.

## Fresh Air System

For the permanent ventilation network, fresh air will enter the mine via the planned ventilation raise (CVC-AF5-L322-SURF) and the Quemont No. 2 shaft. The ventilation raise will provide approximately 420,000 cfm ensured by a 1,500 hp fan located at level L322 and another 380,000 cfm will be provided by the shaft for a total of 800,000 cfm.

The main ventilation installation on level L322 will include access doors to the bottom of the raise for maintenance, cleaning or rehabilitation purposes. Monorails and trolleys will be located above the motor and fan for maintenance. Access doors will open in opposite directions for each door, which reduces the hydraulic powerpack dimensions and is safer. Man access will be possible with a main SAS door system beside the mobile fleet door. The whole main ventilation area will have a concrete slab floor, shotcrete on the back and walls and appropriate lighting. An electrical substation will be dedicated to the main intake fan infrastructure. Padlocks could be installed on the motor and damper for maintenance activities.

The CVC-AF5-L322-SURF ventilation raise will be a vertical raisebore with a diameter of 5 m and will be fully supported and equipped with a steel egress manway with a SAS door. This raise connects the surface to level L322, which is the main level for ventilation distribution.

From level L322, fresh air is distributed through a ventilation ramp that connects with a 4 m diameter ventilation raise with an egress manway to level L790 (CVE-AF4-L790-L322). From the CVE-AF4-L790-L322 raise, a dedicated ventilation drift will connect to a 4 m diameter ventilation raise (CVE-AF4-L1190-L790). Below the L1190 transfer drift, fresh air will be split between a series of 3 m diameter ventilation raises located beside the ramp and a series of 4 m diameter ventilation raises on the eastern side of the production levels. The raises between levels L790 and L1910 will not need egress manways since the ramp and the Quemont No. 2 shaft will serve as escape ways. As levels below L1910 are only accessed from the ramp, an egress manway will have to be installed. A total of fifteen new ventilation raises have been planned on the fresh air system network.

The Quemont No. 2 shaft is downcast and provides fresh air to the main access between the Quemont and Horne 5 mines. This network is designed under low-pressure fans and will allow fresh air to convey mainly through ramps and permanent infrastructure, such as crushers, the garage, conveyor drifts, etc.

The historical Quemont ventilation network will be left open to have a parallel path to the shaft. According to the Ventsim™ simulation, it is advantageous to leave it accessible to fresh air from level L115. The surface access to this ventilation raise will be sealed and secured.

For each production level, fresh air will enter either by the fresh air raise on the east side or the main ramp, depending on where the diesel equipment is located and the type of activity. The air will then be distributed to draw points and stopes by secondary fans. Ventilation regulators will be installed on each level just before the fresh air raise to control the air distribution. These regulators will be automated and connect to the surface control room.

### Return Air System

At the western extremity of each production level, the haulage drifts will connect to an exhaust ventilation raise. Automated ventilation regulators will be installed on each level just before the exhaust raise to control the air distribution.

The exhaust network is planned as follows:

- From level L2060 to level L1880: 4 m diameter raisebore (CVW-AV4-L2060-L1880);
- From level L1880 to level L1760: 4 m diameter raisebore (CVW-AV4-L1880-L1760);
- From level L1760 to level L1610: 4 m diameter raisebore (CVW-AV4-L1760-L1610);
- From level L1610 to level L1460: 4 m diameter raisebore (CVW-AV4-L1610-L1460);
- From level L1460 to level L1310: 4 m diameter raisebore (CVW-AV4-L1460-L1310);
- From level L1310 to level L1150: two series of 5 m diameter raisebores (CVW1-AV5-L1310-L1150 and CVW2-AV5-L1310-L1150);
- From level L1150 to level L790: two series of 5 m diameter raisebores (CVW1-AV5-L1150-L790 and CVW2-AV5-L1150-L790);
- From level L790 to level L322: two series of 5 m diameter raisebores (CVW1-AV5-L790-L322 and CVW2-AV5-L790-L322);
- The two return air paths connect on the level L322 main ventilation drift, where exhaust air is brought to the main exhaust ventilation fans. The dimensions of the drift are 5.5 m high by 6 m wide. From the fans, air is pushed through an exhaust vertical raisebore of 6 m diameter from the level L322 to surface (CVW-AV6-L322-SURF).

A total of twelve new ventilation raises are planned on the return air system network.

The exhaust fan redundancy at level L322 will prevent the operation to shutdown. Therefore, the arrangement is planned in a way that maintenance can be done on the first fan while the second one is operating. Ventilation doors are planned to isolate each line to make it safe for operators to do maintenance work. Two separate electrical substations power each line.



---

### Escape Way

The escape ways available throughout the mine are established in the fresh air path as follows:

- From level L322 to surface: in raise CVC-AF5-HL322-SURF and Quemont No. 2 shaft;
- From level L790 to level L322: in raise CVE-AF4-L790-L322 and Quemont No. 2 shaft;
- From level L1910 to level L790: in the ramp and Quemont No. 2 shaft;
- From level L2000 to level L1910: in raise CVE-AF4-L2000-L1910 and ramp;
- From level L2060 to level L2000: in raise CVE-AF4-L2060-L2000 and ramp.

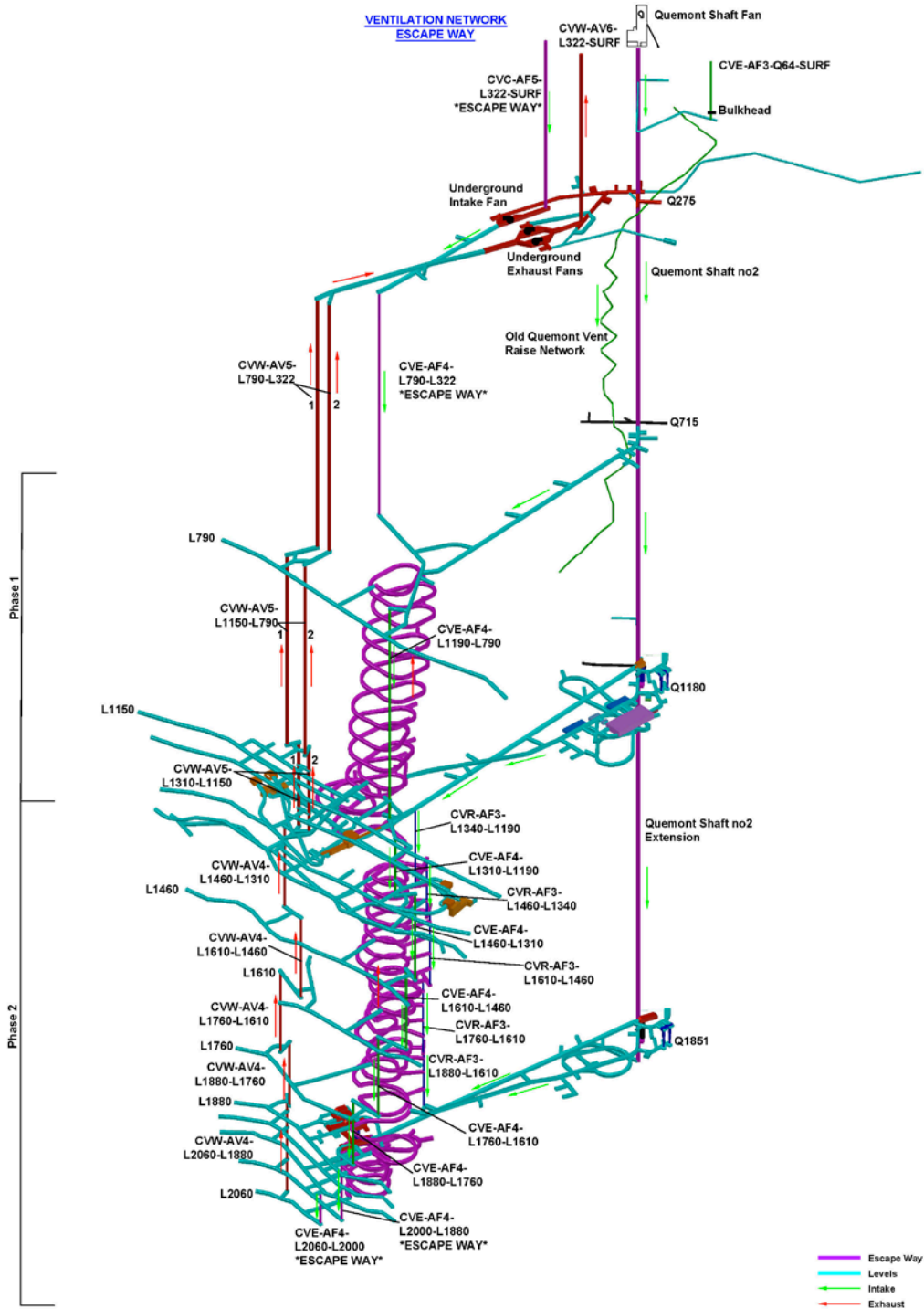

Figure 16-36: Permanent ventilation network with escape ways

#### 16.5.5.5 Ventilation infrastructure

There are also several planned ventilation infrastructure underground, such as regulator doors, SAS doors, ventilation/fire doors and other means of egress in the mine.

Regulator doors will be located on each production level connecting with a ventilation raise. An automatic steel garage door will be regulated to adjust the quantity of air supply at each level. These steel doors could support a pressure over 15 in W.G. The regulator doors are installed on walls made of shotcrete. Safety fences at the bottom of each raise could be unlocked and removed to allow a LHD to remotely clean eventual rock fall.

For the ventilation raises located deeper in the mine, levels located below level L1940, the regulator doors will be installed with a man door on the side to allow egress to the emergency exit.

Dampers fixed on a concrete wall could be installed instead of a regulator door where the airflow needed is smaller.

SAS doors will be composed of two sets of double-doors to allow traffic without air leak. The mobile fleet travelling through these doors will :

- Open the first set of doors;
- Travel into the SAS;
- Close the first set of doors;
- Open the second set of doors;
- Travel to the other side;
- Close the second set of doors.

The SAS doors areas will be built with a concrete slab floor, shotcrete on the back and walls, and have appropriate lighting. Every SAS door will also allow for pedestrians to travel through. The man SAS will be equipped with an electronic indicator to avoid the opening of both doors at same time and thus prevent injury. There will be openings in the walls for auxiliary ventilation and electrical cables. Doors will be protected with bollards, and powered with hydraulic powerpacks and cylinders.

Ventilation/fire doors will be built in the same way as the SAS doors described above, but will only have one double-door for the mobile fleet. Ventilation/fire doors will be located at each shaft station connection and inside the garage area. These doors could be left open or closed, depending on the mine ventilation network.

#### 16.5.5.6 Air Heating System

The surface intake and exhaust raises are positioned in function of wind direction. A burner will be installed on surface at the top of the intake raise (CVC-AF5-L322-SURF) connecting to level L322. The burner will be installed on a concrete slab. Space is planned for the future installation of the peak shaving system to reduce natural gas consumptions.

The only surface installation on top of the exhaust raise planned will be a ducting unit on pilasters above the raise to orient the air in the right direction.

A temporary fan and burner installation is also planned for the development phase of the project on top of the Quemont temporary raise (CVE-AF3-Q64-Surf). This design will allow for the permanent ducting to be installed later in time while development is ongoing, and will reduce the changeover periods.

#### 16.5.5.7 Air Cooling System

BBE Consulting Canada (“BBE”) was retained to determine if cooling would be required for the current deepest portion of the Horne 5 Project, between levels L1880 and L2060. This portion of the mine does not have an orepass system, so ore will be hauled with 50t trucks. BBE’s scope of work included determining heat loads, sizing, recommending a location for the refrigeration plant, the associated capital costs and, finally, a conclusive method statement if refrigeration was deemed necessary.

Cooling requirements are based upon specific Québec legislation with respect to “heat stress” or “contraintes thermiques” as it appears in the French language version of the regulations. Heat stress or “contraintes thermiques” appears within the province’s *Occupational Health and Safety Act*. The regulation uses wet-bulb global temperature (“WBGT”) as the regulatory guide. For the air cooling system study, an inlet wet-bulb (“WB”) temperature of 27.5°C was used as the maximum allowable inlet working temperature. This temperature was determined to be relevant and is used at IAMGOLD’s Westwood mine.

##### Modelling Inputs

The cooling requirements were based on a number of relative inputs. These inputs are listed in Table 16-12 below.

Table 16-12: Modeling inputs

Modeling Input Description	Value
Geothermal Gradient	1.9°C/100 m
Rock Density (Optional if diffusivity set)	2,200 kg/m <sup>3</sup>
Rock Specific Heat	950.0 J/kg°C
Rock Thermal Conductivity	3.00 W/m°C
Rock Thermal Diffusivity	1.435 m <sup>2</sup> /s 10-6
Rock Wetness Fraction	0.25
Surface Atmospheric Lapse Rate	6.4 C/1000 m
Surface Datum Elevation Above Sea Level	300.0 m
Surface Datum of Mine Grid	4,300.4 m
Surface Datum Barometric Pressure	97.8 kPa
Surface Datum Rock Temp	3.5°C
Surface Datum Temperature Dry-bulb	25.0°C
Surface Datum Temperature Wet-bulb	20.0°C
Surface Temperature Adjust	Yes

In addition, the relevant diesel equipment and other heat sources (pumps, conveyors) were placed within the model. The inputs above, along with the diesel equipment, allowed to accurately determine the resultant heat load and therefore determine whether cooling is required or not. The worst-case temperature scenario simulation included two 50 t trucks (Sandvik TH551) travelling in the ramp and one LHD (Sandvik LH621) on the lowest production level of the mine.

### Heat Sources

Heat loads in a mine are attributable to several sources. In deep Canadian mines, where the geothermal gradients (“GT”) and virgin rock temperatures (“VRT”) are not extreme, the principal sources of heat are autocompression and the diesel equipment. Figure 16-37 shows the relevant heat source contributions for the Horne 5 underground mine.

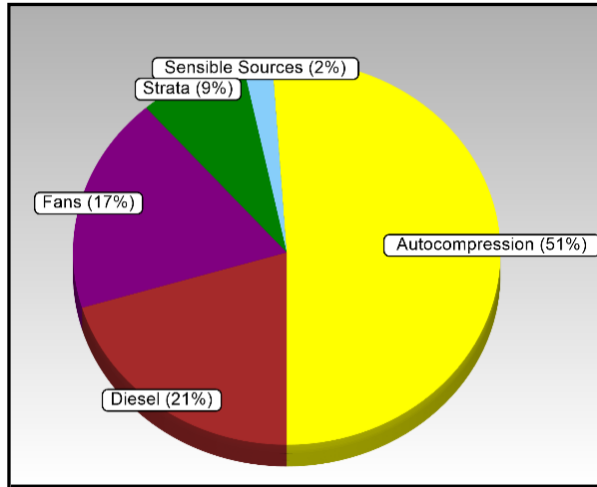

Figure 16-37: Heat sources for the Horne 5 underground mine

### Considerations and Conclusion

Considering the worst case scenario, the air cooling simulation showed that cooling would be required below level L1880 only. The production rate below this level will be 1,850 tpd, which is approximately 12% of the mine's total production and mainly at the end of the mine life plan. Given the production rate, the short summers and depth of the Horne 5 Project, air cooling will not be required all year long. In fact, when using the available weather data for this area, it is likely that the conditions that require refrigeration (above 23°C DB and 17°C WB) may occur less than 30 days per year (and not continuously).

Despite these facts, a refrigeration plant, if it was to be implemented, would need to be sized for the worst case scenario and to be available to operate for approximately 120 days per year. Such systems are very expensive and in this case, not necessary.

BBE concluded that other alternatives could be put in place to reduce the requirement for cooling during these hotter periods, including, but not limited to:

1. Mining sufficient tonnage from other zones;
2. Stockpiling the lower ore in areas above the hotter zones;
3. Blasting during the day shifts and production mucking during the night shifts;
4. Avoid production in the lower part of the mine during hot summer days; etc.

Considering these restrictions, no cooling system will be installed in the bottom part of the mine as the production is marginal and less than 3,000 tpd.

## 16.6 Mine Design

The proposed mine design for the Horne 5 Project is divided into two phases consisting of 42 levels:

- One level solely for ventilation purposes (connection between Horne 5 deposit and Quemont No. 2 shaft) – level L322;
- Sixteen (16) levels for Phase 1 production – from level L710 to level L1310;
- Twenty-five (25) levels for Phase 2 production – from level L1340 to level L2060.

To avoid any problems with historical Horne mine openings, all new levels are developed between the historical Horne mine levels. The old openings below level L710 will all be backfilled using paste backfill. The only time historical openings will be intersected is in the middle of stopes (between levels). This design is to mitigate risks associated with water and slurry inflow.

### 16.6.1 Quemont No. 2 Shaft

The existing rectangular 6.5 m by 4.4 m Quemont No. 2 shaft will be rehabilitated and deepened to be used as the production shaft for the Horne 5 Project. Figure 16-38 and Figure 16-39 show the original and rehabilitated shaft configurations. The options to install a headframe and the hoisting facility were very limited because of the location of the Horne 5 Deposit directly under the existing Horne smelter. The Industrial Park of Rouyn-Noranda showed the best possibility to avoid interfering with the Smelter's operations. After research and trade-offs, the site of the Old Quemont Mine showed the best option with the presence of the Quemont No. 2 Shaft that had a compatible size for the production anticipated. Moreover, the depth of the existing shaft (1,200 m) corresponds to approximately half of the potentially mineable resources of the Horne 5 deposit. All these considerations led to the decision to reuse the Quemont minesite and refurbish the existing shaft for the Horne 5 Project.

The existing shaft is equipped with wood sets assumed to be installed every 2,440 mm (8 ft). The shaft was configured with compartments for two skips, one cage, one counterweight, a man way and a compartment for services. In order to re-use the shaft, all existing wooden structures will be dismantled and hoisted to the surface while all existing stations will be rehabilitated and secured. A concrete liner of 150 mm will be poured into the shaft while ground support and shotcrete will be installed in stations. Prior to pouring the concrete liner, ground support will be installed along the shaft as described in Section 16.2.6.

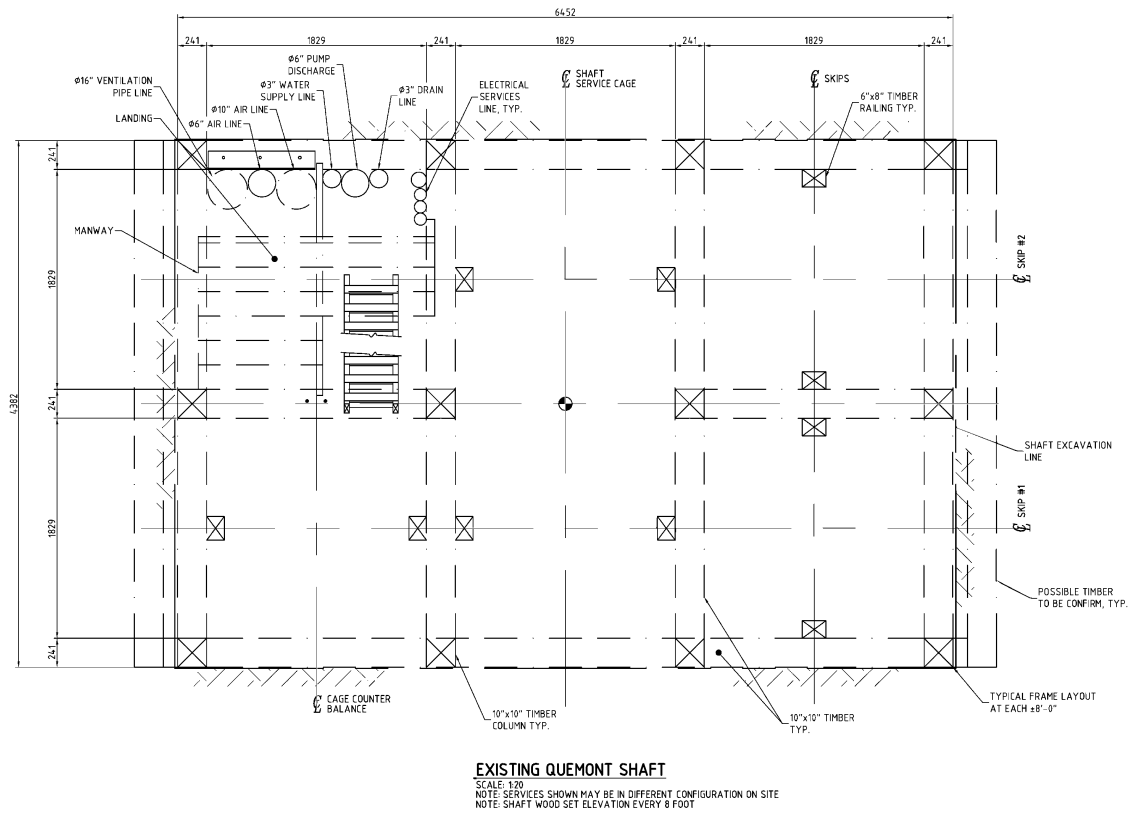

**Figure 16-38: Quemont No. 2 existing shaft**

The rehabilitated shaft will be equipped with steel sets every 6.0 m to support two 43.0 t skips, one double-deck service cage, one double-deck auxiliary cage, one counterweight and services. The service cage will have a capacity of 15 000 kg or 50 men/deck and the auxiliary cage will have a capacity of 5 men/deck. The steel sets are designed to allow the high-speed operation (up to 18 m/s) of the 43.0 t skips on cantilever members.





In Phase 1, the working platforms are designed to perform the wood stripping, the ground support, the station rehabilitation and excavation, the concrete pouring of the shaft lining, the shaft steel and station installation, mine dewatering, and shaft bottom excavation and mucking. Shaft services, such as electrical cables and piping installation, is included in the rehabilitation cycle. During the shaft rehabilitation, waste material will be hoisted to the surface to be sorted and recycled whenever possible.

The shaft rehabilitation will be performed simultaneously with the mine dewatering using pumps suspended under the Galloway. Mine dewatering work will always be one station or approximately 30 m ahead of the shaft rehabilitation work to ensure workers safety. Barricades will be installed at each existing historical station to protect the workers from water influx and seal the shaft from old workings for ventilation reasons.

During the development of Phase 2, the shaft will need to be deepened to reach level Q1910, which will be the location of the loading station and the bottom of the shaft for Phase 2. The deepening of the shaft for Phase 2 will be performed using winches installed in a temporary hoist room below a rock pillar between levels Q1240 and Q1260 left in place to maintain production in Phase 1 while excavating the shaft for Phase 2. In order to complete the shaft deepening, a pilot hole will be drilled and reamed to a larger diameter from level Q1260 to level Q1910. The shaft will be slashed in the bore hole as the Galloway progresses. The ground support, the shaft lining and the steel installation will be performed from the Galloway.

## 16.6.2 Shaft Access

The original shaft configuration has a total of 24 existing stations.

The new shaft design requires the use of five of the 24 existing stations:

- Level Q64 at elevation 4,188 m, connection with level L115;
- Level Q275 at elevation 3,977 m, connection with level L322;
- Level Q550 at elevation 3,703 m, no connection with Horne 5 deposit, pumping station;
- Level Q715 at elevation 3,537 m, connection with level L790;
- Level Q1180 at elevation 3,073 m, loading station connection with main level L1190.

The station at level Q64 will be rehabilitated to access the new ventilation raise and to connect to the Quemont mine's old ventilation raise network.

The stations at levels Q275, Q715 and Q1180 will be equipped with a lip and will be used as temporary loading stations for mine lateral development during the preproduction period. The station at level Q1180 will be the permanent loading station for production in Phase 1.

The Phase 1 shaft bottom is located at elevation 3,013 m, level Q1240.

---

The following five new stations will be constructed when deepening the Quemont No. 2 shaft:

- Level Q1240 at elevation 3,013 m, shaft bottom, for Phase 1 prior to shaft re-sinking (this level becomes a station in Phase 2 only);
- Level Q1260 at elevation 2,993 m, sheave deck for deepening the shaft (Phase 2);
- Level Q1290 at elevation, 2,963 m, shaft sinking;
- Level Q1491 at elevation 2,761 m, pumping station;
- Level Q1851 at elevation 2,401 m, loading station connection with main level L1880;

The shaft bottom for Phase 1 at elevation 3,013 m, level Q1240, will be used as a station in Phase 2 while the new stations at levels Q1260 and Q1290 are required for shaft sinking in Phase 2. The station at level Q1491 will be used for mine dewatering in Phase 2. The permanent loading station in Phase 2 is located at level Q1851.

The Phase 2 shaft bottom is located at elevation 2,341 m, level Q1911.

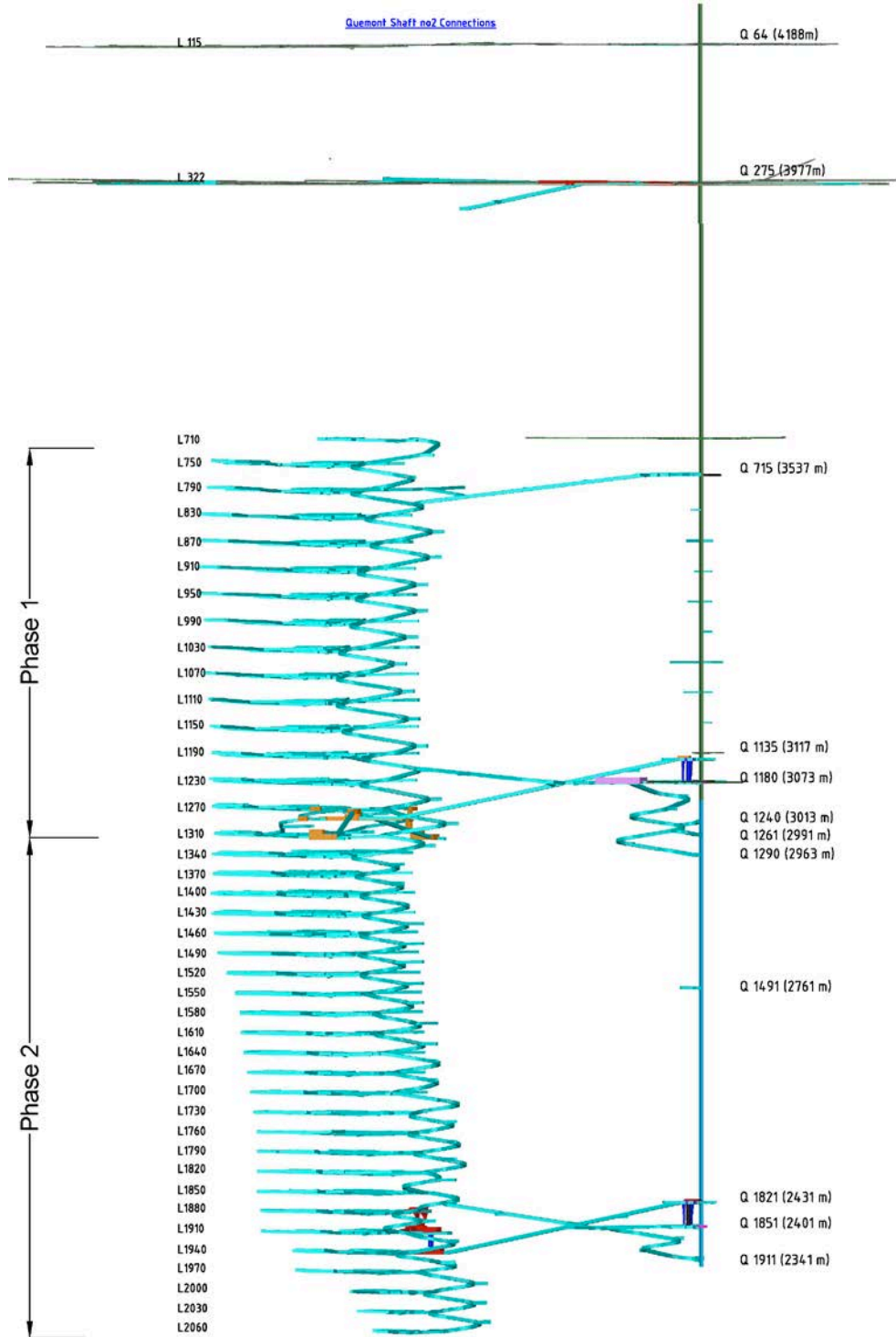

Figure 16-40: Horne 5 underground mine and Quemont No. 2 shaft levels

### 16.6.3 Ore Hoisting System

The ore hoisting system will enable to hoist material (ore and waste) to surface in the skips. Two different hoisting systems will be used for hoisting material :

- The temporary loading stations, only used during the preproduction period;
- The permanent loading stations, used as soon as the production hoist is functional.

For waste and ore handling during the preproduction period, three temporary loading stations will be set up in the Quemont No. 2 shaft (Figure 16-41) at levels Q275, Q715 and Q1180. A remuck located near the temporary loading station on each of these levels is planned. These remucks will have the capacity to contain at least the daily production volume of waste from the development teams. LHDs will be used to dump on a grizzly and then onto a transition chute (lip). The lip will be used to direct the material to a 15 t measuring box feeding the skips with an arc gate. The skip capacity is set to 15 t to allow the service hoist to carry the material to surface before the completion of the shaft rehabilitation, and the complete installation of the production hoist and the Q1180 permanent loading station.

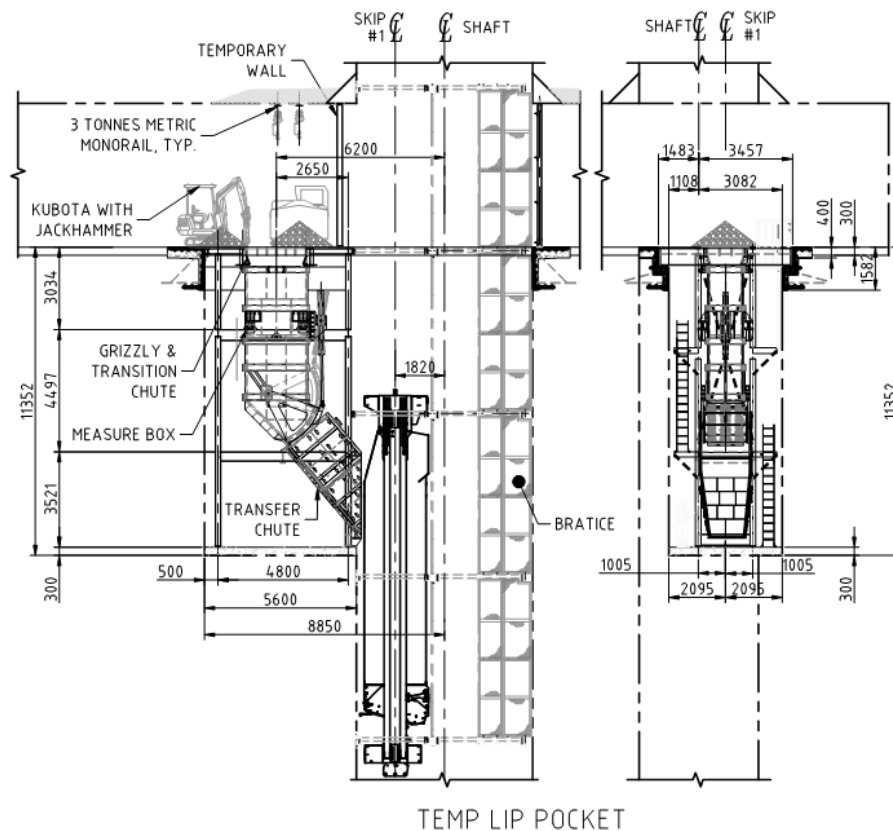

Figure 16-41: Typical temporary loading station

The permanent loading stations (Figure 16-42) at levels Q1180 and Q1851 will be equipped with a transition silo to allow more operational flexibility. The silo will discharge on an apron feeder feeding a conveyor to the loading pocket. The loading pockets will be equipped with a transfer car directing material in the two 43 t measuring boxes feeding the production skips through an arc gate. They will each have a dedicated electrical room located on the same level. The electrical rooms will be fed by a 600 V feeder from the level substation. Also, a 600 V motor control centre (“MCC”), a 600 V panelboard, frequency drives and PLCs will be installed in each electrical room.

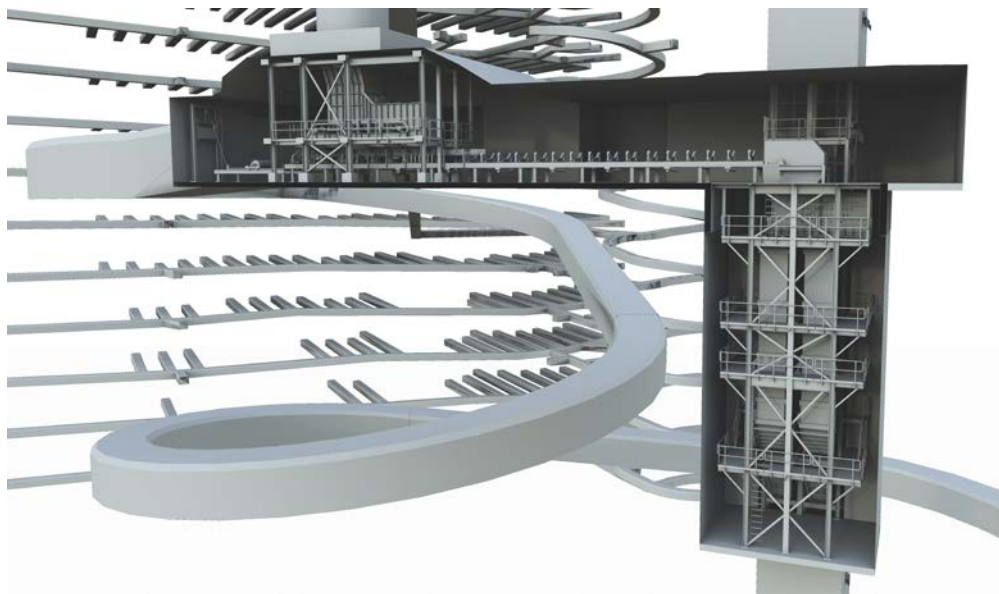

Figure 16-42: Loading station at levels Q1180 and Q1851

#### 16.6.4 Main Infrastructure

All required underground infrastructure are designed per the applicable regulations. The location of the refuge stations depend on the distance from the next refuge or workplace (*Mining Act*).

Table 16-13 presents the list of the underground infrastructure planned for both Phase 1 and Phase 2 of production and Figure 16-43 presents the location of all main infrastructure throughout the mine.



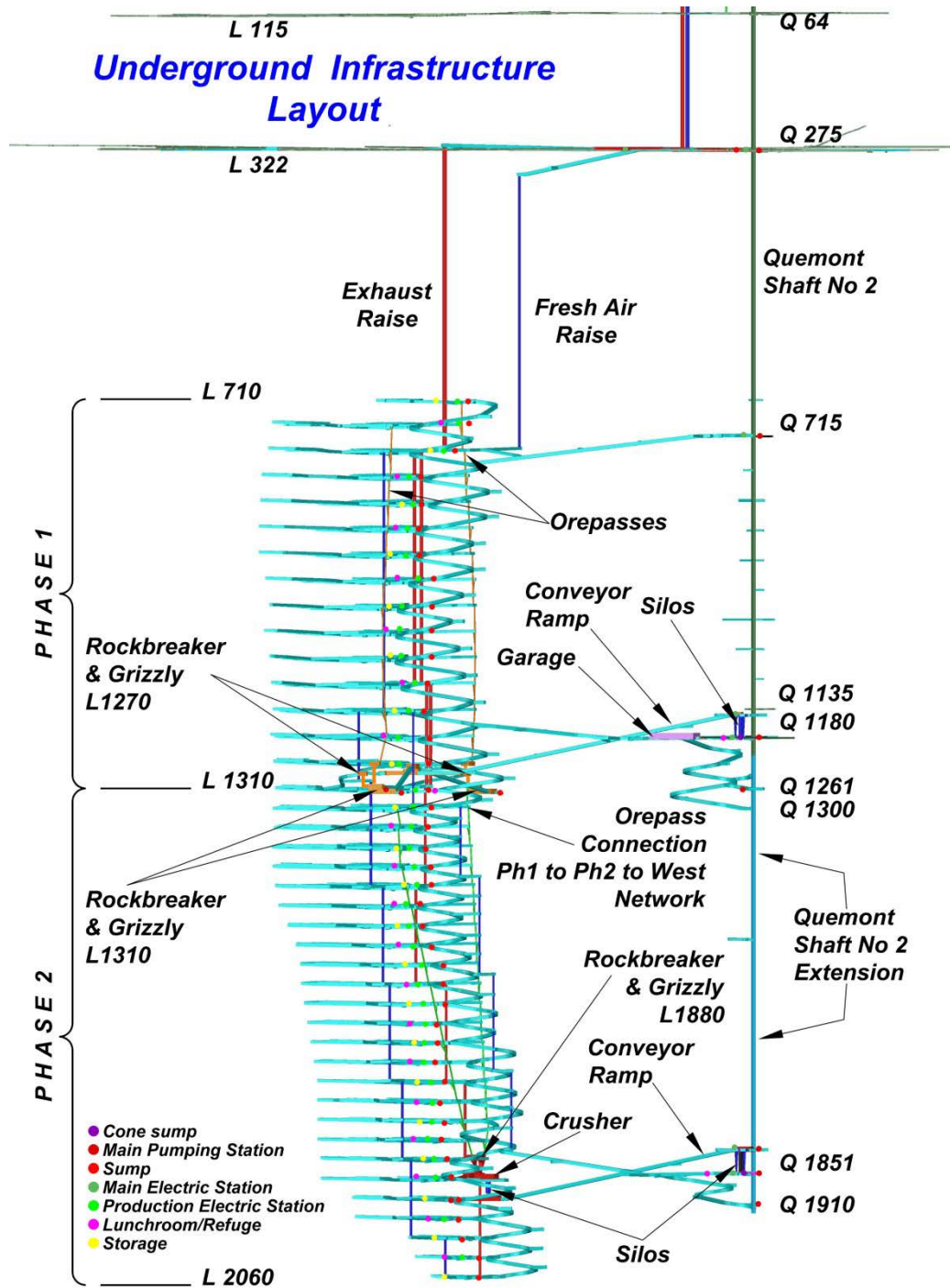

Figure 16-43: Main infrastructure location in the mine

### 16.6.4.1 Production Level Infrastructure

Most of the production levels will have the same underground infrastructure. In general, each level will have the following:

- Four automation control doors to limit access to personel while teleoperating (some levels will have only two);
- Two or three ventilation doors;
- Two ore passes, one on the east side and one on the west side;
- One water sump;
- One backfill bay;
- One electric production substation;
- Either one storage area or one refuge/lunch room, with toilets.

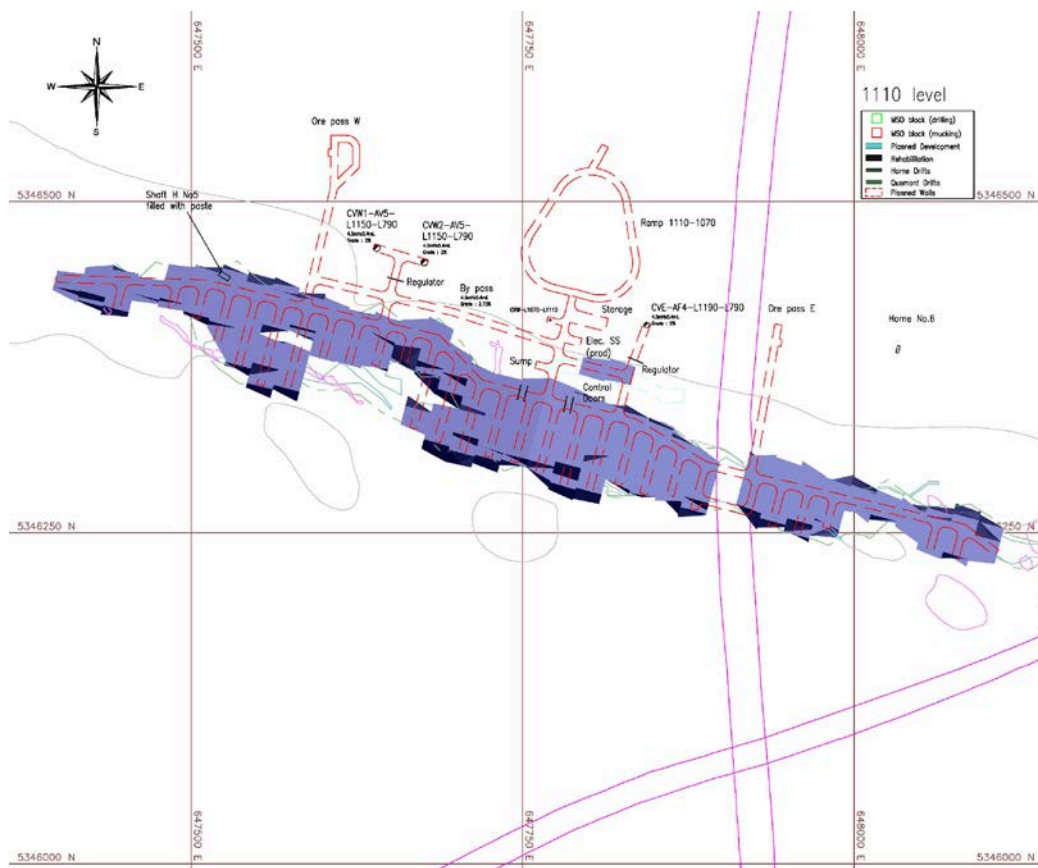

Figure 16-44: Typical production level – general arrangement with storage and level in ore



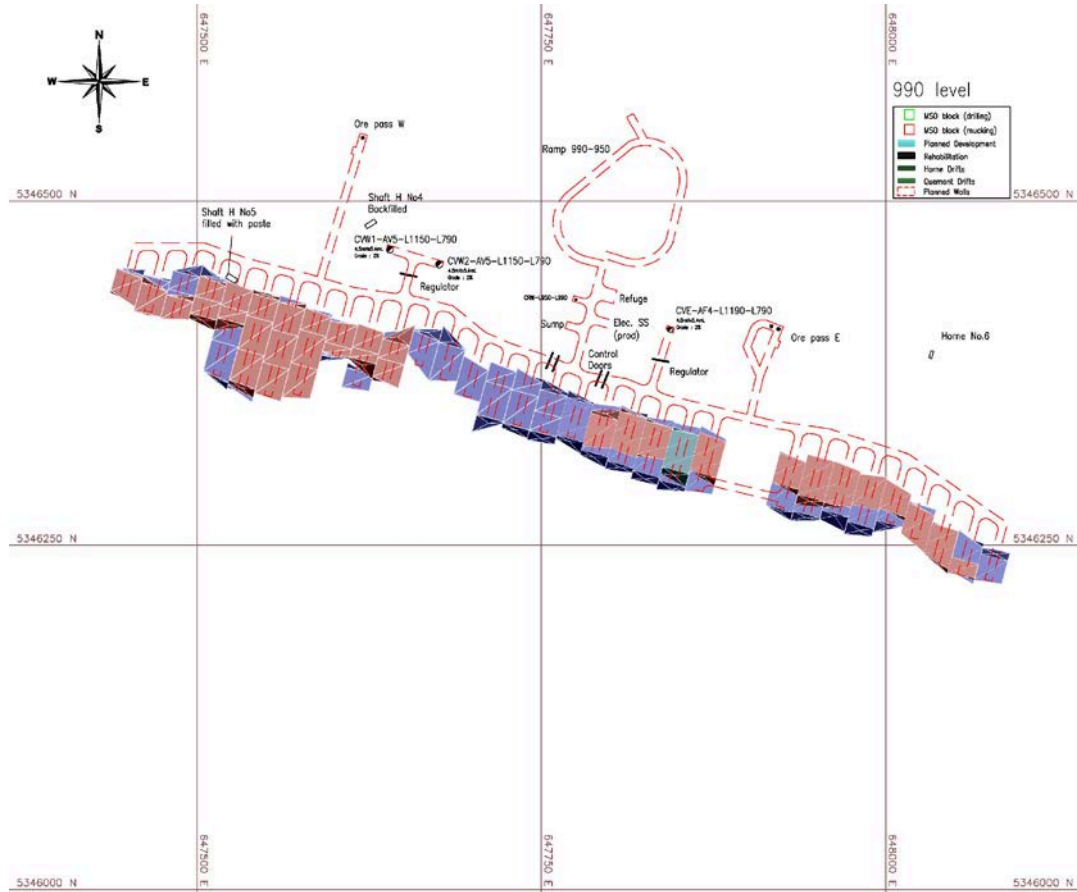

Figure 16-45: Typical production level – general arrangement with refuge and level in waste

#### 16.6.4.2 Main Levels Infrastructure

##### Phase 1

In Phase 1, the main levels will be L1190 (connecting with Q1180), L1270 (connecting with Q1135) and L1310. These levels will have major services infrastructure and ore handling installations.

Level L1190 will have the garage (mechanic shop) and the following related infrastructure (Figure 16-46):

- Main powder magazine and cap magazine;
- Warehouse (general and oversize pieces);
- Tire storage;
- Weld shop;

- Electric shop;
- Wash bay and sump;
- Oil and lube storage and bay;
- Fuel bay;
- Offices;
- Refuge/lunch room.

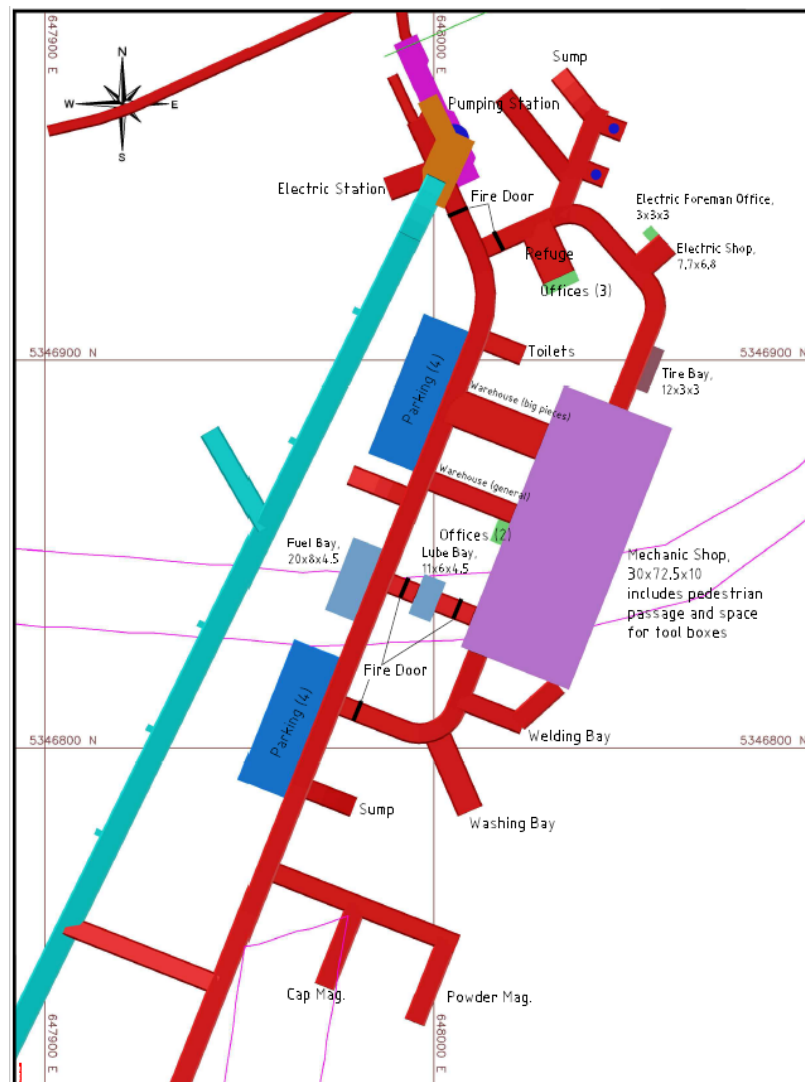

Figure 16-46: Garage and service infrastructure general arrangement – level L1190

Level L1270 will have two rockbreakers and two grizzlies, one set for each orepass network, on the east and west sides. This level will also have a transfer area to the main conveyor for the crushed ore coming from the crushers located on level L1310. The main conveyor will carry the material to the silo on top of the loading area on level Q1135.

Level L1310 will have two crushers and two rockbreakers, one set for each ore pass network, each centralized on the eastern and western portion of the ore deposit. The rockbreakers will allow the LHDs to dump on the top of the crushers on level L1310 instead of having to travel up the ramp to level L1270.

## Phase 2

In Phase 2, the main levels will be L1880 (connecting with Q1851), L1940 (connecting with Q1821) and L1910. These levels will have major services infrastructure and ore handling installations.

Level L1880 will have a refuge on the Quemont side, a fuelling station and a main powder and cap magazines. There will be two rockbreakers on this level, one for each network, on the east and west sides.

Level L1910 will have one crusher and a dumping station to dump directly on top of the crusher. The crusher will then fill a silo to feed a conveyor on level L1940.

Level L1940 will have the main conveyor that carries the material to the top of a silo at level Q1821. The material will descend the silo by gravity to the loading area located on level Q1851.

Table 16-13: Underground main infrastructure listed by level

Horne #5 Levels	Total	PHASE 1																	
		L115	L322	L710	L750	L790	L830	L870	L910	L950	L990	L1030	L1070	L1110	L1150	L1190	L1230	L1270	L1310
Remuck Bay (Access)	10					4										1		3	2
Control door (automation)	60			2	2	4	4	4	4	4	4	4	4	4	4	4	4	4	4
Storage bay	9	1	1			1				1				1			1		
Refuge	11	1		1	1	1			1				1	1	1			1	
Toilets	11	1		1	1	1			1				1	1	1			1	
Remuck	2	2																	
Remuck Bay (Ramp)	24	2		1	5			1	1	1	1	1	1	1	5	1	1	1	
Slurry Drill Bay	1	1																	
Parking	3					3													
Main Cap Mag	3	1			1										1				
Main Powder Mag	3	1			1										1				
Exhaust Air Vent unit	1	1																	
Fresh Air Vent Unit	1	1																	
Fire door (Shaft)	3	1			1										1				
Regulator Door	30			1	1	2	2	2	2	2	2	2	2	2	2	2	2	2	
Cone plug (ore pass)	31			1	2	2	2	2	2	2	2	2	2	2	2	2	2	2	
2.4 m Ore pass	27			1	2	2	2	2	2	2	2	2	2	2	2	2	2	2	
Arc Gate (ore pass)	14					1	1	1	1	1	1	1	1	1	1	1	2		
Press door (ore pass)	14					1	1	1	1	1	1	1	1	1	1	1	2		
Rock breaker	2																2		
1310 Rock breaker	2																	2	
Crusher station	2																	2	
Apron Feeder	2																	2	
Conveyor 19%	2																	2	
Ramp Conveyor	1																1		
Ore bin	2														1				
Loading station	1														1				
Truck Loading Bay	-																		
Sump	22	1	1	1	1	1	1	1	1	1	1	1	1	3	1	2	3		
Slurry pumping station	3															2	1		
Top cone sump	1															1			
Cone sump	1														1				
Cone sump bottom	1														1				
Sludge pump	1															1			
Clear water pumping station	3	1				1									1				
Backfill bay	16			1	1	1	1	1	1	1	1	1	1	1	1	1	1	1	
Horne Drain Holes Station	3	1				1									1				
Oil and lub storage	1														1				
Fire door (Fuel)	4														4				
Fuel bay	1														1				
Garage	1														1				
Wash Bay	1														1				
Garage Parking	2														2				
Tire Storage	1														1				
Warehouse (general)	1														1				
Warehouse (big pieces)	1														1				
Weld shop	1														1				
Electric shop	1														1				
Office	6														6				
Main electric stations	4	1	1			1									1				
Production electric stations	18	1	1	1	1	1	1	1	1	1	1	1	1	1	1	1	1	2	

Total	PHASE 2																									
	L1340	L1370	L1400	L1430	L1460	L1490	L1520	L1550	L1580	L1610	L1640	L1670	L1700	L1730	L1760	L1790	L1820	L1850	L1880	L1910	L1940	L1970	L2000	L2030	L2060	
4																										
88	4	4	4	4	4	4	4	4	4	4	4	4	4	4	4	4	4	4	4	4	2	2	2	2	2	2
13	1		1		1		1		1		1		1		1		1		1		1		1		1	
13		1		1		1		1		1		1		1		1		1		1		1		1		
13		1		1		1		1		1		1		1		1		1		1		1		1		
-																										
10																			4	1	1	1	1	1	1	
-																										
-																										
1																				1						
1																				1						
-																										
-																										
1																					1					
69	3	3	3	3	3	3	3	3	3	3	3	3	3	3	3	3	3	3	3	2	2	2	2	2	2	
36	2	2	2	2	2	2	2	2	2	2	2	2	2	2	2	2	2	2	2	2	2	2	2	2	2	
37	1	2	2	2	2	2	2	2	2	2	2	2	2	2	2	2	2	2	2	2	2	2	2	2	2	
20	1	1	1	1	1	1	1	1	1	1	1	1	1	1	1	1	1	1	1	2						
20	1	1	1	1	1	1	1	1	1	1	1	1	1	1	1	1	1	1	1	2						
2																										
2																				2						
-																										
1																					1					
1																						1				
-																										
1																						1				
2																						1				
1																						1				
5																							1	1	1	
28	1	1	1	1	1	1	1	1	1	1	1	1	1	1	1	1	1	1	3	1	2	1	1	1	1	
4																						2		1	1	
1																						1				
1																						1				
1																						1				
2																							1			
24	1	1	1	1	1	1	1	1	1	1	1	1	1	1	1	1	1	1	1	1	1	1	1	1	1	
-																										
-																										
-																										
1																							1			
-																										
-																										
-																										
-																										
-																										
1																										
25	1	1	1	1	1	1	1	1	1	1	1	1	1	1	1	1	1	1	1	1	1	1	1	1	1	

## 16.6.5 Permanent Ore Handling System

### 16.6.5.1 Ore Pass Networks

The Phase 1 and Phase 2 material handling systems will consist of 2.4 m diameter double ore pass networks. Each production level will be split into an east and west zone from the central main level access drift connected to the ramp. Each zone will be served by an independent ore pass network. Ore passes will be developed every two levels with a raisebore machine. Levels between the top and bottom of the ore pass will connect with a finger. This network design will result in an average distance of 221 m between a stope and the nearest ore pass, to maximize the efficiency of the scooptram productivity. The ore pass networks will be able to manage either waste or mineralized material.

Each ore pass will service two levels. The upper level will have a cone plug and a press door. One access will be provided to the cone plug in order to dump material into the ore pass. Likewise, there will be a second access behind the ore pass to muck material coming from the upper levels. The press door will control the material by either retaining it or sending it through to the next ore pass. This configuration will allow mineralized and waste material to be sorted, depending on whether a given level is in production or being developed. Since all the waste material will be returned as backfill into the empty stopes, this configuration will provide easy access to waste material for secondary stopes.

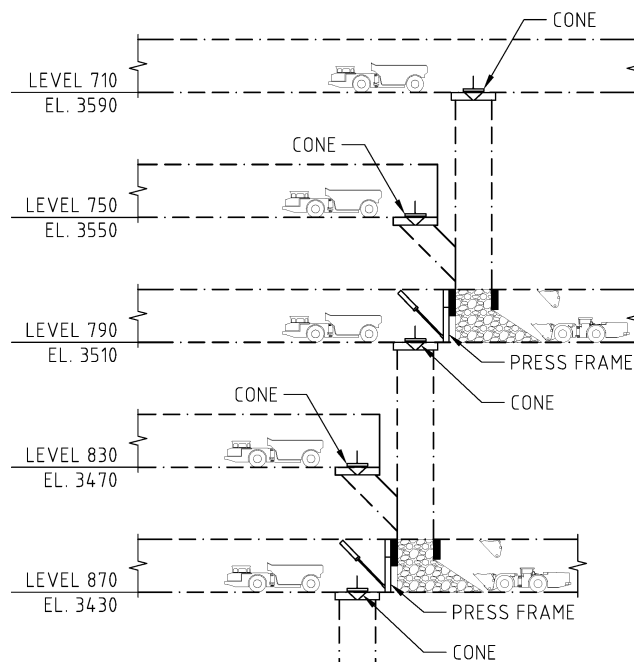

Figure 16-47: Ore pass configuration

The lower level will have a cone plug and a finger to reach the ore pass. Each lower level will have one cone plug dump, one cone plug and a press door dump, except for the levels L710 and L750. See Table 16-14 for the detail by level of the ore pass networks configuration.

Table 16-14: Ore pass networks configuration

Level	Ore pass network configuration	
	West (101)	East (201)
L710	CP	-
L750	CP	CP
L790	CP-PD	CP
L830	CP	CP-PD
L870	CP-PD	CP
L910	CP	CP-PD
L950	CP-PD	CP
L990	CP	CP-PD
L1130	CP-PD	CP
L1170	CP	CP-PD
L1210	CP-PD	CP
L1240	CP	CP-PD
L1270	PD-CC-GR-RB-TR-MC	PD-CC-GR-RB
L1310	PD-CC-GR-RB-CR-CRC	PD-CC-GR-RB-CR-CRC
L1340	CP-PD	CP
L1370	CP	CP-PD
L1400	CP-PD	CP
L1430	CP	CP-PD
L1460	CP-PD	CP
L1490	CP	CP-PD
L1520	CP-PD	CP
L1550	CP	CP-PD
L1580	CP-PD	CP
L1610	CP	CP-PD
L1640	CP-PD	CP
L1670	CP	CP-PD
L1700	CP-PD	CP
L1730	CP	CP-PD
L1760	CP-PD	CP
L1790	CP	CP-PD
L1820	CP-PD	CP
L1850	CP	CP-PD
L1880	PD-CC-GR-RB	PD-CC-GR-RB
L1910	CR-DS	-
L1940	MC	-

CC-GR-RB = Control chute and Grizzly and RockBreaker

CP = Cone plug

CR = Crusher

CRC = Crusher conveyor

CR-DS = Crusher with dumping station

PD = Press door

MC = Main Conveyor

TR = Transfer

This configuration was designed for automation purposes and to provide flexibility to the operation. With this design, the east or west networks can be closed to personnel and managed by automated LHDs. The double dump access on each level will allow for production and development on the same level without interaction between them, or for production on both sides of the level. The ore handling system will benefit from the short average haulage distance, making it possible to avoid using trucks for hauling as much as possible.

There will be a connection between Phase 1 and Phase 2 on the west ore pass network. Under the rock breaker station, a 2.4 m raise will connect with the ore pass on level L1340. When the ore handling system will be completed on level L1940, the muck from Phase 1 will be stopped at the L1270 rock breaker station and then continue down to be loaded onto the conveyor on L1940.

The grizzlies and rock breaker stations will be fed by ore passes and by trucks. The grizzlies will allow material less than 406 mm to move down to the crushing stations. The rock breakers will break the oversized rocks.

Underneath the grizzlies and rock breaker stations, the ore passes will connect on levels L1310 and L1910 for Phase 1 and Phase 2 respectively and feed the crushing stations for each phase.

There will be two loading stations planned on the Quemont No. 2 shaft, one on level Q1197 for Phase 1 and another one on level Q1867 for Phase 2.

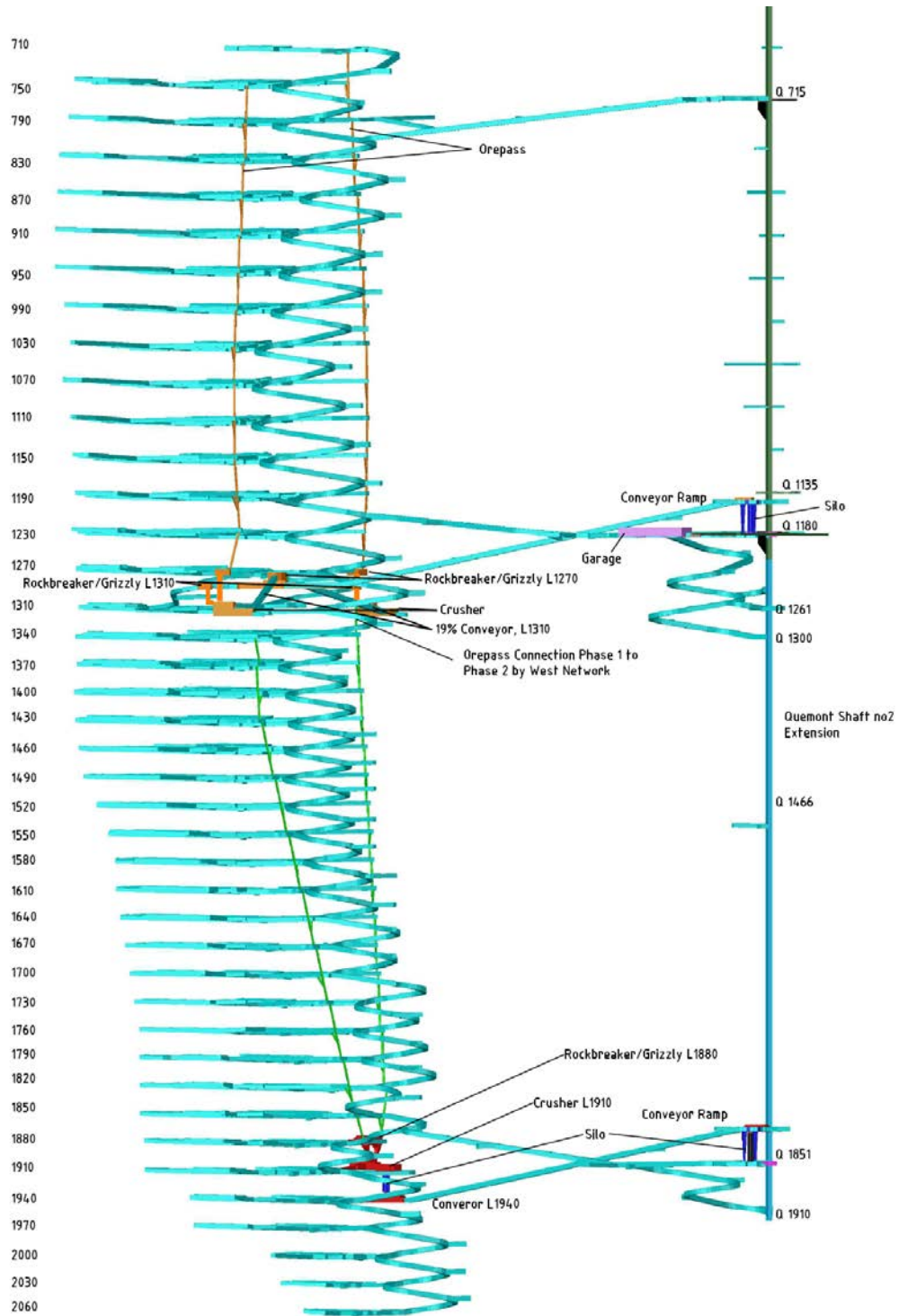

Figure 16-48: Elevation view of the material handling network



### 16.6.5.2 Crushing Stations – Phase 1

The rockbreaker, crushing and conveyor facilities are designed to meet and exceed the production requirements. On level L1310, the underground crushing system is separated in two networks, namely west (101) and east (201), which will be operated simultaneously. Both networks will contain the same mechanical equipment, concrete, steel and electrical equipment, but the west network will be built before the east network. These networks will work in parallel and dump into the same transfer box, which has a capacity of 607 t.

The crushing stations will be fed by the ore coming from both the level L1270 rockbreaker stations and the level L1310 rockbreaker stations. The east and west rockbreaker stations located on level L1270 have control chutes. However, the east and west rockbreaker stations located on level L1310 do not have control chutes and trucks will dump directly onto the grizzly.

From the silos feeding the crushers, the material smaller than 150 mm will go through the grizzly feeders, while material greater than 150 mm will be fed to the jaw crusher. Each crushing station is designed to operate 12 h/d and crush 9,600 tpd, for a total of 19,200 tpd. The objective is to hoist material smaller than 150 mm at the shaft.

Once the material will be crushed, it will be transferred onto a sacrificial conveyor, which will feed the crusher conveyor of each network. The crusher conveyors will have a 54 in wide belt, be 210 m long and have a slope of 19%. The crusher conveyors from each network will carry the material to a common central transfer box into the transfer room. The ore will then be carried by the main conveyor to the top of the loading station silo located on level Q1135. The main conveyor will be 563 m long with a slope of 19%.

The underground crushing system has been separated into six areas presented in Table 16-15. Each system, west and east, will have its own feed stations.

Table 16-15: Underground crushing system – Phase 1

Area no.	Level	Ore handling area description	Ore pass network
127-242-101	L1270	Control Chute	West
127-242-201	L1270	Control Chute	East
127-243-101	L1270	Grizzly & Rock Breaker	West
127-243-201	L1270	Grizzly & Rock Breaker	East
131-243-101	L1310	Grizzly & Rock Breaker	West
131-243-201	L1310	Grizzly & Rock Breaker	East
131-244-101	L1310	Crusher Room	West
131-244-201	L1310	Crusher Room	East
131-246-101	L1310	Jaw Crusher Conveyor	West
131-246-201	L1310	Jaw Crusher Conveyor	East
119-245-001	L1270	Long Conveyor	One per level
127-247-001	L1270	Transfer Room	One per level

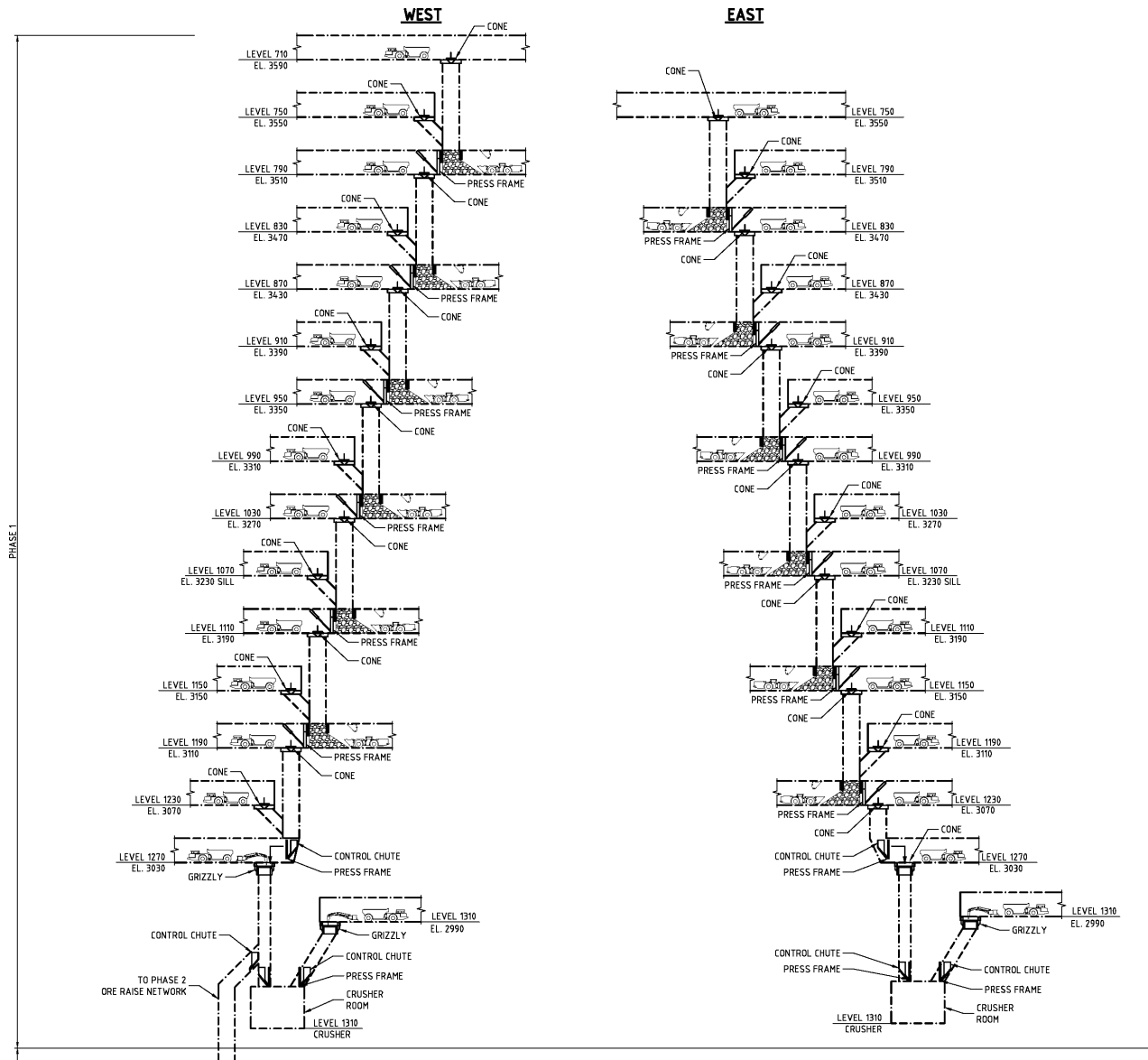

Figure 16-49: Ore handling ore passes diagram – Phase 1

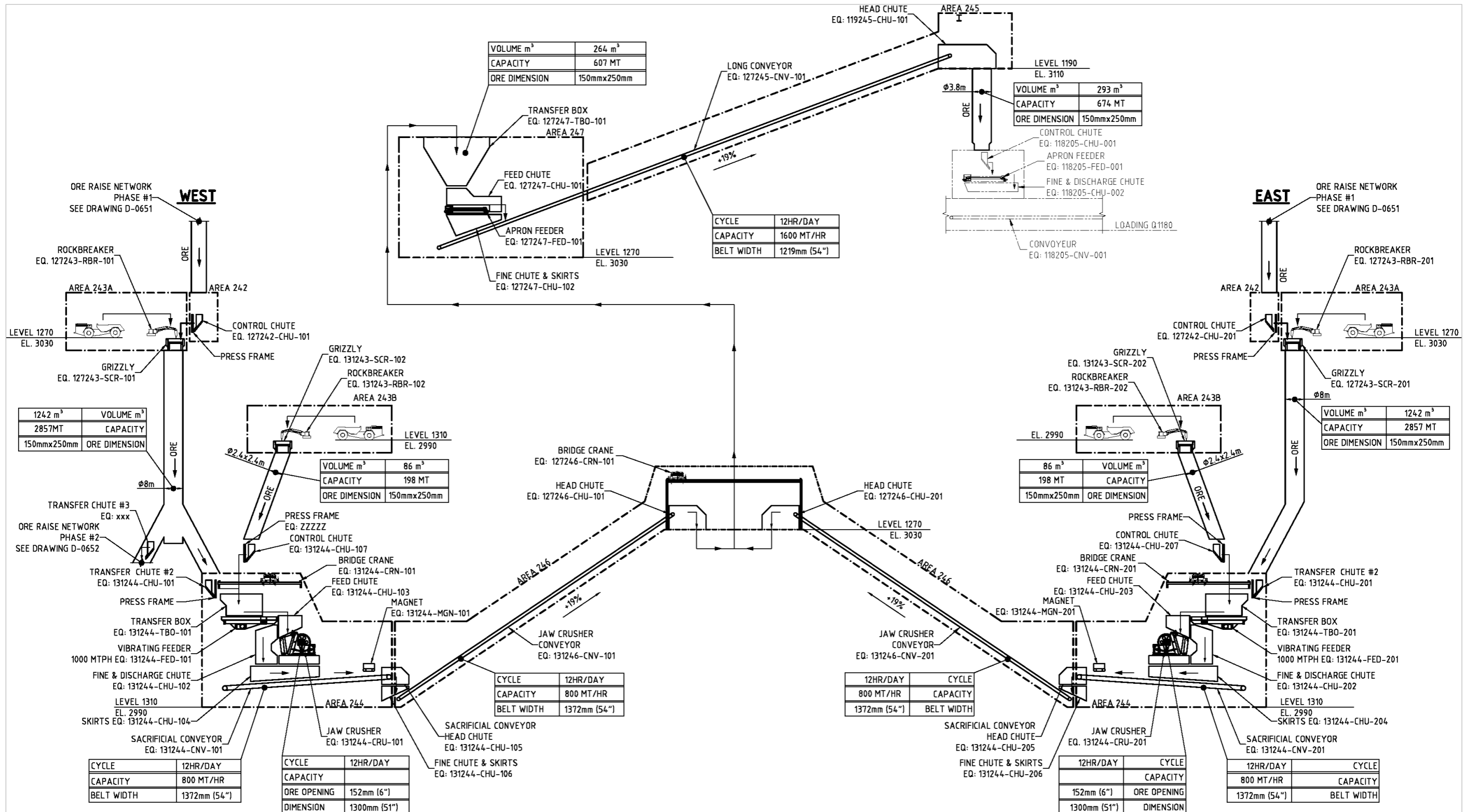

Figure 16-50: Ore crushing and handling diagram – Phase 1

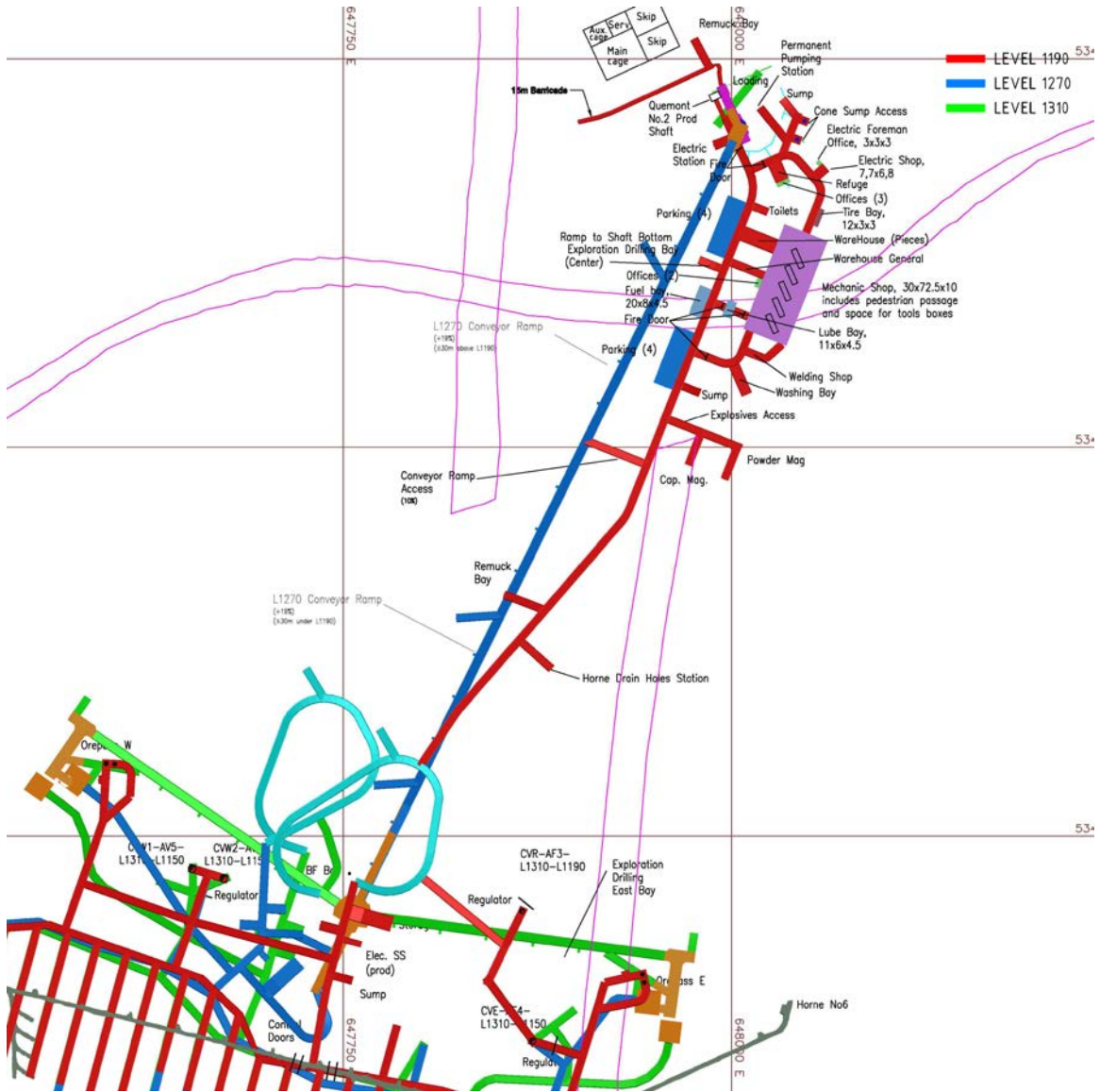

Figure 16-51: Material handling infrastructure – Plan view Phase 1

### 16.6.5.3 Crushing station - Phase 2

The Phase 2 underground crushing system will merge the two ore handling networks (west and east) into a single crushing system with the same capacity (see Figure 16-52).

When Phase 2 will be in operation, the west crushing station on level L1270 will be by-passed. The material will be directed into the transfer chute instead of the crusher. The Phase 2 ore pass network will feed both the east and west rockbreaker stations located on level L1880 with ore coming from all the levels above.

On level L1910, the crushing station will be fed by the ore coming from either the silo below the rockbreaker stations or from the direct dump station located on level L1910. The direct dump station to the crusher will be used by the mobile equipment coming from levels L1910 and below. Since levels L1940 to L2060 do not connect with the shaft, material will be hauled by trucks up to level L1910. A charging bay will be excavated on each level so LHDs can load the trucks. The direct dumping station to the crusher will be equipped with a vibrating grizzly scalper. If an oversized rock will placed on this vibrating grizzly, the oversized rock will be scalped on the floor. The rock could then be removed by a LHD and crushed later or brought to the rockbreaker station on level L1880. This setup will avoid the use of a portable rock breaker and reduce congestion when feeding the system with LHDs.

Ore coming from the ore passes will be dumped on a two-way 60 in belt conveyor with an apron feeder. The material will move towards a jaw crusher, where a self-cleaning magnet will remove any metal. Material smaller than 150 mm will pass between the bars of the grizzly feeder. Material greater than 150 mm will be fed to the jaw crusher. The crushing station is designed to operate 12 h/d and crush 16,350 tpd. The objective is to hoist material smaller than 150 mm at the shaft.

Between levels L1910 and L1940, there will be a silo with a capacity of 1,716 t under the crushing station. Another apron feeder will feed a sacrificial conveyor with a 54 in belt located on level L1940. The sacrificial conveyor will feed a second 54 in wide belt conveyor. The length of the second conveyor is approximately 500 m with a 17% grade. This conveyor will travel the material to the top of a second ore silo. From the second ore silo, a third apron feeder will be used to feed the level Q1851 loading station, which will ultimately feed the skips at the Quemont No. 2 shaft.

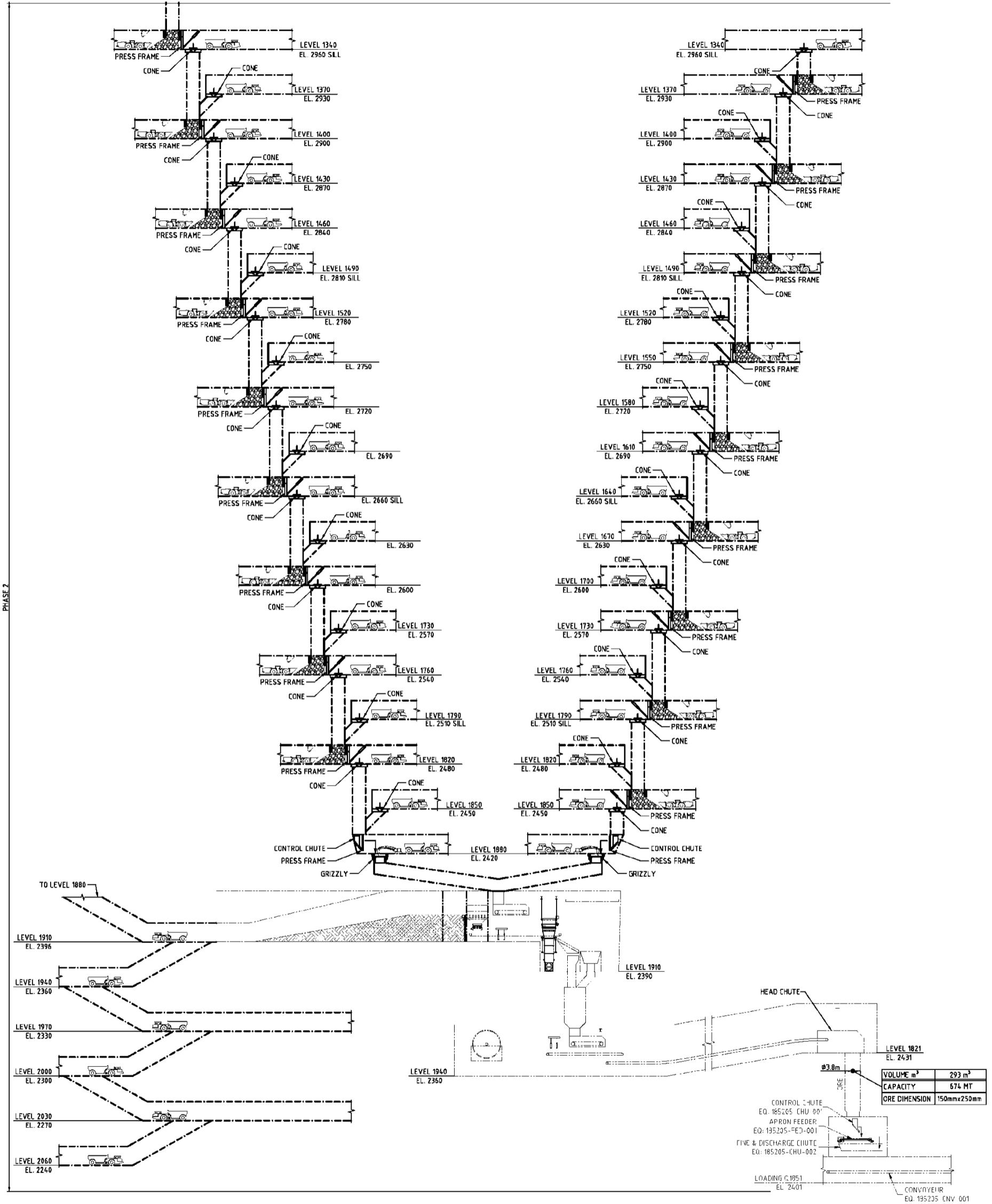

Figure 16-52: Underground infrastructure diagram – Phase 2 ore handling



### 16.6.6 Development Schedule

Contractors will be used for the preproduction phase consisting of the required work for dewatering, shaft rehabilitation, drift rehabilitation and initial development. Falco's equipment and mine crews will progressively replace those of the contractors only when production period is started. The raisebore work, however, will continue to be done by the contractors for the whole life of the mine.

The following design criteria were used to develop the mine plan schedule:

- Jumbo multi-face (>3) drift development: 10 m/d;
- Jumbo with maximum two-face drift development: 6 m/d;
- Jumbo with single-face drift development: 4 m/d;
- Rehabilitation of old excavations: 10 m/d;
- Raise boring of a 6 m diameter raise including support: 4 m/d;
- Raise boring of a 4 m diameter raise including support (shotcrete): 4 m/d;
- Raise boring of a 2.4 m diameter raise including support (shotcrete): 6 m/d.

The typical dimensions of horizontal development elements are provided in Table 16-16.

Table 16-16: Excavation dimensions

Excavation	Width (m)	Height (m)
Internal ramp	5.4	5.5
Level access	5.4	4.5
Footwall drift	5.4	4.5
Draw point	5.4	4.5

Size of the ventilations drifts may vary depending on the air flow requirement.

Table 16-17 shows the number of metres of development per year.

Table 16-18 shows a the main mine development milestones on a Gantt chart for the life of the mine.

Table 16-17: Development quantities per year in metre

Period		Preproduction			Production														Total		
Year		2019 (m)	2020 (m)	2021 (m)	2021 (m)	2022 (m)	2023 (m)	2024 (m)	2025 (m)	2026 (m)	2027 (m)	2028 (m)	2029 (m)	2030 (m)	2031 (m)	2032 (m)	2033 (m)	2034 (m)	2035 (m)	(m)	
Phase 1	Deferred Horizontal Development	5,248	12,596	3,661	2,792	2,277	2,191	711	251	291	292	85	45	-	-	-	-	-	-	30,440	
	Current Horizontal Development	24	2,756	-	8,193	3,677	3,811	3,369	3,050	2,431	1,237	-	150	150	150	187	150	150	300	29,785	
	Total Horizontal Development	5,272	15,352	3,661	10,985	5,954	6,002	4,080	3,301	2,722	1,529	85	195	150	150	187	150	150	300	60,225	
	Deferred Vertical Development	3,311	2,285	622	200	360	120	-	-	-	-	-	-	-	-	-	-	-	-	-	6,898
	Total Development	8,583	17,637	4,283	11,185	6,314	6,122	4,080	3,301	2,722	1,529	85	195	150	150	187	150	150	300	67,123	
	Stope Rehabilitation	-	-	-	-	500	500	700	800	800	800	800	600	525	349	-	-	-	-	-	5,574
Phase 2	Deferred Horizontal Development	-	-	-	-	2,779	3,467	3,598	5,073	4,372	2,073	3,274	575	687	681	1,207	1,240	1,184	3,632	33,843	
	Current Horizontal Development	-	-	-	-	-	240	420	420	1,620	1,440	3,410	5,423	7,274	6,432	5,049	4,924	3,644	4,440	44,736	
	Total Horizontal Development	-	-	-	-	2,779	3,707	4,018	5,493	5,992	3,513	6,684	5,998	7,961	7,114	6,256	6,165	4,828	8,072	78,580	
	Deferred Vertical Development	-	-	-	-	4,637	14,454	31,453	12,248	10,201	9,693	839	6,611	8,181	-	-	-	-	-	-	98,317
	Total Development	-	-	-	-	7,417	18,161	35,470	17,741	16,193	13,206	7,523	12,610	16,142	7,114	6,256	6,165	4,828	8,072	176,897	
	Stope Rehabilitation	-	-	-	-	-	-	-	-	-	-	-	-	-	-	-	-	-	-	-	-
Total	Deferred Horizontal Development	5,248	12,596	3,661	2,792	5,056	5,658	4,309	5,324	4,663	2,365	3,359	620	687	681	1,207	1,240	1,184	3,632	64,283	
	Current Horizontal Development	24	2,756	-	8,193	3,677	4,051	3,789	3,470	4,051	2,677	3,410	5,573	7,424	6,582	5,236	5,074	3,794	4,740	74,521	
	Total Horizontal Development	5,272	15,352	3,661	10,985	8,734	9,709	8,098	8,794	8,714	5,042	6,769	6,193	8,111	7,264	6,443	6,315	4,978	8,372	138,805	
	Deferred Vertical Development	3,311	2,285	622	200	4,997	14,574	31,453	12,248	10,201	9,693	839	6,611	8,181	-	-	-	-	-	105,215	
	Total Development	8,583	17,637	4,283	11,185	13,731	24,283	39,550	21,042	18,915	14,735	7,608	12,805	16,292	7,264	6,443	6,315	4,978	8,372	244,020	
	Stope Rehabilitation	-	-	-	-	500	500	700	800	800	800	800	600	525	349	-	-	-	-	-	5,574



Table 16-18: Mine development schedule – Main milestones

	Period	Preproduction				Production														
		2018	2019	2020	2021	2021	2022	2023	2024	2025	2026	2027	2028	2029	2030	2031	2032	2033	2034	2035
Shaft Accesses	L790		█																	
	L1190			█																
	L1880								█	█	█	█								
Main Infrastructure	L322 Ventilation System & Other		█																	
	L1190 Maintenance Work Areas			█	█															
	L1270 Material Handling System				█															
	L1310 Material Handling System			█																
	L1880 Material Handling System									█	█									
	L1940 Material Handling System									█										
Production Levels	Phase 1		█	█	█	█	█	█	█	█	█	█								
	Phase 2						█	█	█	█	█	█	█	█	█	█	█	█	█	█

## 16.7 Mining Method

The main mining methods selected for Horne 5 Project are transverse long hole stoping with primary and secondary sequence. This selection is based on the geometry of the mineralized zones, their vertical dip and the competency of the rockmass to allow high production rate. Some sectors are also mined using longitudinal long hole retreat and pillarless sequences.

### 16.7.1 Transverse Long Hole Mining Method Description

This mining method involves accessing stopes using two transverse draw points: one above the stope for drilling and loading of bulk explosives, and one below for extracting blasted material. The empty stope is then backfilled to allow mining of the adjacent stopes. Stopes will be mined according to a primary/secondary sequence, thus increasing flexibility and productivity while ensuring rock stability. For levels L1310 to L1030, the thickness of the ore zones (approximately 100 m) permits the haulage drifts to be excavated inside the ore zone thus reducing waste and initial capital cost, and accelerate the mining schedule. So, a longitudinal retreat mining sequence will be used for the last stope of each draw point on these levels.

Stope dimensions will vary with depth to reduce the potential dilution and the risk of seismicity. Maximum stope dimensions are presented in the Table 16-19.

Table 16-19: Maximum stope dimensions

Depth	Type of Stope	Height (m)	Width (m)	Minimum Thickness (m)	Maximum Thickness (m)
Surface to 1,310 m	Primary / Secondary	40	20	5.4	25
1,310 m to 1,880 m	Primary	30	20	5.4	16
	Secondary	30	16	5.4	24
1,880 m to 2,060 m	Pillar less	30	16	5.4	16

The transverse long hole mining method allows for a high degree of mechanization and automation and is amenable to tele-operation. Production technicians will be able to operate LHDs from a control room at surface, resulting in higher equipment usage rates, better productivity and less maintenance. This approach adds four extra hours of effective production per day by allowing to extract ore in between shifts and at lunch time. It is also estimated that the use of automation will reduce both the number of pieces of equipment and the number of personnel required to reach the production target.

The time required to mine a given stope, from the time it is drilled to the time its backfill has cured, is expected to be 65 days (Table 16-20, Figure 16-53 and Figure 16-53). However, the effective cycle time is 50 days as it will be possible to drill an adjacent stope while the backfill is curing. To achieve the production target averaging 15,500 tpd over the LOM, 16 stopes must be active (drilling, extraction or backfilling) at any given time. A total of 9 stopes averaging 50,000 t each are projected to be mined every month in Phase 1, while 18 stopes averaging 26,600 t will be needed in Phase 2. It could be possible to shorten the cycle time as preliminary results show that the necessary backfill strength could be achieved within 21 days.

**Table 16-20: Mining cycle times**

Stage	Activity	Time (days)
Drilling	Stope rehabilitation	2
	Slot raise-30 in (V30)	3
	Drilling	9
Extraction	Blasting	4
	Mucking	10
Backfilling	Barricade	2
	Plug (with curing time)	4
	Residual	3
	Curing	28
<b>Total</b>		<b>65</b>



- Blasting practices will leave 1.0 m of mineralization on both the hanging wall and the footwall so that the 0.5 m of dilution will be in ore with the same NSR value of the mineralized zone;
- Failure along backfilled stopes is expected to be 0.5 m with an NSR value of 0 \$/t.

It was assumed that the ore left behind represents an average of 10% of the total mineralization. The hanging wall and footwall dilution will allow half (5%) of this envelope to be recovered for an overall mining recovery of 95%. The overall dilution amounts to 2.3%.

### 16.7.3 Drilling and Blasting Pattern

The mineralized zones will be divided into mining horizons ranging from four to nine stopes high. Each horizon will in turn be subdivided into pyramids, providing many available workplaces to achieve the production target (see Figure 16-63).

#### 16.7.3.1 Drill Hole Diameters and Fragmentation

It was proven in a drilling and blasting analysis (BBA) that the optimum drilling diameter is 165 mm (or 6.5 in). This diameter will generate the required fragmentation without exceeding the vibration levels targets fixed to minimize impact on surface infrastructure. The particle size distribution curve, Figure 16-54, shows an advantage in terms of overall fragmentation with the 165 mm option, which is most likely due to a better charge distribution.

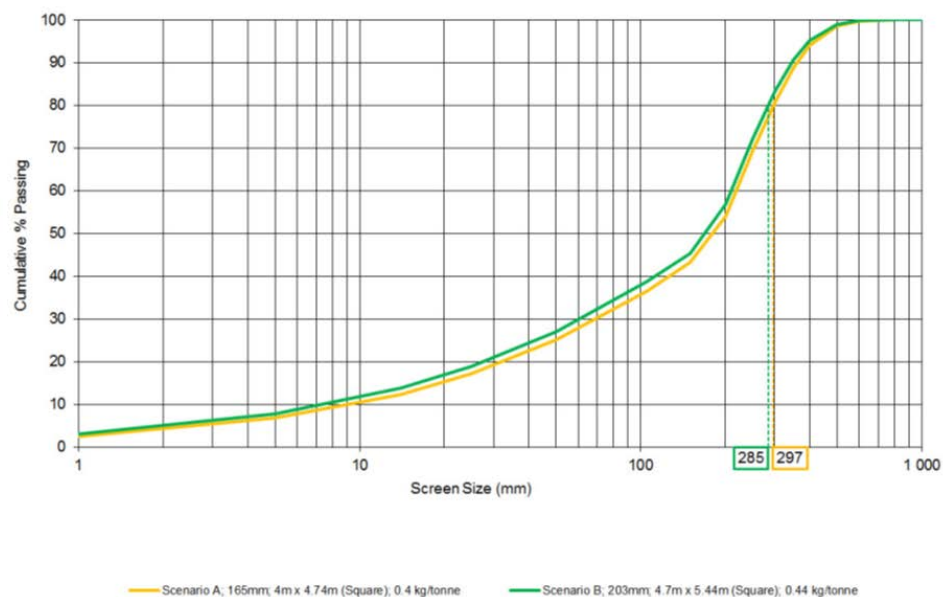

Figure 16-54: Particle size curve comparison between 165 mm and 203 mm blast hole diameters (BBA, 2017)

### 16.7.3.2 Vibration Prediction

The USBM standard represents the basis of several laws and regulations linked to blasting activities in Québec. Among these regulations, Directive 019 sets forth the limitations of vibrations and air over-pressures generated by blasting activities. Table 16-21 displays the maximum allowable peak particle velocities (“PPV”) as a function of the frequencies for underground mines located less than 1 km from a monitoring point.

Table 16-21: Allowable vibration limits per frequency range, according to Directive 019

Vibration frequency (Hz)	Maximum permissible velocity (mm/s)
Frequency $\leq$ 15	12.7
15 < Frequency $\leq$ 20	19.0
20 < Frequency $\leq$ 25	23.0
Frequency > 25	25.0

In accordance with USBM criteria, the maximum permissible PPV for a frequency less than 15 Hz is 12.7 mm/sec. It is important to state that Falco has committed to maintaining vibration levels at the surface below 5 mm/sec. This is more than 50% lower than the regulatory limit and translates to an additional safety factor when estimating the maximum charge per delay. Lastly, Directive 019 also obliges the mining operator to setup and maintain a vibration and air overpressure monitoring network. This is accomplished by installing and monitoring seismographs at strategic permanent and temporary locations. The incoming blast data will be used to refine the vibration prediction model to optimize the blasting design specifications.

Falco is committed to maintaining a vibration limit of  $\leq$ 5 mm/sec during blasting operations to reduce to the maximum the impact on the town of Rouyn-Noranda and different stakeholders. The Horne smelter represents the nearest protected structure and is located above the ore body at a minimum distance of approximately 650 m. To better understand the impact and range of blast-induced vibrations at this location, a vibration prediction analysis was conducted for the 165 mm diameter blast hole design.

**Table 16-22: Maximum charge length per hole (165 mm diameter) depending on depth analysis for blast-induced vibration under 5 mm/s at surface (BBA, 2017)**

Depth (m)	PVS (mm/s)	WEXPLOSIVE (Kg)	Charge length per hole (m)	Maximum charge length per hole (m)
600	4.94	240	8.98	8
650	4.98	285	10.66	10
700	4.43	285	10.66	10
750	4.67	350	13.09	13
800	4.69	400	14.97	14
850	4.25	400	14.97	14
900	4.64	500	18.71	18
950	4.26	500	18.71	18
1,000	4.84	650	24.32	24
1,100	4.66	750	28.06	28
1,200	4.48	850	31.80	31
1,300	4.31	950	35.54	35

The calculations involve the following assumptions:

- The column charge is continuous and fully coupled;
- Bulk emulsion has a density of 1.25 g/cc;
- No deck.

The data from the blast-induced vibration analysis, presented in Table 16-22, were plotted as a graph. A linear extrapolation was then deducted from the data and the result is presented in Figure 16-55.

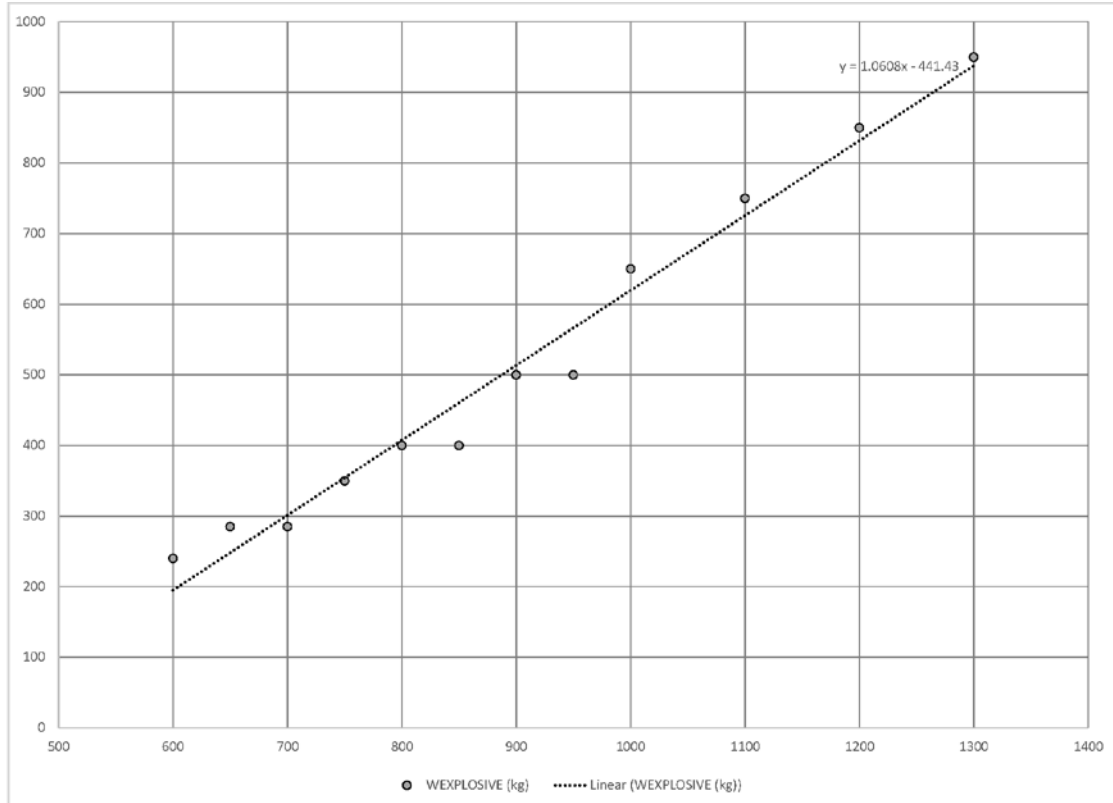

Figure 16-55: Linear extrapolation for weight of explosive vs depth from surface

From that linear extrapolation, it was then possible to calculate the maximum charge weight for every level in the mine.

### 16.7.3.3 Drill and Blast Patterns

Stope dimensions depend on many factors:

- Stope width depends on depth, and whether it is a primary or secondary stope. Width ranges from 16 m to 20 m;
- Stope length depends on the width of the orebody, and whether it is a primary or secondary stope. Length ranges from 12 m to 25 m;
- Stope height is constant at 40 m for Phase 1 and 30 m for Phase 2. There will be upper stopes on level L710 with a height of 22 m and on level L750 with a height of 25 m.



Considering the varying stope dimensions and the varying maximum allowable weight of explosives (dependent on depth), it was inconceivable to design a single drill and blast pattern. By analyzing the stopes, it was required to detail seven drill and blast patterns for all the types of stopes in the Horne 5 Project.

To ensure optimal blasting dynamics, stopes will be blasted in either one or two stages. The first stage will widen the opening surrounding the bottom of the slot raise and create the necessary void space for the subsequent blasting stage. The volume of this opening blast will be limited to the available empty volume found within the underlying access drift and the V30 slot raise. A minimum 20% void ratio (for swelling) will be maintained for each stage of blasting. Once the blasted material from the initial cut will be mucked out of the stope, the second blast will be the last blast.

Blast holes will be drilled in a fan pattern from a drift located above the stope. The selected drill pattern comprises 165 mm (6.5 in) diameter holes with 4.5 m spacing, 5.0 m burden and a primary opening using a V30. The density of the explosive emulsion is 1.25 g/cm<sup>3</sup>.

The number of rings on the drilling pattern will depend on the length of the stope. Figure 16-56 presents a typical drilling pattern in plan view.

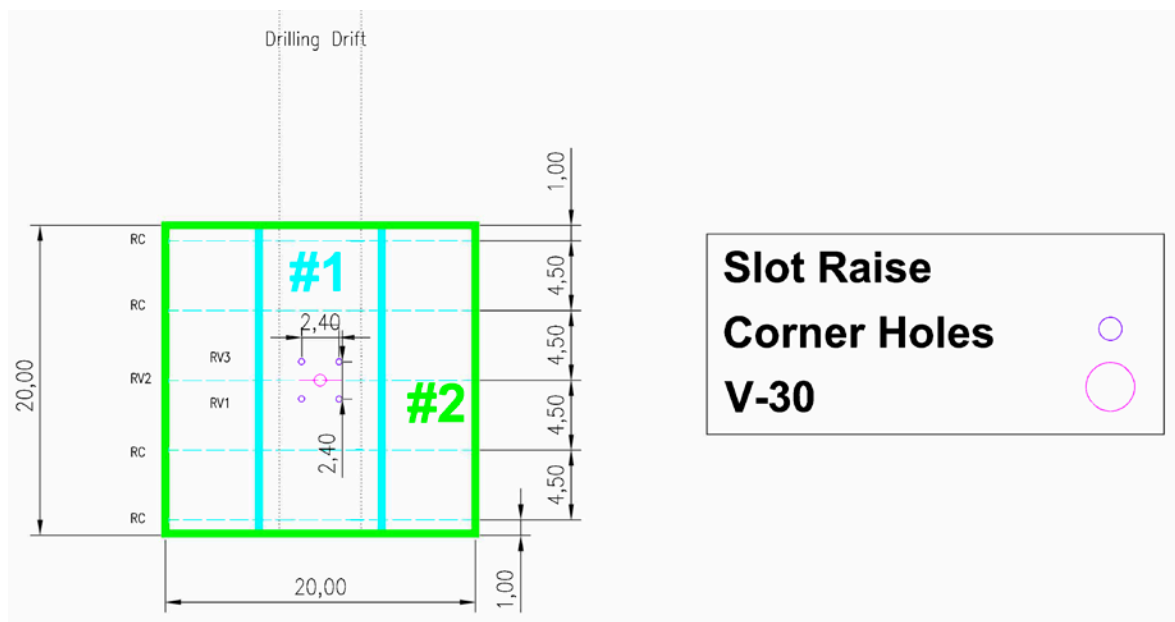

Figure 16-56: Plan view of a typical drilling pattern

### Drill and Blast Pattern No. 1

From level L750 to level L830, both stages of the blast will need to be decked because the slopes are too close to the surface. Thus, drilling and blasting pattern No. 1 will be applied.

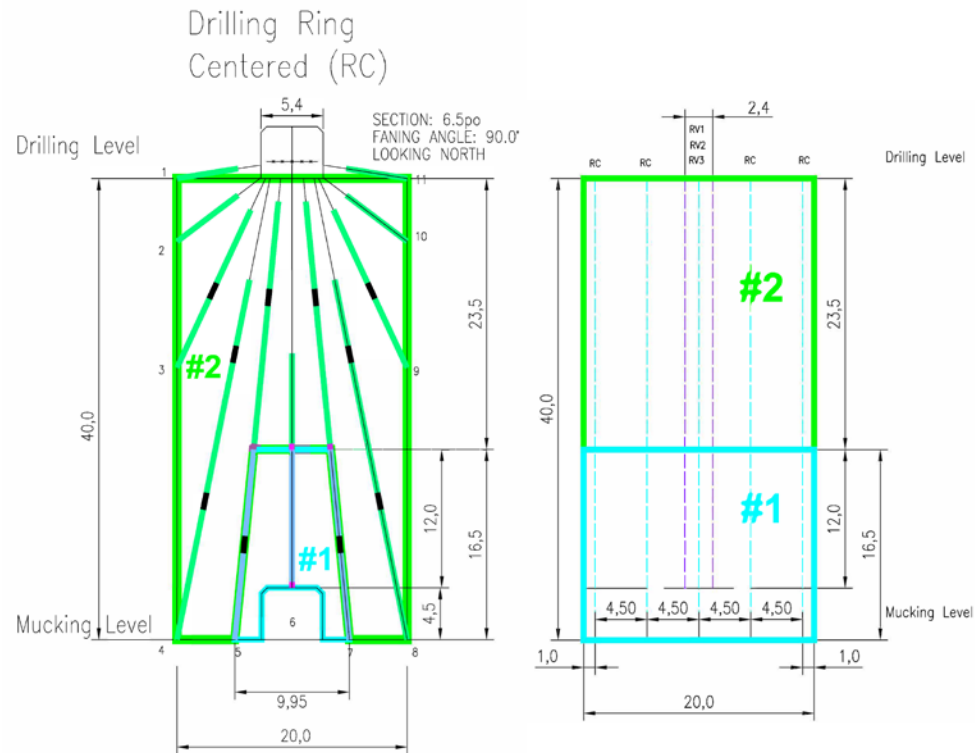

Figure 16-57: Typical drilling and blasting pattern for levels L710 to L830

### Drill and Blast Pattern No. 2

From level L870 to level L1110, only the second stage of the blast needs to be decked because the stopes are still fairly close to the surface. Thus, drilling and blasting pattern No. 2 will be applied.

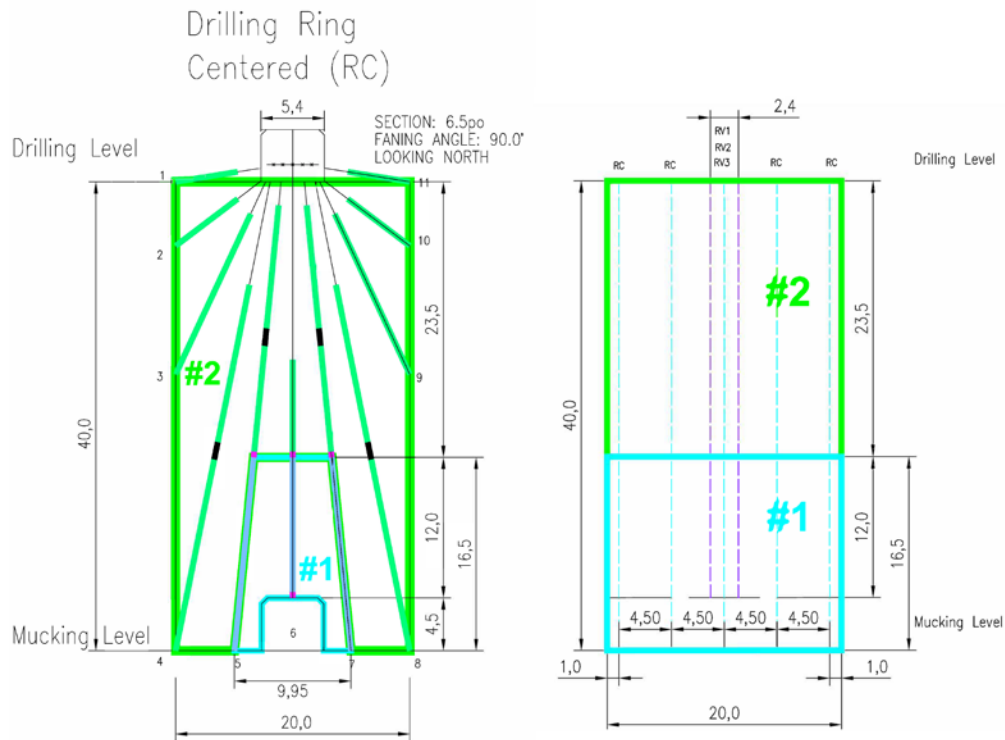

Figure 16-58: Typical drilling and blasting pattern for levels L870 to L1110

### Drill and Blast Pattern No. 3

From level L1150 to level L1310, there are no constraints on the vibration level. Depth is great enough to no longer have to limit charge per delay. Thus, drilling and blasting pattern No. 3 will be applied.

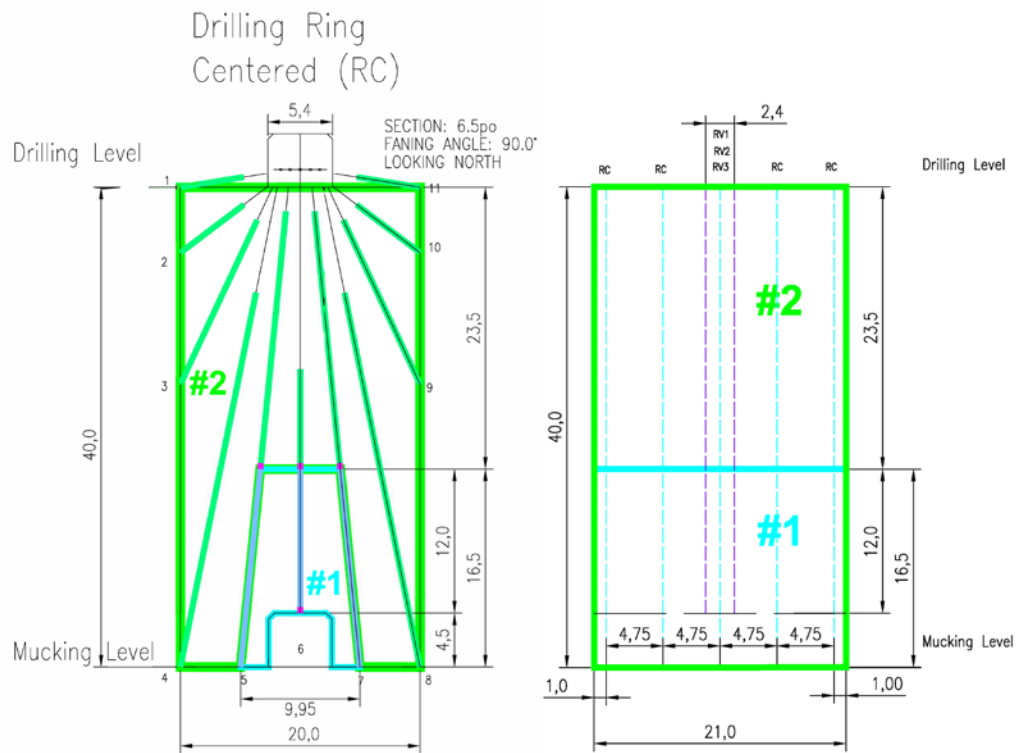
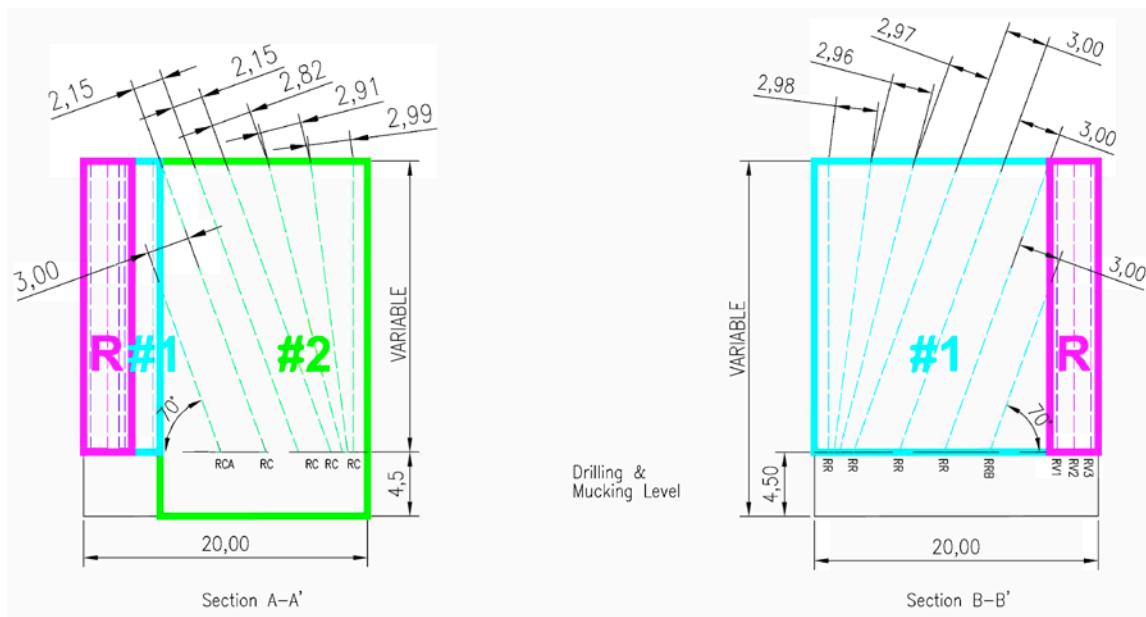
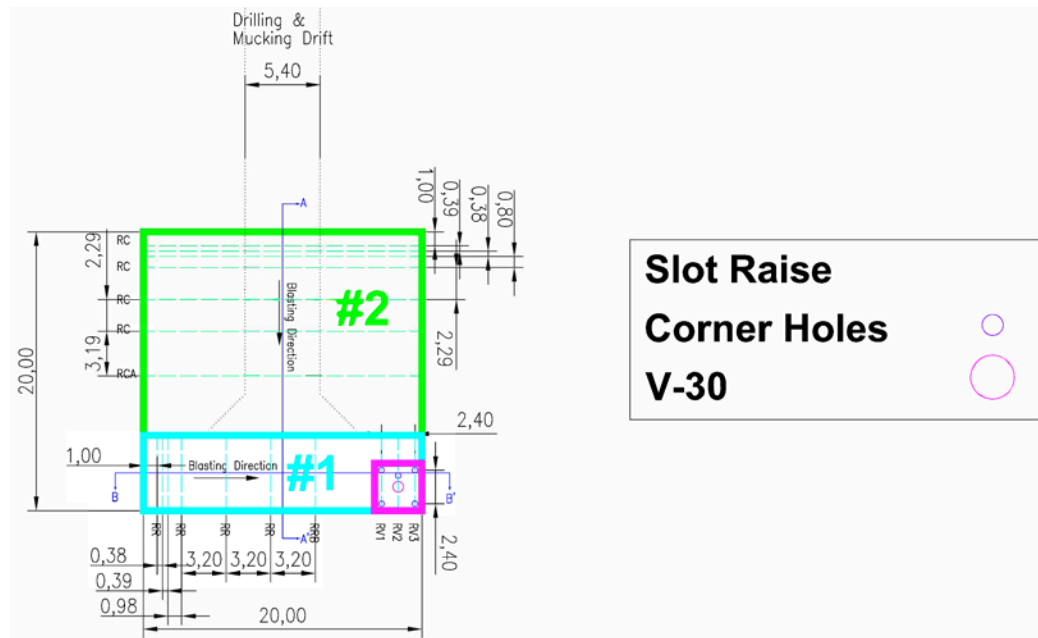

Figure 16-59: Typical drilling and blasting pattern for levels L1150 to L1310

### Drill and Blast Pattern No. 4

The stopes on level L710 will be drilled from the drift on level L710, thus creating upper stopes. The same scenario is planned on level L750 on the east side of the level. Drilling and blasting pattern No. 4 will be applied for these two levels. The next eight images show the particularity of this drill and blast pattern.



Rows RV1–RV3

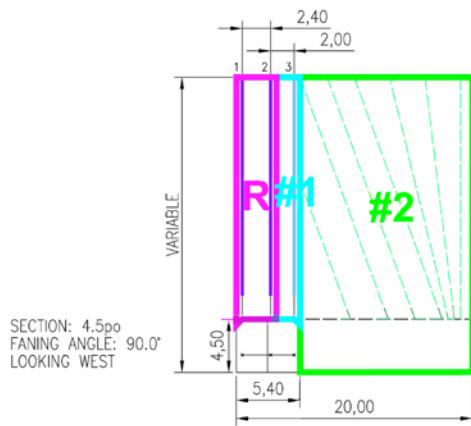

Section B–B'

Row RV2 (V–30)

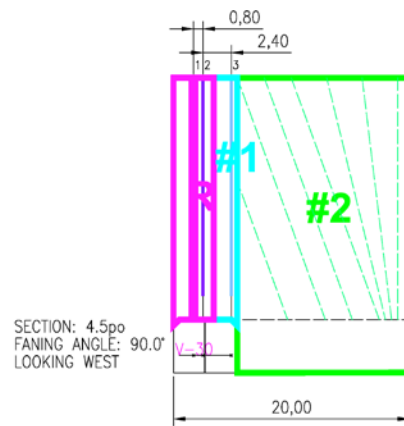

Section B–B'

Drilling Ring Raise (RR)

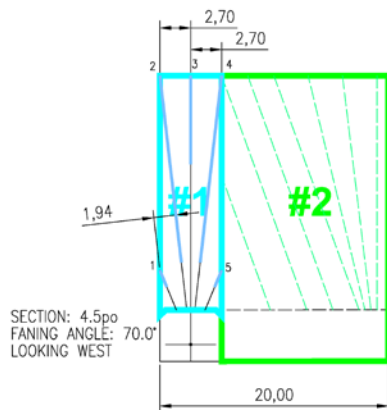

Section B–B'

Drilling Ring Raise (RRB)

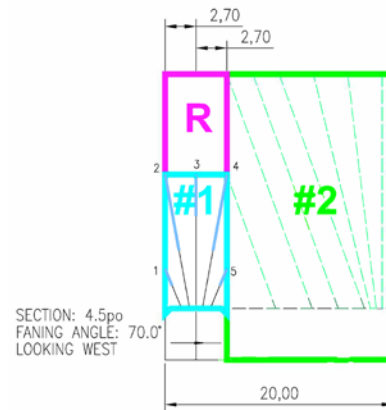

Section B–B'

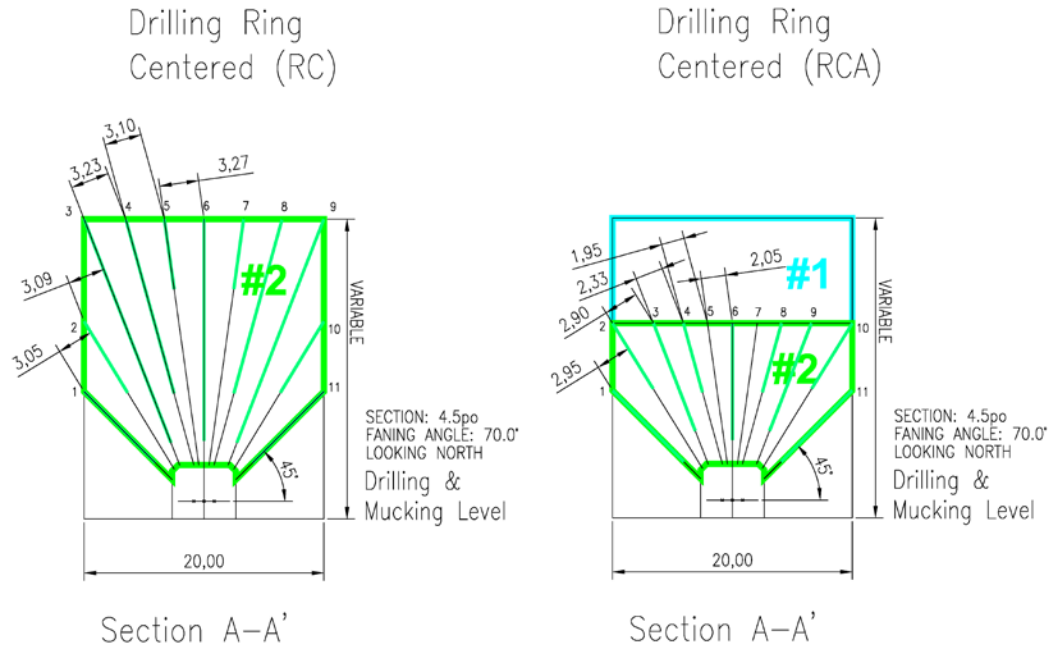
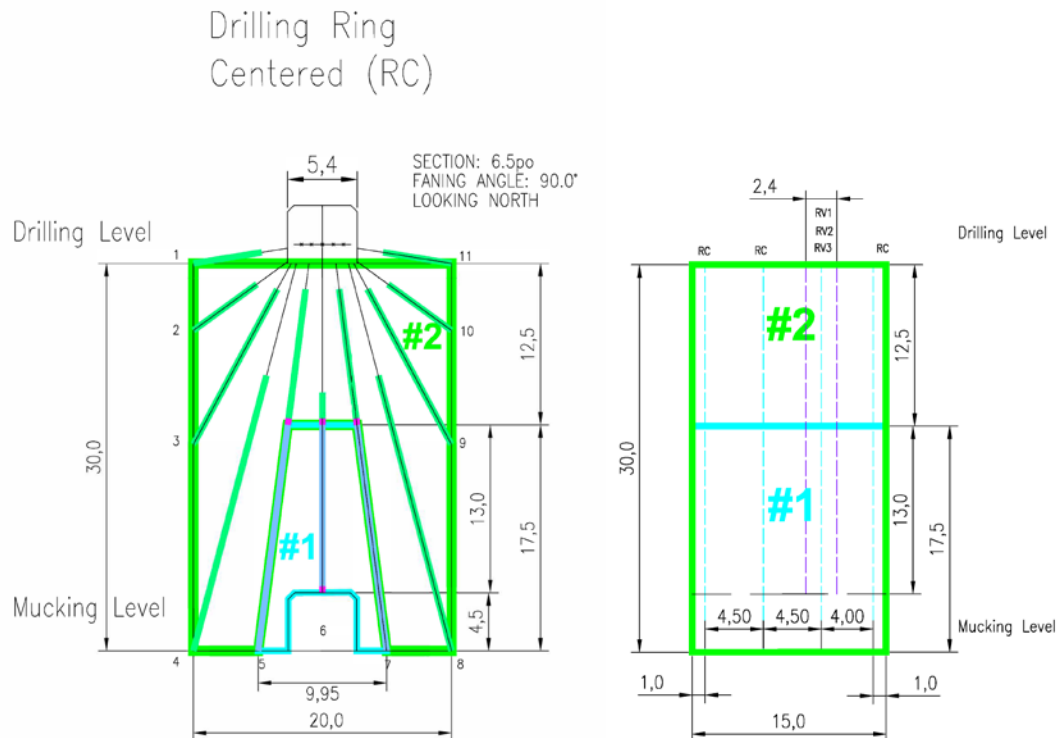

Figure 16-60: Typical drilling and blasting pattern for levels L710 and L750, upper stopes

**Drill and Blast Pattern No. 5 and No. 6**

From level L1340 to level L1880, the primary/secondary stope dimensions are not the same. Drilling and blasting pattern No. 5 will be applied to the primary stopes and the drilling and blasting pattern No. 6 will be applied to the secondary stopes. Patterns No. 5 and No. 6 do not apply on levels L1790 to level L1880 on the east side.

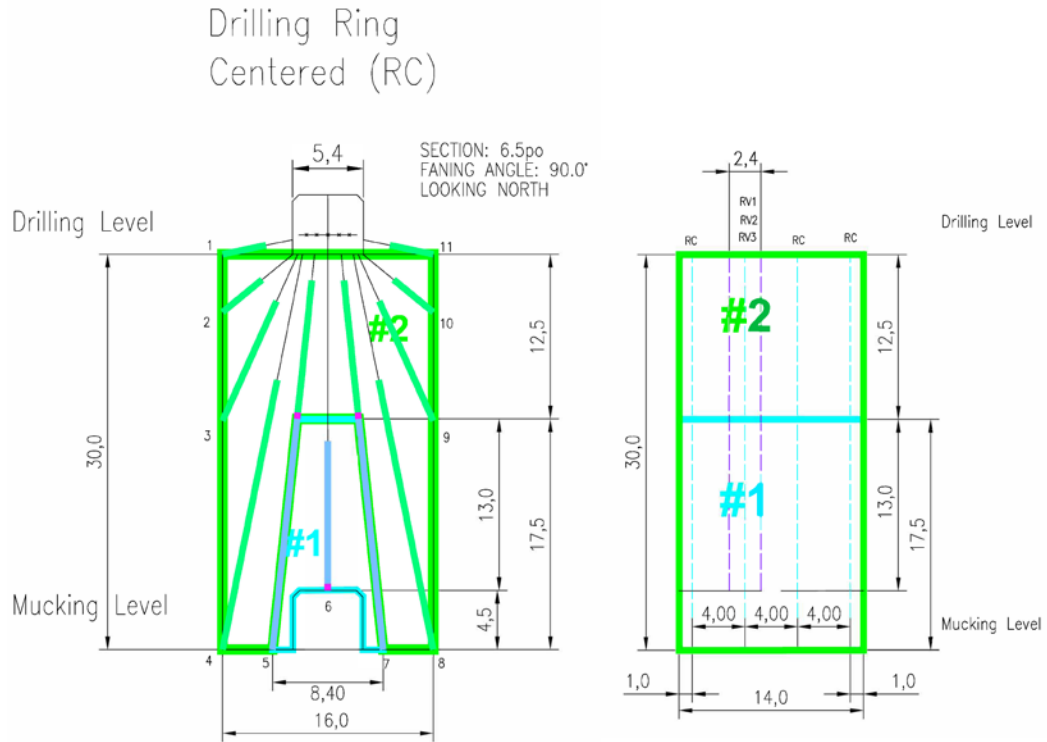

**Figure 16-61: Typical drilling and blasting pattern for levels L1340 to L1880**



**Drill and Blast Pattern No. 7**

From level L1910 to level L2060 and the east side of levels L1790 to L1880, the mining method will be pillarless and thus, the drilling and blasting pattern No. 7 will be applied.



**Figure 16-62: Typical drilling and blasting pattern for levels L1910 to L2060**

## Drill and Blast Pattern Summary

Table 16-23: Drilling and blasting pattern summary

Drilling and blasting pattern	Levels	Stope Width (m)	Stope Length (m)	Stope Height (m)	Charge max length (m)
<b>Pattern No.1: Two blasts</b>					
First blast decked Second blast decked	L750 to L830	20	19 to 21	40	13 to 16
<b>Pattern No.2: Two blasts</b>					
First blast full length Second blast decked	L870 to L1110	20	19 to 21	40	17 to 27
<b>Pattern No.3: Two blasts</b>					
First blast full length, Second blast full length	L1150 to L1310	20	21 to 22	40	29 to 35
<b>Pattern No.4: Two blasts</b>					
First blast full length Second blast full length	L710 and L750	20	19 to 21	22 and 25	22 to 25
<b>Pattern No.5: Two blasts</b>					
First blast full length Second blast full length	L1340 to L1880	20	14 to 17	30	No limits
<b>Pattern No.6: Two blasts</b>					
First blast full length Second blast full length	L1340 to L1880	16	17 to 22	30	No limits
<b>Pattern No.7: Two blasts</b>					
First blast full length Second blast full length	L1790 to L2060	16	12 to 15	30	No limits

### 16.7.4 Production Rate

Mineable resources will be accessed through the Quemont No. 2 shaft, which will be deepened to a final depth of 1,910 m. The mining sequence was split into two phases to allow the deepening of the shaft. Phase 1 will be from level L1310 to level L710. Phase 2 will be from level L2060 to level L1340. Each phase will be composed of several horizons in which pyramid sequences will be established as shown in Figure 16-63. The pyramids will allow many stopes to be available at any given time to allow flexibility, and the pyramids are sequenced to minimize stress issues that could potentially disrupt production.

The mine plan for the Horne 5 Project proposes a production rate averaging approximately 15,500 tpd of ore over the LOM. Calculations were performed assuming Sandvik LH621 LHDs with 20 t payloads and an expected average travelling distance of 200 m. The cycle times assume one minute of loading time per bucket, plus an additional one minute of unloading time. Each day assumes 20 productive hours of tele-operation, with 85% usage and availability rates. Under these assumptions, it is expected that each LHD has an average extraction capacity of 4,600 tpd for a combined production capacity of 18,400 tpd. One spare LHD has been considered to ensure the required LHD availability. Additionally, LH517 development LHDs will be equipped with tele-operation capabilities to ensure the required availability of LHD to serve as an additional backup or to temporarily increase production.

Production drilling will be carried out using four Sandvik DU4121 drills. The purchase of one spare drill has been considered. The proposed 4.5 m by 5.0 m drill pattern results in a production drilling ratio of 32.0 t/m. Each drill is expected to drill an average of 126 m per day, for a capacity of 16,128 tpd.

By early 2022, once the pyramidal mining sequence has achieved maturity, it is expected that a steady output of hoisted material will be maintained due to increased mining flexibility afforded by higher stope availability and thus allowing an approximate LOM average of 15,500 tpd to be mined.

In Phase 1, the mine plan provides for 866 stopes with an average of 50,000 t each (including dilution and a 95% mining recovery). Phase 1 will sustain the full production rate during the first six years. In year 2028, during the seventh year, Phase 2 stope extraction will start up progressively to establish the pyramidal production shape. Production will continue simultaneously in both Phase 1 and Phase 2 until year 2029 when Phase 1 will finally be depleted. For Phase 2, a total of 1,299 stopes are planned at an average tonnage of 26,600 t. Dimensions for stopes in Phase 2 are smaller than in Phase 1 to accommodate the higher stress levels at greater depth.

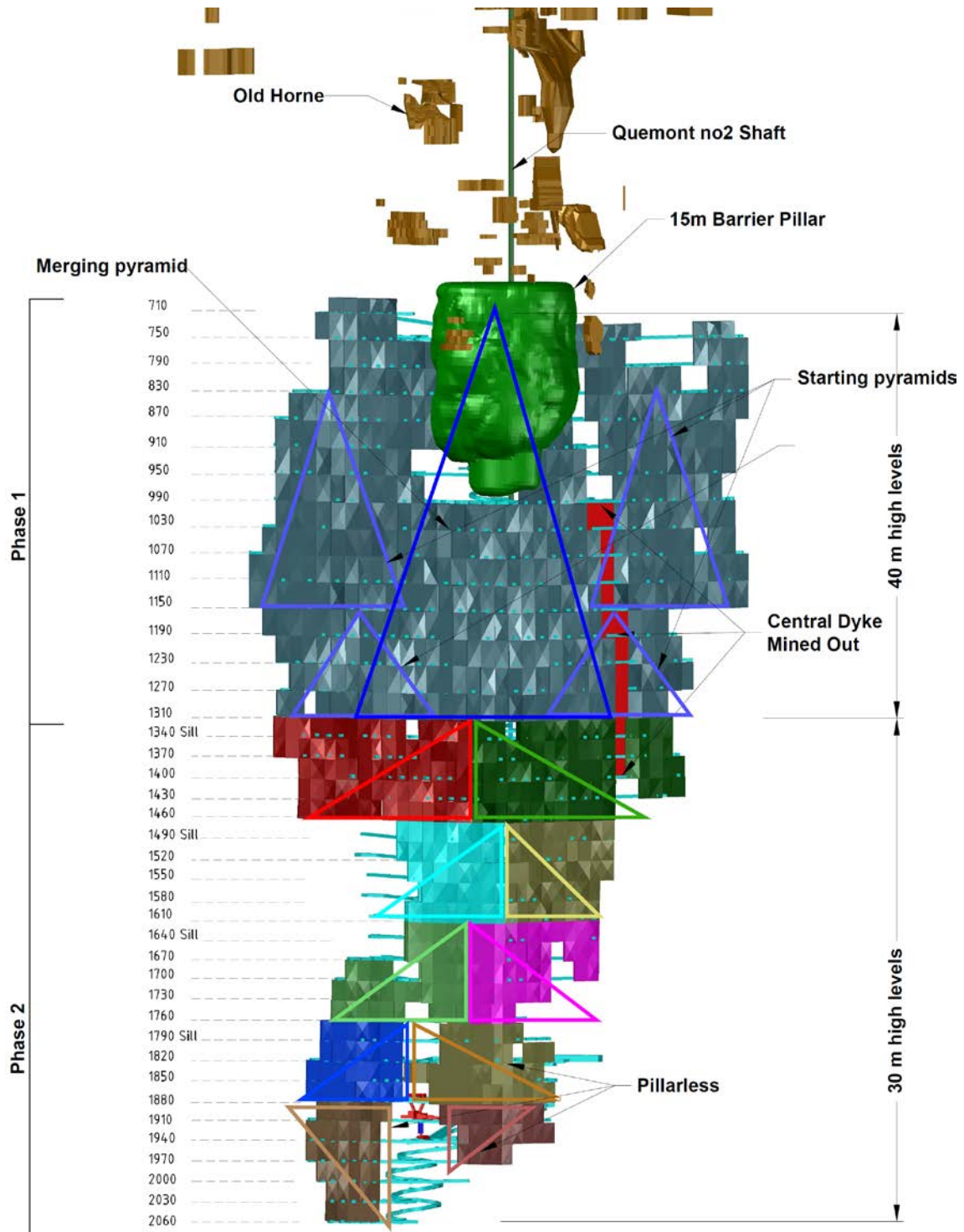

Figure 16-63: Production sequence for the Horne 5 Project

The proposed hoisting system is designed to achieve a production of 23,180 tpd during Phase 1 of production for the loading station at level Q1180 and 16,530 tpd during Phase 2 for the loading station at level Q1851. The shaft is designed for high-speed skip operation. If required, the system could hoist ore using one skip only from both loading stations at level Q1180 and Q1851 in the transition period between Phases 1 and 2., resulting in a production rate of 11,590 tpd. Production rates shown in the following tables are based on a hoist availability of 19 h/d for 335 d/y.

**Table 16-24: Hoisting parameters for loading station at level Q1180**

Parameters	Phase 1	Phase 2
Hoisting Distance	1,250 m	1,250 m
Loading Time	25.00 s	25.00 s
Acceleration	0.80 m/s <sup>2</sup>	0.80 m/s <sup>2</sup>
Deceleration	0.80 m/s <sup>2</sup>	0.80 m/s <sup>2</sup>
Hoisting Speed	18.00 m/s	18.00 m/s
Skip Cycle Time	127.00 s	127.00 s (one skip)
Skip Payload	43 t	43 t
Skip Capacity	43 t	43 t
Production Rate (per hour)	1,220 t/h	610 t/h
Production Rate (per day)	23,180 tpd	11,590 tpd

**Table 16-25: Hoisting parameters for loading station at level Q1851**

Parameters	Phase 2
Hoisting Distance	1,900 m
Loading Time	25.00 s
Acceleration	0.80 m/s <sup>2</sup>
Deceleration	0.80 m/s <sup>2</sup>
Hoisting Speed	18.00 m/s
Skip Cycle Time	163.00 s
Skip Payload	39.4 t
Skip Capacity	43 t
Production Rate (per hour)	870 t/h
Production Rate (per day)	16,530 tpd

### 16.7.5 Mining Sequencing: Panels, Primary and Secondary

The mining sequence for stope extraction will follow a 3D pyramidal shape, as shown in Figure 16-64, starting from the bottom in the hanging wall of the mineralization, and progressing toward the upper levels and the haulage drift or footwall.

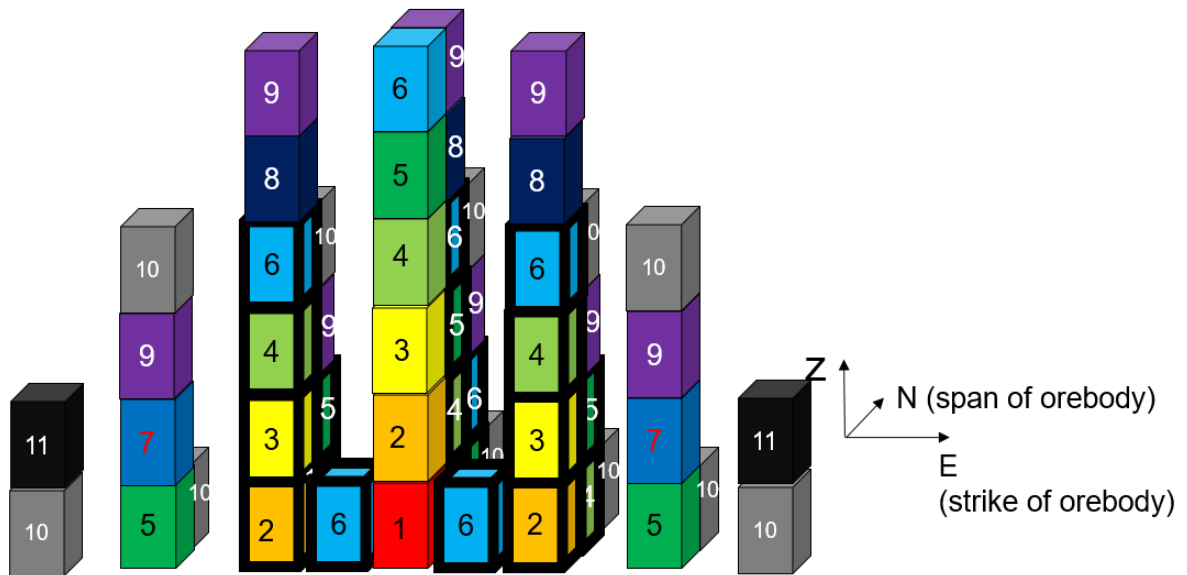

Figure 16-64: Pyramidal mining sequence

The flexibility of the sequence is limited by the following restrictions, most of which are due to rock mechanics constraints to limit stress concentration (see Figure 16-65):

- For a given section, mine 3 primary stopes up before starting the mining process in the adjacent panel.
- Similarly, for a given panel, mine 3 primary stopes up before starting the mining process in the adjacent primary sections.

Stopes backfilled with paste also add the following constraints to the mining cycle (Figure 16-65):

- Stopes *a* and *b* cannot be extracted during the same cycle: stope *a* requires a curing time of 28 days before blasting stope *b*, or conversely, stope *b* must be cured before blasting and mucking stope *a*;
- Stopes *c* and *d* can be extracted during the same cycle: supposing that *c* is extracted and the backfill barricade is installed before starting drilling stope *d* (no exposure);

- Considering the black block as waste (pillar), stopes *e* and *f* may be extracted during the same cycle: stope *e* is mined and backfilled, then stope *f* may start;
- For a given cycle, pyramid and level, a maximum of nine stopes can be mined out (LHD limits); and
- The secondary stope extraction may start only after two adjacent series of stopes of the primary draw points are mined and backfilled; i.e., the two-adjacent primary draw points and the two corresponding draw points on the upper level.

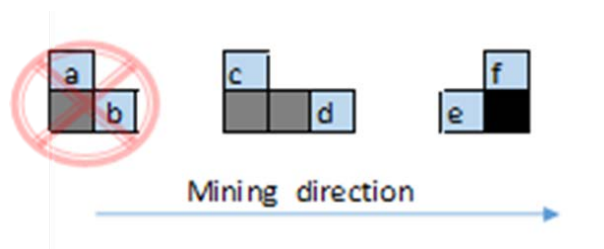

Figure 16-65: Illustration of mining sequence constraints (section view)

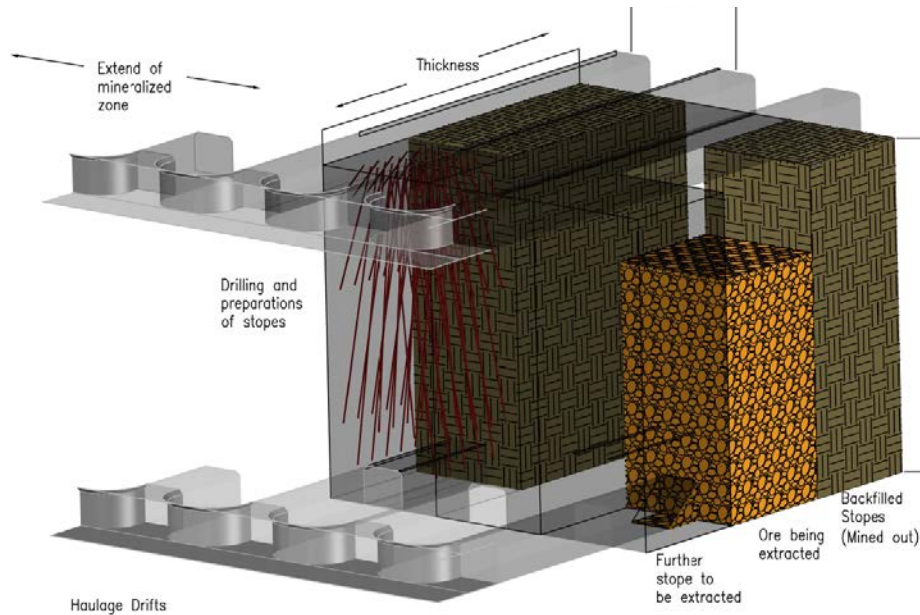

Figure 16-66: Isometric view of mining sequence



This sequence applies to all phases and allows several pyramids to progress simultaneously to achieve the production target. An isometric view of the mining sequence can be seen in Figure 16-66. For Phase 1, mining is possible on two different mining horizons. Two pyramids can start simultaneously from each extremities of the mineralized zone for each mining horizon. The start of these pyramids has been chosen to extract the best grade possible right from the beginning of production. The pyramids on each horizon will then be merged to reach the barrier pillar as soon as possible to reduce the impact on the historical Horne excavations and to not create any rib pillar. This approach is believed to be the most efficient given its amenability to the high degree of automation proposed.

The starting pyramids on horizons L1310 and L1150 split all levels in half. The sequence of these pyramids starts in the middle and progresses on each side. This sequence was chosen as to not create any stress accumulation in the diabase dike located in the eastern part of these levels. A 5 m thick stope will also be mined in the southern portion of the dike on each level, prior to adjacent stopes, to shadow the stress in the dike.

The pyramids between horizons L1880 and L1340 all start from the centre of the level going toward the extremities. This negates the creation of a rib pillar. Sill pillars that delineate mining horizons are mined out following the pyramidal production sequence

Finally, below level 1880, the pyramids will be inverted, going top down, to mitigate the risk of seismic activity.

### 16.7.6 Production Plan

A development and production schedule was developed based on the mineral resource estimate. The underground mine design provides for an approximate 15-year mine plan, producing 80,896,876 t of ore assaying 1.44 g/t Au, 0.17% Cu, 0.77% Zn and 14.14 g/t Ag, for an NSR value of 92.41 \$/t after dilution and mining recovery, using the November 2016 MRE.

Phase 1 produces 43,342,738 t excluding development, accounting for 53.5% of the mining production, while Phase 2 produces 34,558,058 t for 42.7% of the tonnage. Development is expected to generate 3,110,304 t for the remaining 3.8% of production.

Details of the production plan per phase and per year are presented in Table 16-26.



Table 16-26: Mine plan and yearly tonnage distribution (diluted)

		Phase1	Phase2	Total	NSR
		t	t	t	\$
Preproduction	Stopes				
	Development	187,080		187,080	88.32
	<b>Total</b>	<b>187,080</b>		<b>187,080</b>	88.32
2021	Stopes	2,024,586		2,024,586	102.94
	Development	562,136		562,136	81.66
	<b>Total</b>	<b>2,586,722</b>		<b>2,586,722</b>	98.32
2022	Stopes	5,676,548		5,676,548	90.81
	Development	190,252		190,252	96.19
	<b>Total</b>	<b>5,866,801</b>		<b>5,866,801</b>	90.98
2023	Stopes	5,635,843		5,635,843	86.99
	Development	185,274		185,274	96.41
	<b>Total</b>	<b>5,821,118</b>		<b>5,821,118</b>	87.29
2024	Stopes	5,687,214		5,687,214	89.64
	Development	164,439		164,439	98.01
	<b>Total</b>	<b>5,851,653</b>		<b>5,851,653</b>	89.88
2025	Stopes	5,673,104		5,673,104	83.79
	Development	155,095		155,095	98.95
	<b>Total</b>	<b>5,828,198</b>		<b>5,828,198</b>	84.19
2026	Stopes	5,711,961		5,711,961	92.46
	Development	130,203		130,203	98.48
	<b>Total</b>	<b>5,842,164</b>		<b>5,842,164</b>	92.60
2027	Stopes	5,459,817		5,459,817	92.89
	Development	67,607		67,607	96.50
	<b>Total</b>	<b>5,842,164</b>		<b>5,842,164</b>	92.94
2028	Stopes	4,785,164	704,998	5,490,163	85.61
	Development		183,055	183,055	95.69
	<b>Total</b>	<b>4,785,164</b>	<b>888,053</b>	<b>5,673,217</b>	85.94
2029	Stopes	2,574,276	2,841,279	5,415,555	91.66
	Development		305,062	305,062	104.41
	<b>Total</b>	<b>2,574,276</b>	<b>3,146,341</b>	<b>5,720,617</b>	92.34

		Phase1	Phase2	Total	NSR
		t	t	t	\$
2030	Stopes		5,513,148	5,513,148	97.01
	Development		261,888	261,888	107.04
	<b>Total</b>		<b>5,775,037</b>	<b>5,775,037</b>	97.46
2031	Stopes		5,607,355	5,607,355	97.37
	Development		189,580	189,580	107.59
	<b>Total</b>		<b>5,796,934</b>	<b>5,796,934</b>	97.70
2032	Stopes		5,646,774	5,646,774	98.97
	Development		149,474	149,474	106.41
	<b>Total</b>		<b>5,796,248</b>	<b>5,796,248</b>	99.16
2033	Stopes		5,620,609	5,620,609	100.12
	Development		149,474	149,474	106.41
	<b>Total</b>		<b>5,770,082</b>	<b>5,770,082</b>	100.29
2034	Stopes		5,536,997	5,536,997	89.73
	Development		117,271	117,271	108.82
	<b>Total</b>		<b>5,654,268</b>	<b>5,654,268</b>	90.12
2035	Stopes		3,086,898	3,086,898	87.86
	Development		112,415	112,415	107.86
	<b>Total</b>		<b>3,199,313</b>	<b>3,199,313</b>	88.57
Totals	<b>Stopes</b>	<b>43 228 514</b>	<b>34 558 058</b>	<b>77 786 572</b>	<b>\$ 92.19</b>
	<b>Development</b>	<b>1,642,086</b>	<b>1,468,217</b>	<b>3 110 304</b>	<b>\$ 97.71</b>
	<b>Total</b>	<b>44 870 600</b>	<b>36 026 275</b>	<b>80 896 876</b>	<b>\$ 92.41</b>

## 16.8 Cemented Paste Backfill

### 16.8.1 Paste Plant Capacity

Two key aspects that influence the design of the underground distribution systems for both the paste backfill and tailings slurry are the capacity of the paste plant and secondly, the mix design. The plant capacity will determine the flow rates for all of the process streams, whereas the mix design is determined in order to achieve the required backfill strength at the lowest binder content while maintaining a material that can be pumped or delivered by gravity.

The plant capacity design for the project is based on the use of 12,065 tpd of dry tailings for the backfilling of mining voids generated by ore extraction in any given year. Such plant capacity allows an overall plant utilization of approximately 60%, which is typical for a paste backfill operation. Because the Horne 5 orebody is mostly dipping vertically, it is possible to distribute the paste by gravity and avoid the operation of a pumping system. Accordingly, in order to maximize the delivery of the paste by gravity, the slump of the paste was adjusted to 200 mm (8 in) for the Project. In addition, the mineralogy of the orebody was considered in the selection of the paste backfill recipe. Preference was given to the use a blend comprised of 50% PCT and 50% PFT for the mixture. Considering the selected rate of paste plant production, the total expected production of PCT will be incorporated in the paste backfilled when the plant operates, which in turn will limit the amount of PCT to be stored on surface.

## 16.8.2 Material Testing

Laboratory tests on tailings were performed partly by Golder and partly by the URSTM. Golder performed a dewatering/filtering investigation as well as basic rheology. URSTM (2017) performed a backfill strength investigation program for the selection of the cement percentage. Tests were performed on PFT and PCT alone but also on blends of both, i.e., at ratios of 63% PFT / 37% PCT and 50% PFT / 50% PCT. The test results are presented in a technical memorandum (Golder, 2017d) and in URSTM (2017). A summary of the results is presented in the following section since those results have a direct influence in the design of the paste backfill and slurry tailings underground distribution systems.

### Material Characterization

Table 16-27 and Figure 16-67 provide the specific gravity (“SG”) and particle size distribution (“PSD”) of the two tailings samples measured by Golder.

Table 16-27: Material properties

	PFT	PCT
Specific Gravity	2.76	4.44
<b>Particle Size Distribution</b>		
P <sub>80</sub> (µm)	48	9
P <sub>50</sub> (µm)	21	5
P <sub>10</sub> (µm)	4	1

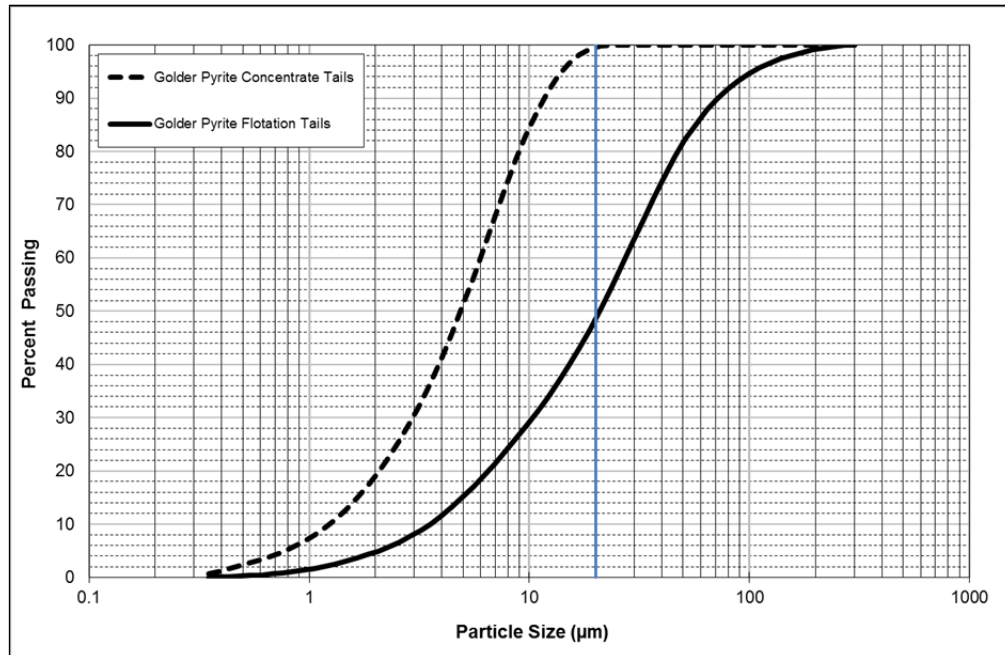

Figure 16-67: Particle size distribution

### Filtration Test Work

To achieve the required slump consistencies for the cemented paste backfill, and independent of the final tailings blend, it will be necessary to filter a portion of the tailings streams. Filtration test work examined vacuum and pressure filtration. The test work revealed low cake loading values with vacuum filtration. For this reason, pressure filtration will be needed and tests were conducted using a bench-scale testing unit. The testing was performed with the unit set up to simulate the recessed with membrane-squeeze chamber plate configuration. The filtration tests were performed using a filter cloth with an air permeability of  $0.57 \text{ m}^3 \text{ air/m}^2 \text{ media/min}$ . The test conditions and results are presented in Table 16-28. The tests were run under similar conditions, and while no attempts were made to optimize cycle times, they do provide initial values regarding the filterability of various tailings composition.

Table 16-28: Pressure filtration results

Process Parameter	100% PFT	63% PFT/ 37% PCT	50% PFT / 50% PCT	100% PCT
Chamber Thickness (mm)	32	32	32	32
Starting Feed Pressure (bar)	6.9	6.9	6.9	6.9
Starting Squeeze Pressure (bar)	7.4	7.4	7.4	7.4
Starting Cake Blow Pressure (bar)	6.9	6.9	6.9	6.9
Feed (wt% solids)	62.0	55.5	53.5	47.0
Calculated Cycle Time (min)	11.5	15.5	17.5	25.5
▪ Feed time (min)	2	6	8	16
▪ Squeeze Time (min)	3	3	3	3
▪ Air Blow Time (min)	2	2	2	2
▪ Technical Time (min)	4.5	4.5	4.5	4.5
Filtration Rate (kg/m <sup>2</sup> /hr)	131	115	108	83
Final Cake Moisture (%)	21.2	17.5	16.9	16.7

### Paste Backfill Recipe

As described in Section 16.2.10, the backfill strength to be achieved at 28 days after the end of a pour is 1 MPa. A second value of 170 kPa is the target strength typically used to prevent liquefaction and often used as a target for secondary stopes where there will be no exposed face during the mining cycle.

Varying the tailings mixtures, the water and the cement contents, different cemented paste backfill recipes were tested by URSTM (2017) with curing times varying from 14 to 90 days. The results confirmed that a mixture comprised of 50% PFT / 50% PCT at a 200 mm (8 in) slump was an appropriate mix design when using 80% Blast Furnace Slag and 20% General Use cement as the binder agent. The Uniaxial Compressive Strength (“UCS”) results are presented in Figure 16-68.

Based on these results, the recommended binder requirements for aforementioned strength requirements are:

- 3.5% of 80% Blast Furnace Slag and 20% General Use cement for the 1 MPa;
- 2% of 80% Blast Furnace Slag and 20% General Use cement for the 170 kPa.

A portion of the ore tonnage (representing approximately 4%) mined in the stopes located within 65 m of the historic Horne mine would require 5% of 80% Blast Furnace Slag and 20% General Use.

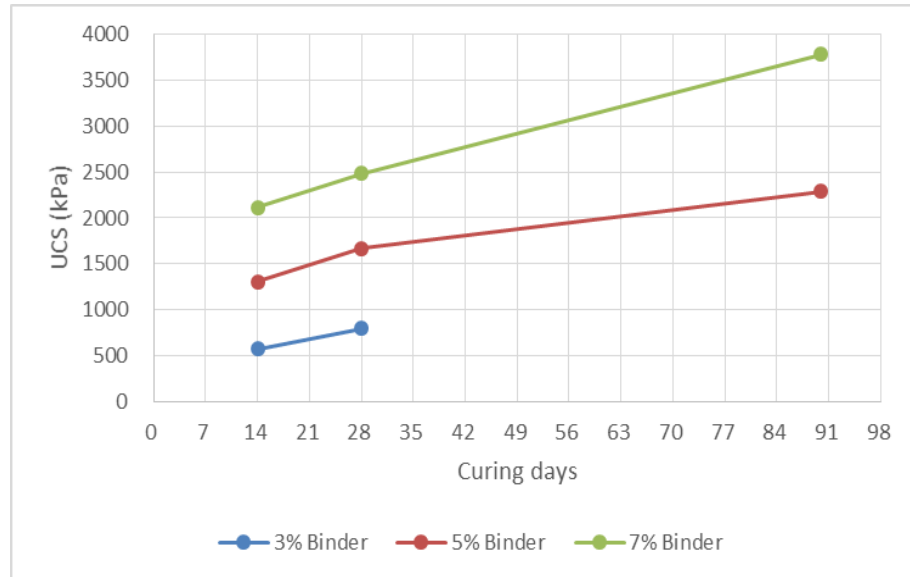

Figure 16-68: Cemented paste backfill strength results

### 16.8.3 Paste Backfill Underground Distribution System (“UDS”)

Paste backfill is required for structural support in the mined out Horne 5 stopes. Since the paste plant design will include two parallel circuits, the paste backfill UDS is based on operating a distribution line for each of the circuits. Therefore, all piping and boreholes will be twinned for the paste distribution system. Redundancy will also be built into the system; thus, four boreholes will be drilled from surface to underground. For all interconnecting underground boreholes there will also be four boreholes; two operating and a spare for each. Based on the capacity of the paste plant, on the overall utilization rate of 60% and on the mining sequence, paste backfill is not required for two stopes concurrently on the same sections (east or west) of the levels. Thus, the pipeline on each level will not be twinned.

The paste backfill delivery system is based on filling the first two phases of the Horne 5 Mining Complex. The two phases, with the level numbers representing the approximate distances in metres below surface, i.e., surface is 0 Level (L), are defined as follows:

- Phase 1: L710 to L1310;
- Phase 2: L1340 to L2060.

The paste backfill UDS was examined based on the life of mine of Horne 5 to determine the pressures in the system covering the extent of the mining operations for the various levels and phases of mining.

## Friction Loss

Friction losses of 10.6 kPa/m and 14.3 kPa/m were estimated for 250 mm and 200 mm (10 in and 8 in) diameter pipelines for cemented paste backfill using the viscosity, dynamic yield stress and PSD results obtained during testing of the tailings (Golder, 2017d). This estimation considers a flow rate representing half of the expected dry tailings production used for the paste backfill (12,065 tpd) having a slump of 200 mm (8 in) in each pipeline of 250 mm and 200 mm (10 in and 8 in) schedule 80 and includes a 10% factor of safety (“FoS”). The 250 mm (10 in) section of the UDS is required for the main boreholes from surface to L322 and from L322 to L710 and piping on L322, allowing the system to run by gravity; the remaining distribution system (i.e. boreholes and piping) is 200 mm (8 in) in diameter.

## Paste Backfill Delivery System

The main boreholes will be drilled from the surface to the L322 of Horne 5. From the bottom of these main boreholes, two pipelines are run on the drift to another series of boreholes to the L710. The L710 represents to top section of Horne 5 and the main connection from the surface to Horne 5.

From the L710 at Horne 5, interconnecting boreholes will be drilled near the main ramp in rock to connect the pipeline to each mining level. Boreholes will be drilled from drilling platforms every level; as a result, the underground interconnecting boreholes are in the range of approximately 329 m to 57 m long and will be drilled to angles from approximately 44 to 83 degrees (°).

The first level requiring paste is the L1270 (Phase 1). Paste delivered to the L1270 will fill stopes between the L1270 and L1310. The underground interconnecting boreholes that form the permanent paste backfill delivery system will not be complete in time to deliver paste backfill to the L1270. Therefore, in order to delivery paste backfill to L1270, the following boreholes will be drilled:

- L322 to L750;
- L750 to L1190;
- L1190 to L1270.

Figure 16-69 shows the paste backfill delivery from the surface to Horne 5.

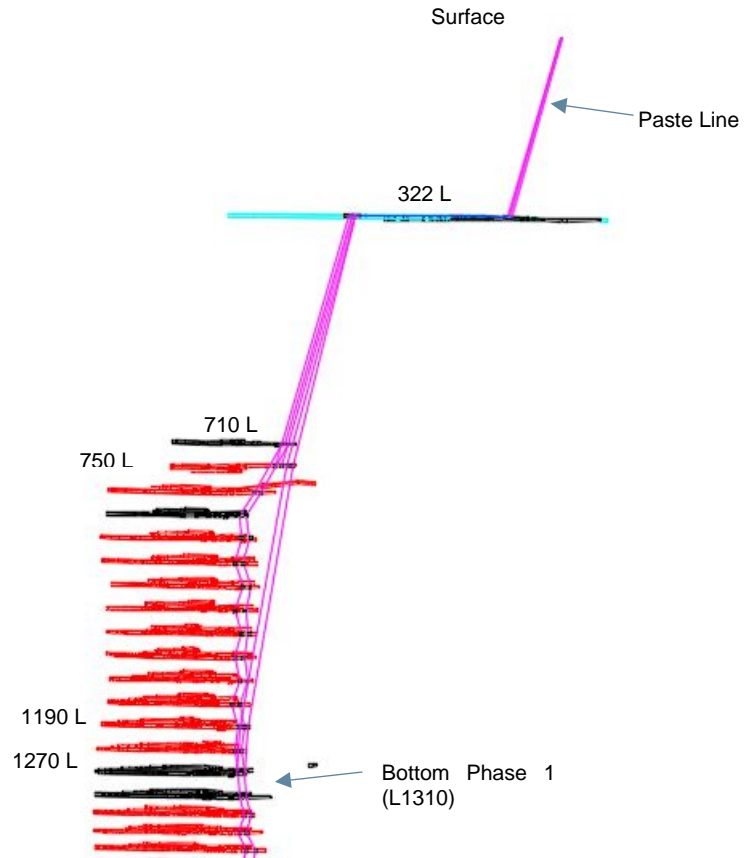

Figure 16-69: Cemented paste backfill distribution for Horne 5 Mining Complex

A summary of the boreholes for the paste backfill distribution for Phases 1 and 2 at Horne 5 is presented in Table 16-29. It is important to note that only the boreholes to the L1270 are required for the first two years of operation, corresponding to the capital investment for the UDS. The remainder of the expenditures related to the boreholes and pipelines to deliver cemented paste backfill to the end of Phase 2 is included as sustaining capital.



Table 16-29: Borehole summary for paste backfill distribution

Borehole	Collar Location	Toe Location	Diameter (mm)	Length (m)	Angle (°)	Number of Holes
Main Borehole	Surface	L322	250	327	68	4
710	L322	L710	250	445	62	4
750	L322	L750	250	477	64	4
750	L710	L750	200	38	71	3
790	L750	L790	200	202	23	4
830	L790	L830	200	46	54	3
870	L870	L870	200	41	80	3
910	L870	L910	200	42	72	3
950	L910	L950	200	43	69	3
990	L950	L990	200	42	71	3
1030	L990	L1030	200	43	70	3
1070	L1030	L1070	200	42	74	3
1110	L1070	L1110	200	41	76	3
1150	L1110	L1150	200	46	70	3
1190	L750	L1190	200	483	66	4
1190	L1110	L1190	200	48	50	3
1230	L1190	L1230	200	40	82	3
1270	L1190	L1270	200	80	87	3
1270	L1230	L1270	200	40	82	3
1310	L1270	L1310	200	58	44	3
1340	L1310	L1340	200	32	72	3
1370	L1340	L1370	200	32	70	3
1400	L1370	L1400	200	33	67	3
1430	L1400	L1430	200	34	77	3
1460	L1430	L1460	200	30	78	3
1490	L1460	L1490	200	32	69	3
1520	L1490	L1520	200	31	74	3
1550	L1520	L1550	200	33	65	3
1580	L1550	L1580	200	31	78	3
1610	L1580	L1610	200	32	72	3
1640	L1610	L1640	200	31	73	3
1670	L1640	L1670	200	35	59	3

Borehole	Collar Location	Toe Location	Diameter (mm)	Length (m)	Angle (°)	Number of Holes
1700	L1670	L1700	200	35	60	3
1730	L1700	L1730	200	32	68	3
1760	L1730	L1760	200	32	71	3
1790	L1760	L1790	200	29	74	3
1820	L1790	L1820	200	62	32	3
1850	L1820	L1850	200	34	64	3
1880	L1850	L1880	200	32	73	3
1910	L1880	L1910	200	30	76	3
1940	L1910	L1940	200	33	66	3
1970	L1940	L1970	200	31	77	3
2000	L1970	L2000	200	31	71	3
2030	L2000	L2030	200	31	75	3

Some Lateral development is required to tie in the interconnecting boreholes to the filling levels. The amount of lateral development has been optimized during the layout of the boreholes to ensure the shortest possible route is achieved between the borehole and the level access.

Level piping is installed on every level from the bottom of an interconnecting borehole. Two pipelines run on to each level from the bottom of the boreholes. Based on the mining sequence, one pipeline runs to the east stopes and one to the west stopes, allowing filling to occur simultaneously on each level but not in the same direction.

The paste backfill UDS was designed with the intent that the system will run as full as possible at the design flow rate. In other words, when there is “free fall” in the boreholes, the amount of paste in the borehole is kept as full as possible. During the mining of Phase 2, additional piping will be required on the levels to increase the pressures in the system, keeping the amount of paste backfill in free fall to a minimum.

It is understood that the rock near surface is fractured. Therefore, the main boreholes from surface to underground will be cased because of the potential for water inflow. Boreholes will be cased with 250 mm (10 in) ASTM A53 Gr. B schedule 80, carbon steel pipe casing with threaded ends and the cased piping grouted in place.

As previously mentioned, back-up boreholes will be drilled for all the boreholes in the paste backfill UDS to provide redundancy in the system. Redundancy reduces lost time for paste backfill production in case a borehole is damaged or plugged.

For safety reasons, cemented paste backfill will also be used to backfill the Horne mine on the levels where the Horne 5 development and mining activities will intersect the historical Horne drifts and voids. To fill these voids, cemented paste backfill will be used to get non-liquefiable material near the Horne 5 operation and to allow development through the paste where new development will intersect historical mine workings. For this reason the drifts and voids below HL13 (Horne 5 L474) in the former Horne mine will be filled using cemented paste backfill. This will be accomplished using the paste plant and reticulation system.

The estimated volumes of cemented paste backfill required to backfill these levels and voids are respectively 456,502 m<sup>3</sup> and 176,742 m<sup>3</sup> for the Phase 1 and the Phase 2 of the Project. For Phase 1, the paste backfill distribution system requires access to historic development from the new development with short boreholes and the rehabilitation of the level 9 (Horne 5 L322) to backfill levels 13 to 19 (Horne 5 L710) with cemented paste.

### Underground Piping

The underground pipelines consist of two different types of pipe:

- High pressure, carbon steel schedule 80 (ASTM A53 Gr. B) piping with Victaulic HP-70ES couplings.
- Low pressure high-density polyethylene (“HDPE”) DR9 piping, butt fused with flange ends.

The underground piping is generally installed as follows:

- High pressure grooved piping is installed on all main lines underground. The high pressure piping is installed even in main line areas where the pressure is not expected to be high since the thicker wall results in a longer wear life and less requirement for change-out of the system.
- Low pressure piping is typically the final pipeline run into the stopes. The HDPE piping is also lighter and easier to handle.

Underground piping requires substantial bracing. All elbows and changes in direction require angle bracing to the back and walls for resistance to the high forces on the pipe resulting from the high pressures generated and dynamic forces emanated from charging the pipeline. Level pipe supports are required every 3 m (10 ft) and at the toe and collar of every borehole.

Although it is intended that the mine avoid pipeline plugging through regular flushing, it is best to plan for this possibility; thus, the pipeline has a pressure release device located on each level. The pressure release device is the shape of a grooved tee that fits in line with the existing level pipeline. If the pipeline becomes blocked, the pressure release tee allows an operator to safely open and depressurize the pipeline before the binder can hydrate in the line.

The amount of pipeline required to service Horne 5 in the first two years of mining is estimated and shown in Table 16-30.

**Table 16-30: Piping to install at Horne 5 during the preproduction phase (first two years of mining)**

Level	Total High Pressure Piping (m)	Total Low Pressure Piping (m)
L322	1,100	-
L710	680	-
L750	640	-
L790	680	-
L830	700	325
L870	720	275
L910	780	300
L950	800	350
L990	800	650
L1030	780	50
L1070	780	150
L1110	760	350
L1150	760	675
L1190	740	1075
L1230	700	600
L1270	800	650
<b>Total</b>	<b>12,220</b>	<b>5,450</b>

Additional high pressure (39,244 m) and low pressure (46,765 m) piping are also budgeted in sustaining capital for the Project. These costs are evenly distributed between 2023 and 2031.

### Flow Modelling

Flow modelling was performed to confirm the hydraulic design of the pipeline. The flow model balances the hydraulic head available with the friction losses present in the pipeline. The pipeline routing is inserted into the flow model and then the pressures in the pipeline system are determined. The flow model helps to refine the pipeline specification, and dictates whether the paste backfill will be gravity fed or pumped into the UDS. The model is adjusted to various friction factors, corresponding to various slumps until the system can be gravity fed or until the operating parameters of a typical paste pump can be achieved.

In general, the hydraulic grade line of the hydraulic design is reviewed to ensure the following:

- The hydraulic grade line must be below the maximum allowable operating pressure of the pipeline.
- Slack flow, i.e., free fall, should be reduced as much as possible (which increases wear on the borehole casing and components).

The flow models are calculated under the assumption that the throughput is at the design mass flow rate of 251 tph of solids. The flow models were calculated based on delivering a 200 mm (8 in) slump for gravity flow to each level of Horne 5. This requires that the cased boreholes from surface to L322 and from L322 to L710 be 250 mm (10 in) in diameter (including 250 mm (10 in) piping installed on the L322), whereas the rest of the UDS would be composed of 200 mm (8 in) diameter pipes and boreholes. The flow models also indicate the paste backfill velocity of 1.2 m/s, an acceptable velocity for paste backfill.

Because the system is designed to flow by gravity, it should be noted that the hydraulic grade line falls below the pipeline profile at the start of the UDS for all areas at Horne 5, indicating slack flow in the first section. However, the flow models indicate positive pressure at the bottom of the main borehole, signifying that the overall UDS system is running close to full. The initial slack flow does not impede UDS operations.

There are some areas in Phase 1 that will require a higher slump (greater than 200 mm) in order for the paste backfill to be delivered by gravity. This is a result of the amount of horizontal piping on the levels to reach the stopes to the extents of the orebody. The higher slump will reduce the friction losses in the line, and thus the overall pressure in the system. In order for the paste backfill to flow by gravity to the levels extents, slump control will be a critical component during the operation of the paste backfill plant.

## Flushing

Flushing is an important aspect of the underground distribution system. There are two main flushing sequences: a pre-operating flush and a flush at the end of a pour. The pre-operation flush ensures that the paste pipeline (boreholes and level piping) has no blockages and is open ended at the appropriate deposition location. This pre-flush needs to be confirmed with the surface operator before starting the backfilling operation. If possible, the discharge from this flush should be observed to confirm that the water is exiting the pipeline cleanly. The pre-flush also serves to wet the line. Under normal shutdown conditions, the paste plant should be watching the stope via camera or communicating with the underground operation to determine when the stope is full. At this time, one or multiple flushes are used to clean the equipment and the pipeline. For practical purposes, the water flushed underground through the pipeline should not be discharged in the stope but rather diverted onto the distribution level.

Table 16-31 provides a preliminary estimate of the flush volumes of water per year. The volumes are based on the length of pipeline to reach each level based on the flow model discussed in the previous section, and the number of stopes mined on the various levels each year with two pours per stope, one for the plug and one for filling the remainder of the stopes. The water flushing volume is equal to two borehole/pipeline volumes per pour.

**Table 16-31: Estimate of the flush water volumes per year**

Year	No of Stopes Mined	Total Volume (m <sup>3</sup> )
2021	38	17,499
2022	108	49,730
2023	104	47,892
2024	112	51,576
2025	109	50,195
2026	115	52,958
2027	115	52,958
2028	132	60,786
2029	154	70,917
2030	195	89,798
2031	214	98,547
2032	215	99,008
2033	215	99,008
2034	209	96,245
2035	130	59,865

### Underground Instrumentation

To monitor and troubleshoot the underground distribution system, operation pressure transducers and cameras are required.

Pressure transmitters will be installed at the bottom of the boreholes and will transmit the data via the mine's communication system to the paste backfill plant control system on the surface. Pressure transmitters will also be installed on the first section of the paste distribution lines. Information on the pressures in the UDS will allow operators to observe the long-term fluctuations in pressures in the pipeline, as well as allow operators to respond to upset conditions such as a blockage or rupture of the paste pipeline.

Cameras will be installed at the top and bottom of the stopes near the pour point. Cameras will monitor the discharge of the paste into the stopes and display this on an operator screen at the paste backfill plant on the surface. Once the pour is completed, it is assumed that they can be reused to monitor pouring at other stopes.

#### 16.8.4 Barricades

For paste backfill, waste rock barricades will be constructed with waste rock available underground, i.e., development waste rock, and based on a top size of 300 mm. Oversize waste rock should not be used in the barricade constructed, i.e., oversized from blasting, and should be removed accordingly.

Waste rock is to be tightly filled (jammed) to the back of the drift. Equipment such a “Push Plate” can be made to facilitate proper construction of a waste rock barricade. Shotcrete is added on waste rock to cover approximately 2/3 of the exposed surface of the barricade as well as 1 metre of the back.

The waste rock barricades will be built in the draw points (access drift) of the stopes and are designed to retain the paste backfill plug. The plug pour represents the first pour in a stope and is assumed to be poured with paste backfill to 3 m above the brow of the access drift, ensuring any overbreak is sealed by the plug. Once the plug has set, it acts as a barricade for the backfilling of the remainder of the stope height. The set time of the plug is determined based on the time (days) required to achieve the design target strength with a design binder quantity, typically validated through UCS testing.

It is assumed that the amount of excess water from the paste backfill would be minimal and that the barricade would be permeable enough to drain any excess water percolating through the fill. Therefore, this design does not include additional design recommendations for drainage to prevent water accumulations behind the barricade. If the conditions at the site are such that accumulation of water behind the barricade is possible (i.e., due to groundwater or mine drainage flows), then additional steps are required by the mine to develop a drainage system behind the barricade, mitigating excess water from accumulation behind the waste rock barricade.

### 16.9 Underground High Density Sludge (“HDS”) and Slurry Tailings Disposal

During the preproduction dewatering and the initial years of operation, i.e. until the TMF becomes available, the HDS from the water treatment and all unused tailings for the production of paste backfill will be stored in the historical drifts and mine workings at the Donalda, Quemont and Horne mines.

#### 16.9.1 HDS Underground Disposal

The disposal of HDS is based on delivering the sludge, from a temporary water treatment plant located on the surface at the Horne 5 Mining Complex, to the underground workings for their storage. The quantities and rates at which the treatment sludge will need to be handled depending on the actual water quality and the rate at which the historical mines (Donalda,

Quemont and Horne) will be dewatered. There are three main pumping stages being envisaged during the preproduction dewatering. These are summarized in Table 16-32.

Table 16-32: HDS Production

Dewatering Stages	Operational Description	HDS Production Range (m <sup>3</sup> /day)		Duration (months)
<b>Stage 1</b>	Quemont and Donalda mines	344	502	5
<b>Stage 2</b>	Horne surface and Quemont mines	287		10.5
<b>Stage 3</b>	Deep Horne mine	1,982	3,852	10

At Donalda, the volumes available are composed of raises, drifts and stopes. From the digitized excavations and stopes, the process plant production historical records and with no indication that backfill was being used, the volume of voids was determined to be in the order of 401,697 m<sup>3</sup>, where 320,000 m<sup>3</sup> is estimated available for HDS storage. There is a potentially leaking hydrostatic barricade separating Donalda from Quemont isolating the Donalda mine from the other mines. The HDS will be delivered via a system of boreholes from the surface.

At Quemont, the volumes available are composed of historical drifts and empty or partly backfilled stopes. The volume of voids available to receive HDS is estimated at 510,000 m<sup>3</sup>. There will be boreholes from the surface with connections to a series of underground boreholes to fill the voids. Hydrostatic barricades built on each of the levels will isolate the Horne 5 underground operations from the areas filled with HDS.

The dewatering and rheological properties of the HDS will be greatly influenced by the chemical and physical properties of the sludge. Based on water quality samples collected to date and the proposed HDS water treatment system it has been determined that the properties of the sludge returned underground will have the following characteristics:

- The water treatment proposed will modify the typical gelatinous nature of the sludge to a material having granulated sand like texture;
- The sludge produced, based on average feed conditions and the proposed water treatment system, should have a minimum solids content of 35 wt% solid;
- The sludge at 35 wt% solids will have a measurable static and dynamic yield stress and could be pumped under laminar, plug flow conditions.

These remain general assumptions and would need to be confirmed by testing actual HDS samples produced from water collected at site. Many of the sludge generated from the treatment of acidic mine waters can be voluminous and amorphous achieving very low solids content. The



objective would be to produce a granular sludge that could be dewatered to a thickened non-segregating consistency to facilitate placement underground.

The general backfilling strategy for the voids at Donaldda is via a series of boreholes from surface. In order to cover the extent of the underground workings and maximize the volume of voids filled a series of boreholes will be drilled from six different surface locations to different depths. For Donaldda there will be no access to the underground workings. Geophysical surveys will be used to assist in confirming that the intended targets (top of the stope) have been located.

The general backfilling strategy for the voids at Quemont is level by level starting from the bottom of the mine and moving upwards. All areas of the Quemont mine that have a connection with the active areas used for the Horne 5 operation will be isolated with hydrostatic barricades. The voids and drifts will be surveyed prior to drilling the boreholes and delivering the HDS thickened slurry. Surveying the drifts will confirm available volumes and drilling target locations. Drifts will be surveyed with remotely operated drones. Surveying will occur once the drifts have been dewatered.

**16.9.1.1 HDS Thickened Tailings Water Bleed Estimates**

No samples were available to allow testing the dewatering characteristics of the HDS thickened slurry. Considering that the HDS will be dewatered to 35 wt. % solids in a thickener there is a good possibility that the material could dewater further once placed underground in a drained mine. Under flooded conditions there is the risk that the material would segregate once it leaves the borehole leading to lower final in place densities.

**Table 16-33: HDS thickened estimated water bleed**

<b>Basis: 10 tph</b>	<b>Starting Conditions (35 wt% Solids)</b>	<b>Dewatered Conditions (50 wt% Solids)</b>
Mass Solids (tph)	10.0	10.0
Mass Water (tph)	18.6	10.0
Mass Slurry (tph)	28.6	20.0
Flow Solids (m <sup>3</sup> /hr)	4.3	4.3
Flow Water (m <sup>3</sup> /hr)	18.6	10.0
Flow Slurry (m <sup>3</sup> /hr)	22.9	14.3
Change in Volume	---	8.6 m <sup>3</sup> (37.5%)

Note: Specific Gravity of HDS Solids 2.3 and Water 1.0.

### 16.9.1.2 HDS Thickened Slurry Delivery System

In order to have commonality for the pumping, pipeline and borehole systems for each of the HDS thickened slurry options, more than one distribution system will be required to be in operation for the different stages of mine dewatering and HDS generation rate. The HDS thickened slurry will be distributed in pipelines and boreholes with a 100 mm (4") diameter.

#### Friction Loss

The slurry tailings friction losses for the different sludge generation rates were estimated from other projects with the assumption that the HDS thickened slurry at 35 wt% solids will be non-segregating, will have a measurable static and dynamic yield stress and can be pumped at low velocities under laminar conditions. The estimated friction losses for the various HDS generation rates are summarized in Table 16-34.

Table 16-34: Summary of friction losses for HDS at 35 wt% (100 mm (4") system)

Dewatering Stages	HDS Production Range		HDS Distribution		HDS Velocity	Friction Loss
	(m <sup>3</sup> /day)	(m <sup>3</sup> /hr)	# of 100 mm Lines	(m <sup>3</sup> /hr / line)	(m/s)	(kPa/m)
Stage 1	344	14.33	1	14.33	0.48	0.38
	502	20.92	1	20.92	0.71	0.40
Stage 2	287	11.96	1	11.96	0.40	0.37
Stage 3	1,982	82.56	2	41.29	1.40	0.46
	3,852	160.50	3	53.50	1.81	0.49

For the sludge being disposed of underground at Donalda the sludge generated at the Water Treatment Plant will be pumped approximately 4.5 km in insulated 100 mm (4") pipelines to the six drilling stations (boreholes collars). From each of these drilling stations there will be a number of twinned boreholes that will deliver the sludge to the various underground locations within the mine. The number and length of boreholes from the different stations are listed in Table 16-35.

Table 16-35: Borehole summary for HDS thickened slurry distribution at Donalda mine

Borehole Summary for HDS Thickened Slurry Distribution at Donalda	Collar Location	Diameter (mm)	Length (m)	Number of Holes
Drilling Station 1	Surface	100	100	2
		100	70	2
		100	50	2

Borehole Summary for HDS Thickened Slurry Distribution at Donalda	Collar Location	Diameter (mm)	Length (m)	Number of Holes
Drilling Station 2	Surface	100	119	2
		100	129	2
Drilling Station 3	Surface	100	120	2
		100	77	2
		100	74	2
		100	113	2
		100	157	2
		100	104	2
		100	150	2
Drilling Station 4	Surface	100	178	2
		100	200	2
		100	176	2
		100	192	2
Drilling Station 5	Surface	100	186	2
		100	200	2
		100	160	2
		100	168	2
		100	153	2
		100	164	2
		100	167	2
		100	200	2
		100	218	2
		100	200	2
		100	215	2
		100	257	2
		100	204	2
		100	269	2
Drilling Station 6	Surface	100	332	2
		100	296	2
		100	282	2
		100	303	2
		100	364	2

For the HDS thickened sludge disposed of in the Quemont Mine, located near the Water Treatment Plant, boreholes will be drilled from five main drilling platforms to reach the extremities of each drift at Quemont. A filling and breather hole will be drilled to each drift according to where the sludge is to be delivered. The drilling platforms for borehole collars are located on the surface, Q64, Q275, and Q715. The boreholes intersect drifts that are

inaccessible and rehabilitation of the historical drifts on levels Q64, Q275 and Q715 is required for drilling access. Some sections of the levels Q64 and Q275 will be rehabilitated further from the Quemont No. 2 shaft in order to maximize the backfilling of the voids in the upper portion of this historical mine. Piping is also required on these levels to connect boreholes servicing the lower level drifts. Boreholes will be drilled at a variety of angles, a summary of the boreholes for the HDS distribution at Quemont is presented in Table 16-36.

Table 16-36: Borehole summary for HDS distribution at Quemont mine

Borehole Number	Collar Location	Toe Location (QL)	Diameter (mm)	Length (m)	Number of Holes
1	Surface	64	100	82	2
2		100	100	112	2
3		136	100	141	2
4		173	100	171	2
5		222	100	243	2
6		275	100	281	2
7	Q64	222	100	157	2
8		275	100	212	2
9		275	100	208	2
10		275	100	216	2
11	Q275	330	100	54	2
12		330	100	68	2
13		385	100	108	2
14		385	100	117	2
15		385	100	138	2
16		440	100	166	2
17		440	100	199	2
18		495	100	217	2
19		495	100	237	2
20		550	100	272	2
21		550	100	308	2
22		604	100	329	2
23		604	100	370	2
24		659	100	420	2
25	715	100	469	2	
26	Q550	715	100	20	2
27		769	100	101	2
28		815	100	143	2
29		861	100	178	2

Borehole Number	Collar Location	Toe Location (QL)	Diameter (mm)	Length (m)	Number of Holes
30		906	100	235	2
31		952	100	286	2
32		998	100	318	2
33		998	100	510	2
34		1043	100	359	2
35		1089	100	404	2
36		1180	100	507	2

### 16.9.2 Tailings Slurry Disposal

The disposal of slurry tailings is based on delivering tailings from the process plant to boreholes servicing the Horne mine. There are three possible quantities of slurry tailings available for disposal underground; full tailings streams (Option 1), the tailings slurry remaining from the process plant during full paste backfill operations (Option 2), and the tailings slurry remaining from the process plant when half of the paste backfill plant (one plant) is in operation (Option 3). Details of the slurry available for underground disposal is summarized Table 16-37. The values are based on a process plant production of 16,304 tpd.

Table 16-37: Slurry tailings production

Slurry Production Options	Operational Description	Slurry Material	Slurry Density (%)	Total Low Pressure Piping (m)		
				tpd (solids)	tph (solids)	m <sup>3</sup> /hr (slurry)
<b>Option 1</b>	Paste plant not operating (Full Tailings Streams)	63% PFT / 37% PCT	55.5	16,304	679	757
<b>Option 2</b>	2 Paste Lines Operating	100% PFT	62.0	4,239	285	172
<b>Option 3</b>	1 Paste Line Operating	71% PFT / 29% PCT	56.7	10,271	428	463

At the historical Horne mine, the volumes available are composed of old drifts, abandoned shafts (not reused for the Horne 5 operations), raises and empty or partly backfilled stopes. The volume of voids is as follows: 10.3% of the volumes available are drifts, 1.3% are abandoned shafts, 0.5% are raises, and 87.9% are stopes. The historical Horne mine extends from the HL53 (approximately 53 m from the surface) to the HL2449 (approximately 2,450 m from the surface). The 4,796,613 m<sup>3</sup> of voids were identified by InnovExplo by digitizing from the available original mine drawings. As a result, the digitized drawings are subject to location errors or omissions. Considering the system of boreholes and connections proposed to backfill Horne, it is assumed that approximately 4,022,350 m<sup>3</sup> (84%) can be backfilled with slurry or cemented paste.

The majority of the Horne mine voids are located in the upper part of the mine. Approximately 89% of the available voids are above the historical Horne level 12 (HL436). The voids available between the drifts on the historical Horne level 1 (HL53) and the drifts on the historical Horne level 12 (HL436) in the former Horne mine can be used for tailing slurry storage while the voids available between the drifts on the Horne level 13 (HL474) and the drifts on the historical Horne level 65 (HL2449) in the historical Horne mine will be used for cemented paste storage.

The general backfilling strategy is to isolate the Horne 5 Mining Complex with a plug of cemented paste backfill before discharging tailings slurry in the Horne former levels above. The backfilling of slurry will only start once levels HL474 to HL704 of the Horne mine have been filled with cemented paste backfill and the paste has cured. This plug of paste above the Horne 5 Mining Complex will extend vertically on 250 m and will require approximately 165,000 m<sup>3</sup> of paste. The remaining existing former drifts and voids between levels HL743 to HL2449 will be backfilled with cemented paste backfill during the development of the Horne 5 Mining Complex, using the paste backfill UDS and from short holes drilled on Horne 5 levels and targeting former Horne drifts positioned 5 m below.

The voids that will be filled with tailings slurry in the Horne mine will start from HL436 and will move upwards. Levels HL360 to HL436 will be backfilled with slurry from boreholes from the rehabilitated HL322 while the levels HL53 to HL322 will be backfilled with slurry from the surface once the hydrostatic barricade on level HL322 isolating the area has been constructed. The tailing slurry could be delivered via a 250 mm (10") pipeline from the process plant to the top of Horne mine, on the Third Party's property. The selected route for this pipeline would limit disturbances to adjacent surface activities (Figure 16-70). The slurry from the 250 mm (10") surface pipeline will be split in two before being delivered underground down two 150 mm (6") boreholes. Ground Penetrating Radar ("GPR") surveys will be used to assist in confirming that the intended targets have been located. The HL53, HL84 and HL115 will be the last levels to be filled with slurry tailings at Horne mine.





Figure 16-70: Proposed surface slurry pipeline on Horne property

### 16.9.2.1 Slurry Water Bleed Results and Tonnage Backfilled

One-litre slurry settling tests were performed on the PFT and PCT material and a blend of the two. The results are presented in Table 16-38. They are for unflocculated material. Considering the size of the tests it is likely that higher solids content would have been observed with larger bed depths due to compaction. These values were used to estimate the amount of tailings that can be backfilled in available volumes for slurry tailings disposal.

It is planned that the former shafts 4 and 5 of the Horne mine will be backfilled with waste rock from HL9 to HL19. The filling of the shafts with waste rock will act as a drain for the cemented paste backfill and the tailings slurry bleed water. A pumping station will be installed at the base of the column of waste rock to collect the water into the mine dewatering system. The same two shafts will also be used to monitor, from the surface, the head of bleed water built above the tailings slurry discharging levels. This head of water will be pumped to the surface facilities for management.

Table 16-38: Slurry water bleed results (wt% solids)

Sample	100% PFT 0% PCT	63% PFT 37% PCT	0% PFT 100% PCT
Starting Solids Content	62.0	55.5	47.0
After 1 hour	64.8	58.4	53.1
After 2 hours	68.1	62.6	56.7
After 12 hours	69.6	68.2	63.0
After 24 hours	70.2	70.6	66.8
Estimated Final Solids Content	75.0	77.0	77.0

### 16.9.2.2 Slurry Tailings Delivery System

In order to have commonality for the pipeline and borehole system for each slurry tailings option, more than one distribution system will be required to be in operation at one time. The slurry tailings UDS will be distributed in boreholes and pipelines with a 100 mm (4 in) diameter. The only exception is the surface slurry pipeline from the Horne process plant to fill the top levels of the Horne mine. The surface line from the process plant to the Horne mine will be 250 mm (10 in) in diameter and sent underground in two 150 mm (6") borehole lines.

#### Friction Loss

The slurry tailings friction losses for the three slurry production options were calculated using a two-layer hydraulic model based on the work of Hallbom (2008), Wasp and al. (1977, 1978), Wilson and Thomas (1985, 2006), Wilson and al. (1992) and the unit friction loss for the slurries was estimated based on the parameters presented in Table 16-39. The friction loss values are presented in Table 16-40.

Table 16-39: Summary of parameters used in determining friction loss for 100 mm (4 in) system

	63% PFT / 37% PCT	100% PFT	71% PFT / 29% PCT
Solids Specific Gravity	3.22	2.79	3.12
Solids Concentration by Weight (wt%)	55.5%	62.0%	56.7%
Slurry Tailings Specific Gravity	1.62	1.66	1.63
Operating Flowrate (solids) (tph)	679	177	428
Operating Flowrate (slurry) (m <sup>3</sup> /h)	756	172	463
Number of Operating Boreholes	3	1	2
Operating Flowrate per borehole/pipeline (slurry) (m <sup>3</sup> /h)	252	172	232



**Table 16-40: Summary of friction losses for slurry tailings options (100 mm (4 in) system)**

	63% PFT / 37% PCT	100% PFT	71% PFT / 29% PCT
Nominal Borehole Size (mm (inch))	100 (4)	100 (4)	100 (4)
Slurry Velocity (m/s)	8.6	5.9	8.0
Friction Loss (kPa/m)	14.2	7.6	12.1

The target velocity of slurry travelling in pipelines and boreholes is typically based on a speed greater than its settling velocity, while reducing the maximum velocity concurrently to decrease and minimize wear in the lines. In this case, the UDS has a very short life span so greater velocities are acceptable. Also, the higher velocities allow the use of smaller boreholes and pipelines, reducing the cost of drilling and materials.

### 16.9.2.3 Horne Mine Delivery System

To access and backfill the drifts in the upper part of Horne mine, a 3,5 km long pipeline is proposed to be built from the process plant to three drilling platforms located on the Third Party's property. A filling and breather hole should be drilled to each drift according to which slurry tailings are delivered. A drilling platform for borehole collars could be located on HL32. The drilling platform would be located on a level that is inaccessible; thus, rehabilitation of the old drift on HL322 is required for drilling access and to run piping for slurry distribution

Boreholes should be drilled at a variety of angles for the slurry distribution and a summary of the boreholes for the Slurry Tailings distribution at Horne is presented in Table 16-41.

**Table 16-41: Borehole summary for slurry tailings distribution at Horne mine**

Borehole	Collar Location	Toe Location (HL)	Diameter (mm)	Length (m)	Number of Holes
1-1	Surface	53	150	43	2
1-2		53	150	40	2
2-1		84	150	70	2
2-2		84	150	74	2
3-1		115	150	99	2
3-2		115	150	104	2
3-3		115	150	102	2
4-1		146	150	135	2
4-2		146	150	134	2

Borehole	Collar Location	Toe Location (HL)	Diameter (mm)	Length (m)	Number of Holes
4-3		146	150	132	2
4-4		146	150	131	2
5-1		176	150	161	2
5-2		176	150	161	2
5-3		176	150	175	2
5-4		176	150	164	2
6-1		208	150	194	2
6-2		208	150	197	2
6-3		208	150	246	2
7-1		244	150	230	2
7-2		244	150	230	2
7-3		244	150	237	2
7-4		244	150	230	2
8-1		284	150	269	2
8-1		284	150	269	2
9-1		322	150	309	2
9-2		322	150	307	2
9-3		322	150	308	2
9-4		322	150	309	2
9-5		322	150	309	2
9-6		322	150	308	2
10-1		360	150	347	2
10-2		L322 (HL9)	360	100	89
11	398		100	113	2
12	436		100	136	2
13	436		100	163	2
14	474		100	214	2
15	552		100	240	2
16	585		100	289	2
17	627	100	307	2	

## Flow Modelling

Flow modelling was performed to confirm the hydraulic design of the borehole system at Horne. The flow model balances the hydraulic head available with the friction losses present in the boreholes and pipelines. The pipeline borehole routing for each delivery option to the Horne drifts was inserted into the flow model to determine the pressures in the system. The slurry tailings will be pumped into the old mine drifts at Horne. The model was also run for all three slurry tailings production options because each slurry option has different operating parameters.

In general, the slurry tailings system for Horne is designed to be distributed by centrifugal pumps. The underground pipelines consist of 100 mm (4 in) diameter high pressure, carbon steel schedule 80 (ASTM A53 Gr. B) piping with Victaulic Style 77 couplings. During operations, there will be significant operator control in determining which areas will be filled, based on the slurry tailings material available. Filling of Horne with slurry tailings will start with the bottom level (HL474L), working upwards until the maximum amount of slurry tailings fills is distributed to the drifts and old mine workings at Horne Mine.

### 16.9.3 Quemont and Horne Barricades

Barricades are required on all levels connecting with areas of the Quemont mine that are to be in operation or where drifts connect to the Quemont No. 2 Shaft. There will also be one barricade located on HL322.

#### 16.9.3.1 Design Criteria

The barricades shall be designed in a 'failsafe' mode where design criteria are as follows:

- If there is a failure in the barricade due to poor construction, ground movement, rock failure, leakage or other possible failure mechanisms, then the resulting flow of water or slurry will not be in excess of the capacity of the mine dewatering system to accommodate it;
- The barricades shall be designed for operation with a minimal requirement for operator monitoring and/or intervention. In other words, the barricades will not require an operator or automated systems to operate correctly to ensure proper functioning.
- Pressures generated at the lowest barricade could potentially include the entire hydraulic head that could be generated by the deposited slurry.
- It is assumed that the entire deposited slurry could be mobilized by a seismic event causing liquefaction;
- It is assumed that there are enough connections between levels (via drill holes, raises, stopes, etc.) that the full hydraulic head can be developed between levels;

- The Quemont mine depth includes a maximum of approximately 1,200 m of potential slurry head;
- The specific gravity of the slurry is expected to be 1.6;
- It should be noted that the current mine plans indicate that the bottom 400 m of the Quemont mine could be isolated from the rest of the mine since there appear to be no stopes connecting the bottom 400 m of the mine with the top 800 m of the mine. If this is the case, there is the possibility of isolating the bottom 400 m so that the maximum pressure acting on the worst case bulkhead is 800 m of slurry head. This will be validated during new mine surveys.

The length of barricade will be categorized based on the drift sizes and head of slurry. All drifts (Quemont and Horne) are assumed to be 2.4 m (width) by 2.4 m (height) with very rough surfaces.

Barricades will not be placed at a curved section in the drift; they should be straight in plan and elevation with no eccentricity of more than 10% in any direction.

#### 16.9.3.2 Barricade Design

The barricades will be designed and constructed according to the design criteria and the individual locations in the mine in which they are placed.

Barricades will be composed of a long concrete plug with a rebar grid at the downstream end of the barricade.

The barricade design relies on mass concrete rather than extensive rebar and doweling. No dowels are required into the rock and the only rebar required is a single mat on the downstream end of the barricade.

Drainage pipes will be installed through the barricade and will be covered by a sand filter. The drainage pipe will allow a means of egress for any bottom drain water exiting the consolidating slurry. The drainage pipe will be equipped with an automated isolation valve, manual isolation valve, conductivity sensor and a pressure transmitter.

The dominant mode of failure for the barricade is shearing along the rock/concrete interface. The barricades will be designed using deep beam theory and will take advantage of the compressive force on the face of the barricade in order to increase the shear resistance of the concrete.

Barricade installation will include the following:

- The drift will be rehabilitated for a minimum distance of 10 m from the shaft plus the length of the barricade plus an additional 20 m upstream of the barricade. Additional

rehabilitation may be required based on the final location of each barricade. Location of barricades will vary based on placement around existing infrastructure (i.e., vent raises, ore passes, etc.) and the required rehabilitation will be evaluated on a level by level basis;

- Rock will be inspected and confirmed to be in accordance with the minimum requirements for the barricade anchoring;
- Shotcrete will be applied to all the reconditioned areas;
- A camera will be installed on the upstream side of the barricade (to observe that the filling of the barricade is complete);
- Drainage pipes with sand filters will be installed to allow drainage through the barricade;
- A 200 mm shotcrete wall will be constructed on the upstream and downstream side of the barricade to serve as a form for the main concrete pour. The downstream shotcrete wall will incorporate the rebar mat (30 mm diameter rebar at 250 mm spacing each way).

Concrete will be poured continuously to fill the barricade void. Pouring will stop when discharge is observed from the overflow pipe. The last concrete pouring stage should have expanded cement to prevent any shrinkage and having connection to the back (top surface) of the drift.

The typical design of the barricade for Quemont and Horne is shown in Figure 16-71. The barricade length varies by plug location and is based on the depth below surface. In general, the deeper the plug location, the higher the potential slurry head and, therefore, the longer the plug design.

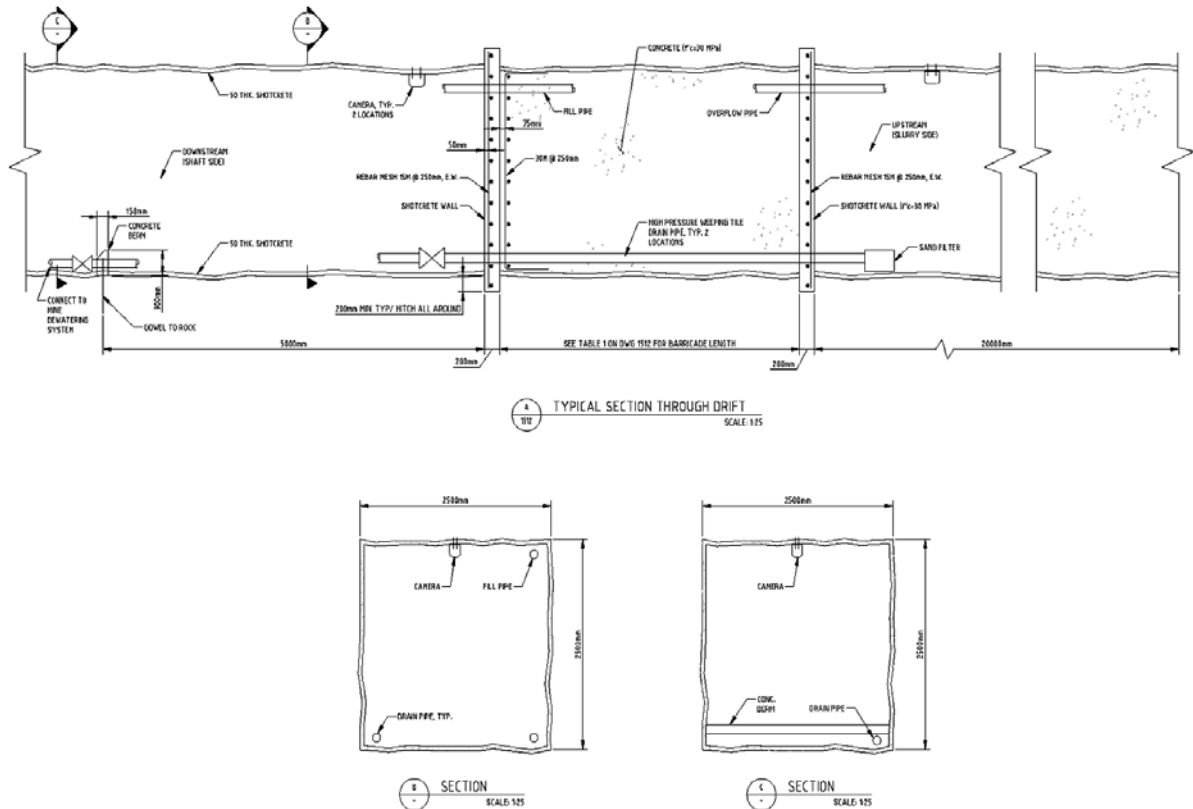

Figure 16-71: Typical plug design for Quemont and Horne mines

### 16.9.3.3 Barricade Materials Delivery and Placement

The materials required to erect the barricades at Quemont and the one at Horne will be delivered as follows:

- Concrete will be delivered down 200 mm slurry delivery holes or a slick line into a receiving tank at each barricade level;
- Concrete will be pumped into the barricade using a diesel concrete pump located on the barricade level;
- Rebar will be delivered down the shaft via the cage;
- The shotcrete wall formwork will be delivered down the shaft via the cage;
- Shotcrete will be delivered down the shaft in bulk bags and applied with a dry mix applicator;

- Water will be supplied from the shaft station on the level for hosing, shotcrete and concrete cleanup, etc.;
- Compressed air will be supplied by an electrical compressor in the station for any equipment that requires compressed air;
- Power will be delivered via the shaft station (600 V and 120 V).

#### 16.9.3.4 Dewatering

##### During Construction (Preproduction)

It is anticipated that due to the grade of the drift towards the shafts, some water could be present in the drift. Water flowing during shotcreting or concrete placement will damage the integrity of the concrete or shotcrete and must be prevented.

During the initial rehabilitation phase, the water inflow will be assessed, and if required, a shotcrete berm will be placed to prevent water from flowing through the areas to be shotcreted. If the water filling rate is too high for the berm to accommodate between the time it is placed and the completion of the shotcrete wall then a dewatering pump will be required to pump water from the upstream side of the berm to the shaft station discharge.

##### During Production

Once the barricade is constructed it is likely that there will be water discharging from the barricade or the surrounding rock via fractures and cracks. This water discharging from the barricade will be collected in the discharge pipe. The discharge pipe will be connected to a pipeline in the shaft Quemont No. 2, where it will drain into the mine dewatering sumps. Any water discharging from the surrounding rock mass will be monitored and collected in a bermed area in front of the barricade and allowed to drain into the mine dewatering system. Based on the volume of water discharging from the surrounding rock mass, grouting of the surrounding rock mass may be required.

#### 16.9.3.5 Monitoring

Although the barricade has been designed so that it does not need to be monitored at all times, there are some monitoring capabilities that have been designed into the system to allow the operators to assess the status of the barricades remotely:

Pressure transmitters will provide local and remote indication of the pressure behind the barricade.

- An embedded pressure plate style transmitter will be embedded behind the barricade wall to measure pressures in the slurry mass;

- A diaphragm style pressure transmitter will be mounted on the drain line to measure pressures at the drain discharge;
- The differential between the two will be measured, to determine whether the drain is effectively allowing drainage or whether it is plugged, by closing the drain isolation valve and comparing the two pressure transmitter values;
- A high level for either of the two pressure transmitters will alarm the operator.

A level transmitter in the bermed area will measure an excess of flow through the bulkhead which will indicate a major leak exceeding the ability of the dewatering system to handle the flowrate. A high level will alarm the operator.

A flowmeter in the dewatering pipe through the barricade will measure the flowrate. A high flowrate will alarm the operator.

A conductivity sensor in the dewatering pipe will measure the conductivity of the water. A change in conductivity will alarm the operator of a change in water chemistry and possible change conditions behind the barricade.

An electronically operated ball valve will be located on the dewatering pipe and will be operated from the surface.

A camera will be located at the barricade area enabling the operator to visually observe the barricade, flowrate of any water exiting the surrounding rock mass, and the level of water behind the berm.

#### 16.9.3.6 Barricade Locations

It is estimated that a total of 37 barricades will be required for Quemont to prevent slurry tailings from entering the No. 2 shaft. A summary of the number of barricades and the length of the plugs for the Quemont mine is shown in Table 16-42.



Table 16-42: Barricade summary for slurry tailings distribution at Quemont mine

Quemont Level (Q)	Plug Length (m)	Number of Barricades	Remarks
Q64	2	3	Connection to Horne 5 (L115)
Q100	2	2	
Q136	2	2	
Q173	2	2	
Q222	5	1	
Q275	5	2	Connection to Horne 5 (L322) and drilling platform
Q330	5	2	
Q385	5	2	
Q440	8	2	
Q495	8	2	
Q550	8	1	
Q604	8	2	
Q659	10	1	Connection to Horne 5 (L743) and drilling platform
Q715	10	2	
Q769	10	1	
Q815	10	1	
Q861	12	1	
Q906	12	1	
Q952	12	1	
Q998	12	2	
Q1043	12	1	
Q1089	15	1	
Q1180	15	1	Connection to Horne 5 (L1194)

#### 16.9.4 Self-heating

Self-heating is a phenomenon of oxidation of sulphides conducting to an elevation of the temperature and the emission of sulphur dioxide (“SO<sub>2</sub>”). Considering the content in sulphide for the backfill used to fill empty stopes at both the Quemont and Horne mines during their operation (e.g. Hall,1937) as well as the content in sulphide for the cemented paste backfill and the slurry backfill, self-heating, although not certain, can be expected with all of these types of backfill.

In addition to the current plan, which is maximizing the backfilling of the underground voids in former Horne mine in order to limit the ingress of air, SO<sub>2</sub> monitoring is the only preventive measure being recommended as this time. The monitoring will begin during the dewatering phase and continue during the preproduction and early mining phase of the Project until the voids in the inactive mines have been filled.

### 16.9.5 Remote Plugs

Hydrostatic plugs exist between historical mines that have underground connections. Three hydrostatic plugs were identified in the PEA.

- Quemont/Horne Plug: Between Horne mine L3 and Quemont mine L200;
- Joliet Plug: Between Horne mine L9 and Joliet mine;
- Donalda Plug: Between Quemont mine level Q1260 and Donalda mine.

The condition of these plugs is not known and may become unstable during the dewatering process.

During the various phases of preproduction dewatering, four remotely constructed hydrostatic plugs will be required. The plugs will be designed for a maximum head pressure at their location. The purpose of building new plugs is to isolate the various mines during different stages of dewatering. Initially, the Donalda mine needs to be isolated from Quemont mine and Quemont mine from Horne mine. Later on, the Horne mine needs to be isolated from both the Joliet and Chadbourne mines. Regardless of when the plugs are required, they will all be built sub-aqueously because the plug locations will not be accessible from underground locations and to ensure personnel safety. The details of the mine dewatering are located in Section 16.4.

All of the remote plugs will be constructed from boreholes at surface locations. Both the placement and mix designs are based on submerged construction. Since all the remote hydrostatic plugs will be constructed sub-aqueously and without underground access during the entire life of mine, contact between the plug and bedrock will be minimal. For this reason, after the construction, the concrete delivery holes will be re-drilled through the plug and into the floor in order to grout the area.

## 16.10 Underground Mine Equipment

### 16.10.1 Working Hours and Equipment Performance Table

The working schedule for the production and development crews is two shifts per day, at 10 h/shift, 365 d/year. As the Horne 5 Project will be a highly mechanized and efficient operation, an 85% average availability rate and 80% average utilization rate was assumed for the majority of the equipment selection. These averages are based on industry standards and reflect the expected operating hours.

Excavating will be automated using a tele-operated system that will allow for production technicians to control multiple equipment simultaneously (hoist, production LHDs, rockbreakers, hammers, etc.) from the control room. This will increase equipment operation hours by eliminating the time required for re-entry after blasting, lunch breaks and the time to access the working area by personnel.

Table 16-43: Equipment performance

	Mechanical availability (%)	Utilization rate (%)	Efficiency rate (%)	Total operational efficiency (%)	Operating hours per shift	Operating hours per year	Motor hours per year
LHD 14 yd	85	85	87	63	7.58	5,533	5,000
Truck 50 tonnes (production)	85	73	86	53	5.31	3,878	3,500
Production drill	80	75	80	48	4.79	3,500	3,500
Cable drill and bolter	80	75	80	48	4.79	3,500	3,500
LHD 11 yd	85	75	87	55	5.53	4,033	3,000
Truck 50 tonnes (development)	85	75	87	55	5.53	4,033	3,000
Jumbo drill	80	61	84	41	4.10	2,995	3,000
Bolting Machine	80	75	87	52	5.20	3,796	3,000
Scissor lift	85	75	87	55	5.53	4,033	2,000
Anfo Loader	85	75	87	55	5.53	4,033	2,000
Scissor lift u/g - Construction	85	75	87	55	5.53	4,033	2,000

## 16.10.2 Production Requirements

The type and amount of drilling equipment was determined based on the selected optimal drilling parameters of 165 mm (6.5 in) diameter holes with 4.5 m spacing per 5.0 m burden pattern. Using a productivity of 126 m/d per drill that considers availability, efficiency and utilization, it was estimated that five drills (Sandvik DU412i or equivalent) would be sufficient to maintain the approximate 15,500 tpd LOM average production target (including spare equipment).

For the development equipment (jumbos, LHDs, trucks and bolting machines), the quantities were based on the number of development crews working on each of the phases. A maximum of four development mining crews per shift will be active during the production phase over the life of the mine. One development LHD will be matched with one 50 t truck.

For the production equipment, Sandvik LH621 LHDs have been selected for their high production capacity. It was calculated that 3.4 LHDs would be needed to achieve the approximate 15,500 tpd LOM average production rate using following performance rate :

- 85% utilization rate (since they will be tele-operated as discussed in the previous section);
- 87% efficiency rate;
- 85% mechanical availability.

This number has been rounded to four LHDs and a spare has been added for a total of five.

Fifty-tonne production trucks will be used for the bottom part of the mine that does not have access to the orepass network. One truck will be needed to achieve the Phase 2 production rate in that area.

## 16.10.3 Mine Equipment List

This study is based on new equipment that will be acquired for the Horne 5 Project. The development equipment will be purchased for the start of mine production, as the same equipment will also be required for Phase 2. Equipment provided by the mining contractor will be used in the preproduction period. A total of 77 units of mobile equipment will be required for the project as listed in Table 16-44.

Table 16-44: Mining equipment for the Horne 5 Project

Equipment list	Preproduction	Production	
		Phase 1	Phase 2
<b>Production</b>			
LHD 14 yd (automated)	3	5	5
Truck 50-tonne	0	0	1
Production drill (automated)	3	5	5
Cable drill and bolter (one hole automated)	1	2	2
Explosive truck	1	2	2
Scissor lift - Paste backfill piping	1	1	1
Tractor u/g - Paste backfill	1	1	1
<b>Development</b>			
LHD 11 yd	0	4	4
Truck 50-tonne	0	4	4
Jumbo drill (two boom automated)	0	5	5
Bolting Machine	0	5	5
Scissor lift	0	2	2
Anfo Loader	0	2	2
<b>Services</b>			
Scissor lift u/g - Construction	3	3	3
Tractor u/g - Mechanical	2	4	4
Tractor u/g - Electrical	1	2	2
Tractor u/g - Technical	2	4	4
Pickup u/g	3	8	8
Water truck	1	1	1
Fuel truck	1	2	2
Shotcrete machine (dry)	2	2	2
Getman A64 crane	2	2	2
Concrete Truck	2	2	2
16 Passengers carrier	2	3	3
Boom truck U/G	2	2	2
Grader	1	1	1
Lift u/g	1	1	1
Scoop - service and construction	1	1	1
<b>Total</b>	<b>36</b>	<b>76</b>	<b>77</b>

## 16.11 Mine Personnel

The mine will operate seven days per week, night and day (24/7). This schedule is equivalent to 365 days per year of operation.

- Development and production crews will be on a schedule of 5 days working / 4 days off, for 10 h/shift, night and day;
- Production technician crews will be on a schedule of 5 days working / 4 days off, for 12 h/shift, night and day;
- The maintenance crew will be on a schedule of 5 working days / 4 days off, for 10 h/shift, night and day or days only.

Table 16-45 lists the mine staff requirements on a schedule of 5 working days / 2 days off, for 8 h/shift days only.

Table 16-46 lists the hourly manpower requirements on various schedules.

**Table 16-45: Mine staff requirements – maintenance services and operations**

Department manpower	Manpower
<b>U/G maintenance department</b>	
<b>Mechanical department</b>	<b>12</b>
Maintenance superintendent	1
Surface supervisor	1
Fixed equipment supervisor	1
Mechanical supervisor	4
Mechanical planner supervisor	1
Mechanical planner	3
Reliability technician	1
<b>Electrical department</b>	<b>8</b>
Assistant maintenance superintendent	1
Electrical supervisor	3
Instrumentation technician	4
<b>TOTAL U/G maintenance department manpower</b>	<b>20</b>
<b>U/G department</b>	
Mine superintendent	1
Mine captain	3
Supervisors	16

Department manpower	Manpower
Production technician	16
Mine trainer	1
<b>Total U/G department manpower</b>	<b>37</b>
<b>TOTAL Department manpower</b>	<b>57</b>

Table 16-46: Hourly manpower requirements

Hourly manpower	Manpower	Schedules
<b>U/G maintenance and services</b>		
<b>Mechanical Department</b>	<b>70</b>	
Mobile senior mechanic	20	5/4 Day & Night
Mobile feed mechanic	8	5/4 Day & Night
Mobile electro mechanic	8	5/4 Day & Night
Mobile fuel & lube attendant	8	5/4 Day & Night
Mobile junior mechanic	8	5/4 Day & Night
Mobile welder	4	5/4 Day & Night
Stationary mechanic – surface	4	5/2 Day
Stationary mechanic – U/G (5/2 shift)	4	5/2 Day
Stationary mechanic – U/G (5/4day shift)	2	5/4 Day
Stationary welder	2	5/2 Day
Loader operator	2	5/4 Day
<b>Electrical Department</b>	<b>14</b>	
Electrician (5/4day shift)	4	5/4 Day
Electrician (5/2 shift)	2	5/4 Day & Night
Automation / Communications specialist	8	5/4 Day
<b>U/G Services Department</b>	<b>56</b>	
Paste backfill service	16	5/4 Day & Night
Tailing disposal service	8	5/4 Day & Night
Support service	12	5/4 Day & Night
Grader operator	4	5/4 Day & Night
Cagetender	8	5/4 Day & Night
Deckmen	4	5/4 Day & Night
Crusher/Hammer operator	4	5/4 Day & Night
<b>TOTAL U/G maintenance and services hourly manpower</b>	<b>140</b>	

Hourly manpower	Manpower	Schedules
<b>U/G mine construction, operation and development</b>		
<b>Construction</b>	<b>32</b>	
Construction miner (CAPEX)	16	5/4 Day & Night
Construction miner (OPEX)	8	5/4 Day
Shotcrete construction	8	5/4 Day
<b>Development</b>	<b>64</b>	
Jumbo operator	16	5/4 Day & Night
Bolter operator	16	5/4 Day & Night
Development service	32	5/4 Day & Night
<b>Production</b>	<b>40</b>	
Production drill operator	16	5/4 Day & Night
Blaster	16	5/4 Day & Night
Cable drill operator	8	5/4 Day & Night
<b>TOTAL Mine construction, operation and development hourly manpower</b>	<b>136</b>	
<b>TOTAL Hourly manpower</b>	<b>276</b>	

A total of 333 employees for the underground activities will be needed during the production phases. Once the surface TMF is in operation the total employee requirements will decrease to 325.



## 17. RECOVERY METHODS

The recovery methods retained for the Horne 5 Project were established on the basis of laboratory-scale testwork performed at SGS Lakefield laboratory on 18 composites prepared from drill core sections, as described in Chapter 13. The retained flowsheet, as described in this chapter, reflects the results of this testwork and forms the basis for the plant design and plant capital and operating costs development.

The presence of cyanide-consuming base metals in the ore stream led to the adoption of a flowsheet featuring three flotation circuits upfront, in order to minimize cyanide consumption and maximize overall gold recovery. The first two flotation circuits recover, selectively and sequentially, the copper and zinc values present and upgrade them into saleable concentrates. The tailings from the zinc flotation circuit are then floated in the third flotation circuit to recover a pyrite rougher concentrate. Testwork indicated that this product would require a fine regrinding step in order to optimally yield its gold and silver content to cyanide leaching. The testwork further demonstrated that the residual precious metal values reporting to the pyrite flotation tails could be leached to provide further recovery, without regrinding.

The process plant's major areas consist of the following:

- Ore reclaiming;
- Grinding;
- Differential flotation of copper, zinc and pyrite;
- Base metal concentrates dewatering;
- Fine regrinding of the pyrite concentrate: gold leaching from pyrite concentrate and flotation tails, followed by their respective CIP and cyanide destruction circuits;
- Gold elution and refinery;
- Paste backfill preparation with a mixture of PCTs and PFTs;
- Reagent preparation circuits;
- Process and fresh water, as well as low-pressure and compressed air distribution systems.

All these areas are geared to produce copper and zinc concentrates and gold doré for delivery to buyers.

The copper concentrate is to be delivered by trucks while the zinc product is to be loaded onto railcars. The addition of a rail spur to the mine site also allows for the option to receive the additives used for paste backfill preparation by rail.

Schematic process diagrams representing the unit operations of this facility are presented in Figure 17-1 for the concentrator and Figure 17-2 for the gold recovery. Figure 17-3 displays an overall view of the process plant layout, extracted from the 3D model.

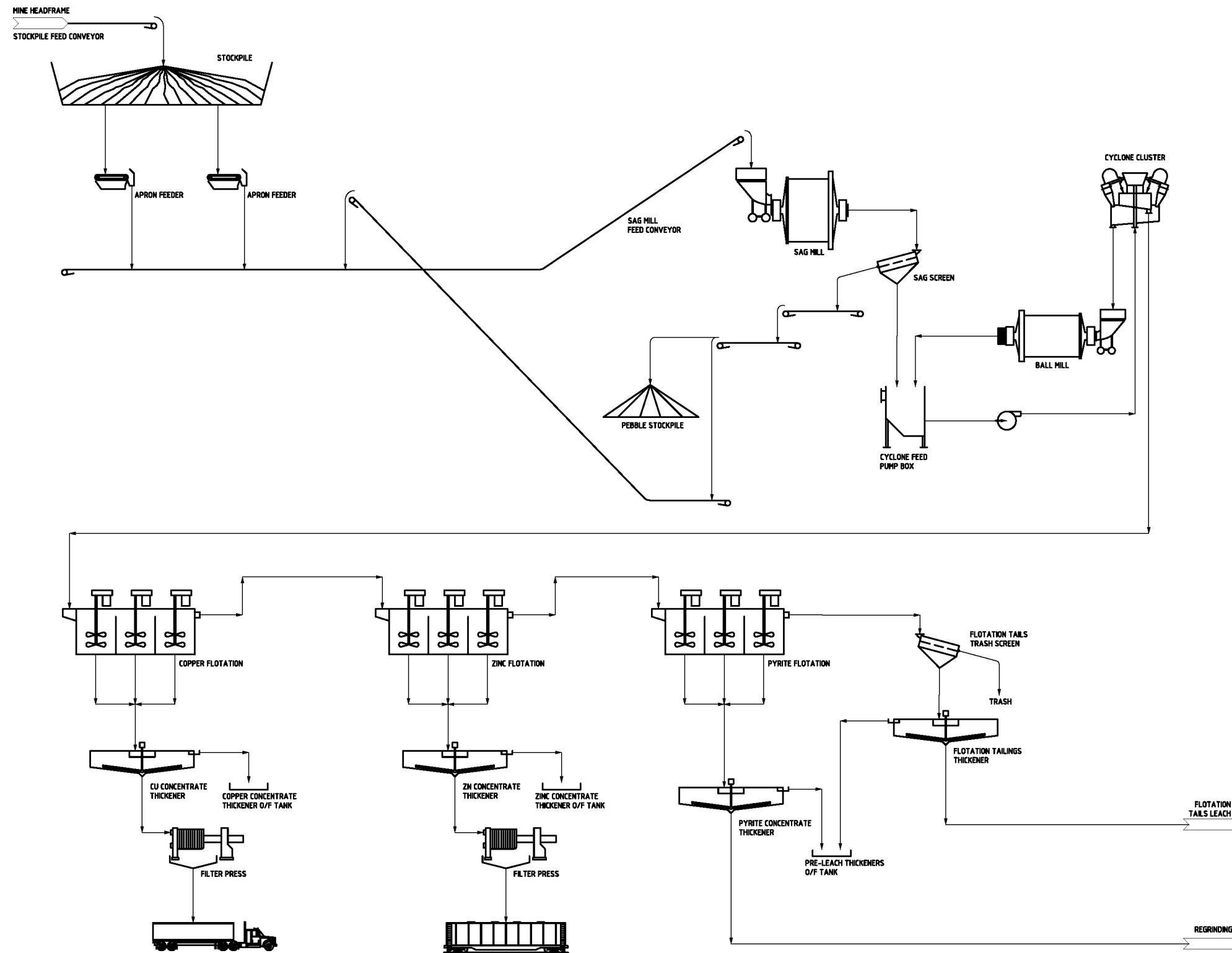

Figure 17-1: Schematic process diagram – concentrator

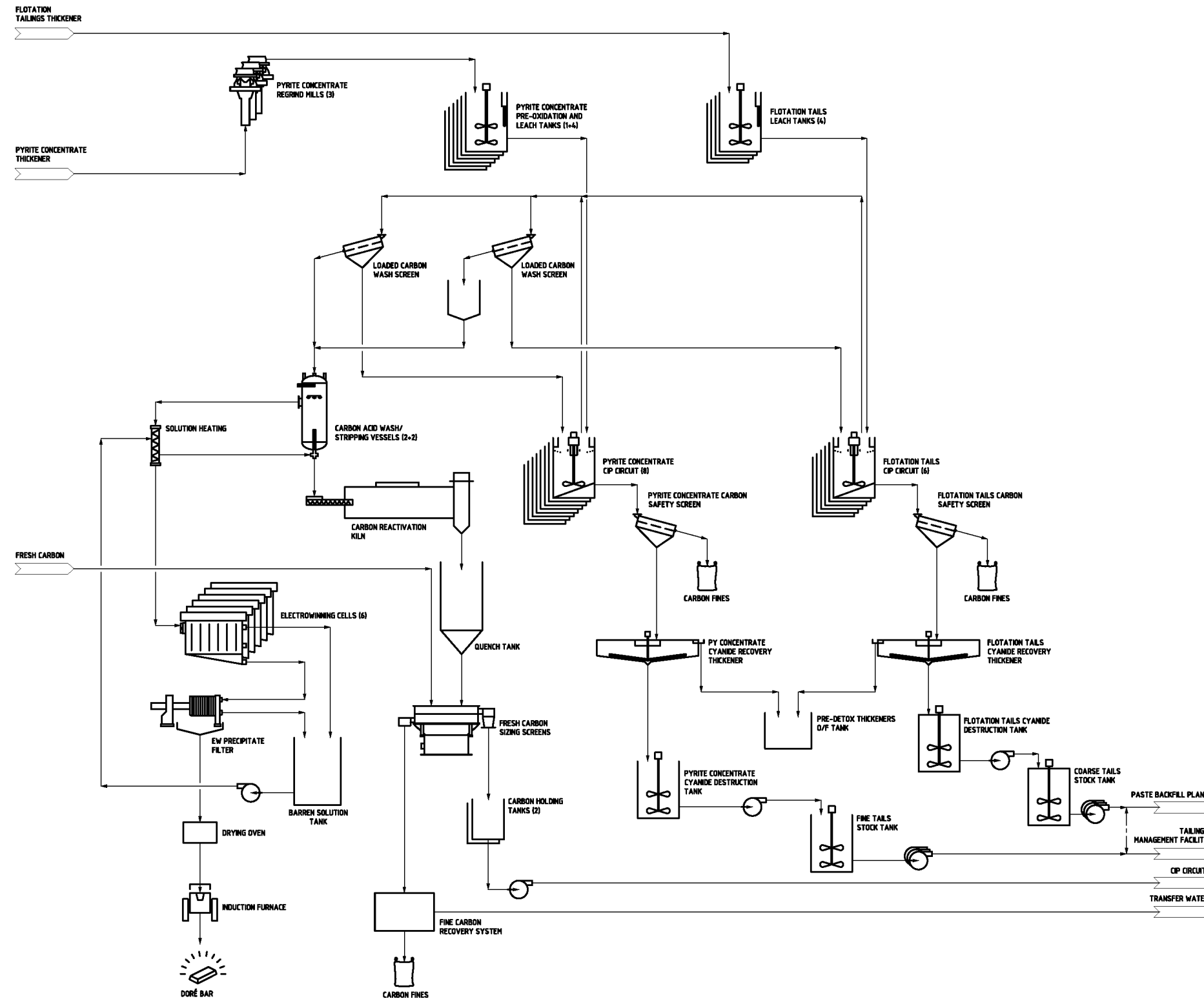

Figure 17-2: Schematic process diagram – gold recovery circuits



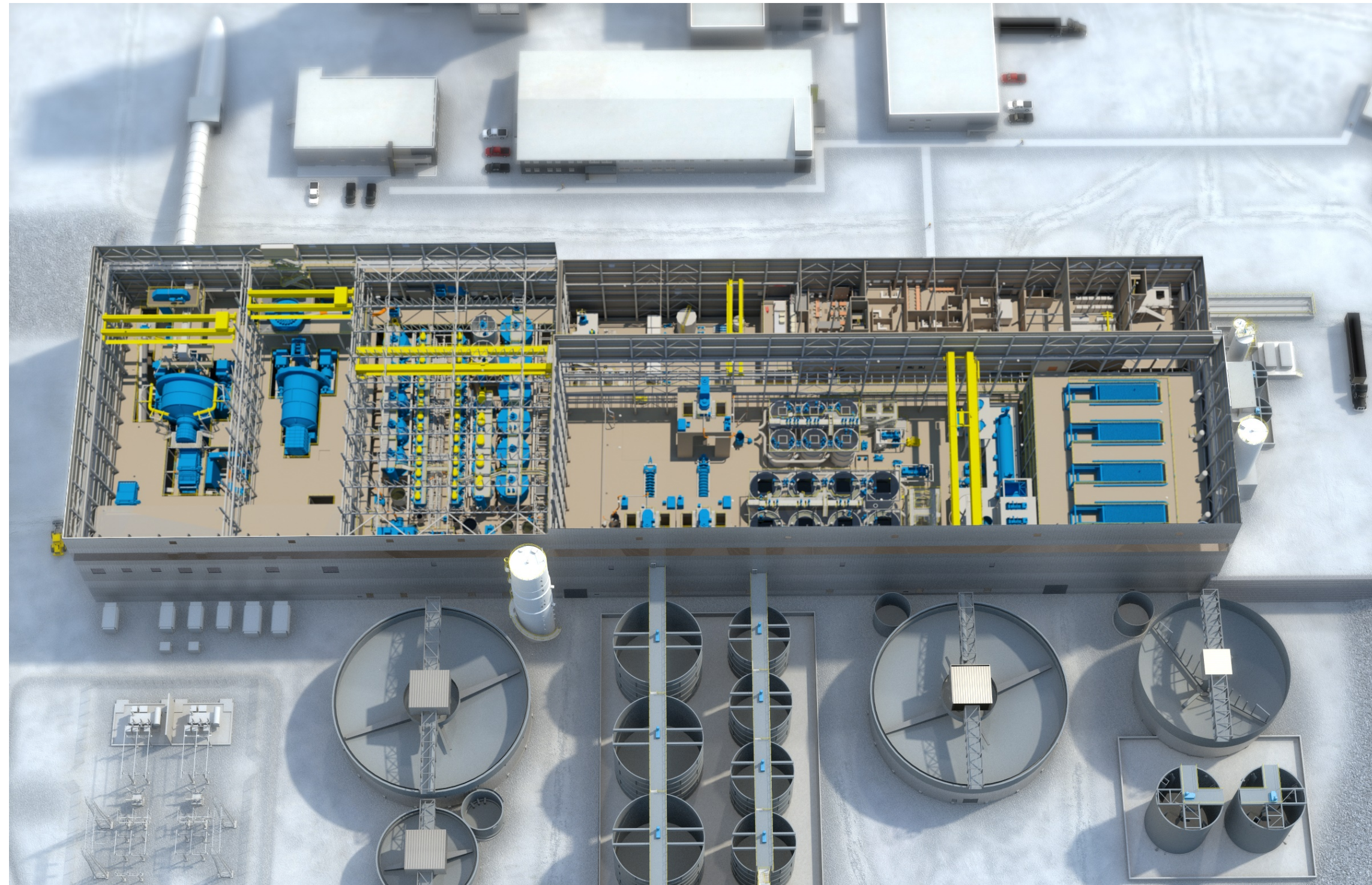

Figure 17-3: Process plant layout from 3D model



## 17.1 Processing Plant Design Criteria

### 17.1.1 Throughput Capability per Area

The design criteria to determine the sizing of the equipment are based on a nominal processing plant throughput capability of 15,000 tpd, with a 92% availability factor. This equates to an hourly throughput of 679 dry tonnes.

Peak tonnages of 115% are typically considered for most areas where flowrates are not affected by feed grades of the ore processed. These are limited to the ore reclaim, grinding, and rougher flotation circuits. Elsewhere, the grades of either copper or zinc (namely in the copper and zinc flotation cleaning circuits and concentrate dewatering circuits) or that of sulphur (in the pre-leach and pre-detoxification thickening, pyrite concentrate regrinding, pyrite concentrate and tails leaching and CIP circuits, and detoxification circuits) have an overriding influence in the determination of design flows.

At the selected design feed grades, these circuits are to be operated at the nominal plant throughput, not to unduly oversize major equipment to cover infrequent high-grade occurrences.

This flexibility will be used during the early years of the mine life, when the shallower distances travelled by the ore skips will enable to sustain a higher milling rate. The plant is thus slated to operate at a nominal 16,000 tpd during the first five years of production, following the commissioning and initial ramp-up period.

### 17.1.2 Design Feed Grades

The mine plan considered was provided by Falco in February 2017 and involved 92.8 Mt of mined resources at an average sulphur content of 16.3%

The design grades for copper, zinc, gold and silver were established by considering the peak yearly average grades from the mine plan and multiplying these values by 125%. The copper and zinc design feed grades apply to the sizing of the respective flotation cleaning circuits and concentrate dewatering circuits. Gold and silver design grades dictate the sizing of the elution circuit.

The sulphur content is much more critical since driving the sizing of the grinding mills and the split of tonnage to the individual leach, CIP and cyanide destruction circuits, as applicable to the pyrite concentrate and pyrite flotation tails. For this element, the design feed grade was established by analyzing the cumulative tonnage vs. grade distribution of the individual stopes implicated in the mine plan, both on a yearly basis and for the whole LOM. The resulting statistical analysis of the data is presented in Figure 17-4. It is noted that the development ore included in the mine plan had no sulphur grades assigned and was thus excluded from the statistical analysis. The total tonnage fraction represented by this material in the LOM plan is 3.7%.

The distribution reflects the bin and cumulative frequency of mined stope tonnage against indicated metal content. For lack of direct sulphur assays in the historical drill hole database, approximate values were derived by InnovExplo by converting the measured core SG into a sulphur content via a regression equation devised by Noranda, where all the heavy portion of the ore is attributed to the presence of pyrite (SG of 4.8-5.0) and the light fraction brought by rhyolite (SG of 2.7). This approximation is generally valid since the total sulphur content carried by both the chalcopyrite and sphalerite is typically marginal relative to that from the pyrite content. A bias is expected though where magnetite ( $Fe_3O_4$ ) is present in the material (SG of 5.17), as this mineral increases the resulting core SG without contributing to any additional sulphur content.

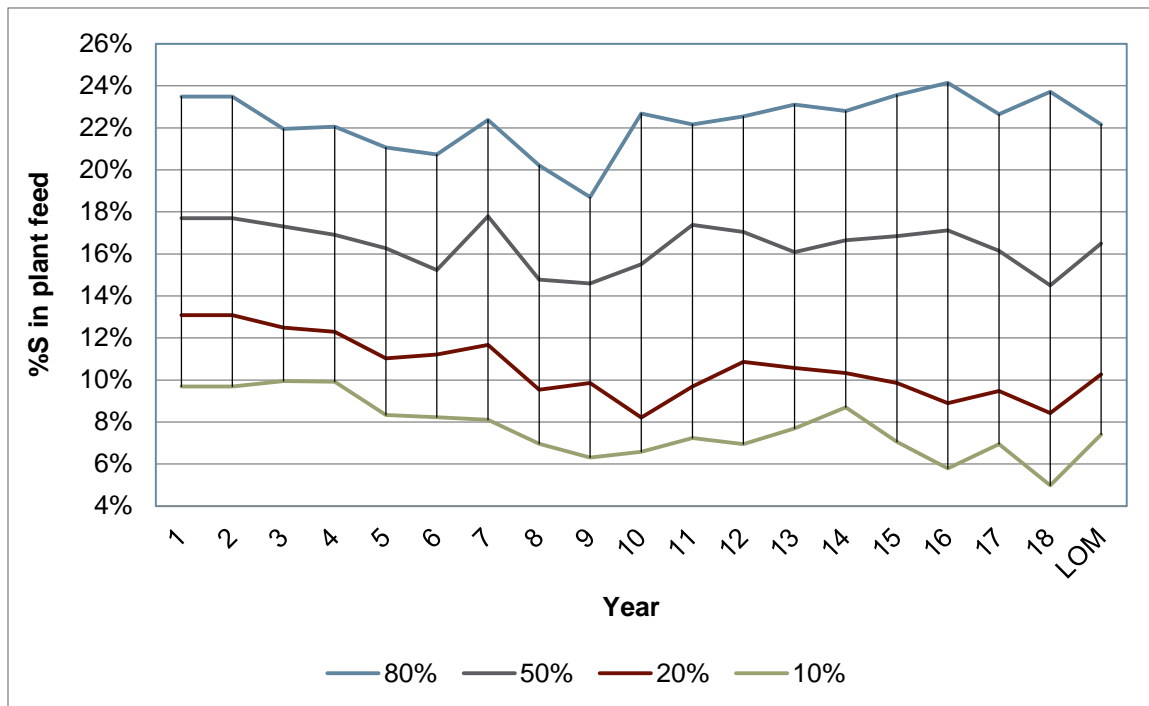

Figure 17-4: Yearly sulphur content (percentile distribution)

For design purpose, consideration is usually given to the 80<sup>th</sup> percentile. For the Horne 5, such definition is only appropriate for establishing the design criteria related to the maximum production of pyrite flotation concentrate though. Another “design” sulphur content representing the 20<sup>th</sup> percentile is also required because of the inverse correlation of sulphur content to ore hardness unearthed from the comminution testwork. This parameter is thus used to size the grinding mills and any downstream circuits called upon to deal with a maximum pyrite flotation tailings production scenario. As per Figure 17-4, the selected design sulphur content for maximum pyrite concentrate production is set at 23% S while that for the grinding mills sizing and maximum pyrite tails production is 10% S.

Table 17-1 presents an overview of the main processing plant design criteria employed. The resulting major equipment sizing parameters were thus either derived from testwork data, mine plan, benchmarked values, to meet specific Client's requirements, or a combination thereof. The mass balance data is then used to integrate the design grades and ore hardness effect, as is revealed in the following sections.

**Table 17-1: Proces plant selected design criteria**

Parameter	Units	Values				
		Cu: 0.158%	Zn: 0.739%	S: 16.31%	Au: 1.34g/t	Ag: 13.4g/t
Average feed grades <sup>(1)</sup>	%, g/t	Cu: 0.158%	Zn: 0.739%	S: 16.31%	Au: 1.34g/t	Ag: 13.4g/t
Primary grind to flotation, P <sub>80</sub>	µm	50-60				
Grinding power installed, at pinion	kWh/t	SAG mill	18.7	Ball mill	18.7	
Grinding power required, at pinion (design ore) <sup>(3)</sup>	kWh/t	SAG mill	12.5	Ball mill	16.9	
Grinding power required, at pinion (average ore) <sup>(3)</sup>	kWh/t	SAG mill	11.3	Ball mill	16.2	
		<b>Cu conc.</b>	<b>Zn conc.</b>	<b>Py conc.</b>	<b>Py tails</b>	
Average weight recovery	%	0.80	1.22	39.0	59.0	
Design weight recovery <sup>(2)</sup>	%	1.34	2.36	47.5	67.8	
Average tonnage	tph	5.4	8.3	265	401	
Design tonnage <sup>(2)</sup>	tph	8.9	16.0	323	460	
Target regrind P <sub>80</sub> to pyrite concentrate leach circuit	µm	10-12				
Pyrite concentrate pre-oxidation retention time	h	8				
Pyrite concentrate leach retention time	h	16				
Flotation tails leach retention time	h	12				
Carbon stripping, regeneration capacity	tonnes per batch	24				

<sup>(1)</sup> Actual averages compiled from mine plan of February 2017 (InnovExplo file *Séquence de minage préliminaire teneurs 11-02-2017.xlsx*), inclusive of development ore. 50<sup>th</sup> percentiles of stope tonnage distribution may thus be different.

<sup>(2)</sup> Design weight recovery and tonnages not additive since derived under different design conditions.

<sup>(3)</sup> Requirements for nominal tonnage.

## 17.2 Process Plant Facilities Description

### 17.2.1 Crushing

Crushing is performed in the underground mine and the relevant circuit is described in Chapter 16. The crushed material is hoisted to the surface and is discharged via a stockpiling conveyor onto an elongated slot established in backfilled and compacted material, covered with rip-rap.

### 17.2.2 Stockpile Reclaim

The plant feed is reclaimed using two apron feeders located beneath the covered coarse ore stockpile. The feeders are equipped with variable speed drives to control the tonnage. Cameras, coupled to a particle size analysis software, are installed between the two feeders and after the second one. Their output allows adjustment of the mixture of ore size distribution extracted from the stockpile and fed to the SAG mill.

The feeders are sized to allow operation of the plant at the design throughput with only one unit in operation, although both would typically be running to provide a better size distribution to the SAG mill.

A sump pump is installed near the tail end of the reclaim tunnel, which is the low point within the sloping tunnel. An emergency exit is located at this end.

Rails with electric hoists are mounted strategically around the feeders to facilitate maintenance and handling of spalling bars, used to isolate the feeders from the piled material above them, when required.

Because of the stockpile configuration, the only ore available from it is in the live portion of the pile since no mobile equipment could be safely working to displace a portion of the dead load to increase ore availability. A live volume estimated at 6,750 m<sup>3</sup> is provided, or about 12 hours of operation at nominal throughput.

### 17.2.3 Grinding

#### Grinding Mills Sizing

Grindability data for establishing the required grinding power requirements was obtained from a series of samples representing the different main rock types in the orebody: rhyolitic tuff, rhyolitic breccia, massive (“MS”) and semi-massive sulphides (“SMS”). The outcome of the comminution testwork outlined strong correlations of all the grinding parameters measured against the sulphur content of the samples tested, as illustrated in Chapter 13, Figure 13-11 to Figure 13-16.



These inverse correlations (e.g. ore getting softer as sulphur content is increasing) allowed to select a design sulphur feed grade, for the purpose of sizing the grinding mills, based on the analysis of the sulphur grade distribution expected from the mine plan. Both the yearly and LOM variability were considered to select the appropriate hardness design criteria to be used for grinding mill sizing.

Based on the sulphur distribution statistics shown in Figure 17-4 and the harder (e.g. lower sulphur content) material thus indicated for the latter years of the mine plan, a design sulphur content of 10%, per the yearly 20<sup>th</sup> percentile values, was selected for determining the values of the grinding indices to be used for establishing the required grinding mill power. Per the discussion in Chapter 13 on the comminution testwork, the relevant grinding parameters for mill sizing are calculated and presented in Table 17-2.

**Table 17-2: Calculated grinding design parameters at design sulphide content**

Parameter	Symbol	Units	Equation <sup>(1)</sup>	Value
Bond rod mill work index	RWi	kWh/t	$20.33 - 0.2267 \times \% S$	18.1
Bond ball mill work index @ 150 mesh	BWi	kWh/t	$17.705 - 0.1523^{(1)} \% S$	16.2
Bond ball mill work index @ P <sub>80</sub> =55 µm	BWi	kWh/t	$17.839 - 0.106^{(1)} \% S$	16.8
SAGDesign SAG work index	SDW <sub>sag</sub>	kWh/t	$18.995 \times \exp(-0.026^{(1)} \% S)$	14.6
SAGDesign ball mill work index	SDBWi	kWh/t	$23.772 - 3.233 \times \ln(\% S)$	16.3
Solids specific gravity	SG	t/m <sup>3</sup>	$2.7018 + 0.0373 \times \% S$	3.17
Abrasion Index	Ai	n/a	$1.3262 \times \% S^{-0.339}$	0.61

<sup>(1)</sup> Per regression equations shown in Chapter 13, Figure 13-11 to Figure 13-16, except for BWi at 55 µm which was derived by correcting the raw BWi measurements obtained with a test product P<sub>80</sub> coarser than the grind target. Such correction is based on the variability of the measured BWi on same samples while undergoing the BWi procedures with a closing screen size of 100, 150 and 200 mesh.

The configuration of the retained grinding circuit includes a semi-autogenous (“SAG”) mill operated in closed-circuit with a vibrating screen located at its discharge end. The oversize fraction of the screen is returned to the SAG mill feed through a series of conveyors. There is no pebble crusher included in the basic configuration, based on the low rod mill to ball mill work indices ratio displayed in Table 13-16, but a pebble bypass capability is included to facilitate its inclusion or benefit from their rejection if they were to be shown as barren. The SAG mill circuit is followed by a ball mill, operated in closed-circuit with hydrocyclones arranged in a circular cluster.

Figure 17-5 illustrates the SAG and ball mill arrangement from the 3D model.



Figure 17-5: 3D model arrangement of the SAG mill and ball mill circuit

Three methodologies were used for sizing the grinding mills, on the basis of the type of grindability data gathered from testwork.

Two methods make use of the Barratt/Allan modified method, where the Bond rod and ball mill work indices are used to calculate the grinding energy indicated for such a circuit configuration. To this energy is added an estimate of the crushing power typical for secondary and tertiary crushing stages, as would have been necessary to prepare feed for a rod mill. The total comminution energy required to bring the plant feed to the required size distribution for feeding the flotation circuit is then apportioned between the SAG and ball milling circuits. Appropriate safety factors are applied to reflect differential energy efficiency levels within different mill types. This is the approach adopted by BBA and Alex G. Doll Consulting (“AGDC”), where the latter is making use of proprietary databases to validate through benchmarking the input data and select efficiency factors.

The third method uses Starkey & Associates Inc.’s (“Starkey”) proprietary SAG Design methodology, incorporating specific grinding indices measured to suit its specific requirements. With an index specific to each of the SAG and ball mill grinding environment, the energy requirement for each mill is calculated accordingly.

In both cases, sizing of the individual mills is then derived from the power draw capability for mills of a given size, as they are operated within normal rotational speed ranges and ball loading conditions, with balls of an appropriate size for the duty at hand, and with normal solids charge and slurry density.

## SAG Mill Circuit

The reclaimed coarse ore is conveyed to the SAG mill. Water is added to the mill feed chute to achieve the desired slurry density within the mill. Nominal tonnage is rated at 679 tph (15,000 tpd at 92% availability), with the design ore hardness, whereas the plant downstream equipment sizing can readily accommodate 15% more tonnage with softer ore. A SAG mill size of Ø10.97 m x 5.41 m (Ø36 ft x 17.75 ft) EGL was selected for providing the power draw indicated of 8.5 MW at the pinion with the design ore. The mill drive train includes a twin-pinion arrangement powered by two low-speed synchronous motors of 6.7 MW (9,000 hp) each, making these units equal in size to those required to cover the ball milling duty, for spare commonality.

The mill is operated with a charge of Ø125 mm steel balls intermittently added to the mill feed chute so as to maintain the desired media filling required to uphold the power draw and throughput capability.

The coarse fraction obtained from the 3.66 m x 7.32 m (12 ft x 24 ft) screen installed below the SAG mill discharge trunnion is returned to the SAG mill feed conveyor via a series of transfer conveyors. The pebble flow could also be bypassed and accumulated on the ground outside the process plant. Nevertheless, the initial SAG mill lining set is expected to include slotted discharge grates only, without pebble ports. The screen, under these conditions, would be receiving only material passing through the 12 mm wide slots and the size of its oversized material serves as an indication of the gradual wear of the grates, as well as a protection for the pump box and pumps underneath in case of a catastrophic grate failure.

The screen undersize drops into a pump box receiving this stream as well as the ball mill discharge. A centrifugal pump feeds this slurry to the cyclone cluster. The transfer size to the ball mill ( $T_{80}$ ), under design conditions, is estimated at 1,200 µm, with a screen deck featuring apertures of 3.7 mm.

Control of the SAG mill operation is enhanced by adding size-monitoring cameras on the conveyor feed belt for size distribution control, variable speed capability to the mill rotational speed, an acoustic detector to gauge and control the overall charge level, and an expert system capable of optimizing throughput while protecting the mill from overload conditions. The dilution of the SAG mill feed solids stream is controlled with a flowmeter and control valve on the water feed line.

The SAG mill area is serviced by an overhead crane for maintenance duties and ball addition with a bucket loaded from a ball bin located within the process plant. Two sump pumps, one at the feed end and one at the discharge end of the SAG mill are installed to collect spillage directed towards the sump with a sloping basement floor.

## Ball Mill Circuit

A ball mill of  $\text{Ø}7.62\text{ m} \times 11.43\text{ m}$  ( $\text{Ø}25\text{ ft} \times 37.5\text{ ft}$ ) EGL was selected for the power draw requirement of 11.5 kWh/t indicated for the design ore (at the pinion). The drive train is based on a twin-pinion configuration fitted with low-speed synchronous motors of 6.7 MW (9,000 hp).

The ball mill is operated in closed-circuit with a cluster of  $\text{Ø}400\text{ mm}$  cyclones producing an average product  $P_{80}$  of 55  $\mu\text{m}$  as flotation feed, with a pulp density of 35% solids (weight basis). A sufficient number of cyclones are provided to cover a circulating load of up to 450%, whereas the nominal flow is based on 350%.

The cyclone cluster is fed with the combination of the SAG screen undersize and ball mill discharge slurry via a variable-speed centrifugal pump (with one stand-by unit). The ball mill is charged up to 30% of its volume with a mixture of  $\text{Ø}50$  and  $\text{Ø}63.5\text{ mm}$  steel balls, added intermittently via a bucket placed on the ball mill feed chute with the overhead crane of the grinding bay.

The grinding efficiency of the circuit is monitored by an on-line particle size analyzer, receiving a sample of the cyclone feed and cyclone overflow slurry, thus providing a regular feedback of the  $P_{80}$  to the flotation as well as the size distribution of the circulating load around the ball mill. Controls of the cyclone feed pressure (via the number of operated cyclones with automated on/off valves), of the cyclone feed pump box level (via variable speed capability of the feed pump motor) and of the cyclone feed slurry density (via controlled addition of water to the cyclone feed pump box with a control valve and flowmeter on the water line and density and flowrate monitoring of the cyclone feed) are provided. These measures ensure a proper size classification at all times and efficient use of the ball mill power.

The ball mill area is serviced by an overhead crane used for maintenance duties and for ball addition to the mill, from a ball bin located within the process plant. Two sump pumps, one at the feed end and one at the discharge end of the ball mill, are installed to collect spillage directed towards the sump with sloping basement floor.

### 17.2.4 Flotation

The design flowrates for the sizing of the roughing stages of the three flotation circuits are based on the same criteria as applied for the grinding circuit, of nominal throughput plus 15%, equating to 781 tph.

As for the copper and zinc cleaning circuits, consideration was given to the yearly variability of the feed grades of copper and zinc, respectively. The design feed grades were established by considering the peak years for copper and zinc and adding a margin 25% above these values, to reflect short-term peaks to be expected in the plant feed stream during the course of said years. The design flows within the cleaning circuits indicated by such consideration were matched with a plant operating at its nominal throughput, not the design value, to avoid oversizing of the circuits in question.

Based on the mass balance around the circuits, feed flowrates per flotation stage under nominal and design conditions were established and used to calculate the net flotation cell volume required to cover the needs. Scale-up factors were applied to the gross laboratory-scale flotation time, to account for short-circuiting within an industrial flotation cell bank. The type of cell, as individual tanks vs. flow-through series of cells in each row, was taken into account when setting said scale-up factors.

### Flotation Cell Sizing

The configuration of the flotation circuits is derived from the flowsheet which evolved from batch flotation trials completed at SGS' Lakefield laboratory. From this work, which included kinetic rougher tests, the retention time for each flotation stage was also assessed.

Table 17-3 is presenting the design criteria thus applied for sizing the individual flotation stages and the indicated resulting configuration to be provided.

Table 17-3: Flotation stages design criteria and cell sizing

Parameter	Units	Cu Circuit					Zn Circuit					Py Circuit
		Cu Rougher	Cu 1 <sup>st</sup> Cleaner	Cu Cleaner Scavenger	Cu 2 <sup>nd</sup> Cleaner	Cu 3 <sup>rd</sup> Cleaner	Zn Rougher	Zn 1 <sup>st</sup> Cleaner	Zn Cleaner Scavenger	Zn 2 <sup>nd</sup> Cleaner	Zn 3 <sup>rd</sup> Cleaner	Py Rougher
Design feed tonnage, solids	tph	781	32	22	13	9	771	36	22	19	15	755
Slurry density	% solids	35	22	22	18	16	32	13	8	18	17	31
Slurry flowrate	m <sup>3</sup> /h	1,687	125	90	60	48	1,684	215	145	84	82	1,729
Solids SG		3.32	3.55	3.40	3.85	4.00	3.31	4.07	4.15	4.00	4.09	3.29
Slurry S.G.		1.32	1.18	1.18	1.14	1.14	1.28	1.11	1.06	1.15	1.15	1.28
Particle size distribution, P <sub>80</sub>	µm	55	50	55	50	50	55	50	55	50	50	55
Flotation air holdup	%	12	15	12	15	15	12	15	12	15	15	12
Laboratory retention time	min	8.0	3.5	5.3	3.0	2.5	5.0	4.0	6.0	3.0	2.0	10.0
Scale-up factor		2.5	2.5	2.5	2.5	2.5	2.0	2.5	2.5	2.5	2.5	2.0
Scaled-up required retention time	min	20.0	8.8	13.1	7.5	6.3	10.0	10.0	15.0	7.5	5.0	20.0
Total net cell volume required	m <sup>3</sup>	639	21	23	9	6	330	27	49	24	14	655

## Flotation Circuit Description

The overall flotation section of the process plant is divided into three major circuits dedicated to recovering either copper, zinc or pyrite. Gold and silver units are also reporting to each of these concentrates, with payable contents placed in the copper and zinc concentrates sent to smelters. Additional precious metals units reporting to the pyrite concentrate and tails are then directed to their respective leaching circuits, following the pyrite flotation section.

The copper and zinc flotation circuits are further sub-divided in two major sections: a roughing and a cleaning circuit, whereas the pyrite circuit only comprises a roughing section.

The cells are all of the tank type and fitted with rotor/stator assembly designed to optimize recovery of fine solids. All cells are fitted with automated level and flotation airflow controls, either individually or as paired units.

Figure 17-6 and Figure 17-7 illustrate the general circuits' arrangement, as extracted from the 3D model.



Figure 17-6: Configuration of the flotation circuit – close-up on copper and zinc circuits





Figure 17-7: Configuration of the flotation circuit – close-up on the pyrite circuit

The critical streams needed to provide on-going feedback to the operators, in terms of achieved grades and calculated recoveries, are fitted with samplers continuously extracting a representative sample of the targeted flows. These samples are typically reporting, through vertical froth pumps, to an X-ray diffraction-based on-stream analyzer (“OSA”) system that provides assay data for each stream. Accounting samples are also collected on a shift basis at the OSA sample feed multiplexing stations for assessing metallurgical performance with composite samples to be processed in an assay laboratory. These composite samples are created through the accumulation of multiple individual increments taken throughout each shift. Each increment is fed to a lab-scale filtration bench fitted with a vacuum pump so as to permit the accumulation of a few kilograms of filtered cake per shift, thus yielding a representative sample of the whole shift duration without operator intervention during the period.

Eleven flotation streams report to one five and one six-position multiplexers located above the OSA room and are sequentially presented to the OSA for measuring the copper, zinc and iron content of the streams, as well as providing an indication of the slurry density (percent solids).

The assay data, coupled with flow rate measurements at select locations within the flotation circuits, is used to enable automated reagent addition controls throughout the circuits. This functionality is enhanced through the use of froth cameras above the flotation cells, coupled with image analysis software indicating flotation froth lateral velocity, colour and density of the froth, as well as bubble size in real time.

Pumping of intermediate flows between flotation stages is provided with centrifugal pumps tied to dedicated pump boxes. Variable speed capability is provided where needed to cope with large expected inflow ranges. The pumps are duplicated, with the provision for one stand-by unit per duty, with all the required automated valving to complete a switch to remotely operated unit.



Each roughing and cleaning circuit is divided by low retaining walls at the basement level and sloping floors. These are sloping towards the centre of the flotation row, where a sump pump allows spillage collection and redirection in the appropriate flotation section. Only the pyrite roughing section receives two such sump pumps, considering the large volume of both tailings and concentrate that needs to be handled there. The flotation area is serviced by an overhead crane.

### Copper Flotation

The fine fraction of the cyclones (cyclone overflow) flows to a row of five copper rougher flotation cells. The flotation cells are 130 m<sup>3</sup> tank cells, providing a design retention time of 20 minutes. The rougher concentrate is sent to the cleaning circuit, while the tailings proceed to the zinc rougher feed.

The cleaning circuit is arranged along a conventional countercurrent configuration, with three stages of cleaning closed by a cleaner-scavenger. The concentrate from each step is brought as the fresh feed source to the following stage, while the tailings are recycled to the previous stage as a circulating load. The cleaning circuit is opened at the cleaner-scavenger, with the tailings making their way to the zinc rougher circuit feed, and at the third cleaner with its concentrate brought to the copper concentrate dewatering circuit.

The first cleaning stage comprises three 10 m<sup>3</sup> tank cells, the second and third stages are made up of two and one 10 m<sup>3</sup> cells, respectively, while the cleaner-scavenger has three 10 m<sup>3</sup> cells. The design retention times provided thus equate to 12 min, 17 min, 11 min and 17 min, respectively.

Reagents used in the copper flotation process are:

- SIPX (sodium isopropyl xanthate) as the main sulphide collector;
- Aerofloat R208 (diisobutyl dithiophosphate) as a precious metals promoter;
- MIBC (methyl isobutyl carbinol) as the frother;
- Hydrated lime as a pH modifier.

### Zinc Flotation

The copper rougher and cleaner-scavenger tails are combined to form the feed to the first of two conditioners arranged in series. These are used to activate the sphalerite and adjust the pH. The final conditioner overflows into a row of five zinc rougher flotation cells. The flotation cells are 70 m<sup>3</sup> cells providing a nominal retention time of almost 11 minutes. The rougher concentrate is sent to the zinc cleaning circuit, while the tailings proceed to the pyrite rougher feed.

Similar to the copper cleaning circuit, the zinc cleaning circuit is arranged in a conventional countercurrent configuration, with three stages of cleaning closed by a cleaner-scavenger. The zinc cleaning circuit is opened at the cleaner-scavenger tails, sent to the pyrite rougher circuit, and at the third cleaner concentrate, brought to the zinc concentrate dewatering circuit.

The first cleaning stage comprises three 20 m<sup>3</sup> tank cells, the second and third stages are made up of three and two 10 m<sup>3</sup> cells, respectively, while the cleaner-scavenger has three 20 m<sup>3</sup> cells. The design retention times thus provided equate to 14 min, 11 min, 8 min and 21 min, respectively.

Reagents used in the zinc flotation process are:

- CuSO<sub>4</sub> (copper sulphate) as sphalerite activator;
- SIPX as the sulphide collector;
- MIBC as the frother;
- Hydrated lime as a pH modifier.

### Pyrite Flotation

The zinc rougher and cleaner-scavenger tails are fed to the six pyrite rougher flotation cells. The flotation cells are 130 m<sup>3</sup> cells providing a nominal retention time of 24 minutes. The rougher concentrate and tails are sent to their respective dewatering step, ahead of cyanide leaching for gold recovery.

Reagents used in the pyrite flotation process are:

- PAX (potassium amyl xanthate) as the collector;
- MIBC as the frother.

### 17.2.5 Concentrate Dewatering

The same design feed grades, applicable to the sizing of the flotation cleaning circuits, are retained for sizing of the concentrate thickeners and filters.

### Thickener Sizing

Static and dynamic testwork performed on samples of the copper and zinc concentrates provided the basis for sizing of the thickeners. Rheology testing also indicated that targeting underflow densities of 65% solids was feasible and remained away from the inflection point where the slurry viscosity increases rapidly with increasing slurry density.

Table 17-4 presents the design criteria retained for sizing the concentrate thickeners.

Table 17-4: Concentrate thickeners sizing criteria

Parameter	Units	Cu concentrate	Zn concentrate
Circuit utilization	%	98	98
Design feed rate	tph	8.9	16.2
Feed slurry density	% solids	12.1	12.6
Target underflow density	% solids	65	65
Thickener type		Conventional, with high-rate feedwell	Conventional, with high-rate feedwell
Unit capacity indicated	tph/m <sup>2</sup>	0.64	0.71
Underflow density reached at unit capacity	% solids	78	71
Flocculant addition rate	g/t of feed	15	25
Solids in overflow stream	ppm	150-250	150-250

### Concentrate Thickener Circuits

The flotation concentrates are pumped to their respective thickener feed box, where the slurry velocity is reduced and froth de-aeration induced before introducing the slurry by gravity into the thickener submerged feed pipe. An internal slurry dilution system is reducing the slurry density within the thickener feedwell. Flocculant is added along the feed pipe and/or into the feedwell to assist the thickening process and reduce the loss of solids into the overflow stream.

The thickeners have been generously sized, with the tanks per conventional thickener criteria and feedwell as high rate units, in order to ensure appropriate underflow densities even under upset feed conditions and to minimize the loss of valuable solids at the overflow streams. This approach would result in thickener diameters of 4.5 m and 5.8 m, respectively for the copper and zinc concentrate duties. Considering the small size indicated, two Ø6 m units are specified.

The rake mechanism is specified for an equivalent underflow slurry density requirement of 5% above the design target of 65% solids.

Skirt boards and froth-skimming arrangements are included to further minimize the loss of solids into the overflow streams. The overflow streams are brought to the process water tank, for recycling into the grinding and flotation circuits.

Each one of the thickener underflow slurry is extracted via peristaltic pumps, with one operated and one stand-by unit per thickener. A sump pump is located below each thickener, near its cone, to re-collect spilled material and bring it back into the thickener feed tank.

The thickeners are instrumented for appropriate operation, prevention of sanding situation and protection of the rake mechanism. The instrumentation package includes:

- Hydraulic rake drive protection with rotation speed and torque monitoring and control with raise-lower capability of the rake mechanism. Typical monitoring and alarms for an hydraulic drive, such as pressure, oil temperature and level, are also included;
- Overflow clarity optimization with a feed-forward control loop on the flocculant addition, with feed flowrate measurement and metering pump variable-speed capability to maintain a setpoint in g/t of thickener feed. In-line dilution of the flocculant with water, before it reaches the thickener, is also implemented to enhance its efficiency. Monitoring of the thickened slurry interface level is also used to adjust the flocculant addition setpoint, as required;
- Underflow density controls include density monitoring of the retrieved thickened slurry coupled with variable-speed capability of the underflow pumps and thickener solids inventory monitoring, via a pressure transmitter installed in the underflow cone of the thickeners. Under a situation where a low underflow density is achieved, and during plant shutdown situations, a recirculation loop bringing back the underflow into the thickener feedwell so as to rebuild the density towards the desired setpoint, or prevent sanding of the thickener during the plant stoppage.

The thickeners are located outside, with the bottom of the tank elevated on support beams. The peripheral wall below the thickeners is enclosed by insulated cladding while the top portion is covered with a light structure allowing access to the overflow launder all around. A removable hatch covers the central portion of the roof, over the rake mechanism, for maintenance access with a mobile crane. A beam running the length of the thickeners radius, above the access platform, allows for the installation of a chain block to move heavy parts in and out from the ground elevation to the platform and to the drive mechanism.

### Concentrate Filter Sizing

Samples of the concentrates were tested and established the filtered cake density and relationship between required air-blowing time versus residual moisture achieved, at different cake thickness.

Sizing of the filtration circuit equipment is derived with consideration of a utilization rate set at 50% since the retained configuration is calling for direct shipping of the filtered concentrates, as they are being filtered and discharged in either trucks (for copper concentrate) or railcars (for zinc concentrate). The low utilization rate allows for a requirement at site and delivery of trucks to the smelter during limited hours of the day, to match smelter receiving hours and put the trucks on public roads during low affluence.

Based on the testwork data and typical industrial-scale metrics for the operation of such equipment, the sizing criteria used for the concentrate filters are indicated in Table 17-5.

Table 17-5: Concentrate filter sizing criteria

Parameter	Units	Cu concentrate	Zn concentrate
Circuit utilization	%	50	50
Design feed rate	tph	17.8	32.4
Feed slurry density	% solids	64	64
Target residual moisture content	% moisture	10	10
Filter type		Pressure filter – vertical plates	Pressure filter – vertical plates
Retained plate area	m x m	1.5 x 1.5	1.5 x 1.5
Retained filtration chamber depth	mm	50	50
Indicated dry cake density	kg/m <sup>3</sup>	2,355	2,137
Slurry feed time	min	3	3
Air drying time	min	5	5
Total filtration cycle time	min	12.75	12.75

### Concentrate Filtration and Loadout Circuits

The thickened products are transferred into their respective agitated surge tank, placed ahead of a single dedicated pressure filter. The surge tanks are sized to provide a buffer capacity equivalent to 20 hours of concentrate production, at design feed rate. The filter feed pumps (one operated and one stand-by unit per concentrate) are fitted with soft-start, providing a programmed speed ramp-up of the slurry velocity fed through the filter cloth before an initial cake is formed. Both the stock tank agitator and underflow pumps are sized to accommodate slurry densities, and their related viscosities, of 5% above the operating target of 65% solids.

The concentrates are dewatered to a target of 10% residual moisture content. Nominally, vertical plate filters were sized with 1.5 m x 1.5 m individual plates. Filter frame sizes were selected to accommodate 15% additional plates above those required for the design feed grades. The filter sized for copper duty would have a frame capable of holding 20 plates, with 17 installed. A frame for up to 41 plates, but fitted with 35, was retained for the zinc duty.

The slurry feed, diaphragm pressing and air blow drying portions of the full filtration cycle are controlled by the loss-of-weight indication provided by the load cells mounted under the filters. Filtrate, cloth wash water and drippings onto the bomb bay doors beneath the filters are collected and redirected to the respective concentrate thickener.

The filter cake is discharged directly into an awaiting transportation vessel: a truck for copper concentrate and railcar for the zinc concentrate. Weight indication from the load cells under the filters is used for controlling the wet tonnage of concentrate accumulated in the trucks or railcars.

A sump pump is installed on the copper and zinc loadout sides of the loadout building, to re-collect spillage from the filtration floor above, and from floor washing of the loadout. The collected solids are pumped back in either of the concentrate thickeners. The loadout is open solely on the north side of the building and is fitted with a door, to allow access of railcar and truck and to keep the area closed while loading is on-going.

Figure 17-8 and Figure 17-9 illustrate, respectively, the general arrangement for the concentrate thickeners and filters as extracted from the 3D model.

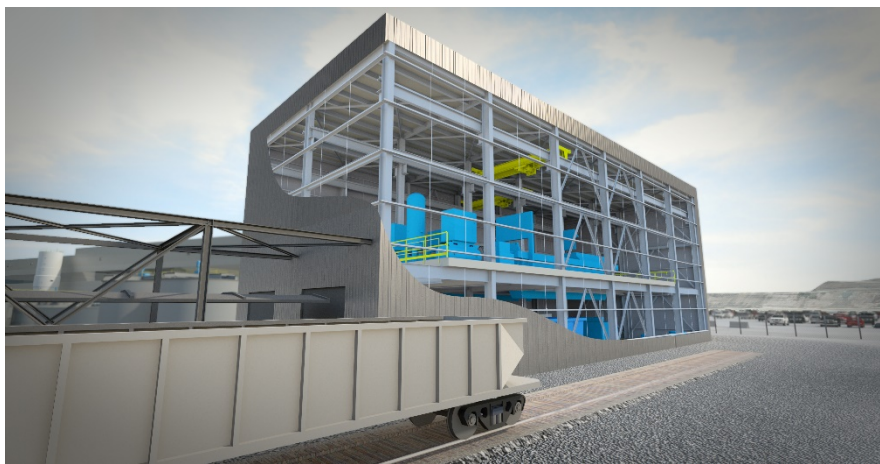

Figure 17-8: Concentrate dewatering area – view from west



Figure 17-9: Concentrate dewatering area – view from east

## 17.2.6 Pre-leach Thickening

### Thickener Sizing

Both the pyrite concentrate and tailings undergo a thickening step before reaching their respective leaching circuits.

Thickening tests demonstrated the underflow density reachable with the materials in question, as well as the associated viscosity profile, for appropriate sizing of the thickener tank, rake mechanism and underflow pump power. Table 17-6 is presenting an overview of the design criteria applicable to this plant section.

Table 17-6: Pre-leach thickeners sizing criteria

Parameter	Units	Py concentrate	Py tailings
Circuit utilization	%	98	98
Design feed rate	tph	323	459
Feed slurry density	% solids	18.4	31.6
Target underflow density	% solids	65	60
Thickener type		high-rate	high-rate
Unit capacity (UA) indicated	tph/m <sup>2</sup>	1.23	0.41
Underflow density reached at UA	% solids	74.5	63.5
Flocculant addition rate	g/t of feed	25	30
Solids in overflow stream	ppm	150-250	150-250

### Circuit Description

The pyrite concentrate and tailings transit into a pump box fitted with variable speed drives (one operating, one stand-by per duty).

For the pyrite tails, the slurry flows to a pair of vibrating trash screens, removing material over 600 µm so as not to interfere with the activated carbon screening found downstream of this circuit.

The trash screen undersize and the pumped pyrite concentrate slurry are directed towards their respective in-line sampler which extracts a sample presented to the OSA and where a shift sample is accumulated through extraction of multiple increments over the shift duration, which are filtered near the point of collection, on a bench-scale filtration system. The OSA samples are used for controlling the pyrite flotation circuit while the shift samples are collected, dried, quartered and assayed for the accounting metallurgical balance preparation.



The flows then enter their respective thickener feed box and reach the thickener feedwell through a submerged feed pipe. An internal slurry dilution system reduces the slurry density within the thickener feedwell. Flocculant is added along the feed pipe and/or into the feedwell to assist the thickening process and reduce the loss of solids into the overflow stream.

The design criteria presented in Table 17-6 yield thickener diameters of 18 m for the pyrite concentrate and of 38 m for the pyrite tailings. The rake mechanisms and underflow pump power are specified for an equivalent underflow slurry density, and associated viscosity, of 5% above the design target of 65% and 60% solids, respectively.

Skirt boards on both units and froth-skimming arrangement for the pyrite concentrate duty are included to further minimize the loss of solids into the overflow streams. The overflow streams are brought to the process water tank, for recycling into the grinding and flotation circuits.

Each of the thickener underflow is extracted via centrifugal pumps, with one operated and one stand-by unit per thickener.

Instrumentation and controls are similar to those described for the base metals thickeners, under Section 17.2.5. As for these thickeners, the tanks are elevated and the periphery of the equipment, below the tanks, is enclosed with insulated cladding. Sump pumps are installed to reclaim spillage. A beam running the length of the equipment radius, above the access platform, allows for the installation of a chain block to move heavy parts in and out from the ground elevation to the platform and to the drive mechanism.

## 17.2.7 Pyrite Concentrate Regrinding Circuit

### Pyrite Concentrate Regrinding Power

The signature curve established through testing of three samples of pyrite concentrate, per Figure 13-50, is used to derive the required power for HIG mills operated under the design throughput indicated by the 80<sup>th</sup> percentile of the sulphur distribution. Trials on-going at a Finnish operation, where the HIG mill lower discs were modified to enhance their wear resistance, indicated the potential of such configuration to reduce, as well, the required grinding energy. The lab-scale test unit used to establish the signature curve was not fitted with such discs, nor has Outotec proven yet that the scaling-up of such an effect from laboratory to industrial plant would be valid and repeatable from one material to another. On this basis, no further power credit was assumed for sizing of the HIG mills.

A regrind product target size of 12  $\mu\text{m}$  is sought when handling the design tonnage, whereas finer results would prevail with a lower throughput, allowing a  $P_{80}$  towards 10  $\mu\text{m}$  to be reached at times, as illustrated by Table 17-7. A specific grinding energy (“SGE”) of 43.9 kWh/t is indicated to reach a  $P_{80}$  of 12  $\mu\text{m}$  (47.7 kWh/t including drive and reducer losses for a 92% efficiency) while the SGE increases to 62.4 kWh/t for a  $P_{80}$  of 10  $\mu\text{m}$ , or 42% higher.



Table 17-7: Regrinding duty – effect of throughput on power demand and P<sub>80</sub>

Operating Conditions		Feed tonnage	Power, kW	Number of mills running	P <sub>80</sub> at max power
		tph	@SGE for P <sub>80</sub> =12 µm	for P <sub>80</sub> =12 µm	µm
Minimum	Nominal tonnage at low %S	205.4	9,800	1.96	9.6
Nominal	Nominal tonnage at average %S	266.1	12,700	2.57	11.0
Design	Design Tonnage at average %S	306.1	14,600	2.92	11.8
Design	Nominal Tonnage at High %S	322.8	15,400	3.08	12.2

### Pyrite Concentrate Circuit Description

The power demand calculated is indicating a requirement for three HIG mills of the model fitted with 5 MW motors. Thickened concentrate from the pre-leach thickener is drawn by three operated underflow centrifugal pumps (with one common stand-by unit), fitted with variable-speed capability. These streams are sent to parallel pump boxes used to deliver the slurry to three parallel vertical regrinding mills, at the required feed pressure. Per indications provided by the HIG mills supplier, the regrind mills are to be operated at a slurry density of 55% solids. The dilution from the slurry density used to operate the pre-leach concentrate thickener is thus occurring in the HIG mill feed pump boxes, using a ratio controller making use of the measured flow and density of the thickener underflow streams and control valves coupled with flowmeters on the dilution water lines.

The mills are operated in open circuit. The mill product is sampled after transiting to dedicated pump boxes and transfer pumps (with stand-by units for each) bringing the slurry to the leach circuit. These samplers are providing input to a single particle size monitor capable of receiving the three products sequentially. The indicated product size can be used to increase the media load in the HIG mill. An indication of the media charge is provided by pressure transmitters mounted on the side of the mill shell, at different heights, as well as from the torque measurement of the drive.

The variable-speed capability of the HIG mill drive can be used to maintain the P<sub>80</sub> at a fixed value but the incremental recovery achievable for a smaller product, as outlined by Equation 13-19, is providing an incentive to always operate the mills at their maximum speed and reap the extra recovery which may arise under low feed tonnage to the regrinding circuit.

The grinding media is made up of ceramic beads in the 2.0-2.5 mm range, with a density of 3.7-4.0 as suitable for grinding the heavy pyrite concentrate (SG of 4.5-4.7). Fresh media addition is made through a hopper receiving one tonne tote bag of fresh media and a screw feeder delivering the balls to the top of each mill. Recharging of the complete media charge following its discharge for maintenance purpose is to be completed through the reclaiming of the charge on the operating floor and into the area sump. The sump pump discharge is then temporarily redirected towards the HIG mill feed pump box of the unit requiring media replenishment.

The regrinding area is serviced by an overhead crane with a capacity sufficient to remove a complete shaft assembly, with the discs mounted, or the motor/reducer assembly. Typical maintenance would seek to replace one of the bottom discs along the shaft. Opening of the shell is helped by hydraulic wrenches removing bolts along the flanges of the two vertical cans as well as along the lower horizontal flange, so as to expose only the discs at the bottom of the shaft. The elements of the shell are supported during this work by electric hoists mounted below the operating floor of the regrind mills. A hydraulic support table is used to deposit the removed disc, move it out of position and bring back and align a replacement disc on the same table.

When a major overhaul of the shaft wear components is required, the bolts of the vertical flange are removed from the whole length of the shell and it is pried open to expose the shaft assembly. A special transport dolly allows for depositing the shaft assembly on the basement floor and for moving it in position for pick up by the overhead crane. An access door in this area, at ground level, allows for the transfer of the shaft assembly on a flatbed transport truck. In the same fashion, a spare shaft assembly is then put into position to bring the disabled regrind mill back into operation.

Figure 17-10 illustrates the HIG mills physical arrangement, as extracted from the 3D model.



Figure 17-10: Configuration of the pyrite concentrate regrinding circuit

## 17.2.8 Cyanidation Circuits

### Equipment Sizing

Cyanidation, or leaching circuit sizing is derived from the kinetic leach curves established during laboratory plant trials and the application of the design feed flowrate applicable, as per the mass balance. In the case of the pyrite concentrate, the addition of a pre-oxidation circuit ahead of the leaching proper has been demonstrated to be beneficial in order to reduce the sulphides activity and resulting cyanide and oxygen consumption.

Since oxygen addition is required for maintaining dissolved oxygen (“DO”) concentration throughout the pyrite concentrate pre-oxidation and leach circuit, the same oxidant is used for the pyrite tailings.

### Circuit Description

Both the pyrite concentrate and pyrite flotation tailings are leached with cyanide for recovery of gold and silver values.

In the case of the pyrite concentrate, the product of the regrinding circuit reports to a pre-aeration tank where a dilution of the slurry to 45% solids is first completed with cyanide-bearing water. A further dilution to 35% is then made at the first leach tank. Adjustments to the pH and DO are made with the assistance of a pH meter, DO measurement and control valves on the lime and oxygen additions. A retention time of 8 hours in the pre-oxidation circuit is provided before the slurry reports to the concentrate leaching circuit proper; affording a drop in height between the pre-oxidation tank and the first leach tank, for gravitational flow, and adjusting the tank height so as that of the first leach tank leads to a diameter of 16.1 m for the pre-oxidation tank and leach tanks.

A dilution of the pyrite tailings pre-leach thickener underflow slurry, to 55% solids, is made through the controlled addition of cyanide-laced water, as recovered ahead of the cyanide destruction (“CND”) circuits. Density and flowrate measurements of the thickener underflow slurry enable a metered addition of dilution water, via a control valve and feedback from a flowmeter on the water addition line.

In both circuits, the agitators and related motors are sized to accommodate a slurry density of up to 5% above the normal operating conditions, allowing flexibility to the operators.

The pyrite concentrate leaching circuit comprises four cyanidation tanks installed in series, providing an overall retention time of 16 hours. The nominal diameter of 16.1 m comes with variable height, to accommodate a differential of 0.6 m between tanks to ensure proper gravitational flow from one tank to the next. For the flotation tails, four tanks of Ø13 m are used to reach the required retention time of 12 hours, again with a drop of 0.5 m between each tank of different height. For both circuits, each tank can be bypassed through a series of external launders fitted with isolation valves.

All the leaching tanks are provided with individual metered oxygen sparging and staged metered addition points for cyanide and lime for pH control. Feedback of the required setpoints is provided by two measurements of the available cyanide in solution, per leach circuit, and two pH and DO measurements.

The pre-oxidation and leach tanks are fitted with dual hydrofoil impellers, providing for a vigorous agitation. Coupled with an oxygen sparging ring at the bottom of the tanks, they ensure an adequate contact of the slurry solids with oxygen and cyanide.

The tanks of the pre-oxidation and leach circuits are located outside of the process plant, within a contained concrete-walled area with a volumetric capacity of 125% of the largest tank present. Maintenance of the tank agitators is provided via mobile crane access. Each circuit discharge gravitates back into the process plant and to their respective CIP circuit.

Figure 17-11 illustrates the pyrite concentrate and tailings leach tanks arrangement, as extracted from the 3D model.



Figure 17-11: Configuration of the leach tanks

## 17.2.9 Carbon-in-Pulp Circuits

### CIP Circuit Sizing

The sizing of the two CIP circuits, one dealing with the pyrite concentrate and the other with the pyrite flotation tails, have been derived from simulations provided by the supplier of the PumpCell technology, as sole-sourced for this duty.

The simulations took into account the design flowrates for sizing the individual tank sizes and the solution loading with dissolved gold and silver to dictate the number of tanks per circuit and the frequency of loaded carbon removal. Table 17-8 presents the design criteria and resulting operating parameters retained for these circuits.

Table 17-8: CIP circuit design criteria and operating parameters

Parameter	Units	Py concentrate	Py tailings
Circuit utilization	%	92	92
Design feed rate	tph	323	460
Feed slurry density	% solids	35	55
Design dissolved metal loading	mg/L Au	1.18	0.25
	mg/L Ag	10.45	2.49
Adsorption efficiency (at avg grade)	Au, %	99.6	98.9
	Ag, %	98.8	94.3
Retention time per tank (design, c/w carbon transfer flow)	min	21.7	12.7
Interstage screen opening	µm	800	800
Interstage screen area	m <sup>2</sup>	11	8
Screen flux during carbon transfer	m <sup>3</sup> /h/m <sup>2</sup>	81	76
Loaded carbon withdrawal frequency		1 per day	1 per day
Carbon weight extracted per strip	t C	15	6.5
Carbon loading at design circuit feed tonnage and design Au, Ag grades	g Au / t C	979	313
	g Ag / t C	8,625	3,064
Carbon concentration in tanks	g/L	50	50

## CIP Circuit Description

The leached slurries of pyrite concentrate and tails flow through their respective line of CIP tanks, each with an inventory of 6 mesh x 12 mesh activated carbon used to adsorb the dissolved gold and silver values (along with a portion of other base metals that may be present, mainly copper), as leached by the cyanide. The CIP train for the pyrite concentrate includes eight tanks of 300 m<sup>3</sup> each, while the one for the pyrite flotation tails has six tanks of 130 m<sup>3</sup>. All the tanks in a series are of the same diameter and height.

The tanks are equipped with an agitator to maintain the slurry in suspension and rotate the submerged “pumping” screens, thus creating an updraft of the slurry that allows it to exit from one tank and flow into the next through a volute and interconnection piping. Each tank can be bypassed from the series in operation, as used during drainage of the loaded carbon from a tank or screen maintenance, which requires that the whole motor/reducer/agitator/screen assembly be removed from an empty tank.

For transfer of the loaded carbon inventory of the first tank of a given CIP tank row to the elution circuit, a recessed impeller pump (one operated, one stand-by per row) is used to drain the targeted tank of its slurry and carbon while it is bypassed by the fresh slurry flow. The slurry extracted from the tank is presented to one of two parallel vibrating screens for separating the coarser carbon from the solids in the slurry. These and most of the slurry water are returned to the head of the CIP circuit where they came from while the washed loaded carbon is accumulated in the acid wash vessels, located at the head of the gold elution circuit. The transfer pumps are sized to complete this task within two hours.

Fresh and regenerated carbon is returned to the drained CIP tank once it has been filled with the slurry exiting the last tank currently in operation in a given CIP circuit, so as to replenish its carbon inventory and allow reinsertion of the tank into operation, now as the last tank in the row.

Internal CIP tank screens are regularly washed with high-pressure water while resting on a maintenance stand. Visual inspection of the washed screen surface before putting it back into its CIP tank is performed to ensure that the screen mesh is not damaged.

The CIP area is serviced by an overhead crane shared by the gold circuit. Sump pumps are located in the basement floor of each circuit.

Figure 17-12 illustrates these arrangements, shown between the regrinding circuit, paste backfill plant and the gold recovery circuits, as extracted from the 3D model.





Figure 17-12: Configuration of the CIP and gold recovery circuits

The tailings from each CIP circuit are screened on a vibratory safety screen and then sent to the feed box of the respective pre-detoxification thickening stages, used to recover residual cyanide in solution. The tailings are sampled by in-line samplers and a shift sample is gathered to assess the leach recoveries achieved in the combined leach/CIP sections.

### 17.2.10 Pre-detoxification Thickening

#### Thickener Design Criteria

Both CIP tailings streams (PCT and PFT) undergo a thickening step before reaching their respective cyanide destruction (or detoxification) circuits.

Thickening tests demonstrated the underflow density reachable with the materials in question, as well as the associated viscosity profile, for appropriate sizing of the thickener tank, rake mechanism and underflow pump power. Table 17-9 presents an overview of the design criteria applicable to this plant section.

Table 17-9: Pre-detoxification thickener sizing criteria

Parameter	Units	Py concentrate	Py tailings
Circuit utilization	%	98	98
Design feed rate	tph	323	406
Feed slurry density	% solids	33	53
Target underflow density	% solids	53	60
Thickener type		paste	high-rate
Unit capacity (UA) indicated	tph/m <sup>2</sup>	0.35	0.51
Underflow density reached at UA	% solids	53	63.5
Flocculant addition rate	g/t of feed	50	20
Solids in overflow stream	ppm	150-250	150-250

### Circuit Description

The pyrite concentrate and tailings exiting their respective CIP circuits each transit into a dedicated pump box fitted with variable speed drives (one operating, one stand-by per duty).

The flows then enter their respective thickener feed box and reach the thickener feedwell through a submerged feed pipe. An internal slurry dilution system is reducing the slurry density within the thickener feedwell. Flocculant is added along the feed pipe and/or into the feedwell to assist the thickening process and reduce the loss of solids into the overflow stream.

The design criteria presented in Table 17-9 yield thickener diameters of 24 m for the pyrite concentrate, as a high-compression unit, and of 34 m for the pyrite tailings, as a high-rate thickener. The conical section of the high-compression unit has a slope of 30° and a straight side wall height of 2.5 m (total height of 9.7 m) to afford a total retention time of 8 hours for the solids feed to the unit.

The rake mechanisms and underflow pump power are specified for an equivalent underflow slurry density, and associated viscosity, of 5% above the design target for the PFT tailings and 3% for the PCT tailings.

The overflow streams transit through separate pump boxes, equipped with their set of water pumps (one operated, one stand-by). With the slurry temperature rise expected from the operation of the regrinding mills and the resulting increased leaching activity of the sulphides that may arise from it, dilution water to the concentrate leach circuit is preferentially drawn from the cooler pyrite tailings pre-detoxification thickener overflow. Excess water from the pyrite concentrate thickener overflow tank, after dilution water to the head of the pyrite tails leach circuit, is overflowing to the cyanide-bearing process water tank, directly receiving the overflow of the pyrite tails thickener.



Each of the thickener underflow is extracted via centrifugal pumps, with one operated and one stand-by unit per thickener.

Instrumentation and controls are similar to those described for the base metals thickeners, under Section 17.2.5. As for these thickeners, the tanks are elevated and the periphery of the equipment, below the tanks, is enclosed with insulated cladding. Sump pumps are installed to reclaim spillage. A beam running the length of the equipment radius, above the access platform, allows for the installation of a chain block to move in and out heavy parts from the ground elevation to the platform and to the drive mechanism.

### 17.2.11 Gold Recovery Circuits

The gold recovery circuits are based on the processing of 21.5 tpd of loaded carbon, with 15 tpd coming from the pyrite concentrate CIP circuit and 6.5 t every day from the tailings'. An elution circuit for handling 24 tpd of carbon is specified.

#### Carbon Washing and Neutralization

Loaded carbon from the CIP circuits is transferred intermittently into the two acid wash vessels, each with a capacity of 12 tonnes. Carbon transport water drains from the acid wash tanks and returns to the carbon fines water tank.

A batch of 3% w/w hydrochloric acid solution is prepared in the acid wash mix tank by transferring concentrated acid and fresh water. This acid solution circulates in the column, washing the carbon to remove scale deposits at a flowrate of 2 bed volumes ("BV") per hour. The acid solution circulates for a nominal 1.5 hours and then partially reports to tailings, with the rest of the solution reused for the next wash along with a partial fresh make-up. After acid washing, a caustic solution is prepared in the dilute caustic tank by introducing a stock solution at 20% and diluting it to 3% w/w. The caustic solution is circulated through the acid wash vessels, to neutralize any acid remaining on the carbon. This solution also circulates through the carbon for a nominal 1.5 hours and then all reports to tailings. A rinsing stage with fresh water is then implemented for 1 hour, with this solution flushed to the pyrite concentrate leach circuit.

A carbon transfer pump, connected to each of the acid wash vessels, pumps the washed and neutralized carbon load to one of two parallel elution columns. Carbon transport water flows to the acid wash vessel to facilitate the loaded carbon transfer and drains from the bottom of the elution vessel back to the carbon water tank at the end of the transfer process. Spray water is added to the wash columns to remove carbon from the vessel walls.

## Carbon Stripping

Carbon elution, or stripping, is following the high-pressure Zadra process. It is initiated when a barren strip solution of 2% NaOH and 0.2% NaCN circulates at an elevated temperature and pressure through the two elution columns, arranged in a serial configuration, at a flow rate of 2 bed volumes per hour for 8 hours. Sequential stripping can be implemented, where the a single column is first submitted to stripping and, as the pregnant solution grade is decreasing, the second one is brought in-line to boost again the grade presented to the electrowinning (“EW”) circuit downstream, keeping the EW circuit efficiency higher for a longer period of time without changing the amperage of the EW cells.

The solution exits the elution column as pregnant solution (e.g. loaded strip solution). The recirculated strip solution flows through a heat exchanger, which contains hot water delivered by a natural gas water heater, to achieve the nominal strip solution temperature of 135°C.

In another heat exchanger, the barren solution flows through one side and the pregnant solution, exiting the last elution column in the active strip circuit, through the other side. The exchanger then pre-heats the barren solution and cools down the pregnant solution, before being presented to EW. A pressure control valve on the pregnant solution line maintains the column at a nominal pressure of 650 kPa to ensure that the strip solution does not boil.

The stripping solution circulates in a continuous loop throughout the duration of the stripping sequence, first exiting the barren solution tank and passing through heat exchangers to pre-heat the solution as it enters the elution columns. From there the stripping solution, having been converted from barren to pregnant solution, is partially cooled through heat exchangers before reaching the EW circuit. Then, the solution changes from pregnant to barren again and is returned to the barren solution tank for entering the stripping loop again. The barren solution tank is sized to hold 5 BV of solution, equivalent to 120 m<sup>3</sup> for the design 12 t of carbon stripping capacity per elution column.

After a carbon strip is complete, transport water flows through the elution columns and a pump transfers the stripped carbon to a vibrating circular dewatering screen. The undersize fraction from the carbon dewatering screen reports to the carbon water tank and the oversize reports to the carbon regeneration kiln feed hopper.

## Carbon Regeneration and Fines Handling

A natural gas-fired carbon reactivation kiln regenerates the stripped carbon. The reactivation kiln, sized to handle 24 tonnes of carbon per day (1,000 kg/h) operates at a nominal temperature of 750°C and heats the carbon for 15 minutes. During reactivation, organic materials accumulated on the carbon are burnt off. After reactivation, the carbon activity is near its original level.

The kiln discharge reports to a quench tank, cooling the carbon under water to prevent it from burning and losing its metal adsorption capability.

Fresh carbon, to make up for attrition losses in the system as carbon fines, enters through a carbon attrition tank. Fresh attrited carbon and regenerated carbon pass through a sizing screen. Undersize reports to the carbon water tank. Oversized carbon reports to the carbon holding tanks following the quench tanks; one is holding the equivalent carbon inventory for a pyrite concentrate CIP tank (15 t) and the other the inventory for a pyrite tails CIP tank (6.5 t). A recessed impeller pump below each holding tank returns activated carbon to the appropriate CIP circuit, with cyanide-bearing water as the carrying medium.

The carbon water tank has two sections; on the inlet side, carbon fines settle and clear water overflows to the outlet side. A pump moves carbon transport water from the outlet side to wherever it is required. Transfer pumps periodically transfer the settled carbon fines slurry to a plate-and-frame filter press for dewatering. The filter press cake is bagged in tote bags and transported off site once sufficient inventory has built up. The fines are sold to a third party for recovery of the metal values contained in the carbon. The carbon fines filter press filtrate returns to the carbon water tank.

### Electrowinning and Gold Casting

Three parallel trains, of two EW cells each, recover gold and silver from the pregnant strip solution. The solution exiting the cells reports to the EW cell discharge tank and is pumped to the barren stripping solution tank. Each EW cell is equipped with a rectifier to supply DC current and control the electrical amperage provided to the cells.

The EW cells are fitted with stainless steel anodes and stainless steel wool cathodes. A direct current passes through the cells between the electrodes and causes the gold and silver in the solution to plate out onto the cathodes as a loose sludge.

Most of the gold-bearing sludge drops to the bottom of the EW cells. High pressure wash water blasting removes the sludge sticking to the cathodes surface. A sludge plate-and-frame filter press removes excess moisture from the gold sludge, which is then placed into a drying tray oven. The filtrate reports to the cathode wash pump box and is recycled as the source of the high pressure wash water, or as carbon transport water.

Fluxes are mixed with the dried and cooled EW sludge and the mixture is charged to the electric induction smelting furnace. The gold and silver doré is poured from the furnace into moulds arranged in a cascade on a trolley. The doré bars are allowed to cool in the vault before being cleaned, marked, and weighed. They are returned to the vault, awaiting shipment to an off-site facility for further refining. At the average head grades and projected recoveries per circuit, the sludge is expected to carry 8% gold and 77% silver; the remaining as impurities. The slag is recovered, cooled and crushed before being presented to a gravity table for recovery of gold-

bearing particles, to be added to the next pour. The table rejects are brought at the SAG mill sump pump to be reinserted into the circuit.

The refining area and gold room are secure areas with two controlled entrances. The first is a personnel entrance to the gold room office. This personnel entrance consists of a reinforced security door that leads into a staging room. The staging room in turn leads into the gold room through another reinforced security door, which can only be opened when the first security door is sealed. The second entrance is provided for the armoured truck to gain access the gold room.

Fume extraction equipment removes noxious gases from the EW cells and smelting furnace and precipitates the contaminants into an alkaline scrubbing solution that is recycled to the pyrite concentrate CIP circuit feed. No mercury retorting facilities are included.

#### 17.2.12 Cyanide Destruction Circuits

Two parallel cyanide destruction (“CND”), or detoxification circuits treat the respective thickened CIP circuit tailings. Cyanide destruction is completed using Caro’s acid, generated by reacting hydrogen peroxide and sulphuric acid together. The cyanide destruction circuit is located next to and outside of the process plant.

For each of the two circuits, cyanide destruction occurs in one tank providing a retention time of 30 minutes per circuit. This criterion indicates approximate tank dimensions of Ø7 m X 7.4 m high for the pyrite concentrate and Ø7 m X 8.5 m high for the pyrite tails.

Slurry overflows from the cyanide destruction tank into a pump box where a pump transfers each of the treated tails to an agitated stock tank, with one provided for each detoxified slurry stream. Slaked lime addition controls the pH in each tank. An agitator in each tank ensures vigorous mixing. An on-line measurement of the weak acid dissociable cyanide (“CNwad”) in the slurry entering and exiting the tanks is monitored. In the event of a high level of CNwad exiting the cyanide destruction tank, Caro’s acid will be added to the cyanide destruction discharge pump box to stabilise the CNwad levels. For the pyrite concentrate system, sulphuric acid addition is also made in order to reduce the residual level of ferrocyanates encountered.

The agitated tanks are sized to provide a retention time of 3 hours of live capacity, under design flowrate. Live capacity is calculated as the available volume above the minimum level at which the tank agitator cannot be operated, evaluated as 30% of the tank height. These criteria indicate tank sizing of Ø13 m X 15.6 m high for the pyrite concentrate and Ø13 m X 17.2 m high for the pyrite tails stock tanks.

The treated streams are then pumped either to the paste backfill plant preparation or as hydraulic fill to the mined voids available in the historical underground mine workings of the former Horne and Quemont mines. In Year 3, a TMF dedicated to receiving each of the detoxified products will replace the hydraulic fill option. A more detailed description of the paste backfill plant can be found below.

### 17.2.13 Paste Backfill Circuit

The paste plant described in Section 16.8 is split over several levels, allowing a gravity-fed system with the filter presses installed at the highest elevation. Beneath the filters, the filter cake conveyors are installed, feeding onto belt feeders via their respective hoppers. Each belt feeder discharges on a scale conveyor prior to feeding its respective paste mixer.

The paste backfill plant is equipped with one binder silo containing a blend of cement and slag that discharges through two rotary valves, one valve per paste mixer. The binder discharges on a scale conveyor (one per line) in order to control the binder's addition then onto a screw feeder to the paste mixer feed chute.

The paste mixer discharge hopper is in an elevated position above the ground level, such that it can feed the boreholes by gravity. It is to note that the layout takes into consideration the installation of a higher volume paste hopper in order to feed a positive displacement pump if required in the future. The ground level also includes sump pumps.

Since the paste backfill plant is part of the mineral processing plant and is located adjacent to the flotation area, the electrical rooms are combined with those of the rest of the process plant. The plant building is entirely covered and insulated to accommodate the cold weather experienced at the site. Room in the paste backfill plant is provided to allow for filter press maintenance.



Figure 17-13: Isometric view of the paste backfill plant

### 17.2.14 Reagent Systems

Typically, each system where bulk delivery of a liquid reagent is expected has a reception tank capable of holding approximately 1.5 truckloads. If the liquid reagent requires dilution, or if it is received at site in a solid form requiring dissolution, an agitated mixing tank is provided with batch controllers used to mix to the required reagent concentration. The mixing tank is typically sized so that one batch per day is prepared, therefore each tank holds about 24 hours of consumption at the design addition rates.

The last tank in each reagent system is the distribution tank. Metering pumps or, in the case of lime and cyanide, pumps feeding a pressurized distribution loop, are connected to these tanks. The pumps are used to reach all the addition points. The distribution tank typically holds 1.5 times the volume of the associated mixing tank, permitting sufficient time for proper reagent mixing or dissolution and transfer into the distribution tank. The liquid reagent tanks are contained in bermed areas of sufficient volume to handle the full volume in case of a vessel failure. Non-compatible reagents have individually bunded areas in order to ensure physical separation at the sumps level.

A pair of pumps (one operating/one standby) is provided to transfer solution from the holding tank to the mixing and/or distribution tanks. The pumps on the pressurized distribution loops are also provided in pairs with on-line backup. For systems fitted with metering pumps, each addition point has a dedicated pump, with an extra pump provided as a common standby unit.

A summary of the expected form of supply and mixing systems for each reagent is provided in Table 17-10.

**Table 17-10: Reagent mixing systems**

Reagent	Delivery	Mixing
Pyrite collector (PAX)	Tote bags	Mixing tank, water addition
Gold collector (R208)	Drums	Mixing tank, water addition
Cu/Zn collector (SIPX)	Tote bags	Mixing tank, water addition
Copper sulphate	Tote bags	Mixing tank, water addition
Lime	Trucks ~ solids	Detention-type slaker
Frother (MIBC)	Isotainer ~ liquid	Neat
Antiscalant	Isotainer ~ liquid	Neat
Cyanide	Isotainer ~ solids	Mixing tank, water addition.
Sulphuric acid	Tanker truck	Dilution tank, water addition
Hydrogen peroxide	Tanker truck	Dilution tank, water addition
Hydrochloric acid	Isotainer ~ liquid	Mixing tank, water addition
Sodium hydroxide	Tanker truck	Dilution tank, water addition
Flocculant	Tote bags ~ free flowing solids	Eductor, wetting head, mix tank. In-line mixer after metering pump for additional dilution

Lime and the flocculant mixing systems are exceptions to the typical reagent circuit configuration described above. The alternate system designs are described below instead, along with details specific to each reagent system.

### **SIPX – Copper and Zinc Collector**

SIPX is supplied in pellet form, packaged in 850 kg tote bags. A solution of 10% w/w is prepared in a dedicated facility. The SIPX addition system consists of a mixing tank and a holding tank. Small variable-speed dosing pumps connected to the holding tank feed controlled reagent volumes to the addition points.

Vapour extraction and scrubbing is provided to remove possible accumulation of H<sub>2</sub>S gas from the work environment.

### **Aerofloat R208 – Gold Collector**

R208 is supplied as a liquid, packaged in 1 m<sup>3</sup> totes. A solution of 10% w/w is prepared in a dedicated facility. The R208 addition system consists of a mixing tank and a holding tank. Small variable-speed dosing pumps connected to the holding tank feed controlled reagent volumes to the addition points.

### **Copper Sulphate – Zinc Activator**

Copper sulphate is supplied in pellet form, packaged in 1150 kg tote bags. A solution of 10% w/w is prepared in a dedicated facility. The copper sulphate addition system consists of a mixing tank and a holding tank. Variable-speed dosing pumps connected to the holding tank feed controlled reagent volumes to the addition points.

### **PAX – Pyrite Collector**

The delivery characteristics and system for this reagent are similar to the ones used for SIPX, with the tote bags of a 950 kg capacity.

### **MIBC – Frother**

Frother is supplied in liquid form in 1 m<sup>3</sup> tote bins. A tote is placed within the plant, above the flotation circuit, from which small variable speed dosing pumps are used to feed controlled volumes to each addition point.



## Flocculant

A single flocculant preparation system services the flotation concentrates, pre and post-leach thickeners, for both the pyrite flotation concentrate and tails.

Flocculant is delivered as a free-flowing powder in 750 kg lined tote bags. The flocculant preparation system consists of a dry flocculant hopper followed by a polymer screw conveyor and blower-eductor that transfers measured amounts of powder through a wetting head that mixes the powder with water to ensure blending of this viscous product. The product then enters an agitated mixing tank for maturing of the polymer mixture.

The mixing system is sized to complete a batch per 90 minutes (with 60 minutes of agitated curing) at an equivalent utilization rate suited to the design consumption requirements. The flocculant mixing system is a complete vendor-supplied package.

The mixing tank is paired with a much larger distribution tank that holds the 12 h design consumption at the 0.5% w/w flocculant strength.

The flocculant solution is delivered to each addition point by a dedicated progressive cavity pump that does not damage the polymer chains of the flocculant. In-line dilution is used to further dilute the flocculant solution down to 0.05% w/w solution strength prior to reaching the various addition points.

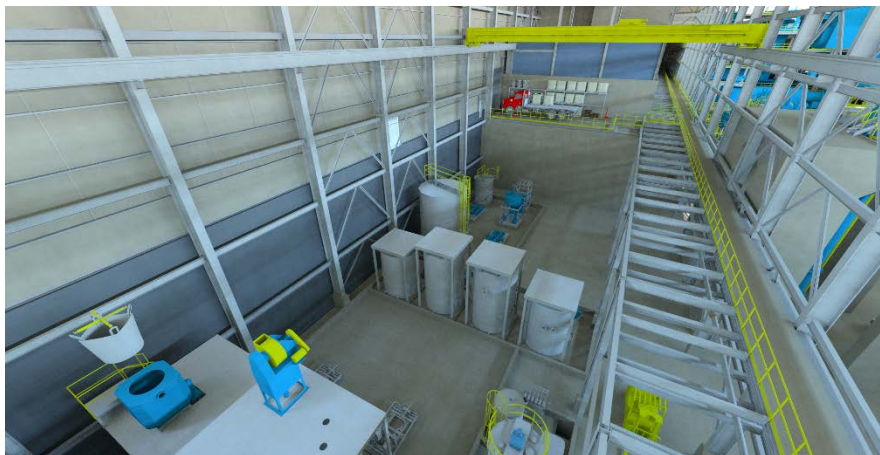

Figure 17-14: Batching reagents area



## Quicklime

A quicklime supply of 90% available CaO is expected. This is delivered via trucks to a 575 t silo providing an on-site inventory for three days of design consumption. The lime silo is fitted with a live bottom feeder and a vibrated dust baghouse.

The packaged slaking facility generates an 18% w/w quicklime solution at a design rate of 8 tph and a utilization rate of 75% to meet the design production rate. A rotary valve delivers the quicklime onto a volumetric feeder, metering the solids to a transfer screw conveyor and into the slaker.

The slaking is performed in two parallel detention-type slakers, using the resulting temperature elevation arising when quicklime is mixed with water to complete the slaking process. A temperature control loop and timers in the batch controller ensure the efficiency of the process.

The lime slurry exiting the slakers flows into a distribution tank where the solution strength is adjusted through dilution with water to 18% w/w and quenching of the slaked slurry also occurs. The lime slurry gravitates from the slakers to a mechanically agitated distribution. Two distribution loops are implemented from this tank: one for the grinding and flotation circuits, and one for the leach circuits, CND and gold plant requirements.

A constant supply of lime is provided to each of the closed-loop pressurized lime distribution networks via one operating and one standby pump connected to the distribution tank. The distribution network reaches all of the individual addition points. At the addition points, control valves with timed on/off openings allow for control and metering of the lime slurry. The distribution pumps pump at three times the design consumption flow, ensuring that sufficient velocity is maintained throughout the system, even under high withdrawal rates at the addition points, to prevent settling in the piping system.

## Sodium Cyanide

Cyanide is delivered to site in the form of briquettes, with a built-in alkaline buffer. The alkaline buffer reduces the purity of the cyanide to 97%. Cyanide is provided in 17.3 t reusable isotainers. This system is preferred for the delivery of a solution because it minimizes the number of trucks required and eliminates the possibility of a liquid spill.

The isotainer is deposited on a cradle and the contents are moistened by a closed-loop recirculation between it and the mixing tank. Each batch dissolves one complete isotainer to a 23% w/w cyanide solution.

The cyanide solution is metered with pumps to the addition points at the feed distributor of the leach circuits and to the elution circuit.

### Activated Carbon

Activated carbon is received in 500 kg bulk bags, nominally with size specifications of 8 x 12 mesh. The bags are unloaded into a hopper over the carbon attrition tank. Carbon fines overflow into the carbon water tank. New carbon that has passed through attrition is screened to remove any fines generated prior to entering the carbon holding tank. New carbon and regenerated carbon is combined at the carbon sizing screen.

### Hydrochloric Acid

Hydrochloric acid is received as a 32%-strength solution in isotainer and stored in a storage tank. The acid is pumped to the acid wash mix tank as required to make up a 3% solution in water, for acid washing carbon.

### Oxygen

Oxygen is delivered to site in tanker trucks. The liquid oxygen is stored in three 50 t tanks. From there it is metered as a gas to the addition points within the concentrate leach circuit with inertial flow meters and control valves.

### Sulphuric Acid

Sulphuric acid is received as 93% w/w high-strength solution by 30 t tanker trucks. It is put into a holding tank, from which it is fed to a day tank, without dilution. Metering pumps connected to these tanks deliver the acid as needed to the CND and the detoxified pyrite concentrate stock tank, as needed.

### Hydrogen Peroxide

Peroxide is received as 70% w/w high-strength solution by tanker trucks. The handling and distribution systems are as for the sulphuric acid, except for the absence of an addition to the pyrite concentrate stock tank.

### Caustic Soda

Caustic soda is used in the acid wash and elution columns. A small amount is used as scrubbing fluid and for pH control in the reagent mixing area. Caustic soda is received as a 30% solution in tanker trucks and put in a holding tank. It is then diluted to 20%. Upon transfer to the neutralization tank, it is further diluted to 3%, while the caustic sent to the barren strip solution tank is diluted to 1%. Metering pumps tied to the mixing tank deliver the caustic solution as scrubbing fluid to the other addition points.

## Antiscalant

Scale inhibitor is delivered in liquid form in 1 m<sup>3</sup> tote bins. One duty and one standby dosing pump, connected to a header linked to a pair of totes sitting on a steel frame, deliver this solution to the process and fresh water distribution tanks.

### 17.2.15 Process Plant Control System

#### Operating Philosophy

The operating philosophy for the processing circuits is based on the following fundamental concepts:

- The overall supervisory plant control is from a central control room where a senior operator can control all the systems and from where trouble-shooting by metallurgical staff can be facilitated by looking at on-line trended data.
- Various areas are equipped with closed-circuit television (“CCTV”) cameras, with panning and zooming capabilities, especially at the SAG mill feeders discharge transfer points to conveyors.
- The plant is highly automated and instrumented.
- Local slave consoles at strategic locations on the plant floor are used to provide a window for operators in the field to check operational data and locally start/stop individual equipment during shutdown and start-up of the plant or of one of the individual processing lines.
- There are few operators on the plant floor. Their main function is to provide confirmation of correct operating conditions, detect problems, make equipment checks, and do house-cleaning chores.

A generic description of the proposed control system topology is presented in Figure 17-15.

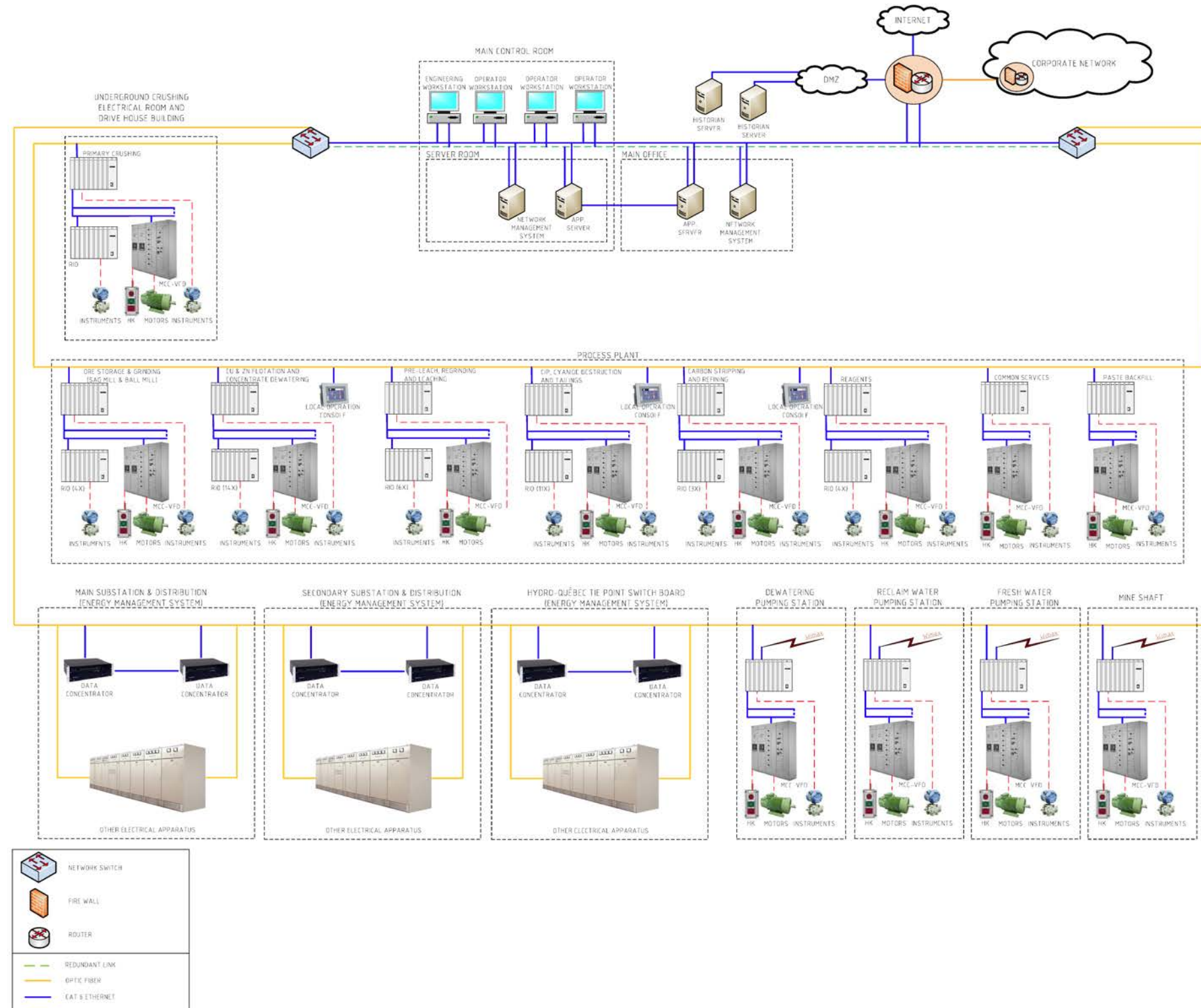

Figure 17-15: Proces plant control system generic topology

## Control System Topology

The overall plant operations will be supervised and controlled by a common industrial Process Control System (“PCS”) platform, enhancing the handling of analog inputs and manipulation through calculation and interfacing with an expert system, while enabling fast exchange of digital data used for motor protection and status and handling sequences and batch operations.

Main Process controller cabinets will be located inside the different electrical rooms. Local Remote I/O panels will be installed in the field process area.

The main site electrical substation, as well as those at the satellite operations, feeds control data to the related control rooms. The main communication backbone is provided by redundant Ethernet fibre optic cables.

Where equipment is supplied as a packaged unit, the vendor packages have standardized process controllers that communicate with and are controlled by the plant network. The only functions provided internally to the Process controller from the vendor are limited to protection devices monitoring with associated alarm trigger and fail-safe mode programmed at the vendor factory.

Ethernet network is used for interfacing electrical equipment.

The control system includes an operator workstation with historian software to enable reporting of plant data, calculations, statistical analysis of process data, and to enhance the metallurgical development capability of the plant operations.

A Process control system with open architecture is used where activities such as control of the process, connections to external systems, input/output (“I/O”) and field bus connections, information management, maintenance, and engineering configuration reside in one platform.

The control system has the functionality to manage and store historical variables such as run-time for equipment and operating variables for processes.

An information system and an information management system allow certain staff to monitor the process and the variables from their PCs connected to the management information platform.

The control system is divided into three zones:

1. Field – The sensors and signal transmitters are installed in the field. The transmitters are typically provided with local indicators mounted close to the equipment. A remote IO cabinet is installed in the field to interface all local sensors and signal transmitters. The major equipment is supplied with all instrumentation necessary for correct operation. In general, a dedicated process controller is supplied with open protocol to interface with the plant-wide data network. Such dedicated process controllers are delivered pre-programmed by the vendor and are responsible for managing electrical interlocks and services for major equipment with the capability to accept remote setpoints from the plant network.
2. Electrical Rooms – The process controller cabinet is installed in the electrical rooms with communication cards that interface with the PCS servers, Remote I/O cabinets, Motor Control Centers (“MCC”) and the electrical systems.
3. Control Room – The plant is monitored and controlled from the control room and strategic field locations at critical circuits. The latest-generation operating consoles are installed in the control rooms while the field stations feature less complex but more robust hardware to withstand the wet and dusty plant environment and vibrations. The screens display process graphics (mimics, trends, status, data, historic files, and alarms).

Monitors are installed for the CCTV system, a calling and searching system, fire protection system, centralized panel, and other dedicated systems that require monitoring or controlling by the operator.

Communications between the various parts of the system are via a system of interconnected networks, as follows:

- Operating Network – Based on Ethernet TCP/IP, minimum 100 mbps with a redundant configuration. This network provides the flow of information between the operator stations and the servers.
- Process Control Network – Based on Ethernet TCP/IP, minimum 100 mbps, that interconnects the Process controllers allowing interconnection between controllers and the interchange of information between the servers and the process.
- Field Bus – Ethernet Modbus TCP/IP, minimum 100 mbps, or similar, is used to interconnect the processors with motor starters and variable frequency drives. Modbus or DNP3 protocol is used to interface power monitoring devices and protection relays.
- Information and Operation Management Network – The control system is able to communicate with the plant network based on a standard Ethernet TCP/IP that is used to interchange and/or monitor information on PCs connected to the corporate network.



### 17.2.16 Process Plant Support Services

The process plant houses various dedicated facilities. In particular, maintenance shops for mechanical, electrical and instrumentation repairs are established within the paste plant, with availability for lifting devices within these premises. Elements requiring specialized maintenance or rebuilding work is dispatched to shops in the Abitibi area, or back to their suppliers.

A central control room houses human-machine interfaces (“HMI”) to interact with the control systems established throughout the plant. Video feeds from various cameras are displayed on monitors as well. Other HMIs are distributed in the plant to allow operators on the plant floor access to processing data.

An internal enclosure (divided into five working floors) houses the gold room, a metallurgical and sample preparation laboratory on one floor; change-rooms (dry) and cafeteria for plant employees on another floor; offices, conference and training rooms, staff cafeteria on the third floor; fourth and fifth floors are used as an electrical room and for the HVAC section.

Assaying will be performed on a contractual basis by a local third party laboratory.

## 17.3 Energy, Water and Consumable Requirements

### 17.3.1 Process Plant Electrical Distribution

The 25 kV main switchgear of GIS type (gas insulated switchgear) located in an electrical room between the main electrical substation and the grinding area, will distribute power throughout the mining complex. Most 25 kV feeders will supply transformers to step down the distribution voltage to useable 4.16 kV and 600 V voltage levels. There will also be dedicated feeders for the SAG mill, ball mill and HIG mills, Hoist room, headframe and underground electric distribution.

A secondary electrical room located in the recovery area has been planned to feed mechanical equipment and services within this area. This electrical room includes major electrical equipment such as 600 V transformers and unit substations, 600 V motor control centres and various variable frequency drives as requested by the process.

### 17.3.2 Energy Requirements

The electrical energy requirements for the processing plant were derived from the equipment list that provides expected motor sizes for all equipment and ancillaries. Each motorized item of equipment was assigned utilization, efficiency, and load factors to derive the data presented in Table 17-11.

Table 17-11: Indicated processing plant power demand, by area

Area	Description	Connected Load (kW)	Running Load (kW)	Average Efficiency Factor	Average Power Factor	Average Utilization Factor	Yearly Consumption (MWh) <sup>(1)</sup>
605	Ore Storage & Handling	635	501	0.94	0.89	0.77	4,389
610	Grinding	27,436	25,002	0.95	0.91	0.73	219,017
615	Flotation	6,213	4,299	0.94	0.87	0.79	37,659
616	Flotation Reagents	145	110	0.89	0.82	0.79	964
617	Concentrate Dewatering	787	451	0.92	0.85	0.74	3,951
620	Pre-leach thickening	1,700	877	0.95	0.87	0.74	7,682
625	Regrinding	15,916	15,610	0.93	0.90	0.85	136,743
630	Leaching	1,552	1,238	0.96	0.91	0.83	10,845
631	Oxygen Plant	2,322	1,470	0.93	0.88	0.73	12,877
635	Carbon in Pulp	2,141	1,207	0.95	0.87	0.75	10,573
640	Carbon Elution & Regeneration	378	201	0.92	0.87	0.72	1,760
645	Refining	374	273	0.93	0.88	0.73	2,391
650	Tailings Thickening	1,027	501	0.94	0.88	0.83	4,389
655	Cyanide Destruction	1,609	945	0.90	0.87	0.77	8,278
660	Tailings Storage & Pumping	512	337	0.90	0.83	0.77	2,952
665	Paste Backfill Plant	4,898	3,100	0.93	0.88	0.73	27,156
670	Reagent Handling and Distribution	1,084	698	0.90	0.82	0.77	6,114
675	Process Services	8,201	4,299	0.96	0.89	0.79	34,470
676	Process Plant Workshops	12	1	1	1	0.1	9
685	Plant Building Services	8,751	5,539	0.93	0.88	0.73	48,521
	<b>Total</b>	<b>77,492</b>	<b>66,659</b>	<b>-</b>	<b>-</b>	<b>-</b>	<b>580,740</b>

<sup>(1)</sup> Annual consumption based on a nominal throughput of 15,000 tpd.

In addition to electricity, a natural gas consumption of 2.76 Mm<sup>3</sup>/y is required to cover the needs for heating the carbon stripping solution, as well as for the carbon regeneration kiln. Another 3.54 Mm<sup>3</sup>/y is pegged for building air exchange heating.



### 17.3.3 Plant Water Systems

All water requirements at the plant, with the exception of water for human consumption and lavatories that is to be provided by a connection to the municipal network, are to be covered by recirculated process water originating from thickener overflows, augmented by treated mine dewatering water, surface water or reclaim water, once the tailings deposition facility will become available. These water sources are used as make-up process water and as the main source of fresh water.

Mine dewatering brings water from the active and historical mine workings recharge, as well as water recovered from the settling of hydraulic backfill brought into the latter. If needed, some or all of the pre-treatment steps used during the initial dewatering stage of the mine workings, then raising the quality of the discharge to meet environmental standards, would thus be applied.

The plant has three distinct process water systems:

- Process water: receiving water from the pre-leach and concentrate thickener overflows, filtrate from the paste backfill plant, as well as make-up from mine clarified water and (future) tailings pond reclaim system; services the needs in the grinding, concentrate dewatering and flotation circuits;
- Cyanide-bearing process water: receiving cyanide-laced water recovered from the overflow streams of the pre-detoxification thickeners; services the leaching and detoxification circuits with dilution water;
- Fresh water: receiving water from surface sources and (future) tailings pond reclaim; for uses such as carbon elution (acid wash, strip solution make-up and EW solution cooling), reagent preparation, equipment cooling and pump gland sealing.

Figure 17-16 presents a block diagram of the plant water balance. As previously stated, the process water systems have been divided into “cyanide-free” and “cyanide-bearing” circuits since introduction of cyanide to the flotation circuits would act as a gold depressant.

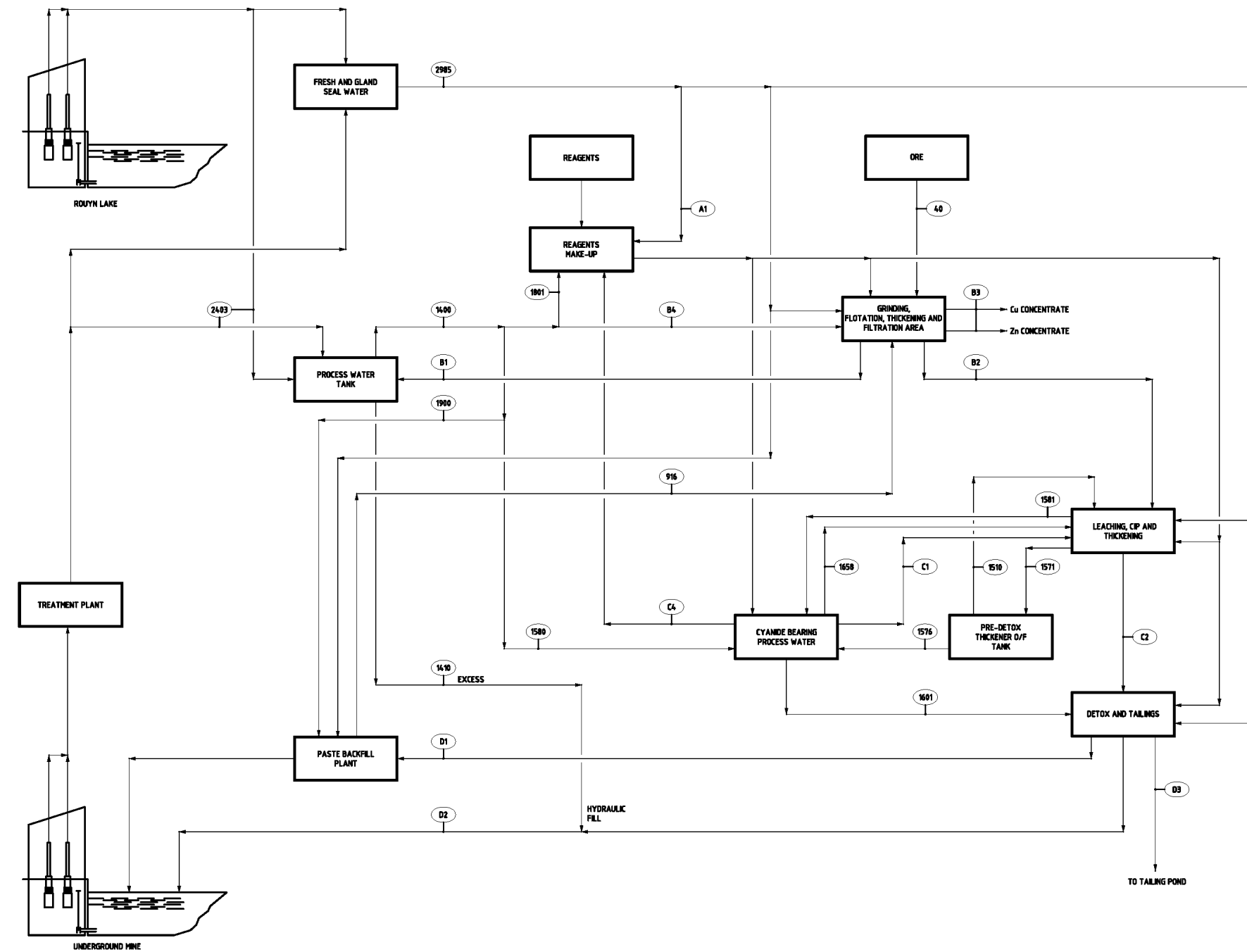

STREAM NO.	UNIT	A1	B1	B2	B3	B4	C1	C2	C4	D1	D2	D3	40	916	1400	1410	1510	1511	1516	1580	1581	1601	1658	1801	1900	2483	2985
CASE 1	l/m <sup>3</sup> of	859	38570	9244	34	32291	2788	17791	856	9502	2576	0	789	1548	38615	0	1231	610	183	347	2858	0	0	661	5321	45	5475
CASE 2	l/m <sup>3</sup> of	859	27023	9244	34	32291	2788	17791	856	0	12034	0	789	0	33272	0	1231	610	183	325	2079	0	0	661	0	6249	5297
CASE 3	l/m <sup>3</sup> of	859	27269	9080	34	32373	3400	12218	925	0	12487	0	789	0	33758	0	1041	7338	1766	729	1834	0	0	661	0	6489	5297
CASE 4	l/m <sup>3</sup> of	859	26771	9412	34	32288	2000	11954	785	0	11659	0	789	0	32863	0	1425	4856	547	0	2330	88	0	661	0	6892	5297
CASE 5	l/m <sup>3</sup> of	861	42176	10629	34	36997	3191	13589	985	9491	4405	0	908	1548	43627	0	1431	6967	1251	552	2376	0	0	763	5321	1451	5474

LEGEND  
 1- CASE 1 : NOMINAL THROUGHPUT WITH AVERAGE FEED GRADES, BACKFILL PLANT IS OPERATING.  
 2- CASE 2 : NOMINAL THROUGHPUT WITH AVERAGE FEED GRADES, BACKFILL PLANT IS OFF.  
 3- CASE 3 : DESIGN PYRITE CONCENTRATE PRODUCTION, BACKFILL PLANT IS OFF.  
 4- CASE 4 : DESIGN PYRITE TAILS PRODUCTION, BACKFILL PLANT IS OFF.  
 5- CASE 5 : DESIGN THROUGHPUT WITH AVERAGE FEED GRADES, BACKFILL PLANT IS OPERATING.

Figure 17-16: Process plant water balance

### 17.3.4 Air Systems

Air compressors for plant and instrumentation air, and low-pressure blowers are located in the service room near the flotation area.

Compressed air is delivered by compressors to the following areas:

- Ore reclaim tunnel;
- General plant usage, for instrumentation and maintenance tools;
- Concentrate and paste backfill filters, for diaphragm inflation and supply of cake drying air;
- Flotation cells and pyrite tails leach tanks, via low-pressure blowers.

### 17.3.5 Consumable Requirements

The main consumables for the processing plant are represented by the grinding media and liners for the SAG and ball mills, as well as the reagents used in the flotation, leaching, gold recovery and cyanide destruction circuits.

The grinding media consumption is based on the Bond theory, where unit consumption in g/kWh of grinding energy is related to the abrasion index of the ore. A discount for improved steel media metallurgy, from Bond’s era, is factored in. A parallel calculation is made using Molycop Tools software.

Using the average sulphur content to derive the related Ai from Figure 13-14, an Ai of 0.51 is used to calculate the SAG and ball mill media consumption presented in Table 17-12. For the regrinding duty, the consumption numbers presented are based on benchmarked data provided by the potential equipment vendor.

**Table 17-12: Estimated grinding media consumption**

Stage	Type	Size (mm)	Consumption		
			g/kWh	g/t	tpa <sup>(1)</sup>
SAG Milling	Forged Steel	125	76.9	869	6,675
Ball Milling	Forged Steel	50-63.5	75.7	1,225	6,064
Regrinding	Ceramic	2-2.5	10	439	1,148

<sup>(1)</sup> Annual consumption based on a nominal throughput of 15,000 tpd.

Table 17-13 lists the major reagents and summarizes the average consumption basis for each. Consumption rates are mostly based on results from bench-scale open and locked-cycle testwork conducted in 2015, 2016 and 2017. Antiscalant addition is estimated based on normal addition rates from the potential supplier’s technical datasheet.

Table 17-13: Reagents - used and indicated consumption

Reagent	Application and Addition Points	Consumption	
		(g/t)	(tpa) <sup>(5)</sup>
Sodium Isopropyl Xanthate (SIPX)	Collector in Cu, Zn flotation circuits	66	354
Potassium Amyl Xanthate (PAX)	Collector in pyrite flotation circuit	61	327
Aerofloat R208	Gold collector in Cu flotation circuit	26	139
Methyl Isobutyl Carbinol (MIBC)	Frother added to all flotation stages	109	589
Copper Sulphate (CuSO <sub>4</sub> )	Zinc activator, added in conditioning	266	1,437
Flocculant	For enhanced settling in thickeners and clear overflows To Cu concentrate thickener To Zn concentrate and Py tails pre-detox thickeners To pre-leach thickeners To Py concentrate pre-detox thickener	15 <sup>(1)</sup> 20 <sup>(1)</sup> 25 <sup>(1)</sup> 50 <sup>(1)</sup>	307
Quicklime (CaO)	pH modifier. Added to Cu and Zn flotation circuits Added to Py concentrate leach, CIP and CND circuits Added to Py tails leach, CIP and CND circuits	2,149 16,851 <sup>(2)</sup> 724 <sup>(2)</sup>	11,590 38,377 2,172
Sulphuric Acid (H <sub>2</sub> SO <sub>4</sub> )	For preparation of Caro's acid, for CND of: Py concentrate leach tails Py flotation tails leach tails	4,187 <sup>(2)</sup> 519 <sup>(2)</sup>	9,537 1,558
Hydrogen Peroxide (H <sub>2</sub> O <sub>2</sub> )	For preparation of Caro's acid, for CND Py concentrate leach tails Py flotation tails leach tails	998 <sup>(2)</sup> 190 <sup>(2)</sup>	2,274 571
Oxygen (O <sub>2</sub> )	Gold lixiviant. Added to Py concentrate leach tanks	1,196 <sup>(2)</sup>	2,725
Sodium Cyanide (NaCN)	Gold lixiviant Added to Py concentrate leach tanks Added to Py tails leach tanks Elution circuit barren solution tank	2,143 <sup>(2)</sup> 258 <sup>(2)</sup> 5	4,879 774 24
Activated Carbon (C)	Adsorption of gold. Added to barren carbon holding tank	40	216
Hydrochloric Acid (HCl) <sup>(3)</sup>	Carbon wash. Added to acid wash mix tank	265	1,429
Caustic Soda (NaOH) <sup>(3)</sup>	Carbon stripping/washing. Added to acid wash mix tank	296	1,595
Antiscalant <sup>(4)</sup>	Scale control. Added to process water systems distribution tanks and barren leach solution tank	15	82

(1) Flocculant consumption is based on the dry tonnage reporting to each thickener.

(2) Cyanide, lime, oxygen, sulphuric acid and hydrogen peroxide consumptions based on dry tonnes of feed to respective leach circuits.

(3) Hydrochloric acid and caustic soda used in elution circuit are based on tonnes of carbon processed.

(4) Antiscalant consumption is based on amount of new water moved in each circuit.

(5) Annual consumption based on a nominal throughput of 15,000 tpd.

## 17.4 Process Plant Personnel

A total of 89 workers are required in the process plant, including 35 salaried staff and 54 hourly workers divided into management and technical services, operations and maintenance departments. Table 17-14 and Table 17-15 present the salaried and the hourly manpower requirements, respectively, for the processing plant.

Table 17-14: Process plant salaried manpower

Tier #	General & Administration	Schedule	Number
<b>Operation</b>			<b>7</b>
10	Process plant Superintendent	5/2	1
2	Administrative Assistant	5/2	1
7	Production Foreman	5/4 Day & Night	4
6	Mechanical Project Engineer	5/2	1
<b>Maintenance</b>			<b>3</b>
10	Process plant Maintenance Superintendent	5/2	1
7	Mechanical Foreman	5/4 Day	1
6	Process plant Planner	5/2	1
<b>Electrical Department</b>			<b>10</b>
6	Electrical Engineer	5/2	1
7	Electrical Foreman	5/2	1
4	Instrumentation Technician	5/4 Day & Night	6
4	Network Technician	5/2	1
4	Automation Technician	5/2	1
<b>Metallurgy</b>			<b>15</b>
8	Senior Metallurgist	5/2	1
5	Metallurgist	5/2	4
4	Metallurgical Technician	5/4 Day & Night	8
4	Refinery Technician	5/4 Day	2
<b>Total</b>			<b>35</b>

Table 17-15: Process plant hourly manpower

Tier #	Hourly	Schedule	Number
<b>Operation</b>			<b>34</b>
22	Flotation Operator	5/4 Day & Night	4
22	Flotation Operator Helper	5/4 Day & Night	4
22	Filtration Operator	5/4 Day & Night	2
21	Reagent Preparation Operator	5/4 Day & Night	2
21	General Labourer	5/4 Day & Night	10
21	CIP-Elution Operator	5/4 Day & Night	4
23	Control Room Operator	5/4 Day & Night	4
21	Loader Operator	5/4 Day & Night	4
<b>Maintenance</b>			<b>16</b>
23	Industrial Mechanic	5/2	8
23	Industrial Mechanic	5/4 Day & Night	8
<b>Electrical Department</b>			<b>4</b>
23	Electrician	5/4 Day	4
<b>Total</b>			<b>54</b>
<b>Grand Total (salaried and hourly)</b>			<b>89</b>

## 17.5 Comments on Chapter 17

A series of testwork programs have been completed or were on-going concurrently with the production of this Report.

The overall flowsheet unit operations received attention, in terms of testing, for establishing appropriate design criteria. Feed grades, for copper, zinc and sulphur will all have some influence on the way the different circuits should be operated to provide optimum metallurgical efficiency. For this reason, short-term grade fluctuations should be minimized so as to allow the plant operations to reach an optimized steady-state valid over extended period of time, with minimal readjustment.

The following additional work and considerations are relevant to move the status of the process-related knowledge to the next level of development:

- Consideration for replacing the leach-CIP approach for CIL may yield capital cost savings, despite likely requiring a larger elution circuit. The fast leaching kinetics registered may limit this effect, coupled with having the first tank (following pre-oxidation on the concentrate circuit) operated as a leach unit only and loading carbon in the latter stages of both the pyrite concentrate and tailings circuits. Modelling work to compare the eventual efficiency of a CIL vs CIP approach completed in parallel with the preparation of this Report could be used to perform a trade-off study comparing both approaches.
- Delivery of MIBC and HCl by tanker trucks would result in price savings allowing to recoup the additional investment in holding tanks within a short period of time and result in on-going OPEX reductions.
- Reviewing the sizing of the primary grinding mills, while giving consideration to the final mine plan (v20) sulphur distribution, could indicate a reduction in the size of these units considering that the earlier mine plan used to derive the 80<sup>th</sup> sulphur percentile displayed an average sulphur content of 16.5% while the final mine plan is at 18.7%. This is thus indicating a softer average ore.

## 18. PROJECT INFRASTRUCTURE

*Pursuant to an agreement between Falco and a Third Party, Falco owns rights to the minerals located below 200 metres from the surface of mining concession CM-156PTB, where the Horne 5 deposit is located. Falco also owns certain surface rights surrounding the Quemont No. 2 shaft located on mining concession CM-243. Under the agreement, ownership of the mining concessions remains with the Third Party.*

*In order to access the Horne 5 Project, Falco must obtain one or more licenses from the Third Party, which may not be unreasonably withheld, but which may be subject to conditions that the Third Party may require in its sole discretion. These conditions may include the provision of a performance bond or other assurance to the Third Party and the indemnification of the Third Party by Falco. The agreement with the Third Party stipulates, among other things, that a license shall be subject to reasonable conditions which may include, among other things, that activities at Horne 5 will be subordinated to the current use of the surface lands and subject to priority, as established in such party's sole discretion, over such activities. Any license may provide for, among other things, access to and the right to use the infrastructure owned by the Third Party, including the Quemont No. 2 shaft (located on mining concession CM-243 held by such Third Party) and some specific underground infrastructure in the former Quemont and Horne mines.*

*Furthermore, Falco will have to acquire a number of rights of ways or other surface rights in order to construct the TMF and associated pipelines.*

*While Falco believes that it should be able to timely obtain the licenses from the Third Party and to acquire the required rights of way and other surface rights, there can be no assurance that any such license, rights of way or surface rights will be granted, or if granted will be on terms acceptable to Falco and in a timely manner.*

*Falco also notes that the timeline of activities described in this Report, and the estimated timing proposed for commencement and completion of such activities, is subject at all times to matters that are not within the exclusive control of Falco. These factors include the ability to obtain, and to obtain on terms acceptable to Falco, financing, governmental and other third party approvals, licenses, rights of way and surface rights (as described in this Chapter 18 and in Chapters 16 and 20).*

*Although Falco believes that it has taken reasonable measures to ensure proper title to its assets, there is no guarantee that title to any of assets will not be challenged or impugned.*

*The foregoing disclaimer hereby qualifies in its entirety the disclosure contained in this Chapter 18 of this Report.*



## 18.1 General

The Horne 5 Project surface infrastructure and services are designed to support the planned approximate 15,500 tpd LOM average production rate from the mine and will be based on the rehabilitation of some existing site buildings and on the construction of new buildings. Development of the future Horne 5 Mining Complex will occur on the former Quemont mine site while the surface tailings management facility, reclaim water pond, permanent water treatment plant and polishing pond will be located at the former Norbec tailings facility. The two sites will be connected by pipelines as can be seen in Figure 18-1.

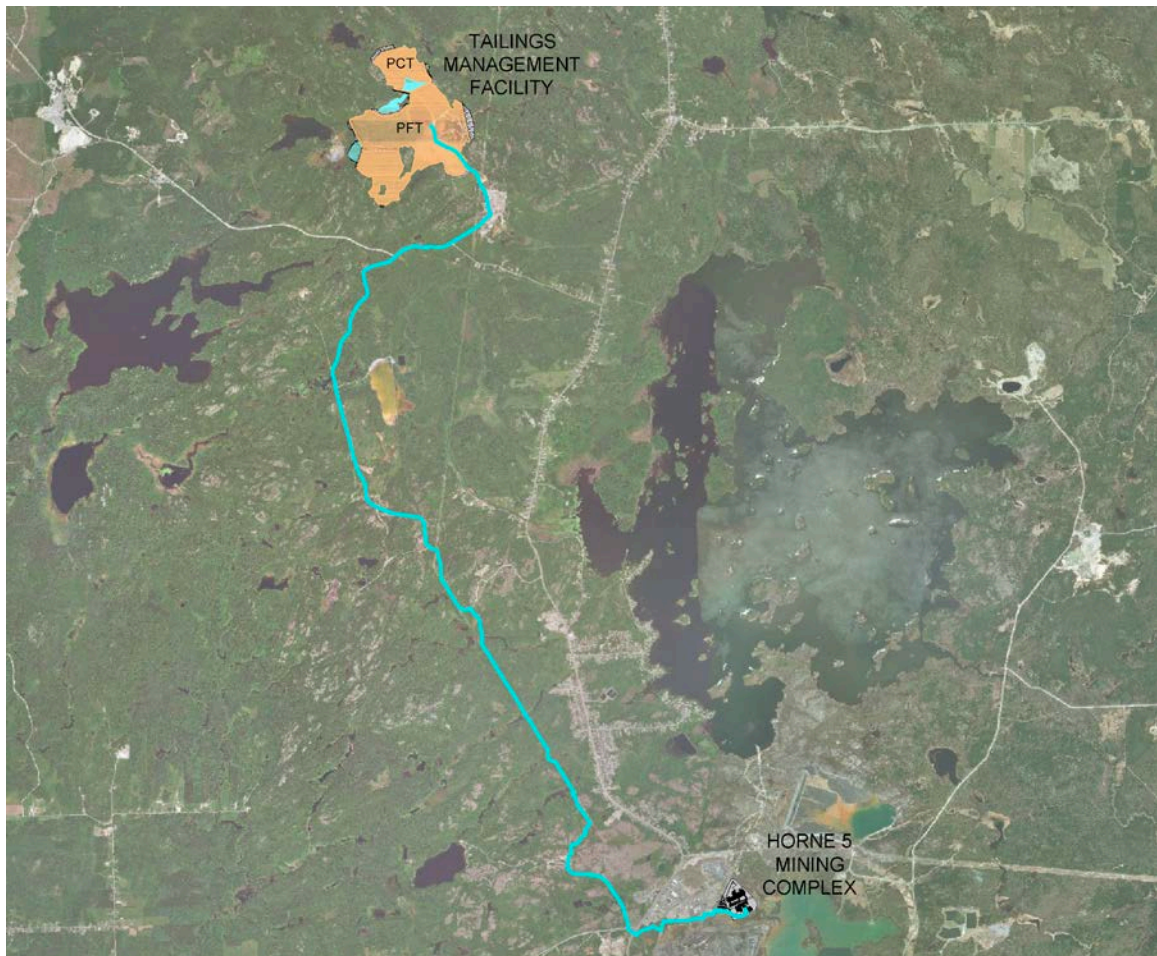

Figure 18-1: Project site overview including pipeline between the future Horne 5 Mining Complex and the TMF

The Horne 5 Project includes the construction of new infrastructure for the mining complex as well as community infrastructure including industrial and institutional relocation. The required infrastructure for the Horne 5 Project envisions construction of the following key items:

- Site access and site roads;
- On-site control gate house and parking area;
- 120 kV overhead transmission line from the Hydro-Québec Rouyn Noranda substation to the Project site (2 km);
- 120 kV to 25 kV Horne 5 outdoor main substation;
- Headframe, hoist room and surface material handling system;
- Process plant including paste backfill plant;
- Warehouse and service building (existing Sani-Tri building);
- Mine office and dry building (existing *Centre de Formation Quemont* building);
- First-Aid/Emergency services;
- Administration building (existing Lamothe building);
- Railway spur lines and siding storage tracks;
- Electrical distribution and communication infrastructure;
- Fuel storage;
- Site utilities;
- Community infrastructure (including industrial and institutional relocation);
- Surface tailings and water management facility infrastructure and pipelines;
- Water treatment facilities and slurry management pipelines;
- Fresh water pump house and pipelines.

## 18.2 Horne 5 Mining Complex Site Arrangement

The general site arrangement is presented in Figure 18-2, showing all of the site surface infrastructure at the Horne 5 Mining Complex.



Figure 18-2: General site layout drawing

## 18.3 Site Preparation

The site preparation activities include all drilling and blasting work, mass excavation and mass backfill for the process plant, headframe and hoist room, as well as levelling backfill around the administration building, and the mine building/dry. Excavated backfill from the process plant will be used to create the parking lot and a level pad to the south of the historical Quemont site buildings.

The head frame and hoist room will be constructed on bedrock, while the process plant and surrounding infrastructure will be constructed on engineering backfill.

## 18.4 Geotechnical Studies

### 18.4.1 Stratigraphy

The stratigraphy of the Horne 5 Mining Complex is showed in Figure 18-3.

During the geotechnical investigation, a layer of heterogeneous historically placed backfill of unknown origin (unit 1) with a thickness of 1.8 m to 15.2 m was encountered at the surface of the site. The upper part of this layer is usually composed of coarser particles under which usually lay a fine backfill layer composed of clay and silt, and possibly historical mine tailings. The characteristics of this layer suggest that the finer particles could be mine tailings from the former operations but this cannot be verified with certainty.

Underneath the backfill layer, the natural terrain is composed of a layer of cohesive soils (unit 2), with a thickness ranging from 0.8 m to 15.2 m. This layer appears to be present throughout the site. The presence of soils with a sensitivity ranging from “extra-sensitive” to “quick clay” was noted on this site. Sensitivity is defined as the ratio of intact to remoulded undrained shear strength. Clays with higher sensitivity classes are more prone to the occurrence of landslides.

Under the cohesive soils, a granular deposit (probability of till) (unit 3) is found, the thickness of which varies from 0.1 m to 10.7 m. This layer rests on the bedrock and appears to be present throughout the site.

The bedrock encountered on the site is either of the rhyolite type (from Quemont) from the formation of the Black River group (a volcanic magmatic rock, the volcanic equivalent of the granite) or of the diabase type (a plutonic magmatic rock, similar to the gabbro). The bedrock was encountered at depths varying from 3.2 m to 27.6 m.

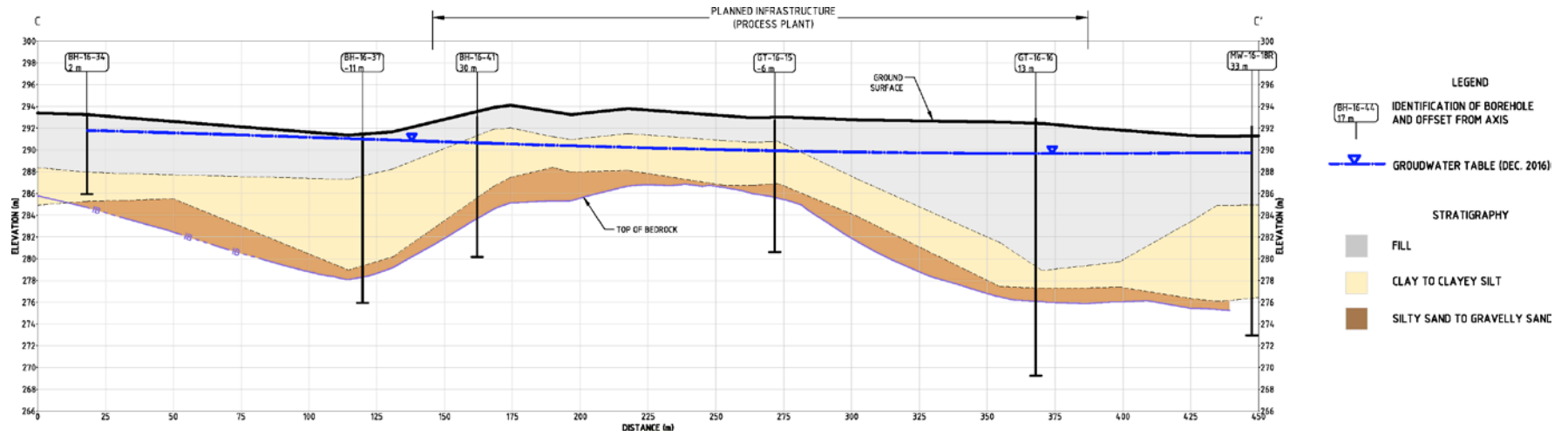

Figure 18-3: Typical cross-section showing stratigraphy



According to the tests carried out, the uniaxial compressive strength of the rock varies from 91.3 MPa to 180.6 MPa and the mean density of the rock is 2,731 kg/m<sup>3</sup>.

### Groundwater Level

The hydraulic head measured from the till and rock aquifer is between 0.5 m and 4.6 m below the ground surface.

#### 18.4.2 Proposed Structures and Types of Foundations

The main structures planned on site include the ore processing plant, head frame, hoist room, several thickeners and reservoirs located near the process plant, ore storage and transport structure located in the southeast portion of the site, and an electrical substation located north of the process plant.

Stratigraphy units 1 and 2 are planned to be excavated for the preparation of the foundations of the process plant. This excavation will provide a complete basement level throughout the entire process plant. In this basement, the process plant equipment would be installed directly on the surface of the rock, where possible, where the rock will become flush within the shallowest part of the excavation. The foundations of other equipment and of the part of subsoil not resting directly on the rock are intended to be built on a controlled granular backfill placed from the surface of the rock or the surface of the soil unit 3.

Tanks and thickeners are also assumed to rest on a controlled granular backfill from the rock surface or soil unit 3 after the full excavation of units 1 and 2.

#### 18.4.3 Foundation Design Recommendations

- The design bearing pressure for foundations supported directly on sound rock was estimated at 5,000 kPa for a settlement not exceeding 25 mm;
- The allowable bearing capacity was estimated at 9.5 Mpa for foundations supported directly on sound rock;
- For the design, the controlled backfill is assumed to reach an allowable bearing capacity of 300 kPa.

#### 18.4.4 Groundwater Control

The potential excavations are expected to reach a depth greater than that of the groundwater surface over the entire site, except at the site planned for the head frame and hoist room. Considering the presence of a granular backfill of unknown extent over the site, capable of acting as a water reservoir and of which the connection with the surrounding streams is not known, infiltration of important water volumes should be anticipated in the excavations.

## 18.5 Site Access Road and Control

The site access will be on Marcel-Baril Avenue, which will be modified to end at the control gate and parking lot of the future Horne 5 Mining Complex.

Site access control, including fencing, will be erected at the main entrance of the site to supervise the personnel entrance and merchandise transport. Security personnel will ensure visitor registration and make sure that all safety protocols are followed. Site access will be controlled using a comprehensive, industry-proven security access system. The system will include a network of cameras and card readers.

Furthermore, a fire protection system panel will be connected to the site access control building.

The dimensions of this building will be approximately 12 m by 9 m.

A parking lot with a capacity of 350 vehicles, including electrical outlets and lightning, will be built at the site entrance. A conceptual rendering of the control gate is shown in Figure 18-4.



Figure 18-4: Mining complex parking lot and site access control

## 18.6 Light Vehicle Roads

Existing roads are already in place for light vehicle access to the future site. These roads will be preserved and modified where needed in order to provide comprehensive access to planned surface infrastructure.

## 18.7 Electrical Infrastructure

### 18.7.1 Power Supply

Electricity will be supplied to the site at a voltage level of 120 kV originating in the nearby Hydro-Québec Rouyn-Noranda substation, approximately 2 km away. The proposed overhead line routing is shown in Figure 18-5.



Figure 18-5: Proposed overhead line from the Hydro-Québec Rouyn-Noranda substation to the Mining Complex

At the site, the outdoor substation will lower the incoming voltage (120 kV from Hydro-Québec) to 25 kV using two main transformers of 120-25 kV, 75/100/125 MVA each, for a combined firm power of 125 MVA. During normal operation, both transformers will share the loads, but during maintenance or repair work, one transformer will supply the entire plant load, thus increasing the overall electrical supply reliability.





Figure 18-6: 120 kV Outdoor substation isometric view

The output of the two main transformers will feed a 25 kV switchgear of “GIS” type (gas insulated switchgear) located in an electrical room within the process plant. This main switchgear will distribute power throughout the mining complex. Most 25 kV feeders supply transformers to further step down the distribution voltage to useable 4.16 kV and 600 V voltage levels. There will also be dedicated feeders for the SAG mill, ball mill and HIG mills, hoist room and underground electrical distribution. Considering the close proximity between buildings on the site, 25 kV power will be distributed using underground cables rather than overhead lines.

The largest motors are those of the SAG and ball mills, the regrind mills and two of the three mine hoists, accounting for half of the total site power demand. All of these equipment are controlled by variable frequency drives, and are configured to keep the harmonics generation within acceptable limits as per Hydro-Québec requirements.

### 18.7.2 Power Demand

The power demand of the overall Horne 5 Project is approximately 93 MW. The calculated power demand was derived from the mechanical and process equipment list without considering standby equipment and applying representative efficiency and load factors.

The following table shows the distribution of power by area/sector for the mining complex. The power demand at the TMF site and the fresh water pump house will use existing electrical lines at or near their respective sites, and not the main substation at the Horne 5 Mining Complex.

**Table 18-1: Power demand by area at the Horne 5 Mining Complex**

Area/Sector	Description	Connected Load (MW)	Power Demand (MW)
200	Underground Mine	10.5	5.9
300	Mine Surface Facilities	32.3	15.7
400	Electrical and Communication	0.5	0.25
500	Site Infrastructure	4.5	2.5
600	Process Plant	85.3	66.2
800	Tailings	1.2	0.8
--	Electrical network losses (2%)	-	1.8
	<b>Total</b>	<b>134.3</b>	<b>93.2</b>

### 18.7.3 Emergency Power

Two emergency diesel generator units (4.16 kV and 600 V) are planned for the purpose of supplying electricity to the critical process equipment/installations when the main power is lost. Both generators will be installed outdoors in a shelter near the 120 kV main substation as an emergency power source. Critical loads will be grouped into different categories where some will be started automatically (lighting and critical services) and others controlled manually.

In the process plant, the emergency power demand requirements and generation are as follows:

**Table 18-2: Process plant emergency power demand**

Voltage Level	Emergency Load (kW)	Power Generation (kW)
4.16 kV	2,200	2,000
600 V	3,815	2,000
<b>Total</b>	<b>6,015</b>	<b>4,000</b>

The emergency load requirements exceed the planned installed power generation as is typically the case. Therefore, an adequate starting and sequencing of critical loads program (PLC based) is planned to ensure that the installed back up power capacity is sufficient for the emergency load requirements.

For the mine auxiliary hoist, a 600 V generator, with a capacity of 2 MVA, is installed outdoors in a shelter complying with CSA C282 as an emergency power source. This generator is equipped with two breakers feeding two different automatic transfer switches, one of which is installed in the electrical room, while the other is installed in the auxiliary hoist fire resistance area of the hoist room. Transfer switches feed the emergency switchboard for general emergency loads and feed the MCC for the auxiliary hoist.

## 18.8 Hoist Room and Headframe

The hoisting plant at surface consists of the hoist building and the headframe. The headframe building and hoist building will be built where the historical Quemont No. 2 shaft and headframe were located as the former shaft will be used for production. The service and auxiliary hoists are located inside the hoist building while the production hoist is located at the top of the headframe.



Figure 18-7: Headframe and hoist room buildings

### 18.8.1 Hoisting System

The hoisting system for the Horne 5 Project consists of three different hoists to operate the two skips, the service cage and the auxiliary cage. The specifications and parameters for each hoist are presented in Table 18-3. The design of the hoisting system was realized in collaboration with a supplier to ensure the feasibility and performance of the hoisting system.

**Table 18-3: Mine hoist specifications**

Parameters	Production	Service	Auxiliary
Location	Headframe	Hoist Building	Hoist Building
Type	Friction	Double Drum	Single Drum
Configuration	Skip/Skip	Cage/Counterweight	Single Cage
Drum Diameter	6,500 mm	5,500 mm	3,050 mm
Rope Diameter	6 x 56 mm	54 mm	32 mm
Conveyance Tare Weight	43,000 kg	9,210 kg	1,925 kg
Conveyance Payload	43,000 kg	15,000 kg	1,250 kg
Conveyance Capacity	-	2 x 50 men	2 x 5 men
Motor Power	2 x 4,800 kW	2 x 1,000 kW	1,000 kW
Motor Type	Direct	Gearbox	Gearbox

The production hoist selected is a friction type, in a tower mounted configuration due to the large payload required to achieve the feed to the process plant. The hoisting capacity is 23,180 tpd in mine Phase 1 and 16,530 tpd in mine Phase 2. The use of a double drum hoist is not a viable option due to market availability of a rope with sufficient capacity. A Blair Multi-Rope hoist was a feasible option, but was a more expensive solution. The friction type hoist provided the greatest ability to meet the production requirements for the lowest cost.

Using a friction hoist in a deep shaft requires an important number of ropes and fitting the six ropes required in this application on top of the skips represents a challenge, especially using an existing shaft with fixed dimensions, thus, the ropes are offset by 150 mm from the centre of the skips in order to allow additional clearance for the attachments.

The rope configuration in the selected friction type hoist only allows operation on one level at a time with two skips, due to the presence of tail ropes under the conveyances. However, it is possible to operate one skip at a time at any station, which reduces the impact of this configuration. Good mine planning combined with a single skip operation makes the use of a friction type hoist feasible. Underground ore passes and crushing station locations were designed to hoist using two skips from one level during Phases 1 and 2 of the mine development.

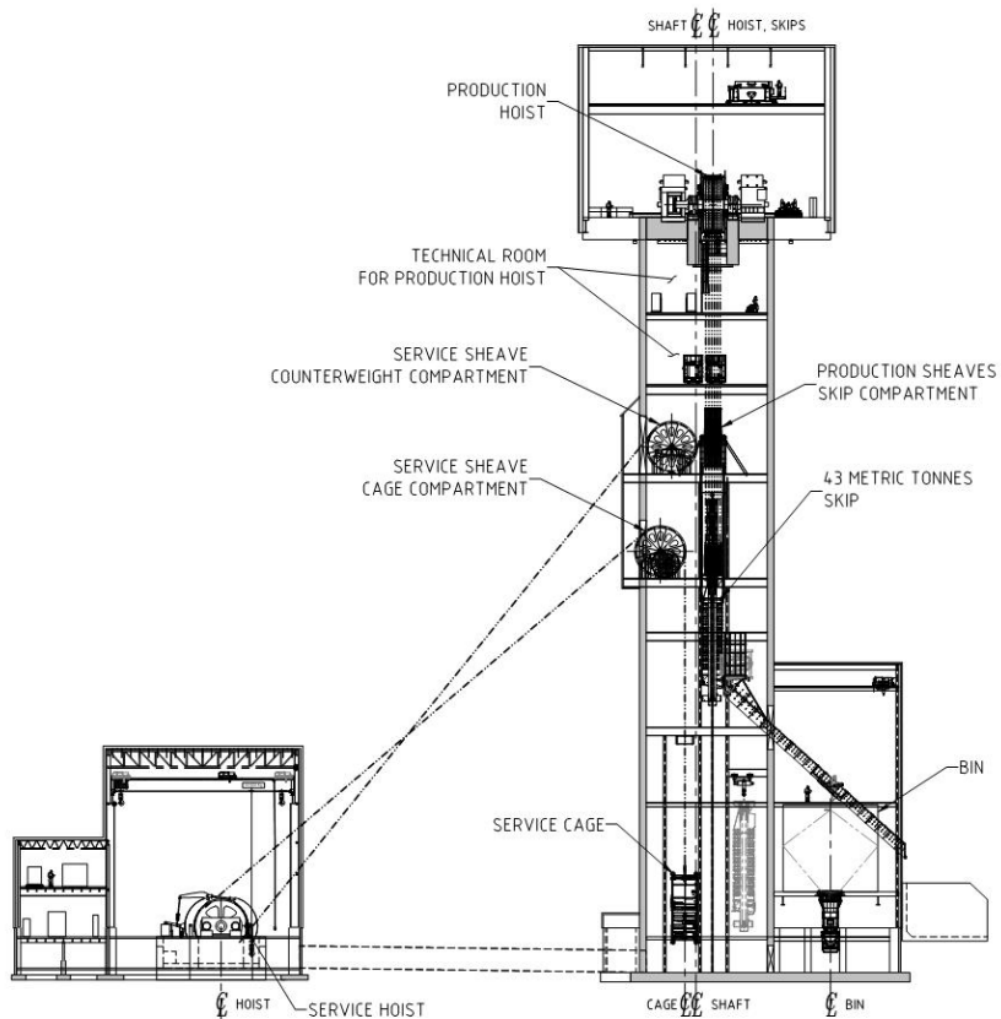

Figure 18-8: Hoisting system

The service hoist selected is a 5.5 m diameter double-drum type in a cage/counterweight configuration. This type of hoist is frequently used to operate mine service cages and doesn't have any major disadvantages. The cage capacity is set to 15,000 kg but it is possible to add additional capacity for major equipment handling by removing the cage.

The selected auxiliary hoist is a 3.048 m (10 ft) single drum type and is a typical installation for this application.

## 18.8.2 Hoist Building

The hoist building for the service and auxiliary hoists includes the main electrical room. The dimensions of the complete building are approximately 30 m x 36 m with a height of 18.5 m. The building is erected on concrete foundations directly on bedrock. The foundation includes a basement for maintenance and access to a service tunnel between the hoist building and the headframe. The hoist building is equipped with two overhead cranes, one for the service hoist (40 t) and another for the auxiliary hoist (15 t) installation and maintenance. The auxiliary and service hoists are separated by a fire resistant wall as required in Québec regulations.

The main electrical room has two floors. Transformers (all dry type), motor control centres (“MCCs”), 600 V panel boards and PLCs are installed on the first floor while the 25 kV and 13.8 kV switchgears are installed on the second floor.

The main electrical distribution within the hoist building is fed directly from the substation with two 25 kV feeders. The main 25 kV switchgear is a GIS type with a busbar capacity of 1250 A, two main breakers and one tie breaker to feed electrical distribution from only one main breaker in the event of a problem. All breakers in the 25 kV switchgear have a 1200 A breaker frame. This switchgear feeds the production hoist (located at the top of the headframe), the service hoist (located within the hoist building), the underground 13.8 kV distribution, and the 600 V distribution.

## 18.8.3 Underground Distribution

Underground distribution is powered by two 25 kV/13.8 kV, 15-20 kVA transformers through a 13.8 kV switchgear. The two transformers are located outdoors near the hoist building. The 600 V distribution is powered by one 25 kV/600 V, 2.5/3.3/4 MVA transformer through a 600 V switchgear. This switchgear feeds the MCCs and emergency switchboard. All the 600 V equipment are installed in the main electrical room within the hoist building, on the first floor.

## 18.8.4 Headframe

The headframe is composed of a 14.25 m x 16.25 m concrete slip form with a 16.25 m x 27.0 m steel penthouse on top. The slip form height is 80.3 m while the total headframe height is 100.3 m. A shaft house is located at ground level in front of the main doors for material and equipment handling. Annexes for the 300 t ore bin and a ventilation building are also located at ground level.

The headframe floors are designed to allow operation and maintenance of equipment. The main floors in the headframe are the following (from bottom to top):

- Dump floor;
- Service and auxiliary sheaves floor;
- Deflection sheaves floor;
- Power floor;
- Service floor;
- Hoist floor.

A few other floors and walkways are installed in the headframe for access and maintenance purposes.

The dump floor is designed to allow access for maintenance to the hydraulic dump system and the skip discharge chute. The sheaves floors support the sheave for all ropes as well as the crash floors for all conveyances. The power and the service floors are for the secondary electrical room within the headframe, which houses the 600 V MCCs, variable frequency drives, isolation and excitation transformers for the hoist motors. The production hoist is installed on concrete beams on top of the concrete slip form. The concrete beams will be built inside of steel beams after the shaft rehabilitation.

The headframe is equipped with a 60 t overhead crane at the top of the penthouse for hoist installation and maintenance. A 10 t overhead crane is installed in the bin house for maintenance. Two 50 t monorails are also installed for skip maintenance and other monorails are installed on the main floors for equipment handling and maintenance.

### 18.8.5 Surface Material Handling

The 300 t ore bin located in the building at the headframe bottom is used to feed the surface material handling conveyor to the stockpile via an apron feeder installed below the bin. The surface material handling system is designed for 1,300 tph to match the production rate of the hoisting system during Phase 1 of the underground mine. The conveyor inclination varies from 8° to 15° in order to reduce the required excavation while respecting the 86 m horizontal distance to the stockpile. The conveyor is oriented at 38° from the headframe to respect the site surface layout.



## 18.9 Process Plant

Two apron feeders will feed the SAG mill feed conveyor to supply the process plant with a fresh source of ore. The process plant ore feed storage will be partially underground and will be transported by conveyor to the process plant. The process plant will be located adjacent to the mine and administration buildings, on the north side of the site and will house the paste backfill plant and assay lab. The building will be 66 m wide x 235 m long, with a height of 32.5 m. An isometric view of the process plant is found in Figure 18-9.

The main processing building will house the grinding area (SAG and ball mills), flotation cells, regrind mills, CIP, carbon stripping, electrowinning, refining and reagent preparation areas, as well as the paste backfill plant, tailings pumps, process services, offices and metallurgical laboratory. The pre-leach thickeners, leach tanks, tailings thickeners, cyanide destruction tanks, lime, and paste backfill binder silos are to be located outside of the building.

The grinding area will contain the SAG mill and ball mill, sizing screen and cyclone cluster. This area will be serviced by two 60 t capacity overhead cranes to lift the heaviest process plant parts. The SAG and ball mill electrical rooms will be located on the operating floor. The control room will be located near the process plant offices on an elevated floor.

The flotation area will contain the flotation cells and will be serviced by one overhead crane. The concentrate loadout houses the thickeners, stock tanks as well as pressure filters for the copper and zinc concentrates alike. This area will be serviced by two 20 t capacity overhead cranes.

The gold recovery area will contain the regrind mills, CIP, carbon stripping, electrowinning, refining, and reagent preparation areas, as well as the paste backfill plant. This area will be serviced by two overhead cranes, one with a 40 t capacity and one with a 5 t capacity.

There will be two main building heating, ventilation, and air conditioning (“HVAC”) service rooms and two electrical room areas. In each case the HVAC rooms will be located on the floor above the electrical rooms. The first electrical room will be located above the mechanical and electrical shops in the grinding area at the northeast corner of the building. The other will be located next to the process plant offices on the southwest corner of the building. The gold room, operations/maintenance office staff, metallurgical laboratory, conference room, documentation room, computer server room, lunch room, washrooms, and change rooms will be located on the south-central side of the process plant. This area will be five floors high.

The paste backfill plant will be located within the process plant and will have a floor space of approximately 42 m by 43 m. The plant will consist of several levels in order to promote a gravity-fed system. Since the paste backfill plant is part of the mineral processing plant and is located adjacent to the flotation area, the electrical rooms will be combined with those of the rest of the process plant. Space in the paste backfill plant has been reserved to allow for maintenance of the filter presses.



The reagent storage area will be located in an engineered, membrane covered building, constructed next to the concentrator building. This area will contain all the chemical products required for the process with the exception of the daily reagent tanks, which will be located inside the main concentrator building.



Figure 18-9: Isometric view of the processing plant

### 18.10 Warehouse and Service Building

The service building will consist of the renovated portion of the existing Sani-Tri building, located to the south of the new hoist room. The service building will cover an area of approximately 420 m<sup>2</sup>, including a maintenance bay. The building will be used as a mechanical shop for the mine surface mechanics. The maintenance areas will also have access to a 5 t overhead crane. The warehouse will use a portion of the existing Sani-Tri building and will be renovated to serve its new purpose. It will cover an area of approximately 1,600 m<sup>2</sup>. Figure 18-10 shows an architectural rendering of the warehouse.



Figure 18-10: Warehouse

### 18.11 Mine Office and Dry Building

The existing Quemont building, currently sitting north of the proposed headframe location, will be re-purposed and modified to serve as the mine administration office and dry facility. The two-story (plus basement) building covers a surface area of 1,800 m<sup>2</sup>. Upgrades required for its new purpose will include the following:

- **Basement:** A tunnel connecting the basement of the mine dry and office building to the headframe will serve as the passageway by which workers can access the shaft. Additionally, the existing basement will be modified to provide space for the mine survey and rescue groups, training facilities and an electrical workshop;
- **Ground floor:** This floor is designed to house the men's mine dry facilities and changing rooms, which are projected to have a capacity for 350 workers as well as the women's mine dry facility and changing rooms (50-person capacity). The ground floor of the administration building is also designed to include a cafeteria and lunch room, mine offices, control room and an infirmary;
- **Top floor:** The upper floor is to be converted to hold approximately 50 offices, numerous conference/training rooms and toilet facilities.

The existing interior architecture as well as the mechanical and electrical systems will be replaced to accommodate the new arrangement.

The building will be renovated in order to meet the current codes and standards, as well as to meet Falco's esthetic criteria.

Figure 18-11 shows an architectural rendering of the mine office and dry building.



Figure 18-11: Mine office/dry building

## 18.12 First Aid / Emergency Services

The planned First Aid facilities will provide sanitary facilities, running water and will include all instruments, supplies and furniture necessary for the trained and qualified staff to give first aid. The facilities will be designed and operated as per the “*First-Aid Minimum Standards Regulation*” (Chapter A-3.001, r. 10). The room will be part of the mine office/dry building and will be located on the perimeter of the building to ensure direct access to the paramedic team. The first aid room will cover approximately 40 m<sup>2</sup>, including sanitary facilities.

There will also be a mine rescue room with all the necessary equipment. This room will be located in the basement of the mine office and dry building close to the tunnel giving access to the shaft and will cover approximately 130 m<sup>2</sup>.

## 18.13 Administration Building

The existing building, which is currently being used by Lamothe (a supplier of aggregate to the construction industry), will be converted as the site's administration offices. The renovations will be done ensuring the building meets current codes and standards, as well as adhere to Falco's criteria for esthetics. Figure 18-12 shows an architectural rendering of the administration building.



Figure 18-12: Administration building

## 18.14 Railways

In order to economically transport materials and reduce the carbon footprint of the Project, railway infrastructure was selected for the Horne 5 Project. Siding storage tracks will be built next to the existing Canadian National Railway Co. railroad, north of the site, and a spur line will connect the siding to the concentrate loadout area to transport concentrates leaving the site as well as deliver paste backfill binders delivered to the site.

The proposed railway infrastructure consists essentially of two distinct areas of train operations. The management (storage) area for inbound and outbound cars, located to the north of the site and a specific branch dedicated to connect the concentrate loadout area to the management area.

The inbound and outbound (storage) area consists of four tracks with a total storage capacity of 34 cars, a total of four turnouts (including the main turnout originating on the Canadian National Railway Co. main track) and 700 metres of single storage track. The platform of the tracks will be ballasted. All track material will be sized to 115# RE. The profile of the top of rail will be levelled. This area will be operated jointly by the Canadian National Railway Co. and Falco.

The branch linking the storage area and the plant consists of a 416 m siding track and two turnouts (including the turnout from the storage area). The track must cross a main water pipe with a railway bridge of approximately 20 m in length. The profile of the rail to the first switch is set at 1.22% and the profile of the rail at the entrance of the building is set at 0%. This zone will be operated by Falco only, using a mobile track unit.

## 18.15 Communications and IT

The Internet and phone services will be provided for the Horne 5 Project by a local Internet service provider.

A redundant fibre optic network will interconnect critical areas, including the following:

- Gate house;
- Administration offices;
- Mine offices;
- Process plant
- Underground communication system;
- Main electrical substation;
- Server room;
- Control room;
- Telecommunication services for non-critical, remote locations will be provided by a wireless network.

The fibre optic network will be shared between the following systems:

- Process plant control system (process control network and electrical systems);
- Corporate IT (phone and data);
- Computer OT (operation and maintenance network);
- Fire detection;
- Video surveillance and access control systems.

A mobile radio system will be deployed to the plant personnel and vehicles. The surface mobile radio system will be bridged with the underground mobile radio system.

### 18.16 Bulk Explosive Storage

Average explosives consumption for the Horne 5 Project is estimated at 54,000 kg per week. Bulk emulsion will be used given the urban setting. The explosives will be sent directly underground, thereby avoiding the supervision and temperature requirements associated with surface storage. The explosives will be brought underground in approved tote bins, using a service hoist and a dedicated compartment in the production shaft.

Two main underground powder and cap magazines were designed, each with a capacity of over 50,000 kg. One is located on main level L1194 for Phase 1 and the other on main level L1874 for Phase 2. The design meets regulatory requirements, which notably require powder and cap magazines to be:

- Located at a secure distance (60 m) from the shaft, stations, emergency exits, refuges and any potential fire hazard or potentially explosive sources (fuel bays or oil and lubricant storage site);
- Located at a minimum distance of 8 m from each other;
- Equipped with ventilation and fire suppression systems;
- Equipped with a decompression zone in front of the powder magazine.

### 18.17 Fuel Storage and Delivery

As mentioned in Section 16.5.3, the annual mobile equipment fuel consumption is estimated at approximately 4 ML/y. As per regulatory requirements, the pipes must be able to self-purge and the delivery of the fuel into the mine must be gravity-driven, in this case along a 2 in galvanized steel pipe in the Quemont No. 2 shaft. It is expected that 77,000 L will be delivered to the mine site each week. Assuming biweekly deliveries, the fuel surface tank must have a storage capacity of 40,000 L, and it must be equipped with spill-prevention features. Fuel will be sent underground in batches of 5,000 L, requiring the installation of two 5,000 L tanks, one on surface and the other near the underground fuel storage tank. Batch production will be fully automated, controlling the pumps that produce the batches.



## 18.18 Site Utilities

Several common site utilities such as natural gas, water, and sewage management have been designed for the Horne 5 Project. The respective distributions of these systems are shown in Figure 18-13.

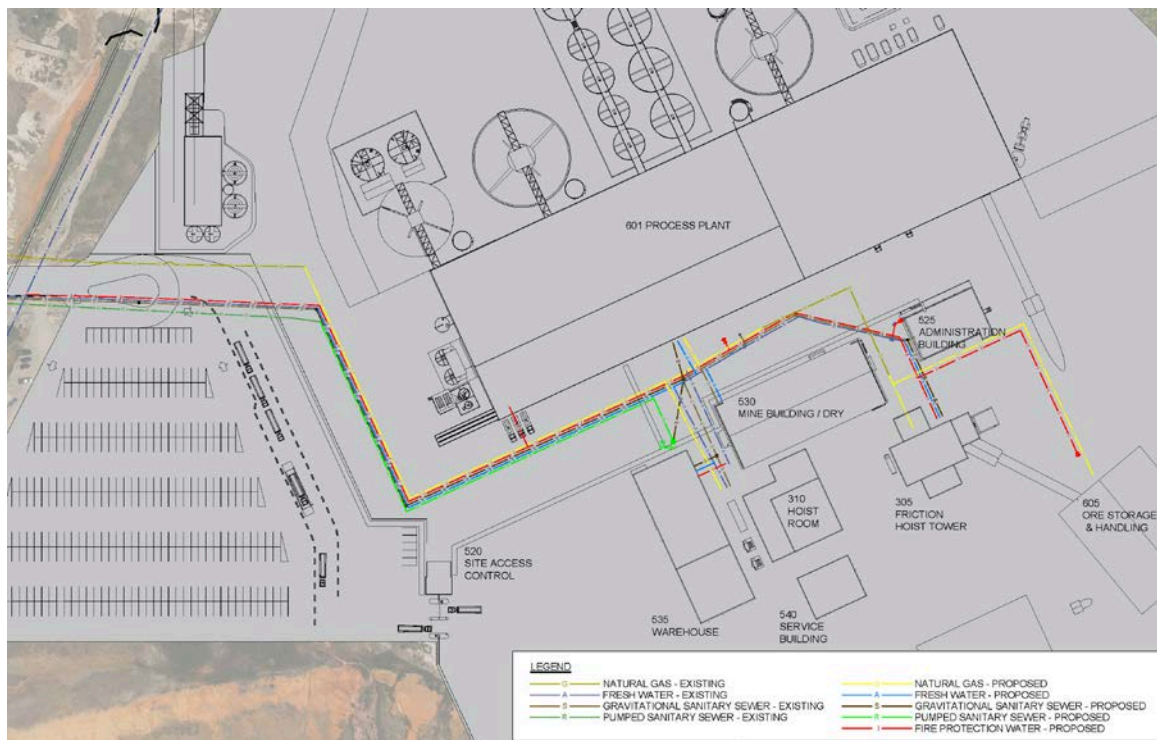

Figure 18-13: Underground utility piping

### 18.18.1 Fire Water and Distribution System

Site fire hydrants, as well as the surface buildings' sprinklers, will be supplied by an existing pipeline from Lac Dufault currently installed to the west of the Horne 5 Mining Complex. The main branch from the pipeline will feed booster pumps located in the process plant. The pumps will then feed one loop within the process plant and another underground line to service the buildings located to the south of Marcel-Baril Avenue.

The system will be equipped with an electrical booster pump with a capacity of 1,500 gpm under a pressure of approximately 100 psi, as well as a diesel back-up pump of equal capacity. Sprinkler systems will be installed in the warehouse, hoist room, head frame and the process plant. The sprinkler system will be located as to meet legal and insurance obligations in areas such as: belt conveyors, hydraulic and lube units, and cyclone clusters.

### 18.18.2 Potable Water

The potable water supply for the surface infrastructure will be connected to the city of Rouyn-Noranda’s potable water system. The existing network on the property will be modified to supply the new buildings.

The city’s potable water system has the capacity to provide the water requirements for the future mining complex, as is summarized in Table 18-4.

Table 18-4: Potable water requirements

Buildings	Average Requirements (litres/day)	Hourly peak Requirements (litres/day)
Site Access Control Building	300	27,255
Warehouse	1,000	54,510
Service Building	200	10,902
Administration Building	750	38,157
Mine Office/Dry Building	21,500	272,550
Process Plant	15,000	490,590
<b>Total (litres/day):</b>	<b>38,750</b>	<b>893,964</b>
<b>Total (US gpm):</b>	<b>7.11</b>	<b>164</b>

The future mining complex peak requirements of 164 gpm are well below the existing Quemont site system’s capacity of 888 gpm.

### 18.18.3 Sewage Treatment

The waste water sewage system for all surface infrastructure will be connected to the city of Rouyn-Noranda’s sewage treatment system with the exception of site surface drainage, which will be managed independently with a drainage system. The existing sewage pumping station will be replaced and a new pumping station will be installed to redirect the sewage to the city’s system. The existing network at the Horne 5 Mining Complex site will be modified to accommodate the new buildings.

The city’s system can supply the sewage treatment requirements for the future mining complex.

Table 18-5: Sewage treatment requirements

Buildings	Requirements (litres/day)
Site Access Control Building	530
Warehouse	1,300
Service Building	260
Administration Building	980
Mine Office/Dry Building	27,050
Process Plant	15,000
Hoist Room	200
Head Frame	200
<b>Total (litres/day):</b>	<b>45,520</b>
<b>Total (m<sup>3</sup>/day):</b>	<b>45.52</b>

#### 18.18.4 Natural Gas

The natural gas supplied to the future Horne 5 Mining Complex will originate from to the existing Gaz-Metro network. The existing buildings are currently supplied with natural gas but additional upgrades and modifications will be required to accommodate the Project requirements such as:

- Installation of an additional gas line along Marcel-Baril Avenue;
- Relocation of the gas line currently situated below the site of the future process plant;
- Installation of new underground natural gas lines to supply the existing and new buildings.

The estimated natural gas consumption is shown in Table 18-6.

Table 18-6: Natural gas requirements

Sectors	Requirements (m <sup>3</sup> /year)
Warehouse & Service Building	75,000
Mine Building and Dry	250,000
Process Plant	6,300,000
Headframe and Hoist Room	132,000
Underground Mine Air Intake	1,600,000
<b>Total (m<sup>3</sup>/year):</b>	<b>8,357,000</b>



### 18.19 Municipal Infrastructure

Marcel-Baril Avenue will be renovated to provide an exit point prior to the mine site entrance.

A new 150 mm diameter by 180 linear metre sewage water main will be constructed on Marcel-Baril Avenue to accommodate the site project requirements.

### 18.20 Site Infrastructure Relocation

There are currently existing buildings on the Horne 5 Project site which must be relocated or demolished to make way for new infrastructure. The current ECO-CENTER building will be demolished, other buildings will be re-purposed and thus the companies/services affected will be relocated.

#### 18.20.1 Lamothe, Div. de Sintra Inc.

Lamothe is currently using one of the historical Quemont administration buildings as their office building. Their aggregate crushing facilities and asphalt plant are currently located on the future process plant site. As part of the Horne 5 Project, Falco intends to relocate Lamothe's infrastructure (offices and crushing facilities) to a lot on Saguenay Boulevard, next to their quarry, where an existing building will be renovated for Lamothe's use. No agreement has been negotiated or entered into with Lamothe as of the effective date of the FS.

#### 18.20.2 Centre de Formation Quemont

The Centre Polymétier is currently using the historical Quemont building as an adult education and professional development school. As part of the Horne 5 Project, Falco will build an extension to the Centre Polymétier located on the site of La Source Secondary School, and the institutional activities will be permanently relocated to this new location. Falco has signed a Memorandum of Understanding with the Commission Scolaire de Rouyn-Noranda to own the existing building that bears the name Pavilion Quemont upon delivery of the relocation project. Construction began on the school relocation in September 2017.

As a result of the extension to La Source Secondary School, the existing soccer field must be relocated. As per the City of Rouyn-Noranda's request, it will be relocated to parc St-Luc, which is located in the Noranda-North neighborhood.

## 18.21 Tailings Management Facility Infrastructure

As per the tailings management strategy described in Chapter 20, the TMF will be located at the former Norbec Mine site, at approximately 11 km north-west from the Horne 5 Mining Complex site and consists of two separate cells: the PCT cell and PFT cell, and two water ponds: the Internal Pond and the Polishing Pond (see Figure 18-14).

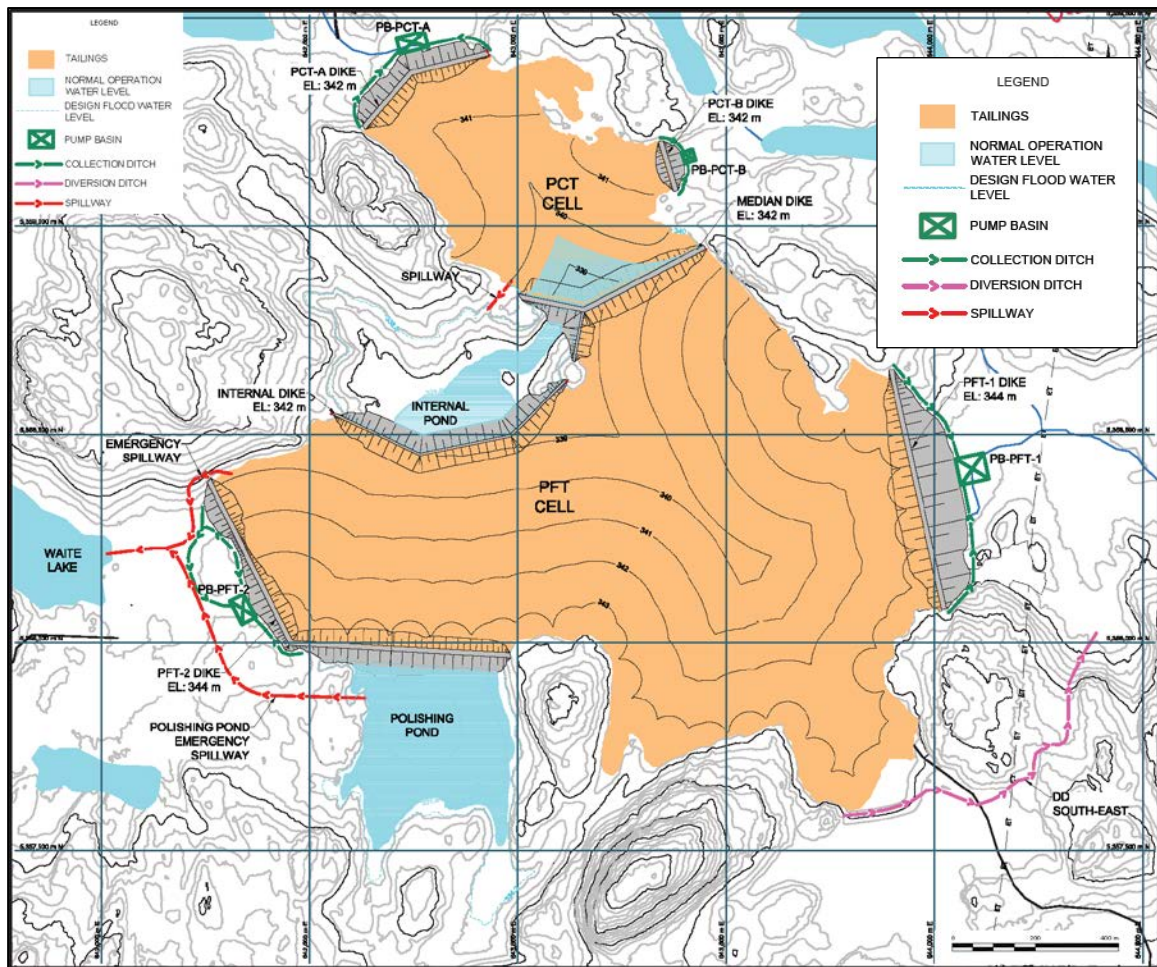

Figure 18-14: TMF infrastructure at the end of Stage 4 (2033)

Construction of the TMF is proposed to occur in five stages with each stage lasting approximately two to four operating years. The elevations for each stage are presented in Table 18-7.

Table 18-7: Dike elevations

Structure	Stage	1	2	3	4	5
		Q2 2023 – Q2 2025 (m)	(Q3 2025 – Q2 2027) (m)	(Q3 2027 – Q2 2029) (m)	(Q3 2029 - 2033) (m)	(2033-2035) (m)
PCT Cell: PCT-A and PCT-B Dikes		330.5	335.0	337.0	342.0	347.0
PFT-1		332.25	335.25	338.5	344.0	344.0
PFT-2		335.25	335.25	338.5	344.0	344.0
PFT-3		-	-	-	-	344.0
Median Dike		331	334	338.5	342.0	346.0
Internal Dike		331	334	338.5	342.0	342.0
New Polishing Pond Dike		-	-	-	-	344.0

The four external dikes, PFT-1, PFT-2, PCT-A and PCT-B will be required to confine the two cells and the polishing pond during the first four stages of operation. The plan is to build dikes PFT-1 and PFT-2 according to a very similar cross-section consisting of a granular fill with an upstream inclined low permeability element. The low permeability element will include a bituminous liner system consisting in the membrane itself laid on top of an appropriate transition layer and covered by a granular protection layer. A bituminous geomembrane liner is recommended considering its versatility, its long construction period and its requirement for lesser base-layer preparation. The total system thickness is in the order of 800 mm. The development of a quarry is planned to produce the granular fill and the various transition systems.

At stage 5, PFT-3 dike will be required as well as a new smaller polishing pond. The PFT-3 dike will be built according to a cross-section similar to the PFT-1 dike. The new polishing pond is expected to be entirely lined to avoid issues with dike connections.

The plan for the median dike is to build a rock fill structure with waste rock. A slurry trench or an equivalent low permeability system will be put in place to provide hydraulic separation between PFT and PCT cells. A final crest width of 12 m is planned for the median dike, but this width could vary depending on waste rock availability. A permanent pumping system will be installed at the PCT cell side starting with the first stage of development for pumping bleed water from PCT during operation and at closure.

The internal dike will separate the PFT cell from the internal pond. The plan is to build this structure as an entirely permeable feature using granular fill. A minimum of a 2.0 m wide transition layer system will be provided at the upstream side (towards PFT cell) of the internal dike. This transition layer system will consist in several granular layers and a geotextile in order to provide transition from the fine grained PFT to the granular fill and to prevent fines from being transferred to the pond. The system thickness and number of layers will be defined in the next stage of the design effort.

It is planned to put underdrains in place in the PFT cell if modelling results show the necessity of lowering the phreatic surface in the tailings mass and their potential efficiency. These underdrains could be extended to dikes PFT-1 and PFT-2 downstream side, if required, passing under the low permeability element.

The preliminary configuration of dikes at the PCT cell and the PFT cell consists in upstream slopes of 2H:1V and downstream slopes of 3H:1V. It is important to note that at the detailed design stage the geotechnical performance of all structures will be re-assessed taking into account field geotechnical investigation results and testing on foundation materials, construction materials and tailings.

Given the historical geotechnical data available in the vicinity of PFT-1, a preliminary stability analysis was performed for its proposed configuration. The results of the analysis show that a stability berm of 30 m long and approximately 8 m high will be required for the first TMF stage of operation. At the subsequent stages, it is assumed that the foundation will be allowed to consolidate and to dissipate excess pore water pressure. Therefore, the analyses for stages 2 to 5 were conducted in drained conditions. This hypothesis will have to be verified once the geotechnical investigation is completed. If the foundations are found to be incompetent, mitigation measures will be required. The mitigation measures could vary between foundation improvement (dynamic compaction, rock column, wick drains) and additional stability berms.

It is proposed to line the entire PCT cell as PCT tailings are expected to be highly reactive and to start acidification relatively rapidly at surface. The PFT cell may also require some improvement of the foundation conditions if exposed fractured bedrock surfaces or high permeability areas are encountered during geotechnical and geophysical investigations. For cost estimation purposes it was assumed that one third of the PFT cell footprint will have to be lined.

Prior to the construction of each external dike, a topsoil stripping and foundation preparation will be required. Surface bedrock might require grouting if its quality is inadequate. Provisions for grouting shallow curtain under dikes PFT-1 and PFT-2 has been made in the cost estimates.

---

## 18.22 Surface Water Management

### 18.22.1 Overall Water Management

As described more in detail in Chapter 20, the site water management will consist in managing water from the three main areas: the underground (during preproduction dewatering and operation), the Horne 5 Mining Complex and the Horne 5 TMF.

Water will be conveyed between these areas through pumping in order to allow:

- The development and the operation of the mine (dewatering and bleed water management);
- The ore recovery process (make-up water fulfillment);
- The safe management of the TMF;
- The proper drainage and surface water management of the mining complex and TMF areas (diversions of clean water, collection of contact and bleed water, safe conveyance of hydrologic design events).

### 18.22.2 Horne 5 Mining Complex

As per the overall water management strategy described in Chapter 20, surface water infrastructure will be built at the Horne 5 Mining Complex in order to adequately collect runoff water from this area. This infrastructure is designed to manage the 1:100-year precipitation event without overflow to the environment and aims to maximize the reuse of water to fulfill the Project's needs.

The following sections briefly describe the major surface water infrastructure that are planned at the Horne 5 Mining Complex plant site and give their preliminary sizing, as well as an estimate of the excavation and material quantities required for their construction.

Minor drainage infrastructure, such as rooftop drains, building internal sewers and superficial drains particularly to connect roof drains with the main storm-water system are not presented here and are considered included in the civil work associated with buildings.

Design and sizing of the major surface water infrastructure (ditches, culverts and pumping basins) are based on the design criteria listed in Chapter 20, Section 20.2.8, hydrological modeling and hydraulic calculations described in detail in the Horne 5 Feasibility Water Management Plan (Golder, 2017a).



### 18.22.2.1 Main Surface Water Management Infrastructure

Based on the future site topography, the ditches and pumping basins were placed as shown in Figure 18-15.

The process plant platforms (2 main levels) will be shaped and sloped in order to favor the proper drainage and limit the required excavation depths for ditches and basins. For practicality, two main drainage areas (watersheds) are defined on the process plant site:

- The first watershed corresponds to the south area of the process plant. It drains the higher level of the process plant site through ditches to pumping basin PR1 (drainage pond) located at the South-eastern corner of the site.
- The second watershed drains the north of the site (lower level), the ramp to access the lower platform and the parking lot at the entrance of the site. Water collected on those areas are conveyed through ditches and culverts to pumping basin PR2 (drainage pond) to the North of the site, on the lower platform.

The process plant site watersheds are limited to the process plant platform boundaries, as very few runoffs are expected to drain from the outside to the process plant site.

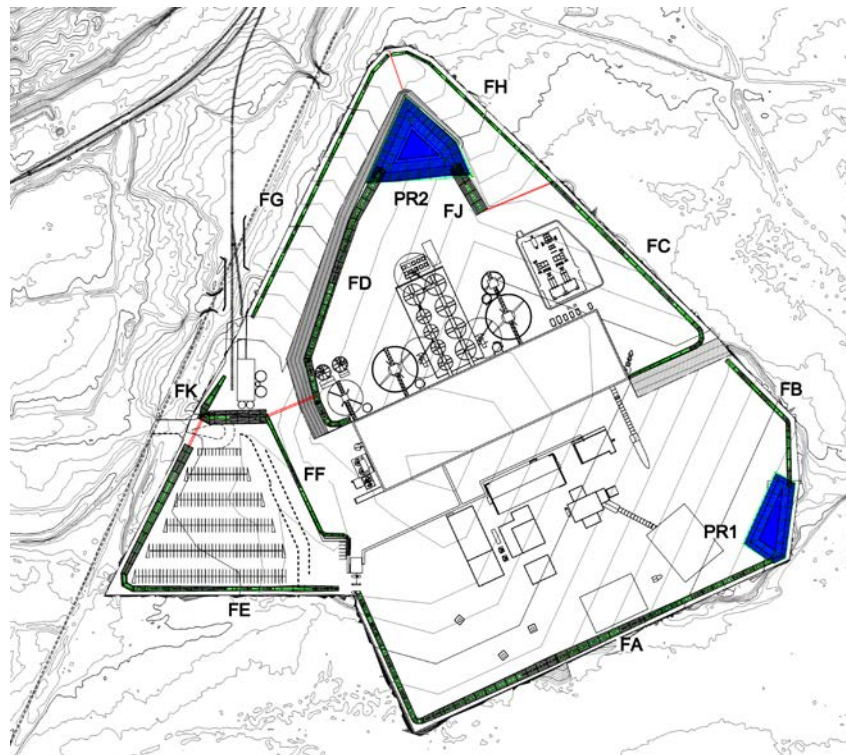

Figure 18-15: Ditches and pumping basins

### 18.22.3 Tailings Management Facility Site

As per the overall water management strategy described in Chapter 20, surface water infrastructure will be built at the TMF site to adequately collect or divert runoff water from this area. This water management infrastructure is designed according to the design criteria listed in Chapter 20 and aims at maximizing the reuse of water to fulfill the Project's needs, while limiting as much as feasible "non-impacted" runoff (from undisturbed areas) from entering the TMF site.

The following sections briefly describe the surface water infrastructure (major structures only) planned at the TMF site (clean runoff diversion channels, dike spillway channels, contact water collection ditches and pumping basins). The Horne 5 Feasibility Water Management Plan (Golder, 2017a) provides the preliminary sizing of these structures as well as an estimate of the excavation and material quantities required for their construction.

Internal drainage infrastructure, such as road/driveways drainage ditches and road crossing culverts, at the TMF site have not been considered at this stage.

#### 18.22.3.1 Water Management Infrastructure

As described in Chapter 20, there are three main types of water management structures throughout the TMF site:

- Surface water diversions (diverting non-contact water around the TMF). In total, three diversions will be required throughout the TMF life: the Vauze, the south-west and the south-east diversions;
- Seepage and contact water collection systems. Such systems will be composed of ditches and pumping basins located along the downstream toe of the site's perimeter dikes;
- Water ponds including their operational pumping systems and spillways.

An example, at a conceptual level, of the TMF surface water management infrastructure at Stage 4 is presented in Figure 18-14.

It is planned to use the Polishing Pond for PFT deposition at the end of the TMF operational life (Stage 5). This arrangement will require adapting the water management system including the construction of a new polishing pond downstream of dike PFT-2. The water management strategy at this point remains however very similar to the previous stages of the TMF development.

### 18.23 Water Treatment Infrastructure

Water treatment will be required at both the Horne 5 Mining Complex and the TMF site. Water treatment will be required throughout the duration of the Project for three main purposes:

1. Modify contact water quality to meet mining effluent discharge criteria (Provincial *D019 sur l'industrie minière* ("MDDEP 2012") and *Federal Metal Mine Effluent Regulations* – "MMER 2017"), including the non-toxic criterion, for water discharge in the environment.
2. Provide make-up water in sufficient quantity and quality to meet mining and processing requirements.

A prime component of the water treatment systems is the treatment of excess water during preproduction dewatering, during which the flooded former workings (mine pool) will be dewatered. Water treatment will continue through the production and closure phases to ensure that the anticipated discharge conditions are met.

Water treatment requirements will vary during the different phases of the Project:

- Preproduction dewatering: water treatment will consist of metals and sulphate removal. Ammonia Nitrogen ("TAN") treatment through final pH adjustment is anticipated to be required for a portion of the period. Polythionates removal may also be required for a portion of the period. The metals and sulphate treatment systems will produce a by-product sludge slurry, which will be backfilled in the existing workings (Quemont and Donalda);
- Production (without TMF): water treatment will consist of pH adjustment of a portion of the underground water for the operation requirements;
- Production (with TMF): water treatment will consist of pH adjustment for the operation water requirements and removal of metals, sulfate and cyanide prior to final discharge of excess water to the environment at the TMF site;
- Mine closure and reclamation: water treatment will consist of removal the metals, sulfate and cyanide prior to final discharge at the TMF site.

The information presented in this section is preliminary and will be refined following further characterization of the mine pool such as the completion of treatability tests for deep mine water from the historical Horne No. 4 shaft ("REMNOR"), and refinement and value engineering of the water treatment and sludge handling strategy during preproduction. The characterization of the deep mine water could have an impact on the by-product sludge volumes. The historical Horne and Quemont mines together represent 96% of the total mine pool to be treated, the remaining 4% is the Donalda mine pool.

Details on water treatment design and equipment are presented in Golder HDS Design Report (Golder, 2017b). Additional information on sludge (Golder, 2017c) and ammonia (Golder, 2017d) management are also available. Opportunities for optimization and identification of risks associated with some uncertainties are elaborated in Chapter 25.



### 18.23.1 Water Treatment Strategy

Mine water treatment will be required for the two sites involved in the Project:

- Horne 5 Mining Complex: this is the location of the underground mine and process plant.
- Norbec site: this is the location of the TMF and some excess water treatment facilities.

Water treatment will be required during the following phases of the Project:

- Preproduction: during which the historic mines will be dewatered to facilitate further delineation of the resource and to facilitate future production.
- Production (without TMF): during which tailings will be deposited underground.
- Production (with TMF): during which tailings that will not be used for backfill will be deposited at the TMF site located at the former Norbec Mine.
- Mine closure and reclamation stages.

The following Figure 18-16 is a simplified mine water treatment flow chart diagram presenting the main water sources, the expected flow (yearly average), and the expected discharge location for each effluent. The level and type of treatment required will vary depending on the inlet water quality and the expected discharge location to meet the regulatory requirements.

It is expected that during the preproduction dewatering, the historical mine treated water will be discharged via existing structures and discharge at the Dallaire watercourse. The TMF site currently has operating water treatment facilities including HDS and LDS facilities (together with the “WTP”) to ensure the proper water management of the existing site. It will maintain its current operation until the TMF is operational (preproduction and production without TMF). Stored water in Quemont (“Quemont Reservoir”) will be pumped and used in the process when the TMF site is available. During production, the process plant will draw some of the make-up water from underground and from the TMF site when the TMF is operational. Water stored in Quemont Reservoir will be pumped when the TMF site is available. A quantity of excess water will be discharged seasonally from the TMF site. During the reclamation stage, the sites will revert to treatment and discharge of excess water as long as required, similar to current operations. A summary of water treatment facilities is provided in Figure 18-16.

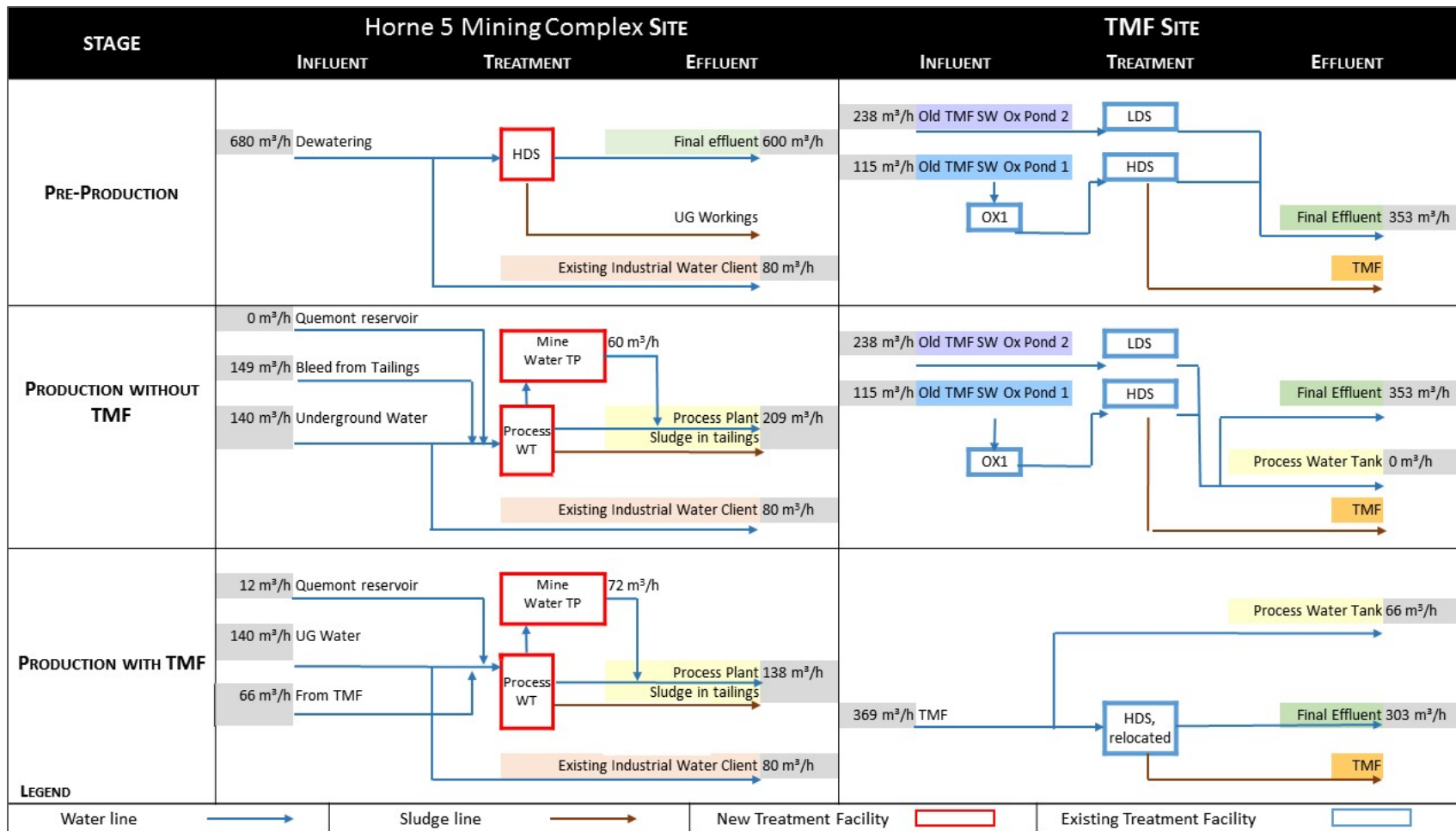

Figure 18-16: Simplified water treatment plans – preproduction and production

## 18.23.2 Water Treatment Facilities

The planned water treatment facilities may be summarized as follows:

### 18.23.2.1 Preproduction

#### Horne 5 Mining Complex

- New dewatering pumping infrastructure will be installed in the Quemont, Horne and Donalda mines;
- A temporary water treatment plant will be installed; it will be constructed so as to re-use the major equipment for production purposes after the end of the preproduction period;
- Facilities will continue to pump iron-rich untreated mine water to an existing industrial neighbor;
- Treated water will be discharged to Dallaire watercourse;
- Sludge pumping infrastructure, pipelines and distribution systems will be required to deposit the generated sludge in the available underground workings of Donalda and Quemont mines;
- Approximately 1.5 Mm<sup>3</sup> of water will be stored in the Quemont Reservoir until the TMF is operational;
- 0.176 Mm<sup>3</sup> will remain in Horne mine after the preproduction.

#### TMF Site

- Existing WTP will continue to manage the excess site contact water at Oxidation Basins OX-1 and OX-2 during the preproduction period.

### 18.23.2.2 Production without TMF

#### Horne 5 Mining Complex

- Following the preproduction phase, the pre-production water treatment plant will be shut down, and the major equipment will be relocated/re-tasked and integrated at the process plant;
- Solids separation devices will be implemented in underground sumps to remove slimes, grit and other suspended solids in mine water prior to pumping the water to the surface;

- New lime treatment feed point will be installed in the process circuit to adjust the pH of some of the excess underground water during operations in order to meet the operation needs. The mine water will be neutralized in the presence of tailings solids to encourage densification of sludge. This will serve as make-up water until the TMF and the reclaim water pipeline are operational. Therefore, there will be no discharge of water at Horne 5 Mining Complex; mine water is reclaimed in process plant;
- Sludge generated during production by the addition of lime will remain in the process water and be handled at the process plant.

#### TMF site

- Existing WTP will continue to manage the excess site contact water at Oxidation Basins OX-1 and OX-2 until the TMF infrastructure is operational.

### 18.23.2.3 Production with TMF

#### Horne 5 Mining Complex

- Solids separation devices will continue to operate in underground sumps to remove slimes, grit and other suspended solids in mine water prior to pumping the water to the surface;
- The lime treatment feed points installed in the process circuit will continue to operate but with a nominal capacity of 138 m<sup>3</sup>/h to adjust the pH of the excess underground water during operations in order to meet the operation needs. The mine water will be neutralized in the presence of tailings solids to encourage densification of sludge;
- 1.5 Mm<sup>3</sup> of mine water stored in the Quemont reservoir will be neutralized if necessary and metered slowly to the tailings streams and transported to the TMF over the life of mine.

#### TMF site

- Existing lime treatment facilities at the TMF site will be relocated since the current locations of the facilities will be eventually submerged by tailings. Hydrogen peroxide treatment will be initiated, for cyanide polishing from the lime treatment system. Water will be treated as required to maintain adequate pond levels, excess water will be discharged if needed;
- New polishing ponds and sludge pond(s) will be constructed since the existing ponds will be submerged by tailings;
- Reclaim water will return to the Process plant.

### 18.23.3 Mine Closure Water Treatment

The water treatment will be modified during and following progressive closure of the two sites.

At the Horne 5 Mining Complex site, it is anticipated that the mine dewatering systems will be shut off at the end of the mine life, and the mine will slowly refill. Surface water will be managed in a manner that is consistent with current operations. After the mine has been filled, pumping will be required to maintain a hydraulic trap to contain mine contact waters. No additional allowance is anticipated beyond what is currently practiced by the existing industry.

At the TMF site, water treatment is anticipated for a number of years following the end of mine life during progressive closure activities. This treatment is initially expected to be analogous to the current treatment demands, but this treatment will gradually decrease as closure is completed. Where appropriate, water treatment sludge from the TMF operations may be stockpiled as a component of covers and caps for mine wastes.

A schematic of the closure water treatment plans is provided in Figure 18-17.

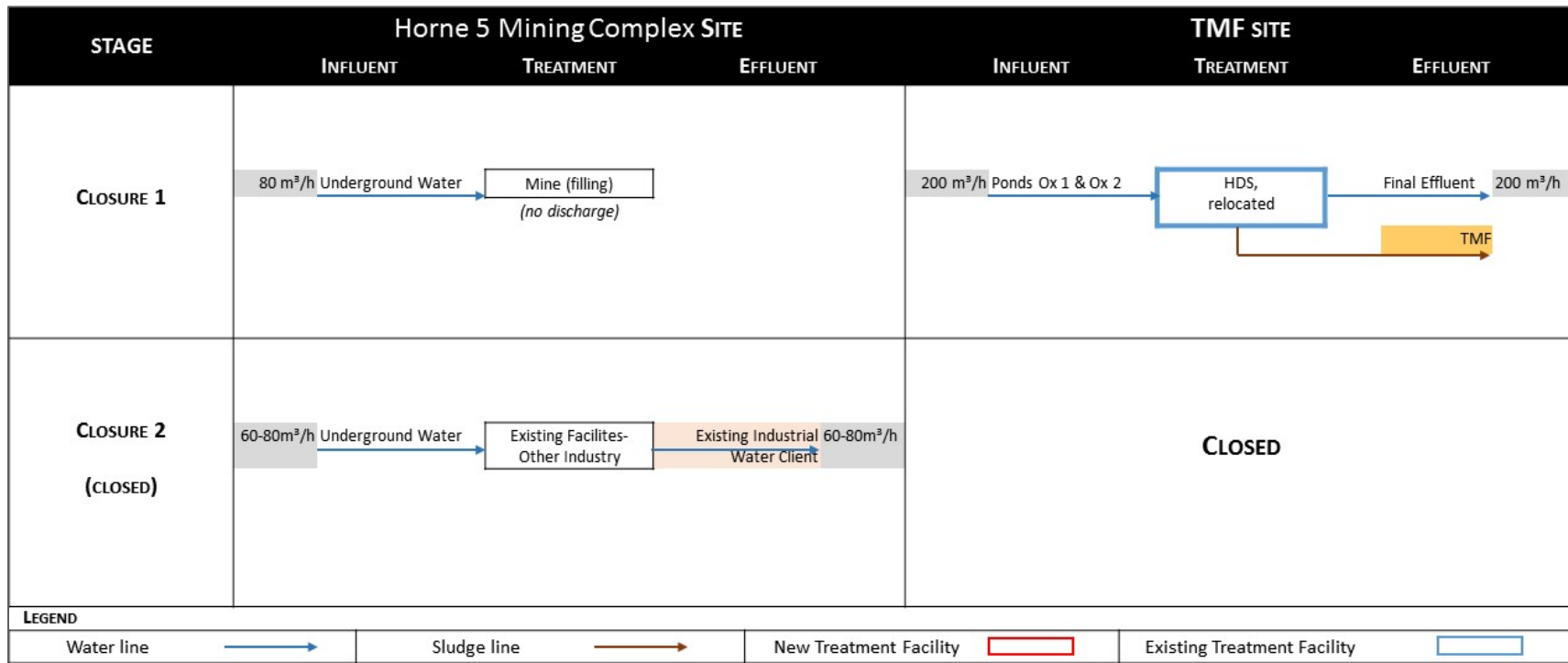

Figure 18-17: Simplified water treatment plans for progressive closure

#### 18.23.4 Available Water Quality and Flow Data

The anticipated flow and main inlet water quality for each water source within each phase are presented in Table 18-9 to Table 18-12. These tables provide a preliminary guide regarding the implication of water treatment during the different periods of the Project.

#### Preproduction

For the purpose of this analysis, the mine pool was defined by four types of water quality, represented by the upper and lower portion of Quemont and the upper and lower portion of historical Horne mine. The number of samples from the historical Horne mine is limited, so this analysis will be revised once further characterization is completed. Chapter 25 outlines recommended additional work and risks associated with the current characterization of the deep mine pool. Table 18-8 identifies the water volume of the Horne, Quemont and Donalda mine pools according to four assumed types of water quality as characterized in Table 18-9. The Chadbourne and Joliette mine pools will be hydraulically isolated, therefore the proposed dewatering plan and sludge generation estimates do not consider dewatering of these areas. For improved treatment process consistency, the process will aim at blending different water quality in order to minimize water quality fluctuation at the treatment feed.

The detailed dewatering schedule is presented in Chapter 16 (Section 16.4.6).

Table 18-8: Mine pool water quality and volume estimates

Depth (m)	Water Quality			Water Volume – m <sup>3</sup>		
	Horne	Quemont	Donalda	Horne	Quemont	Donalda
0 – 100	Water quality #3	Water quality #1	Water quality #1	2,143,000	261,000	168,700
100 – 300	Water quality #3	Water quality #2	Water quality #2	2,405,000	951,000	214,700
300 – Bottom <sup>(1)</sup>	Water quality #4	Water quality #2	n/a	2,151,000	751,000	0
<b>Total</b>				<b>6,699,000</b>	<b>1,963,000</b>	<b>383,400</b>

<sup>(1)</sup> Bottom depth is defined as the limit of dewatering: Quemont and Donalda are completely dewatered and the Horne pool is initially dewatered/treated down to 687 m, then pumped down to 1,250 m for storage in the Quemont mine voids. For the Horne pool during preproduction, the water volume between 687 m and 1,250 m, estimated to be 1,548,000 m<sup>3</sup>, is not shown in the Table 18-8 as it is not treated and therefore does not contribute to sludge generation.

Table 18-9: Four water qualities representing the mine pools\*

Water Quality	pH	Sulphate (mg/L)	Iron (mg/L)	Magnesium (mg/L)	Copper (mg/L)	Zinc (mg/L)	Nickel (mg/L)	Ammonia (mg/L)	Polythionates (mg/L)	SGR <sup>(1)</sup> (g dry/L)
Effluent Quality Directive 019	6.5 - 9.5	(2)	3	-	0.3	0.5	0.5	(2)	(3)	-
<b>Average Water Qualities</b>										
Water quality #1	< 6	1,610	220	55	0.0013	0.74	0.41	0.9	63	0.5
Water quality #2	< 4	11,777	3,050	1,126	0.02	5.15	0.025	1.8	473	21
Water quality #3	< 4	6,400	2,420	215	0.61	10.9	0.2	0.13	216 <sup>(4)</sup>	7
Water quality #4	< 4	44,700	18,800	1,463	0.031	201	0.05	17	763 <sup>(4)</sup>	117
<b>Water Quality Ranges</b>										
Water quality #1	-	1,400 - 1,820	210 - 225	44 - 65	0.0013 - 0.0014	0.48 - 1.0	0.18 - 0.65	0.9 (one sample)	63 (one sample)	n/a
Water quality #2	-	8,170 - 16,000	1,985 - 3,500	770 - 1,475	0.002 - 0.12	2.95 - 6.7	0.01 - 0.08	0.19 – 3.5	269 - 698	n/a
Water quality #3	-	5,990 - 7,196	1,135 - 3,235	132 - 308	0.04 - 1.9	4.04 - 15.5	0.04 - 0.34	< 0.01 – 0.25	<3 – 567 <sup>(4)</sup>	n/a
Water quality #4	-	31,735 - 49,821	17,298 - 19,603	685 - 2,776	0.021 - 0.085	121 - 215	0.04 - 0.06	7.6 - 30	<3 – 1260 <sup>(4)</sup>	n/a

n/a: not applicable

\* Rounded values are presented. Concentrations are based on weighted average values from Quemont and Horne mine pool characterization. 30 samples were available for Quemont and 7 samples were available for Horne. Since no sample data was available for Donalda, the Quemont water quality (upper and deep) was assumed to be most representative (Donalda only represents 4% of the mine pool).

- (1) To evaluate the solids generation rate (“SGR”), a chemical model was used for water quality #3-4 and laboratory testing work for water quality #1-2. Additional laboratory testing is recommended to refine the SGR estimates for water quality #3-4. The SGR is based on the contained metals and sulphate, but the data are limited. If the measured sulphate is artificially raised to balance the metals in the water, then the SGR of water quality #4 can be expected to be higher.
- (2) D019 does not provide specific limits for sulphate or ammonia. The water should comply with the acute toxicity limit for trout (*Oncorhynchus*) and daphnia (*Daphnia magna*).
- (3) The thiosalts concentration should not cause a drop in pH lower than 6.0 or over 9.5 in the aquatic receptor, and should not cause acute toxicity.
- (4) The polythionates concentration varies depending of the ferrous ion interference. Some of the laboratory protocols for polythionates concentration were done without pre-treatment for the ferrous interference. Thus, values presented in the table are expected to be overestimated for these samples.



The mine water is dominated by the sulfate anion, mainly balanced by iron and magnesium cations. The pH of the water in some samples is above 5 S.U., however, the pH of these samples drops dramatically upon exposure to air, through oxidation and hydrolysis of iron. The weighted average of the lime consumption was used for cost estimation purposes.

The volume of the underground workings, and thus the treatment volumes, were estimated from digitizations of workings. The actual volume may vary. Furthermore, the water quality prediction for the four mine water types is an approximation that is subject to further characterization.

It is significant to note that five of the twelve samples collected in historical Horne No. 4 shaft, in March 2017 and August 2017, were collected at a deeper level corresponding to 400 m, 500 m and 600 m. The volume associated with the deep Horne mine is approximately 2.1 Mm<sup>3</sup> and the samples are approximately five times more impacted, in terms of metals and sulfate concentrations, than the upper mine pool samples. Subsequently, the water from the deep Horne mine will not be treated but rather stocked in the historical Quemont mine to be used in ore process at the early stage of the process plant start-up.

### Production without TMF

The following Table 18-10 is based on the available water quality sample for the upper mine and the deep mine, and from the historical water quality at TMF site.

Table 18-10: Water quality design basis for treatment – production without TMF

Parameters	Units	Underground Water <sup>(1)</sup>	Bleed Water <sup>(2)</sup>	TMF Site Surface Water Basin OX-1 <sup>(3, 4)</sup>	TMF Site Surface Water Basin OX-2 <sup>(3, 5)</sup>
<b>Hydraulic Data</b>					
Average flow rate	m <sup>3</sup> /h	140	149	115	238
Duration of treatment	year	2	2	2	2
<b>Water Quality Data</b>					
pH	-	< 4	7.8	2.8	- <sup>(5)</sup>
Dissolved Iron	mg/L	Between 17,298 – 19,603	0.2	115	- <sup>(5)</sup>
Dissolved Sulphate	mg/L	Between 31,735 - 49,821	1805	Between 0 – 1,100	- <sup>(5)</sup>
Dissolved Copper	mg/L	Between 0.021 - 0.085	9.7	4	- <sup>(5)</sup>
Dissolved Zinc	mg/L	Between 121 - 215	0.05	10	- <sup>(5)</sup>
Polythionates	mg/L	Between < 3 – 1260	0 <sup>(6)</sup>	- <sup>(7)</sup>	- <sup>(5)</sup>
Total Cyanide	mg/L	Between < 0.001 – 0.096	5	- <sup>(7)</sup>	- <sup>(5)</sup>
Total Ammonia	mg/L	Between 7.6 - 30	0	- <sup>(7)</sup>	- <sup>(5)</sup>

- (1) Underground water concentrations based on worst case Horne water samples, corresponding to Water Quality (“WQ”) #4, in order to mitigate the risk of variability in water quality. Concentrations subject to change with further characterization of mine water continues.
- (2) Concentrations based on preliminary modelling for dissolved water constituents, subject to change.
- (3) Approximate average values estimated based on provided documentation of Norbec water treatment since 2001, subject to change.
- (4) Water in OX-1 will be treated with existing HDS plant at the current flow (no modifications); estimated lime dose of 0.15 g/L as Ca(OH)<sub>2</sub>.
- (5) Water in OX-2 will be treated with existing LDS plant at the actual flow (no modifications); estimated lime dose of 5 mg/L as Ca(OH)<sub>2</sub>.
- (6) The polythionates are considered completely oxidized to sulphate, subject to change.
- (7) Similar to existing conditions, no specific treatment currently at the Norbec site for cyanide and cyanide residuals. Site is under progressive closure.

During the production without TMF, the mine water is expected to be a mixture of acidic water, similar to the preproduction mine water, and neutral water draining from the tailings. The neutral water will be blended with the underground water prior to treatment at the process plant. Based on the operation needs, an average rate of 60 m<sup>3</sup>/h is planned to be treated during production without TMF, the balance will be recycled without treatment.

## Production with TMF

The following Table 18-10 is based on the available water quality samples for the Horne deep mine, and from the historical water quality at Norbec site. The Quemont reservoir (filled with Horne deep water during the preproduction period) will be pumped to the process plant at a rate varying with the operation requirements. For the average flow rate, the total volume of the Quemont reservoir over the period was considered.

Table 18-11: Water quality design basis for treatment – production with TMF

Parameters	Units	Underground Water <sup>(1)</sup>	TMF Site Surface <sup>(2)</sup>
<b>Hydraulic Data</b>			
Average flow rate	m <sup>3</sup> /h	138	237
Duration of treatment	Year	15	15
<b>Water Quality Data</b>			
pH	-	< 4	2.8
Dissolved Iron	mg/L	Between 17,298 – 19,603	115
Dissolved Sulphate	mg/L	Between 31,735 - 49,821	Between 0 – 1,100
Dissolved Copper	mg/L	Between 0.021 - 0.085	4
Dissolved Zinc	mg/L	Between 121 - 215	10
Polythionates	mg/L	Between < 3 – 1260	- <sup>(3)</sup>
Total Cyanide	mg/L	Between < 0.001 – 0.096	- <sup>(4)</sup>
Total Ammonia	mg/L	Between 7.6 - 30	- <sup>(5)</sup>

<sup>(1)</sup> Underground water concentrations are based on worst case Horne water samples, corresponding to WQ #4, in order to mitigate the risk of variability in water quality. Concentrations are subject to change as characterization of mine water continues.

<sup>(2)</sup> Approximate average value estimated based on provided documentation of Norbec water treatment since 2001, subject to change.

<sup>(3)</sup> The polythionates are considered completely oxidized to sulphate, subject to treatability tests.

<sup>(4)</sup> Similar to existing conditions, no specific treatment currently at the Norbec site for cyanide and cyanide residuals. Site is under progressive closure.

<sup>(5)</sup> To be confirmed (awaiting process water analysis).

## Closure Stage

For the purpose of cost estimation, it is expected that the water quality at the TMF site during the closure stage will be of similar or better water quality than the current Norbec site. Additional water quality modelling is recommended to refine the predictions for closure water treatment needs.

Table 18-12: Water quality design basis for treatment – closure stage

Parameters	Units	TMF Site Surface Water <sup>(1)</sup>
<b>Hydraulic Data</b>		
Average flow rate	m <sup>3</sup> /h	200
Duration of treatment	year	5 years <sup>(3)</sup>
<b>Water Quality</b>		
pH	-	2.8
Dissolved Iron	mg/L	115
Dissolved Sulphate	mg/L	Between 0 – 1,100
Dissolved Copper	mg/L	4
Dissolved Zinc	mg/L	10
Polythionates	mg/L	- <sup>(2)</sup>
Total Cyanide	mg/L	- <sup>(2)</sup>
Total Ammonia	mg/L	- <sup>(2)</sup>

<sup>(1)</sup> Approximate average value estimated based on provided documentation of Norbec water treatment since 2001, subject to refinement to include influence of the TMF. Tapering water treatment over 5 years (flow and quality).

<sup>(2)</sup> Similar to existing conditions, no specific treatment currently at the Norbec site for cyanide, cyanide residuals and polythionates. Site is under progressive closure.

<sup>(3)</sup> 5-year closure period is an assumption provided by Falco and is subject to review with the development of a closure plan

### 18.23.5 Water Treatment Technology

The selected water treatment approach relies on the principle that the addition of an alkali reagent and air to facilitate oxidation of ferrous ion and polythionates, and the precipitation of gypsum and metal hydroxide solids (high density sludge). Treated water may be neutralized following treatment to meet the discharge target of pH 6-9, and to remove un-ionized ammonia sufficient to meet toxicity requirements.

### Preproduction – Dewatering

For the dewatering period, due to the high strength water, water treatment alternatives were compared and analyzed for process selection in order to result in an efficient cost, including the cost of sludge management. A three-step HDS process using lime as a neutralization agent was selected as the preferred option for the feasibility design. The proposed water treatment isometric diagram is presented in Figure 18-18 below, and the simplified HDS process flow diagram is shown in Figure 18-19. The detailed design criteria and equipment selection for the HDS systems is described in the Golder HDS Design Report (Golder, 2017b).

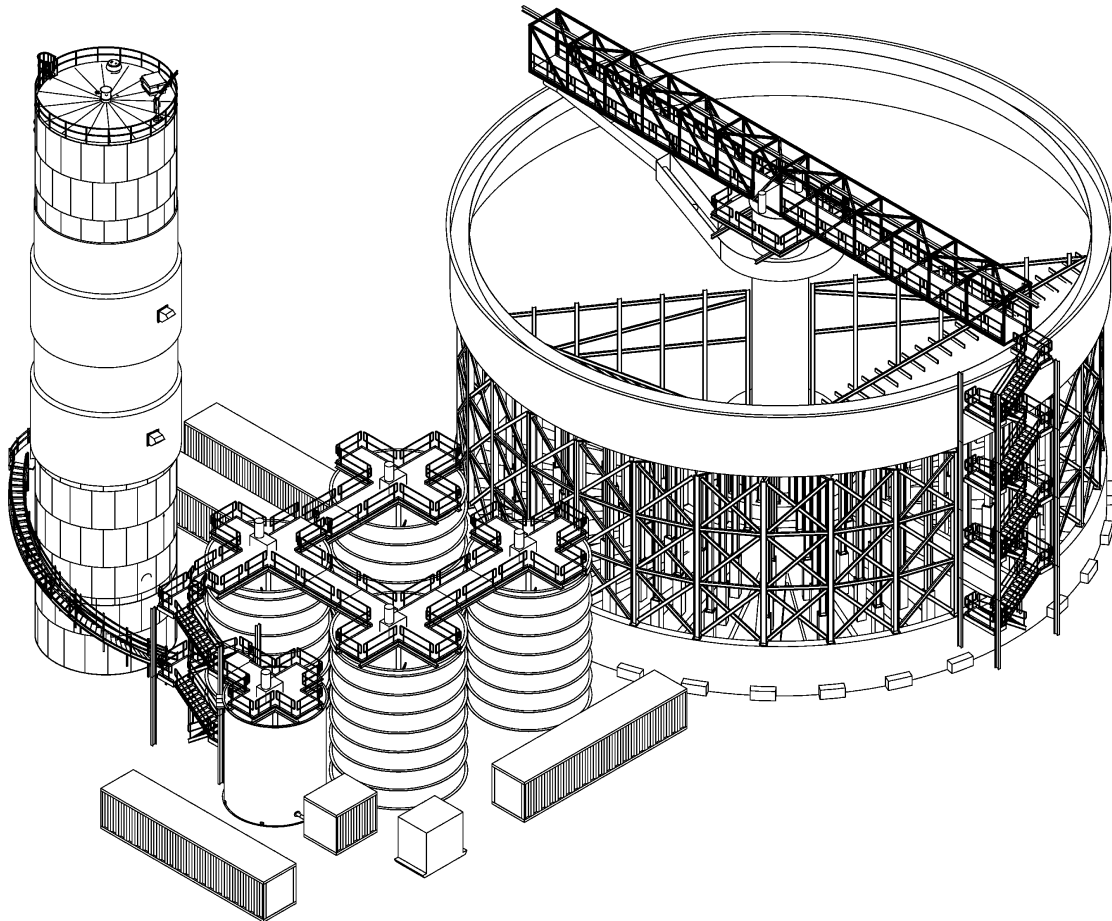

Figure 18-18: Water treatment plant isometric diagram

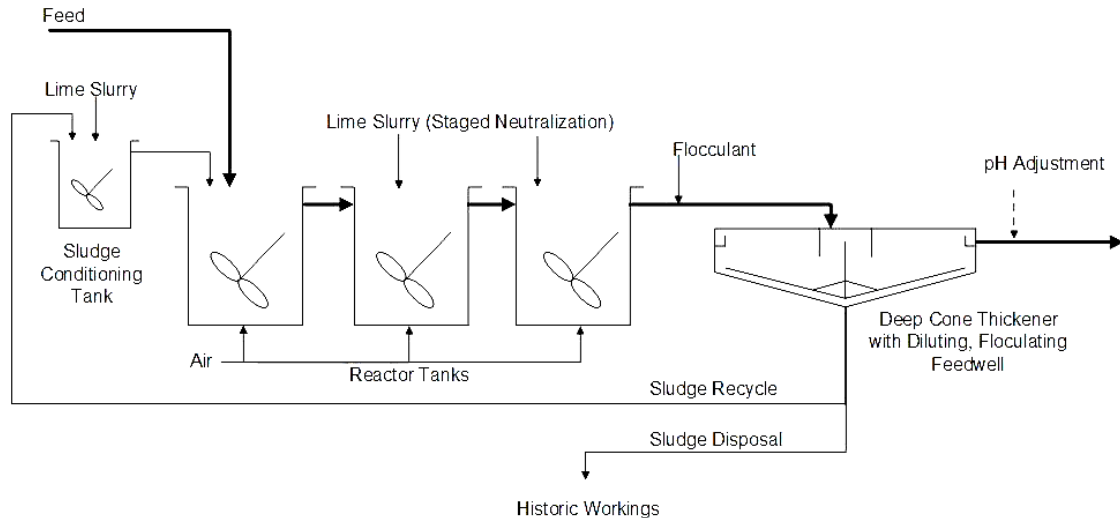

Figure 18-19: Simplified HDS process flow diagram

## Production

During production, the underground water will be treated as follows:

- Facilities will continue to pump iron-rich mine water to industrial neighbour for process uses;
- During the production, underground mine water will be collected in sumps and treated only for removal of slimes, grit and other suspended solids. The clarified water will be pumped to the surface via a pipe in the shaft. At the surface, the water that cannot be recycled without treatment is treated in the PFT tailings slurry tank (production with TMF) or the pre-leach thickener (production without TMF) with added lime if necessary. The tailings slurry is expected to be approximately 25% to 60% solids thereby promoting the densification of the water treatment sludge. The sludge will be co-disposed with tailings.
- TMF site during preproduction and production without TMF, excess water at the TMF site will be treated in existing systems (LDS and HDS). With the development of the TMF, these systems will be relocated. Peroxide and sulfuric acid will be dosed into the effluent to handle the residual cyanide and to adjust the pH.

The treatment sequence will be reviewed and optimized based on additional water treatment tests and on the final adaptation to the water management strategy.

## Reclamation and Closure

The closure of the Horne 5 Mining Complex will consist of allowing groundwater to refill the mine and reverting to initial conditions.

The closure of the TMF site will consist of reclamation of the TMF collection of site run-off, and treatment of excess water to meet the anticipated discharge requirements. The closure water treatment will use the existing relocated WTP, if necessary.

### 18.23.6 Sludge Handling Strategy

A large quantity of sludge will be produced by the treatment of acidic water during the preproduction dewatering. Sludge is projected to be deposited in existing underground workings. During production, the sludge will be mixed with the tailings, both during underground deposition and with the TMF. For improved treatment process consistency, the water from different zones with different water quality will be blended to minimize sludge loading fluctuations.

The calculated solid generation corresponds to the sum of metal hydroxide and gypsum precipitates, and the suspended solids present in the water. The calculated number, referred to as SGR is expressed as a kilogram of dry solids per cubic metre of feed water and is based on chemical modelling and laboratory testing. The following Table 18-13 presents the estimates for the expected sludge volume.

Table 18-13: Expected sludge volume

Phases	Sludge Dry Mass	Expected Sludge Solids (w/w) (%)	Sludge Volume (m <sup>3</sup> )	Deposition Location
Dewatering – Stage 1 1.78 Mm <sup>3</sup> total	Est. 0.5 – 21 kg dry solid per m <sup>3</sup> feed water <sup>(3)</sup>	35	65,500 <sup>(3)</sup>	In Donalda workings
Dewatering – Stage 2 4.59 Mm <sup>3</sup> total	Est. between 7 – 21 kg dry solid per m <sup>3</sup> feed water <sup>(3)</sup>	35	91,500 <sup>(3)</sup>	In Donalda workings
Dewatering – Stage 3A 2.7 Mm <sup>3</sup> total to treatment	Est. 7 – 117 kg dry solid per m <sup>3</sup> feed water <sup>(3)</sup>	35	583,600 <sup>(3)</sup>	In Donalda and Quemont workings
Dewatering – Stage 3B 1.55 Mm <sup>3</sup> total not treated	n/a	n/a	n/a	The pumped water from Horne will be transferred to Quemont reservoir without treatment

Phases	Sludge Dry Mass	Expected Sludge Solids (w/w) (%)	Sludge Volume (m <sup>3</sup> )	Deposition Location
Production without TMF 209 m <sup>3</sup> /hr average flow mixed acid water	Up to 33 kg dry solid per m <sup>3</sup> feed water	20 <sup>(1)</sup>	Up to 575,000 <sup>(2)</sup>	Sludge will be co-disposed with tailings
Production with TMF 72 m <sup>3</sup> /hr acid water including transfer from Quemont reservoir	Up to 62 kg dry solid per m <sup>3</sup> feed water	20 <sup>(1)</sup>	Up to 2,400,000	Sludge will be co-disposed with tailings

n/a: not applicable

- (1) Acid water mixed with tailings at 62% solids produces a medium density solid through a particle growth and occupying interstitial spaces.
- (2) Considering the worst underground water quality mixed with good quality tailings bleed or contact water.
- (3) SGR and sludge volume estimates are subject to change based on: further characterization of deep mine water, laboratory testwork for deep mine water, and confirmation of density. In the case of deep mine waters, when sulfate is adjusted to address the ionic balance, the SGR for stage 3 increases up to 126 g/L. Equipment sizing for capital cost estimates has considered the higher values as a contingency.

The quantity of sludge to be generated will be refined following the completion of the upcoming treatability tests and additional water sampling and analyses.

The sludge produced during the preproduction period will be pumped and backfilled as described in Section 16.9.

## 18.24 Tailings Pipelines

During production with TMF, the PFT and the PCT are transported separately from the process plant to the TMF.

### 18.24.1 Tailings Pipeline Route

Based on the current routing of the pipelines, as seen in Figure 18-1, the transport segment of each pipeline between the process plant and the TMF is approximately 17.4 km long. The distribution pipelines that will be used to deposit tailings around the TMF are 4.8 km for the PFT and 2.7 km for the PCT. The maximum length of each pipeline for pumping is 20.8 km for the PFT and 20.1 km for the PCT.

The pipelines will be installed mostly above ground, with underground segments achieved through open and cut construction or horizontal directional drilling (“HDD”) for river, wetland and road crossings. The total length of underground installation is evaluated at 1.8 km. No geotechnical or hydrological data were available at the time of this Report. The construction method will be assessed when geotechnical and hydrological data become available.



### 18.24.2 Tailings Pipeline Design

The PFT pipeline includes a 17.4 km segment of 10-inch pipe between the process plant and the TMF as well as a 4.8 km segment of 12-inch HDPE pipe around the TMF. The transport section of the pipeline will be lined with HDPE as a mitigation measure against potential corrosion and will be thermally insulated.

The PCT pipeline includes a 17.4 km segment of 12-inch carbon steel pipe between the process plant and the TMF as well as a 2.7 km segment of 12-inch HDPE pipe around the TMF. The transport section of the pipeline will be lined with HDPE as a mitigation measure against potential corrosion and will be thermally insulated.

Manual knife gate isolation valves will be located every 100 m on the distribution pipelines. Manual segmentation valves will be located every 500 m on the distribution pipeline and will allow movement of the pipelines during TMF raises without shutting down the system.

### 18.24.3 Tailings Pipeline Operation

There are two pipeline operating scenarios: 1) paste backfill plant shutdown; and 2) paste backfill plant operating. When the paste backfill plant is shut down, the PFT and PCT pipelines operate full of slurry. The pipelines require dilution to manage reduced throughputs and pipelines are shut down only after flushing.

When the paste backfill plant is shut down, PFT is transported at 62 wt% solids, and PCT is transported at 47 wt% solids.

When the paste backfill plant is operating, a reduced throughput of PFT is transported and diluted to maintain flow above the minimum pipeline operating velocity. The PCT pipeline will stop operating as all tailings are used for paste backfill. If only one paste backfill production line is operating, further dilution of the tailings will be required. During winter, the PCT pipeline needs to maintain the pumping of water. If water is not recirculated during these normal operating conditions (backfill plant operation accounts for approximately 60% of operating time), the pipeline will require draining. Insulation does not prevent freezing; it only slows down the process.

There will be two operating conditions for the PFT pipeline for each of the operating modes regarding paste backfill plant operation. The operating and control philosophy will be programmed into the control system for safe system operation. The control system will not allow the PFT pipeline to operate at the lower concentration minimum velocity when pumping 62 wt% solids tailings. Operating at the lower minimum velocity with the higher solids concentration could result in a plugged PFT pipeline. The operating conditions will be determined during commissioning of the system.

Flow of PFT and PCT in the pipeline will be continuous. If the flow is about to drop under the minimum velocity, the incoming tailings will be diluted before reaching the pumps to ensure adequate volumetric flow.

For deposition into the TMF, three to five discharge points shall be operated at a time. Tailings shall be deposited starting at the first spigot and progressively moving towards the last spigot on the line. In the case of the PFT, there are two pipeline branches for tailings distribution. Only one branch should be operated at a time, starting with the first spigot on one branch and progressively advancing towards the last. When the sequence is complete, deposition should restart from the first point on either branch. The number of spigots will evolve with the TMF to maintain distribution of tailings around the perimeter.

## 18.25 Reclaim Water Pipeline

The reclaim water pipeline will follow the same route as the tailings pipelines but pipeline flow will be in the opposite direction. The reclaim water pipeline will be approximately 19.4 km, which can be seen in Figure 18-1.

The reclaim water pipeline will be installed above ground directly on the ground with underground crossings. The pipeline will be assembled from 19,400 m of 20-inch HDPE. The pipeline will be thermally insulated.

The reclaim water pipeline is designed for a maximum flow rate of 750 m<sup>3</sup>/h.

The pumping system at the TMF will be a barge mounted vertical turbine pumps, with at least one spare pump.

Flow in the reclaim water pipeline will be continuous. During winter, the pipeline will maintain flow to prevent freezing.

## 18.26 Fresh Water Infrastructure

### 18.26.1 Fresh Water Pump House and Pipeline

A sea container consisting of two horizontal centrifugal pumps (one running and one spare) and an electrical room will serve as the fresh water pump house. It will be installed on Rouyn Lake to provide fresh water to the process plant. The fresh water pipeline will be approximately 7.1 km long and the route is shown in Figure 18-20 below.

The fresh water pipeline will be installed above ground with underground crossings as required. The pipeline will be assembled from 14-inch HDPE DR 11 pipe.

The fresh water pipeline is designed for a maximum flow rate of 375 m<sup>3</sup>/h. Flow in the pipeline will be continuous. During winter, the pipeline will maintain flow to prevent freezing.

A portion of the treated water effluent pipeline used during the preproduction dewatering of the old mines will be re-used for the fresh water pipeline as they share a common route between the Horne 5 Mining Complex and the Dallaire watercourse.



Figure 18-20: Fresh water pipeline

## 19. MARKET STUDIES AND CONTRACTS

The primary production from the mine will include copper/gold/silver (Cu/Au/Ag) and zinc/silver/gold (Zn/Ag/Au) flotation concentrates, both to be marketed to third-party smelting companies. In addition, the site will be producing gold/silver (Au/Ag) doré, which will be sent to a refinery for refining into fine gold and silver bars. There are currently no sales contracts for this Project. Glencore Canada has rights of first refusal with respect to purchase or toll process all or any portion of the concentrates and other mineral products from the Horne 5 Project.

### 19.1 Base Metal Concentrate Sales

The long-term outlook for copper and zinc is favourable, with growing demand for both metals matched by only limited projected mine supply growth, translating into favourable market conditions for the copper and zinc concentrates that will be produced at Horne 5.

Metal prices used in derivation of the NSRs were as per Table 19-1.

Table 19-1: Metal prices used in derivation of the NSRs

Metal / Currency	Price (USD)
Zinc (Zn)	1.10 USD/lb (approx. 2,425 USD/t)
Copper (Cu)	3 USD/lb (approx. 6,613 USD/t)
Silver (Ag)	19.50 USD/oz
Gold (Au)	1,300 USD/oz
CAD/USD	1.28 USD

#### 19.1.1 Zinc Concentrate

The average annual production of zinc concentrates at Horne 5 is projected to be approximately 74,000 t for the full years of operation over the life of mine.

The projected assays for the zinc concentrate shown in Table 19-2 were based on laboratory flotation testwork studies (Locked Cycle Test 23) and modelled metallurgical recoveries adjusted for the LOM plan as described in Chapter 16.

Table 19-2: Indicated zinc concentrate assays

Element	Unit	Grade	Element	Unit	Grade
Zn	%	52	As	%	<0.001
Au <sup>(1)</sup>	g/t	1.5 – 2.1	Sb	%	0.001
Ag <sup>(1)</sup>	g/t	100 – 200	Cl	g/t	<200
Fe	%	8.08	F	g/t	<100
Cd	%	0.18	MgO	%	0.06
Co	%	<0.002	Mn	%	0.03
Cu	%	0.51	Ni	%	<0.002
Hg	g/t	11	SiO <sub>2</sub>	%	2.18
Pb	%	0.18	Sn	%	0.012

<sup>(1)</sup> Projected precious metal assays based on the LOM plan and modelled recoveries

Based on the assays set out in Table 19-2, the Horne 5 zinc concentrate will be suitable for most zinc smelters. However, as not all zinc smelters are capable of recovering and thus paying for precious metals in zinc concentrate, the final destination for the high gold and silver Horne 5 zinc concentrate will very much depend on smelter recovery capabilities and prevailing logistics costs to different potential buyers. Although the concentrate is relatively clean, minor penalties may be imposed due to the presence of certain deleterious elements.

For the purposes of Project evaluation, the zinc concentrate sales terms presented in Table 19-3 were used in derivation of the NSR.

Table 19-3: Zinc concentrate sales terms used in derivation of the NSR

Payable Metals	
Zinc	85% of the Zn content, subject to a minimum deduction of 8 units
Silver	No payable
Gold	No payable
Treatment Charge	2020: 205 USD/t
	2021: 215 USD/t
	Long-term: 225 USD/t
Penalties Allowance	0.15 USD/t
Freight & Allowances	69.62 USD/t

### 19.1.2 Copper Concentrate

The average annual production of copper concentrates at Horne 5 is projected to be approximately 49,000 t over the full years of operation of the life of mine.

The projected assays for the copper concentrate shown in Table 19-4 were based on laboratory flotation testwork studies (Locked Cycle Tests 16 and 22) and modelled metallurgical recoveries adjusted for the LOM plan as described in Chapter 16.

Table 19-4: Indicated copper concentrate assays

Element	Unit	Grade	Element	Unit	Grade
Cu	%	16	Cd	%	<0.0002
Au <sup>(1)</sup>	g/t	58 - 85	Cl	ppm	<200
Ag <sup>(1)</sup>	g/t	310 - 730	F	ppm	200
Fe	%	31.6	Hg	ppm	3
S	%	37.6	MgO	%	0.5
Pb	%	0.19	Mo	%	<0.005
Zn	%	3.5	Ni	%	<0.002
As	%	0.003	Se	ppm	300
Sb	%	<0.001	SiO <sub>2</sub>	%	4.23
Bi	%	<0.01	Te	ppm	300

<sup>(1)</sup> Projected precious metal assays based on the LOM plan and modelled recoveries

Based on the assays set out in Table 19-4, the Horne 5 copper-gold concentrate will be suitable for copper smelters within the Horne 5 primary geographical catchment area. Although copper grades are projected to be lower than levels commonly found in standard copper concentrates, the high projected gold and silver grades will be attractive to buyers. Furthermore, the Horne 5 copper concentrate also contains very low levels of deleterious elements commonly found in copper concentrates, such as arsenic (“As”), antimony (“Sb”) and bismuth (“Bi”), making it a good blend feed. Nonetheless, minor penalties may be imposed due to the presence of other impurities.

For the purposes of Project evaluation, the copper concentrate sales terms presented in Table 19-5 were used in derivation of the NSR:

Table 19-5: Copper concentrate sales terms used in derivation of the NSR

Payable Metals	
Copper	96.5% of the Cu content, subject to a minimum deduction of 1.2 units
Gold	97% of the Au content, subject to a minimum deduction of 1 g/t
Silver	90% of the Ag content, subject to a minimum deduction of 30 g/t
Treatment Charge	85.00 USD/t
Copper Refining Charge	0.085 USD/payable lb Cu
Price Participation	Nil
Gold Refining Charge	5.00 USD/payable oz Au
Silver Refining Charge	0.50 USD/payable oz Ag
Penalties Allowance	1.00 USD/t
Freight & Allowances	73.00 USD/t

## 19.2 Gold Doré Sales

The doré produced at the mine will be shipped to a precious metals refinery for recovery of the gold and silver into high purity bars meeting the minimum London Bullion Market Association (“LBMA”) delivery standards. Average annual bullion production is estimated at 123,000 oz for gold and 1,042,000 oz for silver, considering full production years. These figures exclude the amounts of gold and silver reporting to the base metal concentrates. With these included, the average annual production figures increase to approximately 227,000 oz for gold and 2,118,000 oz for silver.

For the purposes of Project evaluation, the doré terms presented in Table 19-6 were used in derivation of the NSR:

Table 19-6: Doré terms used in derivation of the NSR

Payable/Returnable Metals	
Gold	100% of the Au content
Silver	100% of the Ag content
Treatment Charge (including deductions, transportation & insurance)	5.00 USD/oz doré
Penalties	Nil



### 19.3 Calculation of Net Metal Payment from Product Buyers

The expected net payable metal contents and costs for smelting and refining the mine’s end products were established on the basis of the treatment terms assumptions set out above.

Table 19-7 presents the average mass balance derived from the metallurgical projections presented in Chapter 13, as applied to the yearly mine plan feed grades.

Table 19-7: Average LOM mass balance

Product	Mass (%)	Au		Ag		Cu		Zn	
		Grade (g/t)	Distribution (%)	Grade (g/t)	Distribution (%)	Grade (%)	Distribution (%)	Grade (%)	Distribution (%)
Feed	100.0	1.44	100.0	14.14	100.0	0.17	100.0	0.77	100.0
Cu concentrate	0.87	66.4	39.97	526	32.2	16.0	81.9	4.0	4.5
Zn concentrate	1.28	1.86	1.66	128	11.8	0.33 <sup>(1)</sup>	2.5 <sup>(1)</sup>	52.0	86.2
Py concentrate	42.2	1.77	52.2	15.9	47.5	0.03 <sup>(1)</sup>	8.5 <sup>(1)</sup>	0.11 <sup>(1)</sup>	6.0 <sup>(1)</sup>
Py tails	55.6	0.16	6.1	1.6	8.6	0.02 <sup>(1)</sup>	7.1 <sup>(1)</sup>	0.05 <sup>(1)</sup>	3.3 <sup>(1)</sup>

<sup>(1)</sup> Values are estimates only since assays for non-payable metals not tracked regularly in testwork.

Table 19-8 shows the resulting net payable metal contents, as derived when applying the average LOM mass balance presented in Table 19-7, and based on the smelting contract assumptions used for the Project.

Table 19-8: Calculation of net payable metal content in products

Product	Flotation Rec. (%)	Leach Rec. <sup>(1)</sup> (%)	Payable (%)	Net Paid (% LOM)
<b>Au</b>				
Cu concentrate	40.0	n/a	97.0	38.7
Zn concentrate	1.7	n/a	0	0
Py concentrate	52.2	85.0	100.0	44.7
Py tails	6.1	78.6	100.0	4.7
<b>TOTAL</b>	<b>100.0</b>		<b>96.9</b>	<b>88.1</b>
<b>Ag</b>				
Cu concentrate	32.2	n/a	89.9	29.0
Zn concentrate	11.7	n/a	0.0	0.0
Py concentrate	47.5	77.6	100.0	36.9
Py tails	8.6	65.2	100.0	5.6
<b>TOTAL</b>	<b>100.0</b>		<b>84.0</b>	<b>71.5</b>



Product	Flotation Rec. (%)	Leach Rec. <sup>(1)</sup> (%)	Payable (%)	Net Paid (% LOM)
<b>Cu</b>				
Cu concentrate	<b>81.9</b>	n/a	92.5	<b>75.8</b>
<b>Zn</b>				
Zn concentrate	<b>86.2</b>	n/a	84.6	<b>72.9</b>

<sup>(1)</sup> Including CIP solution losses.

#### 19.4 Net Treatment and Refining Charges

The costs associated with the treatment and refining charges (“TC/RC”) for each of the copper and zinc concentrates, based on the terms assumptions as set out in Section 19.1 and the average mass balance presented in Table 19-7, amount to 2.00 USD/t of plant feed processed for the copper concentrate and 4.75 USD/t for the zinc concentrate. These amounts exclude the related refining charges for the gold and silver contents in the concentrates.

#### 19.5 Sales and Marketing Contracts

No contracts are currently in place for any production from the Project. It should be noted that most precious metals concentrates are traded on the basis of term contracts. These frequently run for terms that have durations from one year to 10 years, although many long-term contracts are treated as evergreen arrangements that can continue indefinitely with periodic renegotiation of key terms and conditions. Glencore Canada has rights of first refusal with respect to purchase or toll process all or any portion of the concentrates and other mineral products from the Horne 5 Project.

#### 19.6 Other Contracts

As of the effective date of this Report, Falco has awarded a number of equipment and service contracts as part of the pre-construction activities of the Project. The significant contracts are summarized in Table 19-9 below:

Table 19-9: Significant Project contracts

Equipment/Service	Supplier	Estimated Completion Date	Press Release Reference
Overall engineering, procurement, supply, performance services and installation of the Mine hoisting systems (production hoist, an auxiliary hoist and a service hoist)	ABB Canada	Q4 2018	<a href="http://www.falcores.com/English/news/news-details/2017/Falco-Secures-Hoisting-Systems-for-the-Horne-5-Project/default.aspx">http://www.falcores.com/English/news/news-details/2017/Falco-Secures-Hoisting-Systems-for-the-Horne-5-Project/default.aspx</a>
Head Frame and Hoist Room Engineering	WSP Canada Inc.	Q1 2018	N/A
Water Treatment Plant Engineering	BBA Inc.	Q4 2017	N/A
Water Treatment Equipment (partial)	FLSmith STT Environment	Q1 2018	N/A

## 20. ENVIRONMENTAL STUDIES, PERMITTING, AND SOCIAL OR COMMUNITY IMPACT

*Pursuant to an agreement between Falco and a Third Party, Falco owns rights to the minerals located below 200 metres from the surface of mining concession CM-156PTB, where the Horne 5 deposit is located. Falco also owns certain surface rights surrounding the Quemont No. 2 shaft located on mining concession CM-243. Under the agreement, ownership of the mining concessions remains with the Third Party.*

*In order to access the Horne 5 Project, Falco must obtain one or more licenses from the Third Party, which may not be unreasonably withheld, but which may be subject to conditions that the Third Party may require in its sole discretion. These conditions may include the provision of a performance bond or other assurance to the Third Party and the indemnification of the Third Party by Falco. The agreement with the Third Party stipulates, among other things, that a license shall be subject to reasonable conditions which may include, among other things, that activities at Horne 5 will be subordinated to the current use of the surface lands and subject to priority, as established in such party's sole discretion, over such activities. Any license may provide for, among other things, access to and the right to use the infrastructure owned by the Third Party, including the Quemont No. 2 shaft (located on mining concession CM-243 held by such Third Party) and some specific underground infrastructure in the former Quemont and Horne mines.*

*Furthermore, Falco will have to acquire a number of rights of ways or other surface rights in order to construct the TMF and associated pipelines.*

*While Falco believes that it should be able to timely obtain the licenses from the Third Party and to acquire the required rights of way and other surface rights, there can be no assurance that any such license, rights of way or surface rights will be granted, or if granted will be on terms acceptable to Falco and in a timely manner.*

*Falco also notes that the timeline of activities described in this Report, and the estimated timing proposed for commencement and completion of such activities, is subject at all times to matters that are not within the exclusive control of Falco. These factors include the ability to obtain, and to obtain on terms acceptable to Falco, financing, governmental and other third party approvals, licenses, rights of way and surface rights (as described in this Chapter 20 and in Chapters 16 and 18).*

*Although Falco believes that it has taken reasonable measures to ensure proper title to its assets, there is no guarantee that title to any of assets will not be challenged or impugned.*

*The foregoing disclaimer hereby qualifies in its entirety the disclosure contained in this Chapter 20 of this Report.*

The Horne 5 Project environmental baseline provided in this chapter was collected from various databases and existing data collected for other projects located in the area as well as from field inventories conducted in 2016 and to be completed in 2017.

The sources of information used to describe the environment and social components are specified in each of the following sections.

Numerous characterization programs were initiated in 2016:

- Groundwater quality;
- Hydrology, surface water quality and sediment quality;
- Soil quality at the Horne 5 Mining Complex site;
- Biological components (vegetation and wetlands, terrestrial fauna, bats, avian fauna, herpetofauna, fish and habitats and species at-risk);
- Air quality;
- Ambient noise and vibration levels;
- Social components;
- Landscape and visual impacts.

The site where tailings are managed and stored was chosen late in fall 2016, therefore most of the field characterization and measurements done cover only the Horne 5 Mining Complex area. Additional field surveys and inventories along the pipelines route and the proposed TMF site will be completed in 2017 to comply with the environmental assessment requirements.

Additionally, some consultation/information activities are ongoing and will be required from this stage of the Project until its completion.

## 20.1 Environmental Studies

### 20.1.1 General Description

The Horne 5 Mining Complex, including the Quemont No. 2 shaft, is located in the "Noranda-Nord" industrial park, on the mining concession CM-243. The Horne 5 deposit is on the mining concession CM-156PTB. These mining concessions are held by the Third Party.

The proposed TMF site is located in the D'Alembert sector, approximately 11 km north of the Horne 5 Mining Complex.

#### 20.1.1.1 Horne 5 Mining Complex

The property where Falco conducts its activities was formerly owned by Service Sani-Tri (“Sani-Tri”), which specialized in waste management recycling. Sani-Tri also provided collection and sorting services of recyclable materials. Following the closure of this company, the city of Rouyn-Noranda rented the property and its buildings to Falco for five years with a purchase option. Recyclable waste, hazardous waste and construction debris are or have been present on the property. Demolition and renovations were carried out on-site.

Adjacent properties consist of commercial and industrial establishments as well as some storage sites for various materials. The adjacent northern property is the *Centre de Formation Professionnelle Quémont* of the *Commission Scolaire de Rouyn-Noranda*. It is the only institutional building in the area. Directly in front of the training centre is an asphalt plant owned by the Sintra group. The eastern property also belongs to Sintra. Their main office is located there, along with some storage areas. The property to the west belongs to the Eco-Centre Arthur-Gagnon. The above mentioned properties, located on the former Quemont mining site, will have to be acquired to form the future Horne 5 Mining Complex.

The property bordering to the south of the Horne 5 Mining Complex is the Horne smelter industrial complex and old tailings management facilities (“OTMF”) managed by a local industry. These OTMF sites have not been restored. Within a 400 metres radius, the Horne 5 Mining Complex is surrounded by non-covered tailings identified as Quemont 1 OTMF to the south, east and north-east as well as the Osisko North Basin which is an industrial water pond used by the Horne smelter.

The Horne smelter industrial complex is located approximately 350 m to the south of the Horne 5 Mining Complex, and a quarry site (site No: 32D06-18), operated by Sintra, is located approximately 550 m to the north-west.

The area is served by municipal water and sewer services and natural gas. According to the Hydrogeological Information System (“SIH”) of the MDDELCC, one well is located within a 1 km radius of the Project (700 m) at the junction of Marcel-Baril and Abitibi avenues. It was originally owned by Noranda Mines Ltd., and its current condition and use are unknown.

#### 20.1.1.2 Tailings Management Facility Site

Falco’s proposed TMF site is to be located approximately 11 km north-west from the Horne 5 Mining Complex, in the D’Alembert sector of Rouyn-Noranda. A description of the current site conditions is provided in Section 20.2.6.

The projected TMF site sits on a former mine site and on public lands. This former underground mine operated between 1964 and 1995. Operations ceased at the underground mine in 1976 and the use of its processing facilities ceased in 1995. There have been no mining activities since then.

***While Falco has been negotiating with the owner of the site, no agreement has been concluded yet for the acquisition of the required titles. Accordingly, information relating to the proposed TMF site and use thereof by Falco for its Horne 5 Project is expressly qualified by the foregoing disclaimer.***

The environmental restoration plan (Golder, 1998) for the site was submitted to the ministerial authorities in 1998. The plan was accepted and since then, progressive restoration works have been completed.

Along the proposed routing of the pipelines, mining titles (claims and mining concessions) are owned by Falco Resources Ltd., Resources Breakwater Ltd. (it was acquired by Nyrstar Ltd. In 2011), IAMGOLD, and others. The pipelines route would also cross many public and private lands. Rights of ways will have to be obtained from the land owners.

### 20.1.2 Physical Environment

The physical environment description of the Horne 5 Mining Complex area is based on these different sources of information:

- Public data base and documents;
- Information gathered from various governmental agencies as well as other private and public institutions;
- Studies and reports available from Falco;
- Aerial photographs, satellite images, maps and geomatic tools;
- Phase I environmental site assessment and Phase II environmental site assessment on the Horne 5 Mining Complex;
- On-site works from May to November 2016 to characterize the surface water quality in the mine site area;
- On-site works in July 2016 for the sediments quality in the watercourses, which may receive final effluent, contact or runoff water;
- Hydrogeological study on the Horne 5 Mining Complex (ongoing);
- Ambient air quality samplings in the mine site area;
- Ambient noise level measurements in the mine site area;
- Ambient vibrations level measurements in the mine site area.

### 20.1.2.1 Hydrology

#### Horne 5 Mining Complex

The mining site lies within the Osisko North Basin watershed. This basin is isolated from the Osisko Lake by a dike system and is used by the Horne smelter as a polishing pond. It receives runoff from the Horne smelter industrial complex as well as the runoff from Noranda 3, Noranda 2, Noranda 1 and Quemont 1 OTMF and water from Quemont 2 tailing pond. The discharge of the basin is the Osisko Creek, a tributary of the Rouyn Lake, which is part of the Outaouais River watershed via the Kinojévis River.

The receiving environment selected for the Horne 5 Mining Complex effluent during preproduction (initial dewatering) is the Dallaire watercourse, located approximately 5 km east from the Horne 5 Mining Complex. This watercourse takes its source in the Drolet Lake and lies within the Kinojévis River watershed. This effluent point may also be used, if necessary, during production phase without TMF. However, very little to no discharge of Horne 5 mine water to the environment is expected during this period, as process makeup water demand will exceed volume that may be recovered from underground.

In order to preliminary determine the impact on the receiving environment during the dewatering period, WSP Canada Inc. (2017a) evaluated the theoretical flow of the Dallaire watercourse. Impacts on the water level and on the flow of the watercourse were evaluated at different flood flow return periods as well as on low flow periods. Based on that evaluation, the dewatering flow would influence the flow and the water level during flood events of return periods of 0 to 2 years. However, the risks of flooding adjacent land and generating shore erosion are not expected.

The flow during the low flow periods will increase during dewatering and will result in higher water levels than usually observed during normal low flow periods, without the risk of flooding of adjacent land. All flows estimated remain under the flood return period of 0 to 2 years.

#### TMF Site

The proposed TMF site is located within two watersheds: Duprat and Vauze. These watersheds are both tributaries to Dufault Lake via the Duprat River and the Vauze Creek. Both watersheds are bordered by hills with moderate to steep slopes. The altitude varies between 417 m and 324 m. The waterbody north of the actual tailings ponds, and currently known as the Oxidation Pond 2 ("OX-2"), is a widening of the Vauze Creek created by the dams on site.

Vauze Lake is located upstream of the TMF site and covers an area of 0.13 km<sup>2</sup>. Its discharge flows into OX-2, which is controlled by Dam E of the TMF site. The OX-2 covers an area of 0.40 km<sup>2</sup>. Several watercourses and wetlands are located between Dam G (north-east end of the TMF site), the discharge point of the actual final effluent and Dufault Lake, along the 7.0 km of the Vauze Creek. The Dufault Lake is a major waterbody, used by the City of Rouyn-Noranda as a drinking water reserve, which covers more than 21 km<sup>2</sup>. Duprat Lake (Rouyn-Noranda's alternative drinking water reserve) is located about 2 km south-east of TMF site and Waite Lake is located about 500 m to the west.

A dozen watercourses, all part of the Dufault Lake watershed, will have to be crossed in order to install the pipelines. They will be installed mostly above ground, with underground segments for the rivers, wetland and road crossings.

The receiving environment selected for the discharge of the TMF final effluent during production with TMF is Waite Lake.

A risk analysis in case of pipeline and dikes failure, and the impact on the water level and on the flow of the receiving environment for the final effluent, will be evaluated in the environmental impact assessment study.

Section 20.2.8 details the water management strategy during each phase of the Project (preproduction, production with and without TMF).

#### 20.1.2.2 Surface Water and Sediment Quality

##### Horne 5 Mining Complex

A surface water quality sampling program was undertaken in 2016 to determine the actual state of the surface water quality of the main watercourses found near the Horne 5 Mining Complex, or potentially affected by the future mining operations. Surface water and sediments of the following watercourses were sampled respectively at least 6 times during a year period and once (five stations per watercourse), as required by the *Guide de caractérisation physicochimique de l'état initial du milieu aquatique avant l'implantation d'un projet industriel* (MDDELCC, 2015):

- Watercourse 1: located north of the mining site, flowing across the Noranda golf course, onto the Quemont 1 OTMF and discharging in the Osisko North Basin;
- Watercourse 2: a ditch, tributary of a watercourse discharging into the Osisko North Basin, which flows across the mining site on its southern-east end;
- Osisko Creek: originates from the Osisko North Basin and is a mining effluent monitored by the Horne smelter;
- Dallaire watercourse: originates from Drolet Lake and discharges in Rouyn Lake.



All samples were analyzed for usual physicochemical parameters, nutrients, major ions, metals, organic molecules and coliforms. Results were compared to MDDELCC surface water quality criteria (MDDELCC, 2016) for both protection of aquatic fauna from long-term exposure to contaminants (“CVAC”) and water contamination (“CPC(EO)”).

All four watercourses sampled showed numerous exceedances of the provincial water protection criteria (Table 20-1), indicating degraded water quality in all cases.

Table 20-1: Exceedance of water quality protection criteria in the Horne 5 Mining Complex vicinity

Watercourse	Total number of exceedances (for any analyzed parameter)	
	CPC(EO)	CVAC
Watercourse 1	42	30
Watercourse 2	40	22
Osisko Creek	25	22
Dallaire	23	27

All four watercourses also showed numerous exceedances of sediment quality (threshold effect level and rare effect level; EC and MDDEP, 2007) for the parameters for which criterion exists (metals only).

### TMF Site

Surface water sampling were taken in late 2016 for the Vauze Creek and Duprat River, as well as in the Dufault Lake. A surface water and sediment sampling program complying to the requirements of the *Guide de caractérisation physicochimique de l'état initial du milieu aquatique avant l'implantation d'un projet industriel* (MDDELCC, 2015) and aiming to describe the current quality conditions will have to be completed in 2017 for all the watercourses and waterbodies potentially affected by the Project, hence all of the watercourses crossed by the pipelines route and the watercourses and waterbodies in the TMF site surroundings.

### 20.1.2.3 Hydrogeology

#### Horne 5 Mining Complex

Four hydrostratigraphic units were identified at the mining site, from the ground surface:

- Unit 1: tailings;
- Unit 2: deep-water sediments composed of clay and silt rhythms;
- Unit 3: a granular deposit of glacial origin (till);
- Unit 4: the bedrock.

The thickness of surficial deposits generally ranges from 10 m to 20 m and between 20 m and 40 m along the south border of the Horne 5 Mining Complex. In the Horne smelter complex, located on a high topographic, surficial deposits are generally less than 10 m thick (Golder, 2017a).

Based on the information in the hydrogeological study (Golder, 2017a), public data and geological reports, the bedrock is a Class III aquifer.

The average hydraulic conductivity of the first 130 m was evaluated at  $6 \times 10^{-8}$  m/s with values ranging from  $1 \times 10^{-8}$  m/s to  $2 \times 10^{-7}$  m/s. Beyond 130 m, the average hydraulic conductivity decreases by two orders of magnitude, i.e. to a value of  $6 \times 10^{-10}$  m/s with values ranging from  $1 \times 10^{-10}$  m/s to  $3 \times 10^{-9}$  m/s (Golder, 2017a). Tests carried out in intervals intersecting the Horne fault showed no significant increase in hydraulic conductivity.

The depth of water levels at the mine site varies from 0.36 m to 18.65 m.

During the preproduction dewatering, the groundwater will come from two distinct sources: volumes stored in existing galleries and infiltrations from the bedrock. Volumes of water to be pumped during dewatering are presented at Section 16.4.

#### TMF Site

A brief desktop review of existing hydrogeological data of the Norbec site is presented in Section 20.2.6.5 of this document. A hydrogeological study in this area will be completed in 2017 to fulfill the environmental assessment requirements.

### 20.1.2.4 Groundwater Quality

#### Horne 5 Mining Complex

Following the drilling and installation of nine observation wells in the overburden and shallow bedrock at four different locations at the Horne 5 Mining Complex, a groundwater sampling campaign was completed in December 2016 to obtain baseline groundwater quality in the vicinity of the planned process plant. Groundwater samples were analyzed for metals, petroleum hydrocarbons C<sub>10</sub>-C<sub>50</sub>, volatile organic compounds, polycyclic aromatic hydrocarbons, phenolic compounds, polychlorinated biphenyls, phthalates, dioxins and furans, sulphur, sulphide and ions (sulphates, chlorides, bromide, fluoride, thiosulfate, alkalinity, hardness, nitrite, nitrate, nitrogen and ammonia, total phosphorus, total dissolved solids, total cyanide, free cyanide, thiocyanate and cyanate). The analytical results were compared to the applicable provincial criteria indicated in the MDDELCC *Guide d'intervention* (Beaulieu, 2016).

Concentrations in the groundwater samples were detected at a level above the comparison criteria (drinking water and seepage in surface water) in at least one sample for the following parameters: non-chlorinated benzene compounds: 2,4-dinitrotoluene; metals: silver ("Ag"), aluminum ("Al"), arsenic ("As"), cadmium ("Cd"), copper ("Cu"), mercury ("Hg"), manganese ("Mn"), sodium ("Na"), nickel ("Ni"), antimony ("Sb"), zinc ("Zn"); inorganic parameters: chloride ("Cl") and sulphides ("H<sub>2</sub>S") and dioxins and furans: sum of chlorodibenzodioxins and chlorodibenzofurans expressed as toxic equivalents 2,3,7,8-TCDD. The observation wells used to define this preliminary baseline could be resampled during the mine construction period to increase the database of analytical results representative of groundwater quality prior to the operation of the Mine. The current single sample results together with all of the analytical results to be obtained later will therefore represent the baseline groundwater quality prevailing at the site before the start of Mine operations.

#### TMF Site

No recent groundwater quality information is available at this stage for the TMF site. A groundwater quality characterization program in this area will be initiated in 2017 to fulfill the environmental assessment requirements.

### 20.1.2.5 Soil Quality

#### Horne 5 Mining Complex

A soil characterization program was carried out at the Horne 5 Mining Complex between November and December 2016. As mentioned in Section 20.1.1, the "Noranda-Nord" industrial park was established on OTMF from the former Quemont and Horne mines. Moreover, it is not possible to confirm the origin of the filling material used to cover the tailings.

The ongoing Phase II environmental site assessment will detail the contamination level of the material in place. Preliminary results show exceedance of the industrial criteria (C criteria) from the *Guide d'intervention* (Beaulieu, 2016) mainly for copper, zinc and sulfur.

#### TMF Site

The Norbec site was partially rehabilitated by the actual owners. A characterization program will be carried out at the TMF site to fulfill the environmental assessment requirements.

### 20.1.2.6 Air Quality

#### Horne 5 Mining Complex

According to the city of Rouyn-Noranda (Ville de Rouyn-Noranda, 2015a), air quality in the Rouyn-Noranda region is partially influenced by smog occurrences from Southern Ontario and the Northern United States. Locally, the main sources atmospheric contaminants are wood burning for heating, forest fires, industrial emissions and transportation. The two main contaminants of interest identified by the city in their development plan are arsenic and lead (Ville de Rouyn-Noranda, 2015a). The impact of these emissions is mainly observed on the Notre-Dame neighbourhood in the Vieux-Noranda (Ville de Rouyn-Noranda, 2015a). These emissions will have to be taken into account in the environmental background of the Project.

The MDDELCC has established an Air Quality Monitoring Program in 1970, which now includes 48 municipalities. There are five stations located in the city of Rouyn-Noranda<sup>1</sup>. The results from these stations are grouped and analyzed to establish an Air Quality Index (“AQI”). There are two areas in the city of Rouyn-Noranda where an AQI is calculated: Centre-Ville and Montée du Sourire. Table 20-2 presents annual statistics since 2010 of the two areas, as well as a general index for the Abitibi region. These numbers highlight the limited air quality in the Rouyn-Noranda region, particularly in the downtown area where air quality was qualified as bad on average 65 days per year between 2010 and 2014 (based on Table 20-2 data).

In order to better quantify air quality in the immediate vicinity of the Horne 5 Project, an air quality sampling program (particle and metal concentrations) was conducted in 2016 at three measurement stations located near the Horne 5 Mining Complex. The location of these stations and the sampling program methods were selected in order to allow for these data to be used for establishing the air quality baseline used for the environmental impact assessment work and to verify if air pollutant concentrations meet the Clean Air Regulation (“CAR”) applicable norms and criteria. The three selected stations were respectively located at the Noranda golf course, the Horne 5 Mining Complex and the Vieux-Noranda neighbourhood.

Result highlights of the 2016 air quality monitoring program are presented hereafter.

- Particle concentrations:
  - Total particle concentration (“PTS”) exceeded the CAR standard (120 µg/m<sup>3</sup>) on only two occasions, at Noranda golf course only, during the monitoring period.
  - For fine particle concentration (PM<sub>2.5</sub>), only a single overrun of the CAR standard (30 µg/m<sup>3</sup>) was measured at the Horne 5 Mining Complex.

---

<sup>1</sup> MDDELCC: [http://www.mddelcc.gouv.qc.ca/air/programme\\_surveillance/index.asp](http://www.mddelcc.gouv.qc.ca/air/programme_surveillance/index.asp) [Consulted May 2017].

- Even if no CAR standard is applicable, respirable particulate matter (PM<sub>10</sub>) was measured at two stations, the Vieux-Noranda area and the Noranda golf course. The average concentrations calculated for the two stations were comparable. However, the maximum measured at the Noranda golf station (88.9 µg/m<sup>3</sup>) was nearly four times the maximum measured at the station in Vieux-Noranda, south of the Project.
- Metal concentrations:
  - Arsenic (Vieux-Noranda and Quemont), barium (Vieux-Noranda and Quemont), copper (Vieux-Noranda and Quemont), manganese (Golf and Quemont), nickel (all three stations) and lead (Vieux-Noranda and Quemont) exceeded applicable CAR standards.
  - Three other metals were quantified in significant concentrations, but did not exceed the CAR standards, being beryllium (all three stations), cadmium (Vieux-Noranda and Quemont) and zinc (Golf).

These results are consistent with the provincial AQI data presented in Table 20-2, particularly on the basis of the numerous metals concentration measured that exceed the CAR standards. The Horne 5 Project design will have to take into account these high baseline pollutant concentrations in the project's vicinity to mitigate as much as possible a further degradation of air quality for the local population.

#### TMF Site

No air quality characterization programs have been initiated at this stage for the TMF site. An air quality monitoring program is currently being carried out to fulfill the environmental assessment requirements.

Table 20-2: Annual statistics of the AQI (number of days)

Area	Abitibi			Centre-Ville			Montée du Sourire		
	Good	Acceptable	Bad	Good	Acceptable	Bad	Good	Acceptable	Bad
2015 <sup>(1)</sup>	246	105	2	n/a	n/a	n/a	n/a	n/a	n/a
2014	220	121	1	169	122	51	183	153	27
2013	228	119	1	162	114	71	156	157	41
2012	227	114	2	169	103	68	160	161	44
2011	241	108	2	162	115	72	174	151	30
2010	244	102	4	175	111	63	184	141	33

<sup>(1)</sup> Detailed statistics for Centre-Ville and Montée du Sourire are not available for 2015.

Source: MDDELCC: <http://www.mddelcc.gouv.qc.ca/air/qa/statistiques/index.htm> [Consulted May 2017]

### 20.1.2.7 Noise and Vibrations

#### Horne 5 Mining Complex

Instruction Note 98-01 (MDDEP, 2006) indicates that the acceptable ambient noise level in industrial areas is  $70 \text{ dB}_A L_{qe, 24h}$ , day and night. Noise levels in the sensitive areas closest from the noise emission sources have to be evaluated to ensure noise criteria are respected in these zones.

An ambient noise level baseline has been completed in 2016 for the Horne 5 Mining Complex. Continuous noise measurements were taken at seven monitoring stations for three periods of two weeks:

- B1: near the house at 2010, Saguenay Street, about 800 m north-west of the mine site;
- B2: northern limit of the mine site, south-west of Noranda golf course;
- B3: 70, Laurier Street, about 1,500 m south-west of the mine site, and 400 m and 30 m west of the Horne smelter and the rail road, respectively;
- B4: north-west of the house at 35, Carter Avenue, about 1,000 m and 100 m south of the mine site and Horne smelter, respectively;
- B5: south of the building located at 2518, Saguenay Street, about 2.2 km north-east of the mine site;
- B6: east of the Lemay-Juteau pavilion of the *Centre intégré de santé et des services sociaux* (CSSS) de l'Abitibi-Témiscamingue, about 1,800 m south-west of the mine site;
- B7: in the industrial zone where the Horne 5 Project is planned.

The minimum residual noise levels measured varied from 31 dBA to 46 dBA at night and from 37 dBA to 48 dBA during the day. As a result, they were predominantly below the maximum acceptable sound levels according to the sound criteria of Instruction Note 98-01 for these types of zones.

During the day at the measurement stations B1, B5 and B3, the noise levels of residual noise were higher than those prescribed by the Instruction Note 98-01 for these types of zones. The measured noise levels of the residual noise thus become the criteria to be respected at these stations (see Table 20-3).

Table 20-3: Measured sound level and applicable noise criteria

Sampling Station	Zone	Instruction Note 98-01 Criteria (dBA) <sup>(1)</sup>		Minimum Sound Level Measured (L <sub>Aeq, 1h minimum</sub> ) <sup>(2)</sup>		Applicable Sound Criteria (dBA) <sup>(1)</sup>	
		Day	Night	Day	Night	Day	Night
B1	I	45	40	48	41	48	41
B2	III	55	55	37	31	55	55
B3	I	45	40	41	46	45	46
B4	II	50	45	41	38	50	45
B5	I	45	40	47	41	47	41
B6	II	50	45	48	40	50	45
B7	IV	70	70	45	42	70	70

<sup>(1)</sup> Equivalent to the minimum noise level measured if higher than the *Instruction Note 98-01* criteria.

<sup>(2)</sup> Sound levels rounded to 1dBA

Falco will implement a noise monitoring program to monitor the impacts of the Project on the surrounding environment.

Vibrations might be created by dynamiting operations needed to extract rock on a daily basis from the Horne 5 deposit. Therefore, to establish an initial assessment of the current conditions and to prepare a monitoring program, an ambient vibration level baseline has been realized in 2016 in the Horne 5 Mining Complex.

This baseline was carried out by continuous measurements with seismographs during three periods of two weeks each at 11 stations (only six stations during the first period).

The location of these stations was chosen to represent the vibration baseline in residential areas and close to sensible receptors (CSSS de l'Abitibi-Témiscamingue, Osisko North Basin dike, Quemont 2 TMF dike, etc.). Some of these stations were the same used for the ambient noise level baseline:

- Vib01: near the house at 2010, Saguenay Street, about 800 m north-west of the mine site;
- Vib02: northern limit of the mine site, south-west of Noranda golf course;
- Vib03: 70, Laurier Street, about 1,500 m south-west of the mine site, and 400 m and 30 m west of the Horne smelter and the rail road, respectively;
- Vib04: north-west of the house at 35, Carter Avenue, about 1,000 m and 100 m south of the mine site and Horne smelter, respectively;
- Vib05: on the west side of Saguenay Street, near Notre-Dame cemetery, about 1,200 m west of the mine site;



- Vib06: at 225, Perreault Est Street, near Élizabéth-Bruyère centre and on the south side of Osisko Lake, about 2 km south of mine site;
- Vib07: in the industrial zone where the Horne 5 Project is planned;
- Vib08: east to the Lemay-Juteau pavilion of CSSS de l'Abitibi-Témiscamingue, about 1,800 m south-west of the mine site;
- Vib09: south of the building located at 2518, Saguenay Street, about 2.2 km north-east of the mine site;
- Vib10: on the Quemont 2 OTMF dike, about 1,000 m north-east of the mine site;
- Vib11: on the dike between Osisko North Basin and Osisko Lake, about 1,000 m east of the mine site.

Vibrations measured throughout the monitoring were generally low. The average values of peak vector sum measured are under 0.2 mm/s, hence generally not perceptible by humans. While the minimal vector sums recorded at all stations in each of the periods remained very low ( $\leq 0.088$  mm/s), maximum vector peak sums varied between 0.156 mm/s and 6.549 mm/s. The station Vib03, which is strongly influenced by the presence of the railway located some 30 m to the east, recorded the highest maximal peak vector sums during each measurement period.

According to the Directive 019, a monitoring network of ground vibration and air pressure must be installed near homes or artesian wells when mining activities take place within 1 km from a point of impact. For an underground mining operation, within the first 100 m of exploitation below the surface, the maximal allowable vibration varies between 12.7 mm/s and 25 mm/s depending on the ground vibration frequency. At 100 m below the surface, the maximal allowable vibration is 12.7 mm/s. Finally, blasting between 19:00 and 07:00 must be at a fixed time and the population located at less than 1 km must be notified of the fixed blasting schedule and any changes made to it.

#### TMF Site

No ambient noise level or vibration baseline has been initiated at the TMF site. A noise monitoring program will be completed in 2017 to fulfill the environmental assessment requirements. No vibration issue is expected in this area.

### 20.1.3 Biological Environment

This section provides information on the biological components that may represent a constraint should they be affected by the Project.

The sources of information used to describe these components include the following:

- Vegetation and wetlands: ecoforestry numerical data from *Ministère des Forêts, de la Faune et des Parcs* (“MFFP”) (previously *Ministère des Ressources naturelles et de la faune* (“MRNF”)), Rouyn-Noranda city data and Canards Illimités Canada data on wetlands, and on-site field inventories in May, July and August 2016 to validate wetlands presence in the surroundings of the Horne 5 Mining Complex and in the Dallaire watercourse area;
- Fish species and their habitat: data obtained from MFFP and on-site field inventories in May and June 2016 in the four watercourses sampled for the surface water quality baseline;
- Terrestrial fauna: public data obtained from MFFP;
- Amphibians: public data obtained from MFFP and on-site field inventories conducted around the Dallaire watercourse area;
- Birds: presence, migration and nesting documented from public data and many on-site field inventories conducted in 2016 in the surroundings of the Horne 5 Mining Complex and in the Dallaire watercourse. Birds in the TMF site and along the pipelines route were described from public data. Field inventories will be carried out in 2017;
- Bats: data obtained from *Réseau québécois d’inventaire acoustique de chauves-souris* and MFFP. An on-site field acoustic survey done in the surroundings of the Horne 5 Mining Complex and in the Dallaire watercourse area in 2016;
- Species at risk: data obtained from provincial and federal government and from on-site field inventories in the surroundings of the Horne 5 Mining Complex and in the Dallaire watercourse area in 2016.

These components and study areas are represented on Figure 20-1 for the Horne 5 Mining Complex and Figure 20-2 for the TMF site.



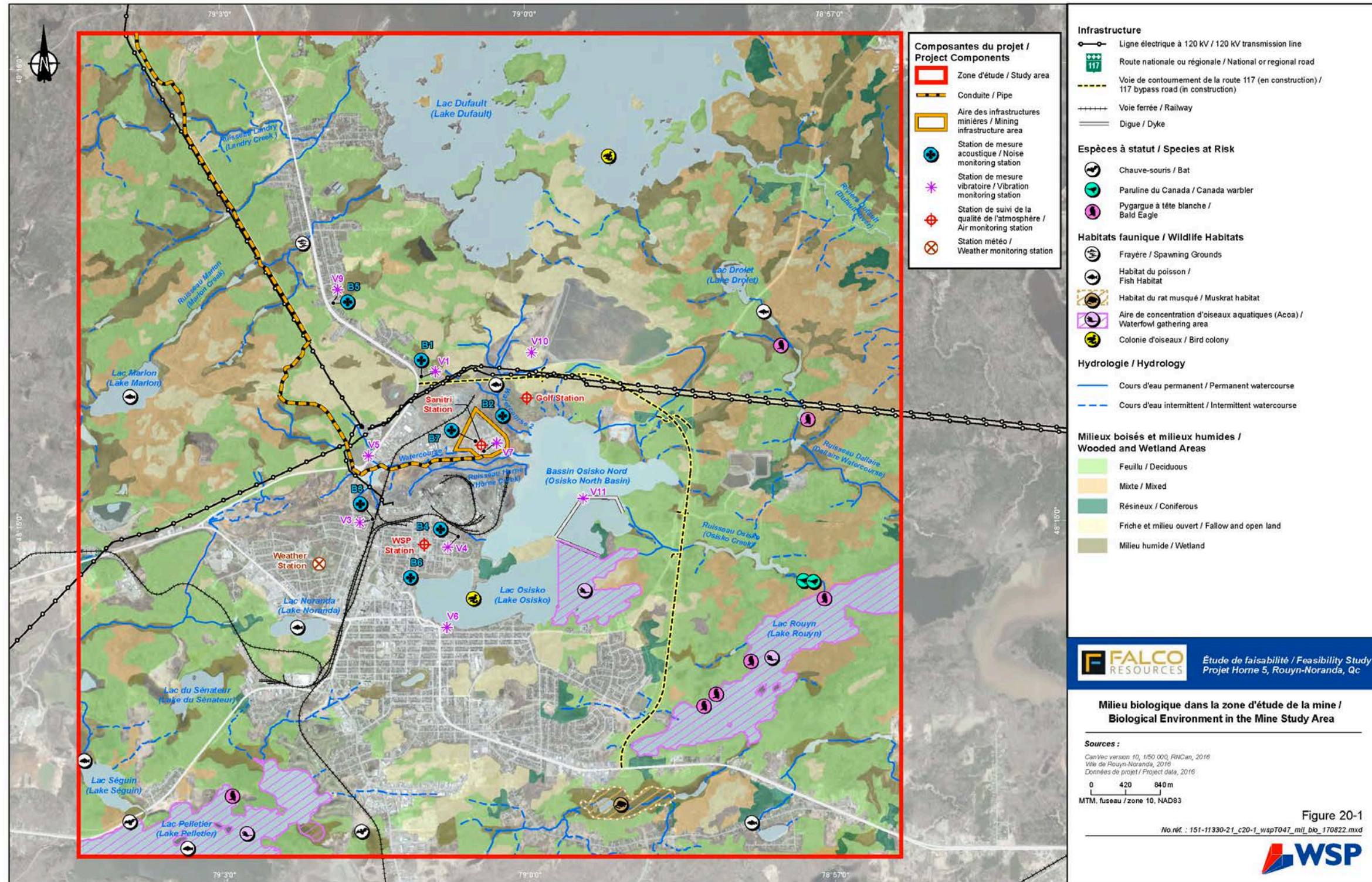

Figure 20-1: Environmental components and study areas – Horne 5 Mining Complex



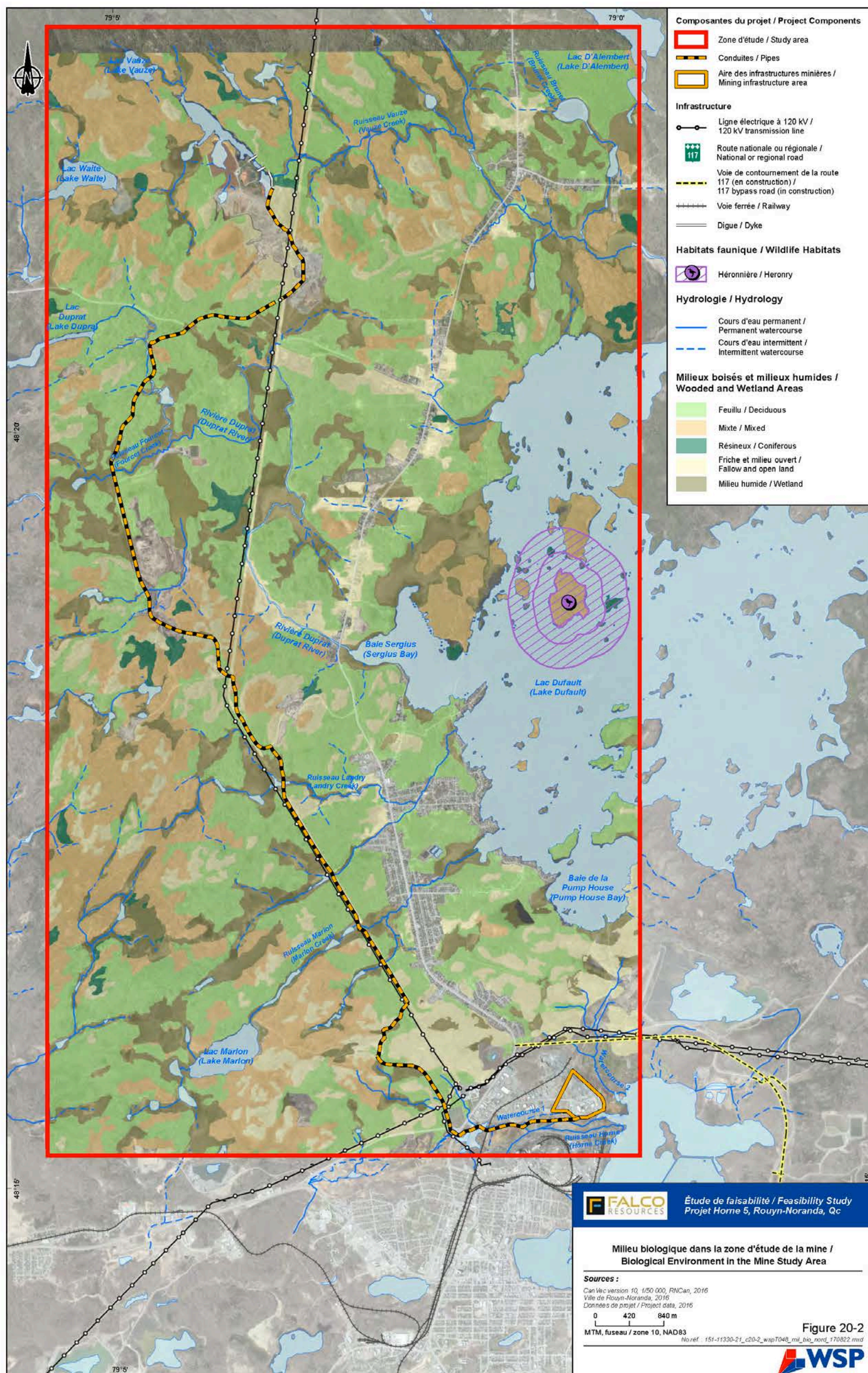

Figure 20-2: Environmental Components and Study Areas – TMF Site



### 20.1.3.1 Vegetation and Wetlands

#### Horne 5 Mining Complex

The immediate surrounding environment of the Horne 5 Mining Complex has been urbanized or industrialized. In the study area, the terrestrial vegetation is mostly deciduous or mixed stand.

The *Environmental Quality Act* (“EQA”) and regulations forbids any activities in wetlands (ponds, marsh, swamps or bog) unless a certificate of authorization is obtained. The overview of potential and confirmed wetlands in the study area was based on two sources of information: ecoforestry numerical data (32D06 and 32D07) and the Wetlands Managing Plan of the city of Rouyn-Noranda (Genivar, 2014).

The non-forested wetlands from the ecoforestry data are designated as wet barren areas, willow brush, flooded sites, bog or fen. The potential wetlands are polygons with either an imperfect drainage (5-6) or a typical forested stand associated with wetlands (e.g. black spruce-sphagnum stand).

In 2014, the city of Rouyn-Noranda presented its Wetlands Managing Plan for the different urban areas of the city (Genivar, 2014). Only the wetlands with a surface area higher than 1 ha were considered. They were identified by photo interpretation and a validation was performed on the field to confirm. However, no precise delineation was made.

In the study area (see Figure 20-1), wetlands are present and are mostly associated with water bodies or water courses.

#### TMF Site

The study areas for the TMF site and the pipelines route are almost entirely forested (467 ha or 54.5% of the study areas). Terrestrial vegetation is mostly deciduous or mixed stand, less than 60 years old. Some trees are 80 to 100 years old. Recent cuts, on small areas, cover about 32 ha (3.7%).

The study area (see Figure 20-2) also contains major wetlands (ponds, marsh, swamps and bogs). They cover about 105 ha (12.3%) of the study areas and are distributed uniformly in it.

Field inventories will be completed in 2017 along the pipelines route and at the TMF site to validate the wetlands delineation and to search for species at-risk habitats.

### 20.1.3.2 Wildlife and their Habitats

The *Conservation and Development of Wildlife Act* and the *Regulation Respecting Wildlife Habitats* regulate the conservation of wildlife and its habitat and states that no person may, in a wildlife habitat, carry on an activity that may alter any physical, biological or chemical component peculiar to the habitat of the animal or fish concerned.

#### Horne 5 Mining Complex

Information requests were addressed to the MFFP to validate the possible presence of protected wildlife habitat within the study area. Field inventories were also carried out in 2016 to identify potential habitats. The species at-risk and the potential habitats that were identified in the mine area are presented on Figure 20-1.

#### TMF Site

Information requests were also addressed to the MFFP to validate the possible presence of protected wildlife habitat and different species at the TMF site and along the pipeline route. Those identified are presented on Figure 20-2. Field inventories will be completed in 2017 in these areas to complete the data obtained from the government and identify the potential habitat losses.

### 20.1.3.3 Fish and their Habitats

Both federal and provincial governments regulate fish and their habitats. At the provincial level, MFFP regulates fish habitats by the *Regulation Respecting Wildlife Habitats*, as mentioned in the previous section. At the federal level, the *Metal Mining Effluent Regulations* (“MMER”) under the *Fisheries Act*, regulated by Fisheries and Oceans Canada, requires, among other things, any mining project to carry out an Environmental Effect Monitoring program before the beginning of the exploitation.

#### Horne 5 Mining Complex

The potential impacts of the Project on fish and their habitats at the Horne 5 Mining Complex are low. The two watercourses nearby are located outside of the project’s footprint. Water in these watercourses is of low quality, they are still considered as habitat and are thus protected. Any impact on these watercourses needs to be mitigated and any modification resulting in a loss of habitat will require compensation measures to prevent habitat destruction or serious harm to fish.

### TMF Site

Information requests were addressed to the MFFP to validate the presence of fish habitats within the study area of the TMF site and in the watercourses crossed by the pipelines route. Fish habitats were confirmed for some watercourses. Field inventories will be completed in 2017 to complement the information.

The waterbody existing at TMF site is considered fish habitat, though it is not currently supported by field data. As described in the Guidance for Proponents on the Federal Process for Designating Metal Mine Tailings Impoundment Areas, it is mandatory that natural waterbodies frequented by fish shall be avoided to the extent practicable for the long-term disposal of mine waste; and that mine waste shall be managed to ensure the long-term protection of Canada's terrestrial and aquatic environment.

Using a natural water body frequented by fish for mine waste disposal requires an amendment to the MMER, which is a federal legislative action. The MMER, enacted in 2002, were developed under subsections 34(2), 36(5) and 38(9) of the Fisheries Act to regulate the deposit of mine effluent, waste rock, tailings, low-grade ore and overburden into natural waters frequented by fish. These regulations, administered by Environment Canada ("EC"), apply to both new and existing metal mines. Schedule 2 of the MMER lists water bodies designated as tailings impoundment areas. A water body is added to that Schedule through a regulatory amendment.

If a water body is added to Schedule 2 of the MMER, Falco will develop and implement a fish habitat compensation plan in accordance with Section 27.1 of the Regulations. In any cases, a fish habitat compensation plan is required under federal or provincial legislation as applicable.

#### 20.1.3.4 Species at Risk and their Habitats

##### Horne 5 Mining Complex

The *Threatened or Vulnerable Species Act* and its regulations apply to threatened or vulnerable wildlife and plant species and their habitats. Information requests were addressed to the *Centre de données sur le patrimoine naturel du Québec* ("CDPNQ", 2015). No special-status species are identified in the study area. However, some at-risk "species are identified within the study area. Their locations are presented in Figure 20-1. Those species are:

- Birds: Paruline of Canada, Bald Eagle;
- Bats: little brown bat, silver bat, red bat and hoary bat.

### TMF Site and Pipelines Route

Information requests were also addressed to the CDPNQ to cover the area of the TMF site and the pipelines route.

If it is determined that the Project could impact a habitat where species at risk can potentially exist, field inventories were performed in 2017.

#### 20.1.3.5 Protected Areas

No established or planned protected areas are located in the study area of the Horne 5 Mining Complex, or the TMF site.

## 20.2 Ore, Waste Rock, Tailings and Water Management Strategy

### 20.2.1 Production Schedule and Tailings Streams

#### 20.2.1.1 Tailings and Waste Rock Production Schedule

The Horne 5 mine will be in operation for approximately 15 years at an average mill rate of 15,500 tpd over the LOM. Table 20-4 presents the available average LOM mill rate and total tailings production data.

Table 20-4: Average LOM mill rate and total tailings production

	Average LOM Ore Mill Rate and Tailings Production
Daily	15,500 tonnes
Annually	5,657,500 tonnes
<b>Total</b>	<b>80,896,876 tonnes</b>

Besides the ore, some waste rock will be excavated at Horne 5 and an estimated total of about 1.6 Mt of waste rock will be hoisted to the surface and transported to the TMF site. The schedule of waste rock to be hoisted at surface is presented in Table 20-5.

Table 20-5: Waste rock to be managed at surface

	2019	2020	2021
Quantity (tonnes)	489,142	920,889	221,361



### 20.2.1.2 Tailings Streams

The ore processing will result in the generation of two different tailings streams – the PFT and the PCT. Based on the current process flowsheet, the PFT and PCT streams represent about 63% and 37%, respectively, of the total process tailings production. As planned, both streams will be subjected to cyanide leaching for gold recovery followed by cyanide destruction in two separate cyanide destruction plants. Table 20-6 presents average total tailings tonnages per stream over the LOM.

Table 20-6: Total tailings production rate per stream

	Unit	Average LOM Ore Mill Rate and Tailings Production		
		PFT	PCT	Total
Annual Average	tpy	3,564,225	2,093,275	5,657,500
Total Tailings Production	Mt	50.9	29.9	80.9
% of Total	%	63	37	100

## 20.2.2 Geochemical Assessment

### 20.2.2.1 Ore, Tailings and Process Water

An independent study to define the geo-environmental properties of the ore and the tailings to be produced by the operations was carried out for the Project. The study assessed the acid rock drainage potential, the chemical composition, and the leaching potential of the ore and tailings at concentrations higher than the water quality criteria defined by the MDDELCC (Beaulieu, 2016). The results of this study are used to classify each waste stream according to Directive 019, which in turn are usually used to define waste disposal strategies that are protective of the environment.

Mineralization samples (massive sulphides and mineralized rhyolitic tuff) were collected and analyzed, as well as tailings and process water samples of the two metallurgical streams for the gold extraction. The two metallurgical streams include PFT and PCT. Analyses carried out on the samples consisted of acid base accounting, extractible metal analyses and static leachability tests using analytical protocols from the *Centre d'expertise en analyse environnementale du Québec* ("CEAEQ") as prescribed in Directive 019. Chemical analysis of the process water included a comprehensive suite of analyses after the samples had undergone cyanide destruction by Caro's Acid.

The summary of the ore and tailings geochemical characterization results is presented in Table 20-7. Based on these preliminary results, the ore and the tailings will require a management strategy on surface meeting recommendations of Directive 019, though the pyrite flotation tailings, which report low sulphur content, have not developed acidic conditions after 20 weeks of testing (URSTM, 2017), so a delay in the onset of acidic conditions can be expected. Different sulphur concentrations were observed in the tested PFT samples and further testing is underway for completion.

The process water sample from each tailings stream shows some exceedance of surface water criteria (“RES”), drinking water criteria and effluent criteria (Table 20-8). The process water (process plant discharge water) will need to be treated to meet the applicable water criteria before any discharge to the environment.

Table 20-7: Summary of the ore, tailings and process water geochemistry characterization results

Lithology	Number of Samples	Acid Generation Potential <sup>(1)</sup>	Leachable <sup>(1)</sup>	Process Waters (After SO <sub>2</sub> -Air)		
				> RES <sup>(2)</sup>	> Drinking Water <sup>(2)</sup>	> Effluent Directive 019 <sup>(3)</sup>
Massive Sulphides: Ore	2	PAG	Cd, Cu, Zn	-	-	-
Mineralized Rhyolitic Tuff: Ore	2	PAG	Cd, Zn	-	-	-
Pyrite Flotation Tails (PFT)	1	PAG	Cu, Pb	-	-	-
Pyrite Concentrate Tails (PCT)	1	PAG	Cd, Cu	-	-	-
Process Water –Pyrite Flotation Tailings after Caro’s Acid	Water	-	-	Hg, Ag, Cr, Cu, Se, total CN	Cr, Cu, Mn, Sb, Se	Cu, total CN
Process Water - Pyrite Concentrate Tailings after Caro’s Acid	Water	-	-	Hg, Ag, Cr, Cu, Se, Zn, total CN	As, Cr, Cu, Mn, Mo, Na, Ni, Sb, Se	Cu, total CN

(1) Following Directive 019 guidelines. Other parameters are regulated under Directive 019 (arsenic, lead, total cyanide, hydrocarbons and toxicity), but these are not expected to be exceeded.

(2) *Guide d'intervention Protection des sols et réhabilitation des terrains contaminés. Juillet 2016. Annexe 7 : Grille des critères de qualité des eaux souterraines; Résurgence dans l'eau de surface/Eau de consommation.*

(3) *Concentrations moyennes mensuelles acceptables pour l'effluent final (Acceptable Average Monthly Concentrations for Final Effluent), Directive 019 (MDDEP, 2012).*

#### 20.2.2.2 Waste Rock

An independent study to define the geo-environmental properties of the waste rock to be produced by the operations was carried out for the Project. The study assessed the acid rock drainage potential, the chemical composition, and the leaching potential of the waste rock lithology at concentrations higher than the water quality criteria defined by the MDDELCC (Beaulieu, 2016). The results of this study are used to classify each waste rock lithology according to Directive 019 guidelines, which is in turn generally used to define waste disposal strategies that are protective of the environment.

All the lithologies encountered between 0 m and 200 m from the Horne 5 mineralized zone were sampled (see Table 20-8). This represents the planned stope access and permanent installation (e.g., ramp, crusher, etc.) zones. Another area sampled was between the existing Quemont No. 2 shaft and the mineralized area to represent the waste material that will be generated to connect this main access to the underground operations and the mining area. The number of samples collected (listed in Table 20-8) were aimed at obtaining a representation of each waste unit mined during preproduction and production (minimum of three samples per unit). Analyses carried out on the samples consisted of acid base accounting, extractable metal analyses, and static leachability tests using analytical protocols from the CEAEQ as prescribed in Directive 019.

The summary of the waste rock geochemical characterization results is presented in Table 20-8. Based on the study to date, all waste rock lithologies should be considered potentially acid generating (“PAG”) (average sulphide content by lithology varies from 0.5% to 6.6%), with the possible exception of the basalt/andesite (average sulphide content of 0.3%). That lithology could be investigated further to verify its compositional variability and to validate the findings of this study on a larger number of samples. About 75% of the waste rock samples are not classified as leachable. The remaining 25% is classified as leachable for cadmium, copper and/or zinc. The leachable samples are found only in the Horne’s rhyolite and rhyolitic tuff. The Quemont rhyolite, diorite, and basalt/andesite are not classified as leachable. The four analyzed mineralization samples are classified as PAG and leachable.

Based on these preliminary results, the waste rock will require a management strategy on surface meeting recommendations of Directive 019, with the possible exception of the basalt/andesite waste rock if the non-PAG classification were to be confirmed.

Table 20-8: Summary of the waste rock geochemistry characterization results

Lithology	Number of Samples	Acid Generation Potential <sup>1</sup>	Leachable <sup>(1)</sup>
Quemont No. 2 Shaft Rhyolite: Waste Rock	3	PAG	-
Diorite: Waste Rock	3	PAG	-
Basalt/Andesite: Waste Rock	4	Uncertain	-
Horne's Rhyolite: Waste Rock	4	PAG	Cd, Cu, Zn
Rhyolitic Tuff: Waste Rock	7	PAG	Zn

<sup>(1)</sup> Following Directive 019 guidelines. Other parameters are regulated under Directive 019 (arsenic, lead, total cyanide, hydrocarbons and toxicity), but these are not expected to be exceeded.

### 20.2.3 Ore Management

The ore has been characterized as potentially acid generating and metal leaching.

During production, the ore will be stored and handled in a dedicated partially underground facility located within the Horne 5 Mining Complex. The ore will be delivered to the facility by a conveyor belt set in a shallow trench cut through the bedrock. The conveyor belt will be covered so dust and noise are mitigated. The facility itself will be located in a shallow silo built on the bedrock. It will be equipped with a sump in the reclaim tunnel to collect drainage water. Water from the ore will be managed within the underground facilities. The dome will be equipped with a fixe rooftop to ensure dust control.

The ore that will need to be temporarily stored at the surface during preproduction will be placed in the excavation that will need to be done prior to the construction of the underground ore storage facility. The excavation will reach the bedrock and will be equipped with a sump for seepage collection and an appropriate pumping system for water transfer to the planned water pond. No additional preparation is required as it is anticipated that sump will be a natural low point and all seepage water will be conveyed to it by gravity.

### 20.2.4 Tailings and Waste Rock Management Strategy and Site Selection Process

#### 20.2.4.1 General Tailings and Waste Rock Management Strategy

It is necessary to elaborate a general tailings and waste rock management strategy considering all existing possibilities and constraints, namely:

- The Project is set within the urban area of city of Rouyn-Noranda offering very little space for the development of storage areas. Most of the available favourable topography has already been used for tailings management by other mining companies or is impacted by old operations;

- Any TMF within the limits of the town will have either visual impact, or will affect the quality of life of neighbourhoods nearby;
- A large number of underground old historical openings are available and could be used, provided a reasonable estimate of their backfill levels is established;
- The Project mining sequence will require the use of structural cemented backfill. Thus providing a significant volume for underground paste disposal.

Considering these conditions, and the tailings production streams, several possibilities have been envisioned and studied. The following general strategies have been identified as the best available option to be pursued:

- Tailings paste backfill for mining is a very important recovery strategy and is to be extensively used in prioritizing the use of PCT as much as possible, as this stream is the most reactive one;
- Backfill of the historical openings is a necessity for several reasons:
  - Decreases surface management needs;
  - Decreases environmental footprint at surface;
  - Provides time delay for tailings surface management.

Considering this strategic orientation, work on estimating needs and tonnages have been performed. Table 20-9 summarizes the tailings distribution throughout the life of mine.

**Table 20-9: Tailings production and distribution strategy**

<b>Tailings Stream</b>	<b>PFT (million tonnes)</b>	<b>PCT (million tonnes)</b>
Paste Backfill	17.929	17.929
Backfill in historic voids	4.725	1.994
Surface TMF	28.335	9.985
Total by stream	50.989	29.908
<b>Total</b>	<b>80.897</b>	

Considering that water treatment sludge from preproduction dewatering (see Section 16.9) will also be stored in the old underground openings, the estimated remaining underground storage capacity available for tailings disposal together with the use of paste backfill will allow the storage of tailings for about two years before a surface TMF becomes necessary. Paste backfill will continue to be used throughout the entire life of the mine.

Given that all produced waste rock is expected to be acid generating and metal leaching, it is planned to be used as construction material or be placed within the TMF footprint. The waste rock should be completely buried under the PFT. Management of its exposure to the elements while deposited at surface will be required.

#### 20.2.4.2 TMF Site Selection Process

The TMF site selection study was performed following the *Environment Canada Guidelines for the Assessment of Alternatives for Mine Waste Disposal* (“EC guide”) (Environment Canada, 2011) and the general principles of Directive 019. A short summary of the alternative assessment process and results is described below.

The alternative assessment process consists in identifying and evaluating all available options for tailings and waste rock disposal. The identified alternatives are compared considering the environmental, technical and socio-economic aspects of different elements throughout the Project life cycle. The process itself consists of several steps, each leading to the narrowing of possibilities. As prescribed by the guidelines, a location map was created starting with the first step consisting in the identification of threshold criteria:

- The waste disposal area should accommodate a total of about 45 Mt of tailings in two different streams.
- The search radius for the study was established at 15 km. This radius is larger than the 10 km recommended by Directive 019, as it was felt that a project located in an urban area will encounter difficulties in identifying a suitable waste disposal area. Beyond the distance of 15 km, the cost related to the transportation of materials has been established to be unacceptably high for the proponent.
- Areas requiring project infrastructure to pass through the city of Rouyn-Noranda were excluded, as social impact was estimated to be unacceptable.
- The city of Rouyn-Noranda has been the centre of mining activities for decades. Large numbers of old mining sites, some with waste management facilities, are still present around the city. It was thus considered that if an old mining site, orphan or partially rehabilitated mine waste storage facility, was identified for the Project, its development would have to be privileged. However, sites that have undergone complete rehabilitation should not be considered as an option to avoid intervening with their closure objectives.

Figure 20-3 presents the resulting search area. A total of nine alternatives were identified within that area and one was added in an attempt to reconsider the location previously identified, by a preliminary site selection study, as the best scenario. Three sites are located immediately on top of two historical mining sites having partially rehabilitated large mine waste facilities.

All sites were submitted to the pre-screening process consisting in comparing the sites to a number of preselection criteria, namely avoiding known mineralization, protected areas and archeological sites, areas with recreational fishing and hunting activities. Part of the preselection criteria was also the requirement for the final effluent to remain at a distance in excess of 2 km from Dufault Lake. The focus of the study was also to respect current land



uses and to avoid areas with known eskers and deep water sediment deposits. The sites to be carried on to the multiple account analyses, as prescribed by the EC guide (Environment Canada, 2011), are described in the complete alternatives assessment study, part of the Environmental Impact Assessment process. The study identified the proposed TMF site as the most promising alternative for development considering thickened tailings deposition.

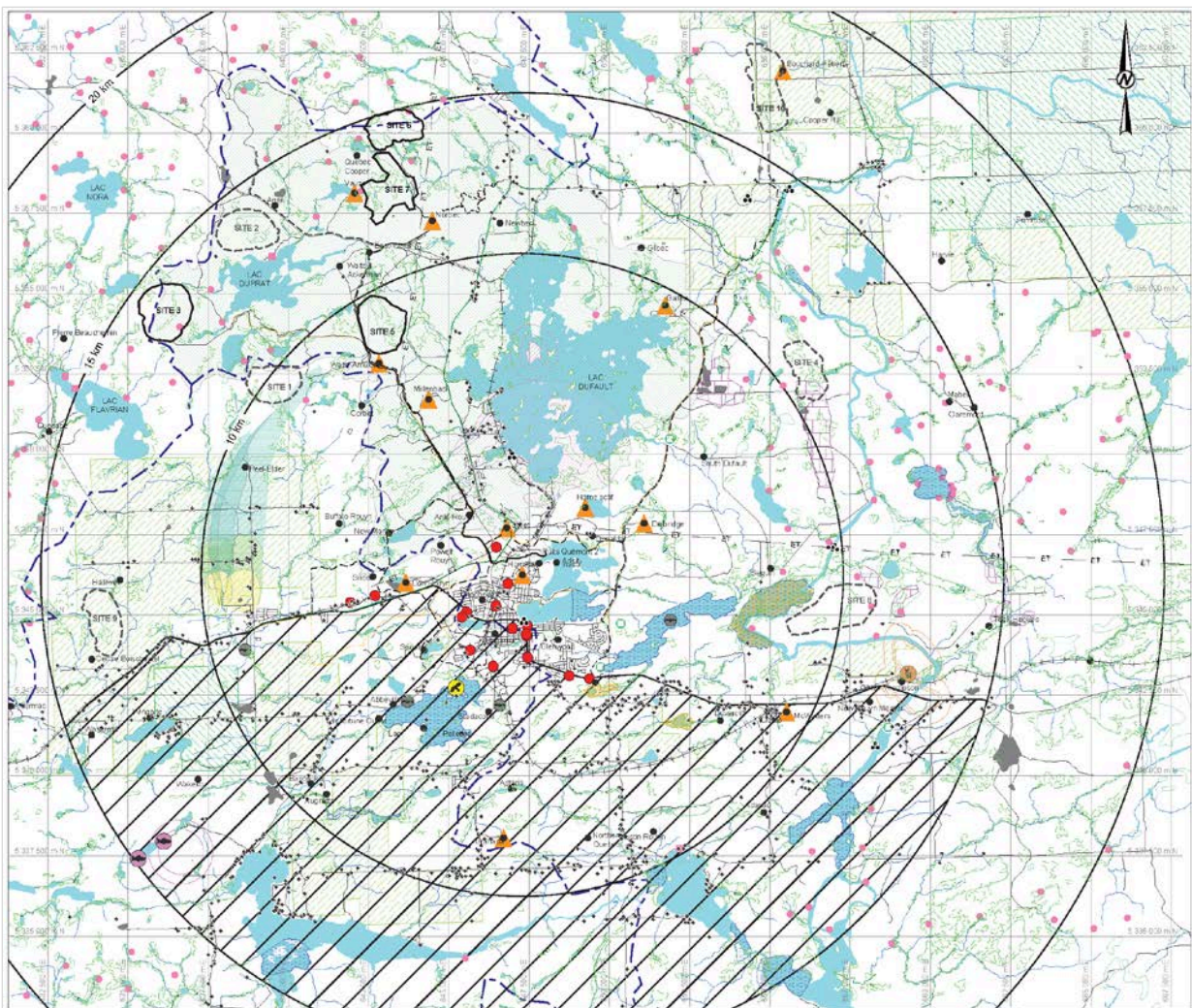

Figure 20-3: Assessment of alternatives for surface TMF

---

### 20.2.5 Underground Tailings and Sludge Disposal – Groundwater Protection

As discussed at Section 20.2.4.1, a portion of the PCT and PFT will be stored in the available underground workings of the historic Horne mine. Sludge from water treatment will also be stored in the historic Quemont and Donalda underground mine workings (see Section 16.9). Groundwater protection during production as well as following the closure of the mine were assessed accordingly.

Following the closure of the mine, it is assumed that the Horne smelter will continue to pump water from the historic Horne No.4 shaft for its process water supply. This pumping should have a similar effect on the groundwater flow regime of the upper bedrock as observed before the proposed development of the Project. Groundwater modelling results, as shown in Figure 20-4, demonstrate that this pumping would create a hydraulic containment that prevents the migration of any contaminated groundwater from the historical Horne, Quemont and Horne 5 mines toward a receptor.



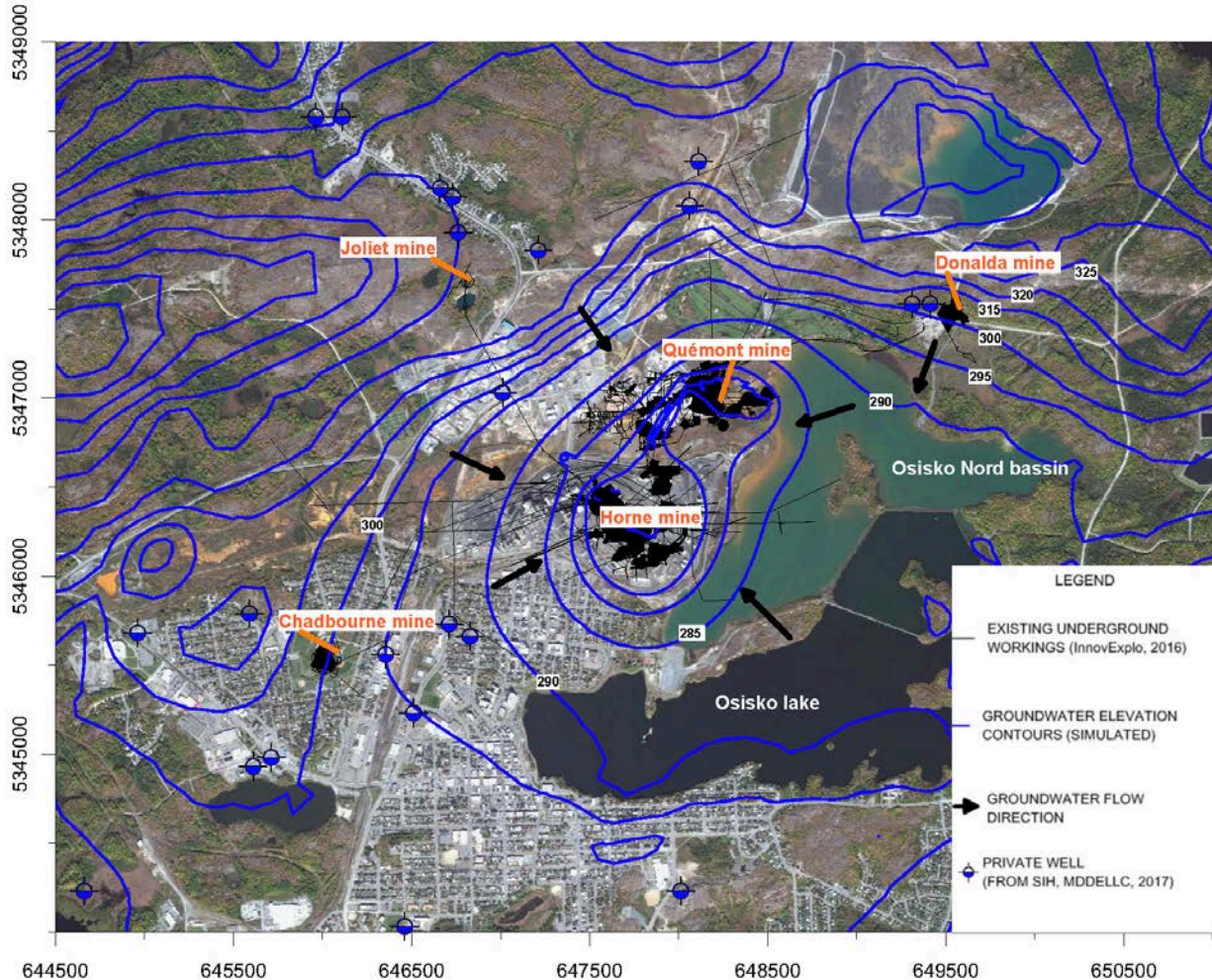

Figure 20-4: Simulated Piezometry of the Upper Bedrock – Closure Conditions

During production, bleed water from underground settling of the water treatment sludge, tailings and consolidation of mine backfill will be collected underground, pumped to the surface and used as a process makeup water (after appropriate treatment in the process plant, as required). Regarding the seepage, 3D groundwater modelling results show that the dewatering of the Horne 5 mine will create a hydraulic containment that would collect the seepage emanating from the tailings stored underground, thus preventing the migration of contaminated groundwater from Horne 5 or the historic Horne and Quémont mines towards a receptor.

Donalda will be isolated from the historic Quemont mine during preproduction (Section 16.4). Based on a desktop review and results from the 3D regional groundwater flow model, groundwater from the Donalda site would flow towards the mine workings at Quemont and Osisko North Basin. Two water wells are also present in the sector of Donalda mine based on Québec water-wells database (*Système d'Information Hydrogéologique* ("SIH"), MDDELCC, 2017) but the wells are located side gradient of the Donalda mine. Osisko North Basin is considered as the main receptor for groundwater seepage coming from the Donalda mine. Because of the possible presence of clay underneath the Osisko North Basin, the seepage, if any, coming from the Donalda mine is unlikely to cause a significant impact on this receptor.

Site-specific hydrogeological conditions are currently not available for the Donalda site. A hydrogeological study in this area will be completed in 2017 to fulfill the environmental assessment requirements.

## 20.2.6 Tailings Management Facility Site Description

The proposed TMF site is located in a hilly area, approximately 11 km north of the town of Rouyn-Noranda. The Duprat summit, at 460 m in elevation, is the highest point surrounding the site. The site sits on two watersheds commonly named Duprat and Vauze. These watersheds are tributaries to Dufault Lake via the Duprat River (Duprat watershed) and via the Vauze Creek (Vauze watershed). The water elevation of Dufault Lake is 295 m.

This section contains the summary description of the regional geology of the proposed TMF site, followed by short descriptions of the historical activities that took place at the site, its current configuration and the general geotechnical and hydrogeological conditions.

### 20.2.6.1 Regional Geology

According to the regional surface characterization made by Géoconseil in 1997 (Golder, 1998), the Norbec Mine is located in the Blake River Group in the Sub-Province of Abitibi. The mapped region is part of the Noranda subgroup consisting of a sequence mostly composed of calc-alkaline affinity units, with an important tholeiitic component (35%) and a minor alkaline quantity. In the sub-alkaline affinity units, the average abundance of the mafic units (basalt, andesite) is 50%, while the dacitic and rhyolitic units share the remaining 50% equally. These lavas come from several eruptive centres.

The major faults in the area are the Vauze Creek Fault ("VCF") and the Hunter Creek Fault ("HCF"), both oriented east-northeast and of subvertical dips. The Alembert shear dividing the region in different domains is also a dominant feature. Moreover, two inverse faults to the stratigraphy were recorded on the ground: the Norbec fault and the settling pond fault. They are located between the VCF and the HCF, with a north-northwest orientation and a dip between 35° and 40°.

Major breaks are subparallel to stratification, such as the Norbec inverse fault or, they are clearly transverse, such as the VCF. Moreover, a major tangential fault is present to the pluton of Dufault Lake.

The structural analysis shows two major networks, the first one is oriented at  $305^{\circ} \pm 15^{\circ}$  with a dip varying between  $70^{\circ}$  and  $85^{\circ}$ , and the second orientated at  $75^{\circ} \pm 10^{\circ}$  with a dip of  $70^{\circ}$ . The majority of the fractures, with or without displacement, follow the two major orientations mentioned above. Otherwise, a network of conjugate structures, also well developed in the region, is oriented at about  $30^{\circ}$  with dips from  $20^{\circ}$  to  $-20^{\circ}$ .

The existing tailing and water ponds area is the intersection point of major faults including the VCF, the Norbec inverse fault, the settling pond fault and a major fault in direction  $30^{\circ}$ .

#### 20.2.6.2 Historical Development

Mining operations at the Norbec site started in 1964 under the name of Norbec mine and was owned by Falconbridge Copper Corporation, "Division Lac Dufault". The operation consisted of an underground mine and a copper and zinc process facility. The capacity of the process facility varied between 1,200 tpd and 1,400 tpd. The Norbec mine underground mine operation ceased in 1976, but the process facility continued to be used to process ore from Millenbach (1971-1980), Corbet (1979-1986), Ansil (1989-1993) and Donalda (1995) Mines. The process facility closed in 1995 and no further mining activities has been recorded at the site since then.

Since the beginning of the operations, all tailings from ore processed at the site were confined in the Norbec Mine tailings storage facilities. In close to 30 years of activity, about 10 Mt of tailings were generated and stored in two different surface storage facilities, namely Tailings Pond #1 and Tailings Pond #2. The tailings were deposited as slurry within these storage facilities and were confined by low permeability dikes. The water was transferred to OX-1 and depending on its quality, was then transferred to OX-2 before being released into the environment via the Vauze Creek.

A series of rehabilitation works, including the demolition of all buildings, the excavation of mine access roads and partial reinforcement of some dikes, was initiated at the end of the operations, in 1995, under the previous ownership of Inmet Mining Corporation. The current owner of Norbec mine is First Quantum Minerals.

#### 20.2.6.3 Current Site Conditions

The current site configuration consists of the two former tailings ponds and a series of water ponds (Duprat Basin, OX-1, OX-2, Red Water Pond, Sedimentation and Polishing Ponds). Two water treatment plants are currently present and operating, the High Density Sludge ("HDS") and the conventional lime water treatment plants ("LTP"). A plan view of the site is



shown in Figure 20-5. A short description of the former tailings ponds and water ponds is presented below.



Figure 20-5: Plan View of Norbec Mine Site

- The Tailings Pond #1 is the oldest tailings storage area at the site with a total footprint of about 6.5 ha standing at a maximum elevation of 360 m. Tailings Pond #1 surface elevation is the higher of the two tailings storage areas, located approximately 20 m above Tailings Pond #2 surface elevation. The total thickness of tailings placed in Tailings Pond #1 is estimated to be around 15 to 25 m. Tailings stored in this area are potentially acid generating and are confined by three dikes namely, Dike West, North and South. The Tailings Pond #1 surface has been partially rehabilitated with the placement of about 150 mm to 900 mm of clayey soil on top of the tailings and subsequent seeding. Vegetation cover currently consists of some scarce low pine trees and grass. The North, West and South Dikes downstream slopes have also been partially reinforced. Precipitation falling directly on Tailings Pond #1 surface run off either towards Tailings Pond #2 or the environment.
- The Tailings Pond #2 is located directly downstream of Tailings Pond #1, to the north. Its surface stands at an approximate elevation of 340 m and its total footprint is about 17 ha. The area stands at the toe of Tailings Pond #1 North Dike and is confined to the north by the Main Dike. Precipitations falling on Tailings Pond #2 surface run off either towards OX-1 pond or the Red Water Pond, or are temporarily retained at its surface. Tailings placed in this area are potentially acid generating. Also, all acid-generating materials, such as waste rock, excavated from the access road and platforms of the mine were also placed within Tailings Pond #2. Tailings Pond #2 has not been rehabilitated, with the exception of some North Dike reinforcements and arrangements at the surface for water collection.
- The Red Water Pond collects run-off and seepage from the eastern portion of the Main Dike. Seepage from Tailings Pond #2 is acidic and is loaded with heavy metals. Water from this basin is normally transferred to the OX-1. The pond is limited by Tailings Pond #2, and water is retained by Dikes X, H and J, which are all internal dikes.
- The OX-1 is located downstream of Tailings Pond #2 and is confined by Dikes A, B, BC, C and D. It collects all the acidic water of the site. The water then goes through the HDS plant before being transferred to the polishing pond.
- The OX-2 Pond water level is controlled by Dike E. Water elevation of the pond is currently maintained at 324.5 m. The OX-2 has a large watershed as it uses the bed of the upper portion of Vauze creek, while collecting water from the Vauze Lake via its outlet. The OX-2 was used as a secondary oxidation pond for the mine water at the time of the Norbec Mine operation. Today, OX-2 water quality and level are still controlled. If required, the water is treated by the LTP before being transferred to the polishing pond.
- The polishing pond stores water coming from the HDS plant and the LTP before being transferred to the environment via the final effluent point. The pond is separated from the polishing pond by Dike F and from the Red Water Pond by Dike H to the southeast. The polishing pond is confined to the west by Dike G, which is the final effluent point.



- The Duprat Water Pond collects runoff water from areas located within the Duprat watershed of the property. Direct transfer of this runoff to the series of water ponds to the north is not possible without the pumping system. The Duprat Water Pond is divided into two cells commonly named Duprat East and Duprat West. The water collected in Duprat East is pumped out to the environment and sampled twice a month as per CoA. The water from Duprat West is pumped to the OX-1, located to the north.

The last known rehabilitation works were carried out at the Norbec Mine site was in the very early 2000s. Today, the only infrastructure remaining on site is the pumping station of the Duprat Water Pond, the electric substation, the two water treatment plants and the final effluent pumping station.

#### 20.2.6.4 Geotechnical Conditions

The area is located within the limits of the former glacial lake Barlow-Ojibway, where topographical lows and surface depressions are filled with fine glacio-lacustrine sediments, and hills are covered by coarser sediments and top soil. As per the surface geology map of the region, the area is characterized by outcrops of Precambrian metamorphic rock, till (discontinuous, 1 m thick), ice contact sediments (from 5 m to 20 m thick), peat (overlying poorly drained fine sediments, 0.5 m to 5 m thick) and modern alluvial deposits (sand and gravel, silty sand, clayey silt, 1 m to 5 m thick).

Limited number of geotechnical boreholes and test pits were completed at the site, mainly in connection with the late 90s and early 2000s site rehabilitation works. The limited available geotechnical information thus generally shows that the stratigraphy consists of a layer of till sitting on bedrock. Layers of clay up to 7.5 m thick and with variable consistency are present within the topographic lows. Figure 20-6 shows the general geotechnical map of the site.

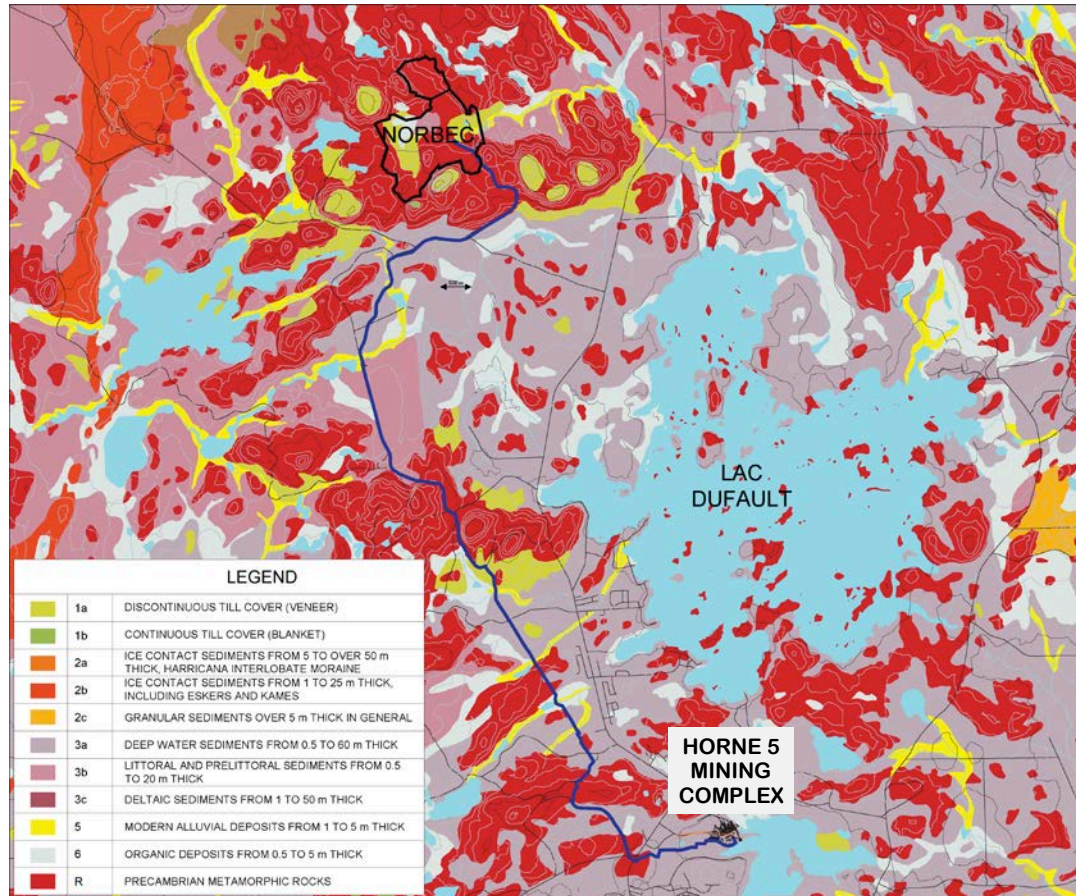

Figure 20-6: General geotechnical conditions for Norbec mine site (adapted from Veillette, 2003)

### 20.2.6.5 Hydrogeological Conditions

The hydrogeological conditions at the Norbec Mine site were defined based on a desktop review.

According to surface geology map (Veillette, 2003 – see Figure 20-7), Vauze creek flows on a narrow strip of alluvial deposits that overlay littoral sediments (sand, silty-sand, boulders and gravel). On the south, west and north sides of the Norbec Mine site, the surface geology consists mainly of outcropping bedrock (Veillette, 2003). Data from previous investigation (Golder 1995 and 1998) have shown that the type of soil and thickness is variable across the site. The grain-size distribution of overburden consists generally of silts, with the presence of sand and clay. When present, overburden thickness varies between 10 m to 25 m. Available hydraulic conductivity values were  $1 \times 10^{-7}$  m/s for clay and  $6 \times 10^{-6}$  m/s for the silty sand and existing tailings.

According to the available topographic maps, groundwater flow within the proposed TMF from the Tailings Pond #1 to OX-1 then towards Vauze creek, located to the East of OX-1. In the Duprat area, groundwater flow direction would be southward, towards the Duprat Water Pond.

Based on the search in the Québec water-wells database, wells seem to be located within a distance of 1 km southeast of the Norbec Mine site, close to the Duprat area water ponds (MDDELCC, 2017). However, these wells are not in the same watershed as the proposed TMF.

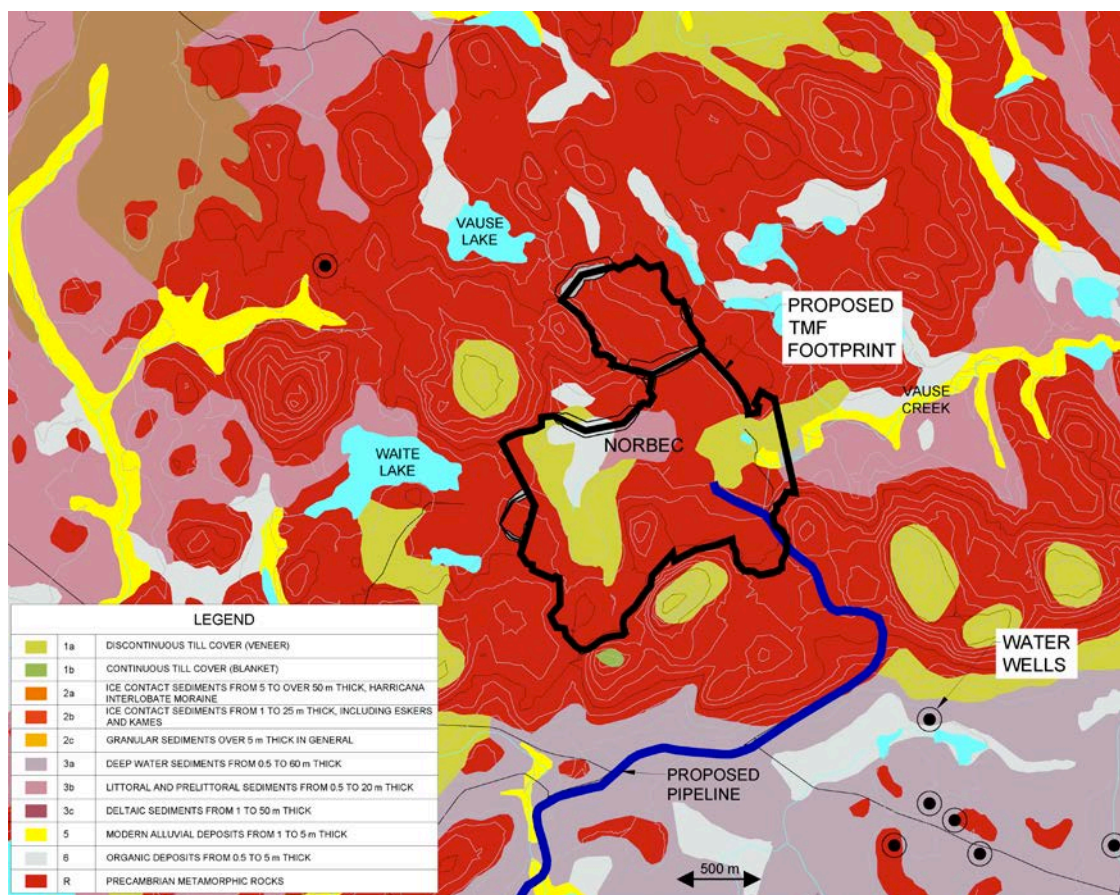

Figure 20-7: Surficial Geology of the Norbec Mine Site (adapted from Veillette, 2003)



## 20.2.7 Tailings Management Facility

### 20.2.7.1 Basic Design Parameters

The following was established to be the basic design criteria for the Horne 5 Project TMF site:

- PCT and PFT are to be managed in two separate areas allowing the tailings streams to be delivered separately at different rates. Bleed water from the two streams, however, can be mixed and either pumped back to the process plant for recycling or pumped to a water treatment plant.
- PFT will be delivered at 62-63% solids content (per weight), PCT will be delivered at 47% solids content (per weight).
- Total tonnages to be stored in the surface TMF site have been established as per Table 20-9. For design purposes, it was assumed that tailings from both streams will consolidate to about a 0.85 void ratio. Table 20-10 presents the volume calculations for both PFT and PCT together with the Specific Gravity testing results.

**Table 20-10: TMF Site – PFT and PCT specific gravity testing results and volume calculations**

	PFT	PCT
Void ratio (assumed)	0.85	0.85
Specific Gravity (Golder)	2.76	4.44
Specific Gravity (URSTM)	2.79	4.37
Specific Gravity (SGS)	2.79	4.63
Calculated Dry Density	1.51 tonnes/m <sup>3</sup>	2.36 tonnes/m <sup>3</sup>
Total Production Per Stream	<b>28.335 million tonnes</b>	<b>9.985 million tonnes</b>
Total Volume Per Stream	18.765 Million m <sup>3</sup>	4.230 Million m <sup>3</sup>

Specific gravity for PCT and PFT was tested by Golder using vacuum de-aired water, by SGS using nitrogen-purged “Micromeritics” multivolume pycnometer, model 1305, and by URSTM using a Helium Pycnometer. Dry densities have been calculated using Specific Gravity established by Golder test results.

### 20.2.7.2 Tailings Geotechnical Properties

One sample of PCT and PFT, made available from the metallurgical testing, was tested for grain size distribution. The obtained grain size distribution curves are presented in Figure 20-8a.

The particle size distributions for PFT and PCT obtained by Golder were determined using a Finch laser particle analyzer, SGS used Malvern laser particle analyzer and URSTM used Microtrac laser particle analyser, all according to ASTM D4464. Results show some variations, but from a geotechnical point of view, these variations are small and no variations in behaviour are expected.

One direct shear test was performed in drained conditions on the PFT tailings by URSTM. The test was conducted at a water content of approximately 27% (initial void ratio of 0.777) and at confining pressures of 75 kPa, 150 kPa and 400 kPa. The results show an effective friction angle of 26 degrees and an effective cohesion of 27.5 kPa.

One standard Proctor test was also performed on the PFT by URSTM. The results show a maximum dry density of 1.69 g/cm<sup>3</sup> at a water content of 18%. Figure 20-8b shows the compaction curve results.

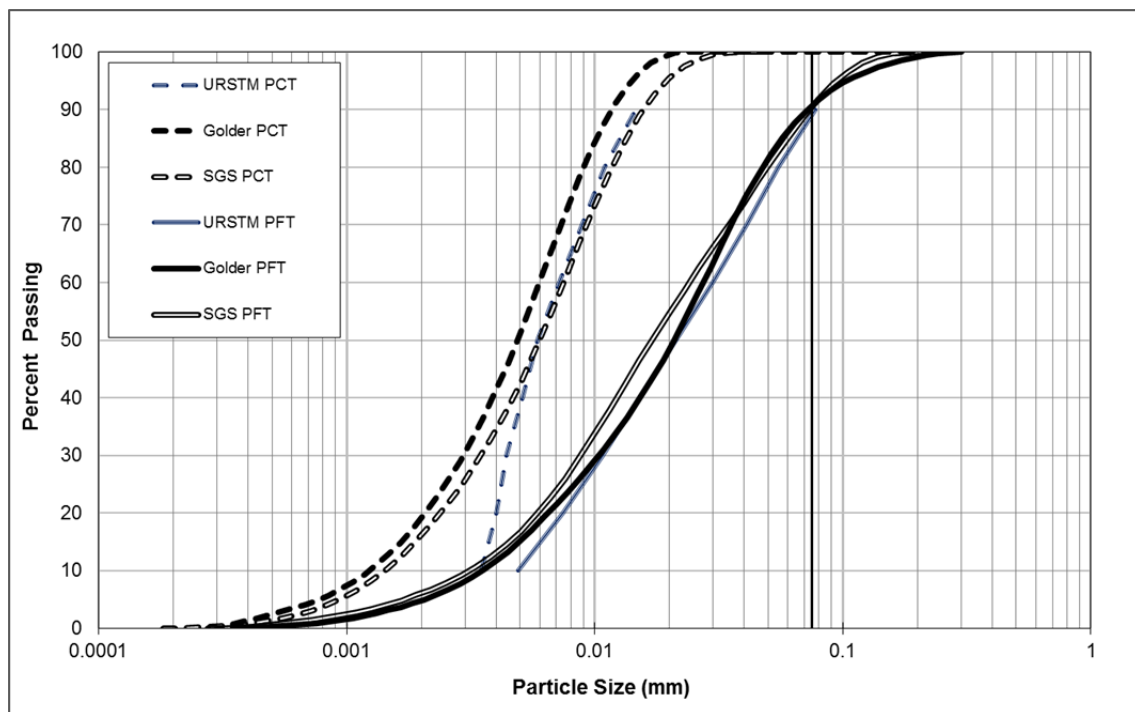

Figure 20-8a: PCT and PFT particle size distribution curves

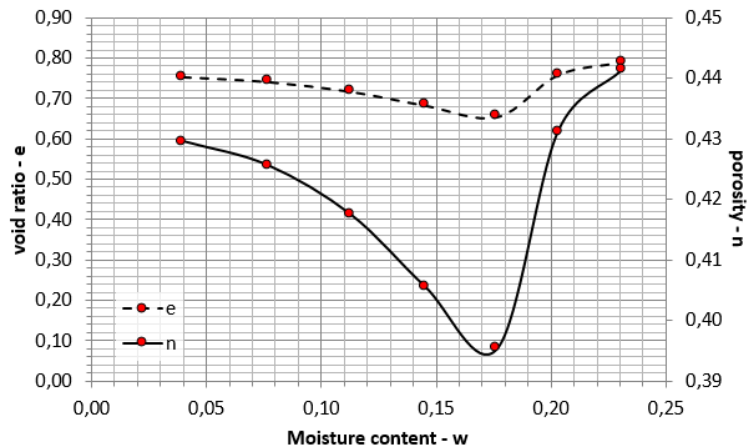
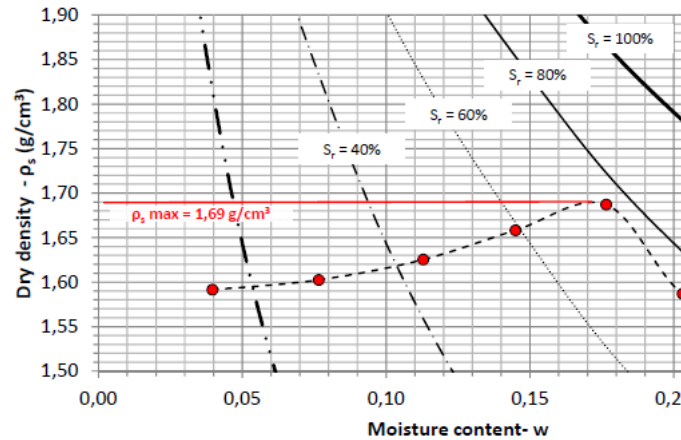

Figure 20-8b: PFT standard Proctor testing results

### 20.2.7.3 Waste Rock Geotechnical Properties

A total of approximately 1.6Mt of waste rock will be hoisted to surface during preproduction. The waste rock grain size probable distribution has not been defined yet. The percentage of fines is expected to be around 15% with an overall fine grain-sized angular rock particle.

The friction angle for the waste rock, if used as construction material, remains to be defined at this stage of the Project. Based on our experience with similar projects, it can be reasonably assumed that the friction angle would vary between 34 and 37 degrees. It should also be mentioned that the weathering of waste rock disposed of at surface can have an impact on the friction angle in the long term. With an assumed specific gravity of waste rock at 2.75 and a swell factor of 1.3, a dry density of 2.1 t/m<sup>3</sup> can be expected. Using this dry density, Table 20-11 presents the conversion of tonnages to volumes for surface disposal.

**Table 20-11: Waste rock volume calculation for surface disposal**

	2019	2020	2021
Quantity (metric tonnes)	489,142	920,889	221,361
Corresponding volume (m <sup>3</sup> )	232,925	438,519	105,410

#### 20.2.7.4 Surface TMF General Description

##### General

Consistent with the general design parameters listed in Section 20.2.7.1, the design outlined in this chapter for the FS of the Project is not the final design of the facility. The final design of the facility will include changes based on the gathering of geotechnical and hydrogeological information for the foundations, the application of the observational method based on periodic reviews by the designer and Falco, as well as third party reviewers, and the refinements based on testing of the tailings streams and all construction materials. In addition, input from borrow sources' search, QA/QC program to be carried out during construction and hydrogeological modelling may result in design modifications.

Staged construction and operation of the TMF is proposed. It is anticipated that activities, such as water storage, water treatment, and waste rock disposal would already be ongoing at the site, prior to the start of the TMF construction. The TMF will consist in two separate cells namely, PCT Cell and PFT Cell, and two water ponds, the internal pond and the polishing pond (see Figure 20-9). The PFT Cell will be expanded by overtaking the polishing pond in the last few years of mine life. A second polishing pond will then be required. It is anticipated that the initial construction would start with a configuration allowing each stream to be stored separately and to confine the internal pond and the polishing ponds. Preparation works would consist in deforestation, construction of access road, topsoil stripping and leveling.



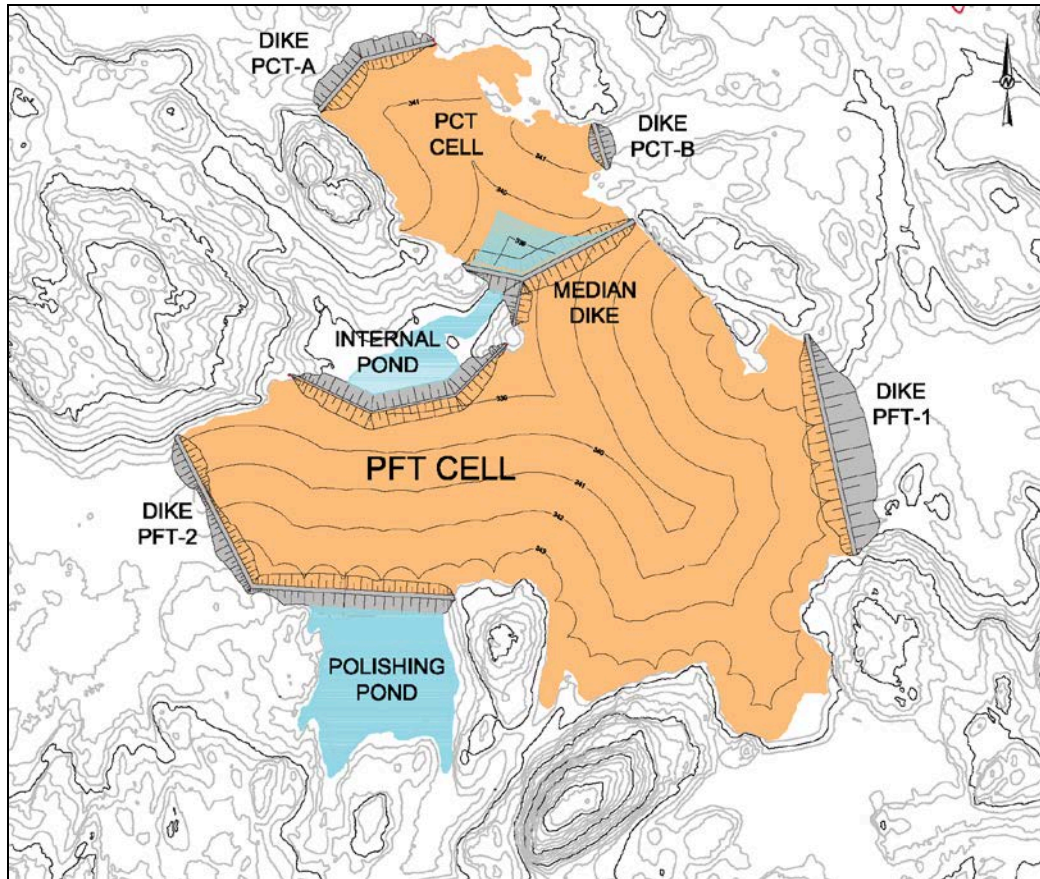

Figure 20-9: Plan view of the Horne5 TMF at surface  
(Year 2033 at the end of Stage 4)

It is proposed to line the entire PCT Cell as PCT tailings are expected to be highly reactive and to start acidification relatively rapidly at surface. The PFT Cell is not expected to need a liner on its entire footprint. Measures will be taken to improve the foundation conditions, if exposed fractured bedrock surfaces or high permeability areas are encountered during geotechnical and geophysical investigations.

It is proposed that the Internal Dike be an entirely permeable structure to collect bleed water from the PFT Cell, pumped water from the PCT Cell and contact surface run-off. The intent is to maintain the internal pond water level low, and thus lower the phreatic surface in the PFT Cell. Considering that the PFT is expected to form a low permeability mass over time, it is also planned to put two underdrains in place, conditional on modelling results. These underdrains could use existing features at the site such as sand and gravel abutments of existing confinement dikes.

It is recognized that lining the PCT Cell would slow down drainage and settlement of the PCT. It is proposed to put in place a pumping system in the Median Dike that can be run during operation and at closure of the cell in order to collect bleed water. This system would be part of the construction sequence and would be raised simultaneously with the increase in the cell height.

### TMF Construction Sequence

The surface TMF site will be required to be operational at the second quarter of 2023. Starting in 2022, it is proposed to operate it in five stages, each stage lasting approximately two to four operating years. Table 20-12 presents the crest elevations and the approximate duration for each stage.

Table 20-12: TMF staged construction – crest elevations

Structure	Stage 1 (Q2 2023- Q2 2025)	Stage 2 (Q3 2025- Q2 2027)	Stage 3 (Q3 2027- Q2 2029)	Stage 4 (Q3 2029- 2033)	Stage 5 (2033-2035)
	(m)	(m)	(m)	(m)	(m)
PCT Cell: PCT-A and PCT-B Dikes	330.5	335.0	337.0	342.0	347.0
PFT-1	332.25	335.25	338.5	344.0	-
PFT-2	335.25	335.25	338.5	344.0	-
Median Dike	331.0	334.0	338.5	342.0	346.0
Internal Dike	331.0	334.0	338.5	342.0	-
Polishing Pond Cell (PFT-3)	-	-	-	-	343.0

### TMF Deposition Planning and Overall Operation Management

The deposition plan was prepared using Muck 3D, a program developed by MineBridge Software. This software simulates the tailings deposition from different discharge points simultaneously and allows the scheduling of the dike construction. The software is used to generate the fillings scheme, the capacity curves and the construction quantities.

For the purpose of planning and design of the TMF, typical deposition slopes were assumed based on experience with other projects, as follows:

- PCT: 0.5% above water, 1% below water;
- PFT: 1% above water, 2% below water.

Deposition of tailings is planned to take place simultaneously in the two cells according to the following general guidelines. Deposition is expected to use multiple discharge points system, such as spigots, to decrease energy flow and to build smooth high tailings beaches against all confining structures:

- PCT Cell: deposition is expected to take place from PCT-A Dike, and later from both PCT-A and PCT-B Dikes. This will push water away from the two main confining dikes towards the Median Dike. Supernatant water from the PCT would be transferred by pumping while the Median Dike internal pumping system would continue to collect and pump bleed water from the PCT Cell.
- PFT Cell: deposition of PFT tailings takes advantage of several topographical high points. At the first stage of the development, it is anticipated that tailings will be discharged from dike PFT-1 thus pushing water away from the structure. At subsequent development stages, tailings will be deposited both from the topographical high points and the two confining dikes PFT-1 and PFT-2.
- Final stage: at the end of the operation it is planned to continue deposition in the PFT Cell and later move PFT deposition to the polishing pond until the pond is entirely filled. The necessity of moving the deposition to the polishing pond will be confirmed and adjustments will be made if capacity, based on actual performance, can be achieved within the PFT Cell.

Table 20-13 provides a summary of the total tailings tonnage and corresponding volume accommodated by each stage of the TMF development.

**Table 20-13: Tailings and water storage volumes – deposition plan**

Stage	PCT		PFT	
	Tonnage (Mt)	Volume (Mm <sup>3</sup> )	Tonnage (Mt)	Volume (Mm <sup>3</sup> )
1: (Q2 2023 to Q2 2025)	1.69	0.72	5.05	3.34
2: (Q3 2025 to Q2 2027)	1.63	0.69	4.62	3.06
3: (Q3 2027 to Q2 2029)	1.64	0.69	4.58	3.03
4: (Q3 2029 to 2033)	3.75	1.59	10.51	6.96
5: (2034 to 2035)	1.27	0.54	3.57	2.36
<b>Cumulative</b>	<b>9.98</b>	<b>4.23</b>	<b>28.33</b>	<b>18.76</b>

Figure 20-10 to Figure 20-14 illustrate the TMF staged development (plan views).



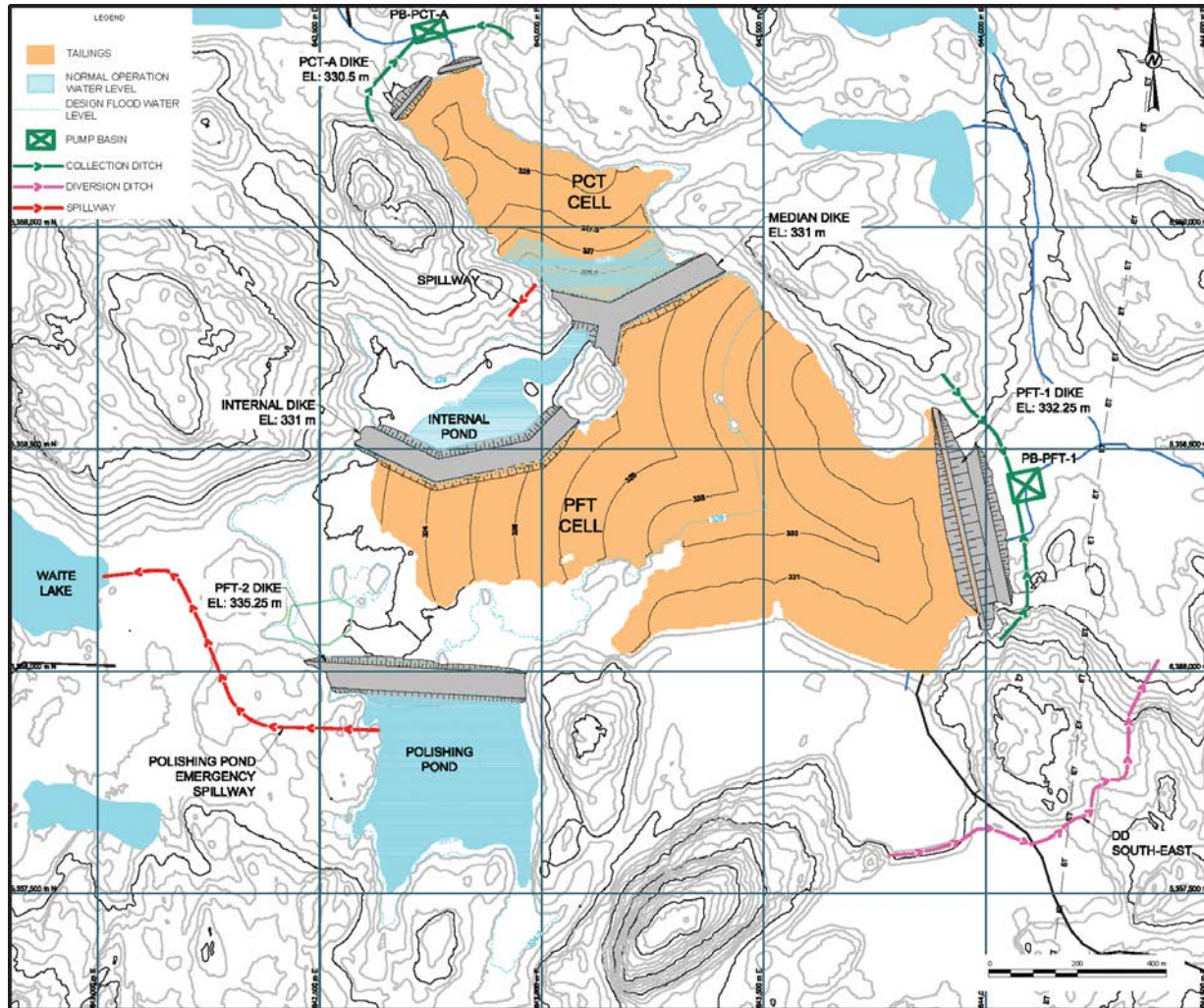

Figure 20-10: Surface TMF development sequence – Stage 1

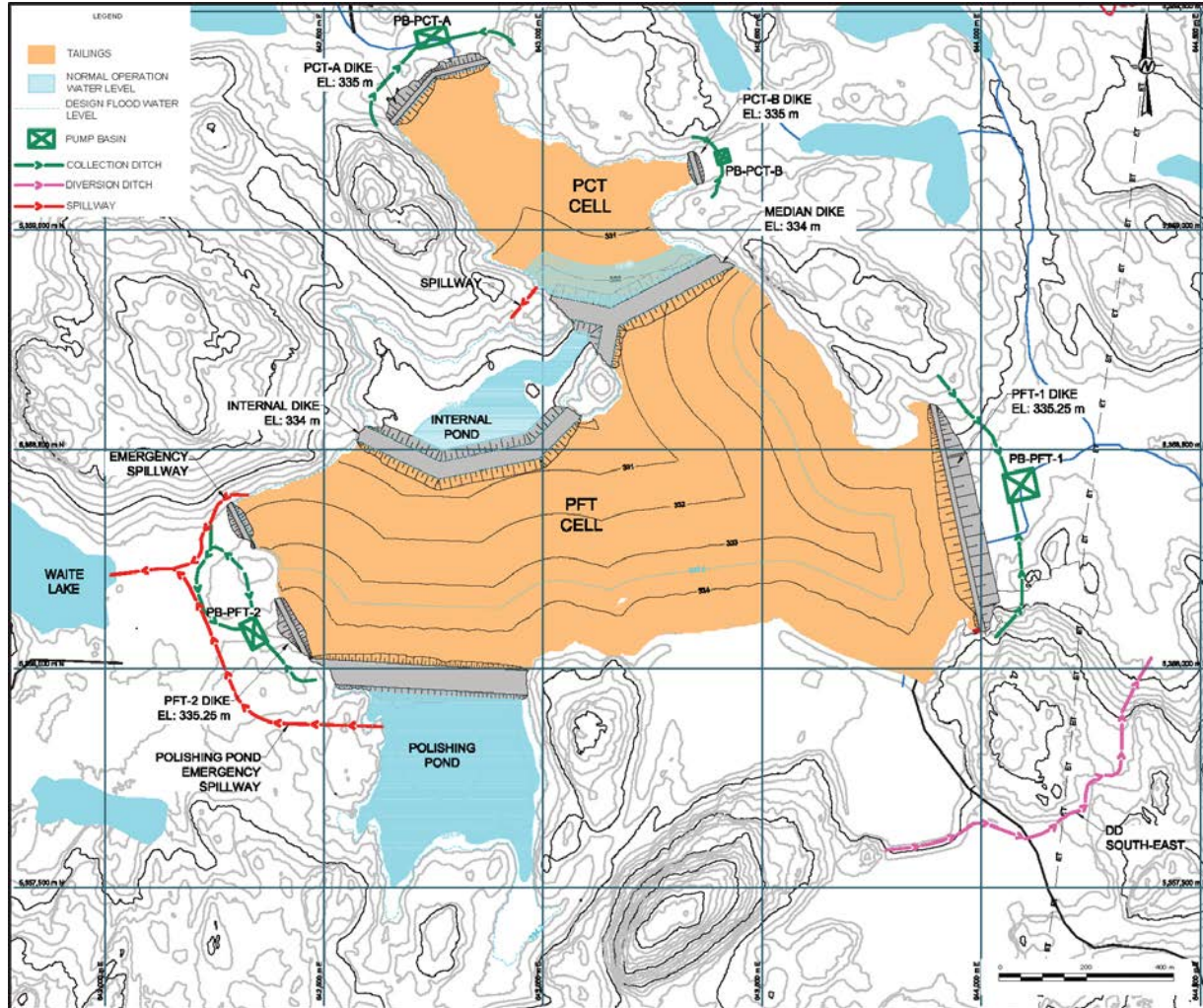

Figure 20-11: Surface TMF development sequence – Stage 2



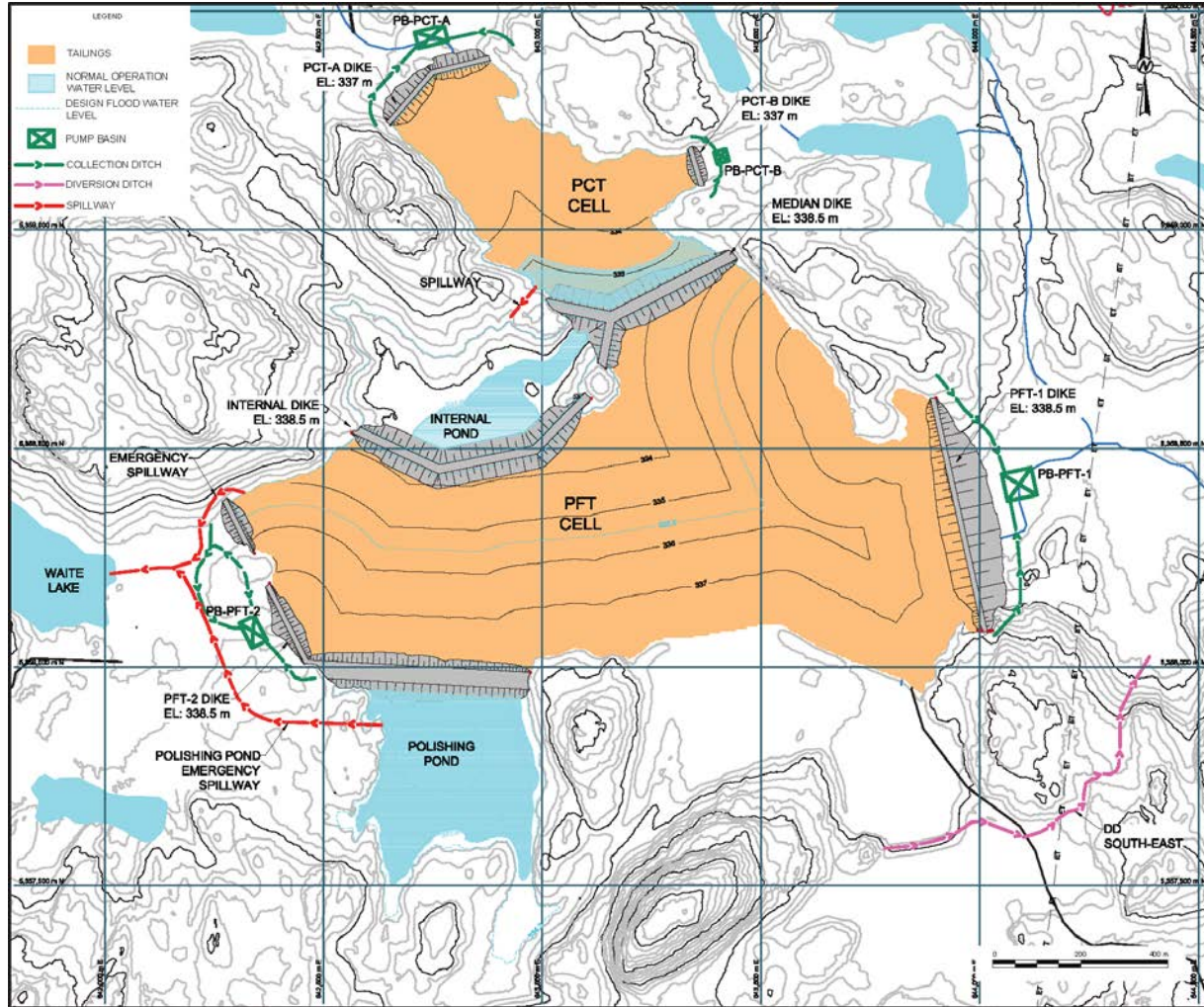

Figure 20-12: Surface TMF development sequence – Stage 3

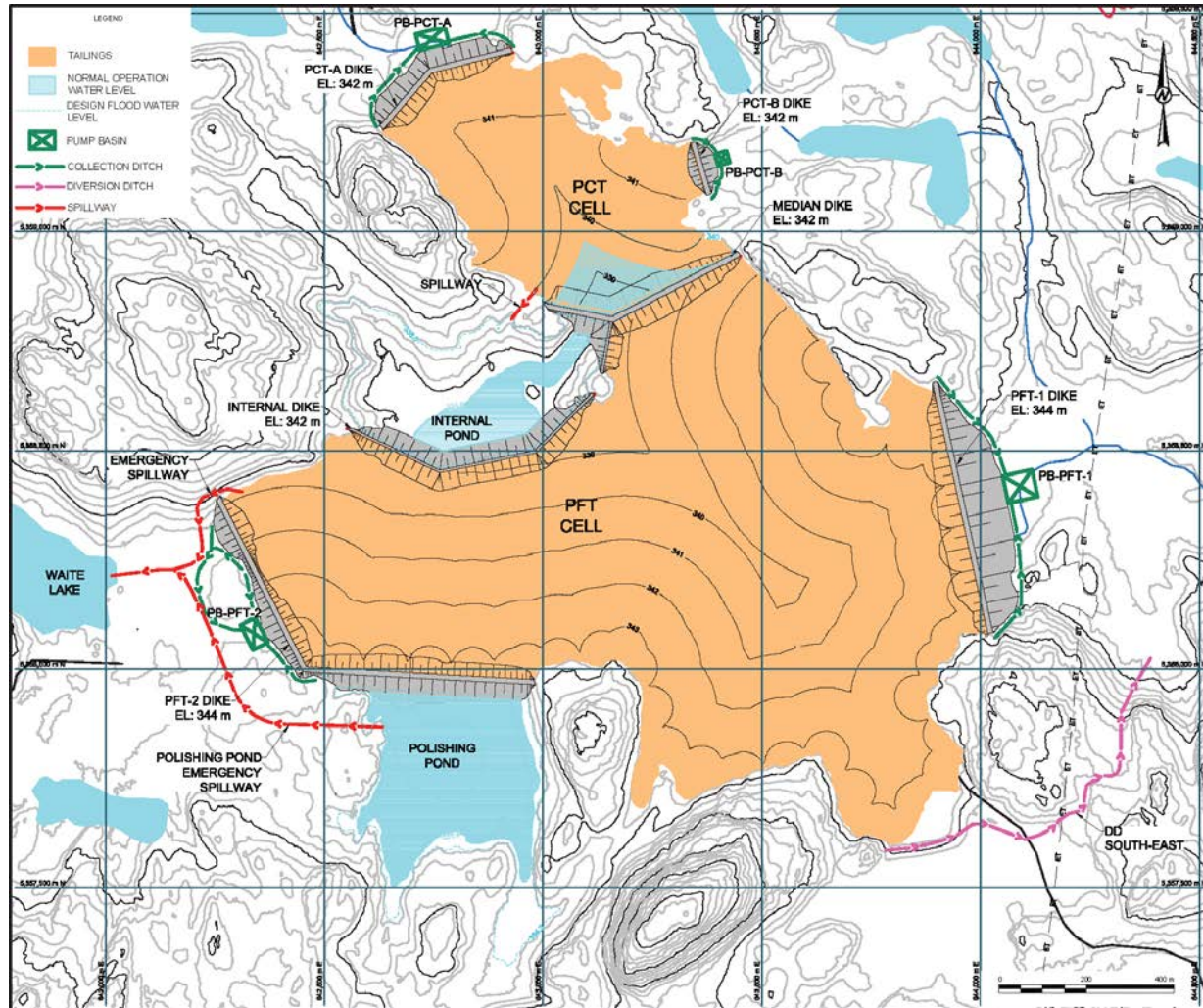

Figure 20-13: Surface TMF development sequence – Stage 4



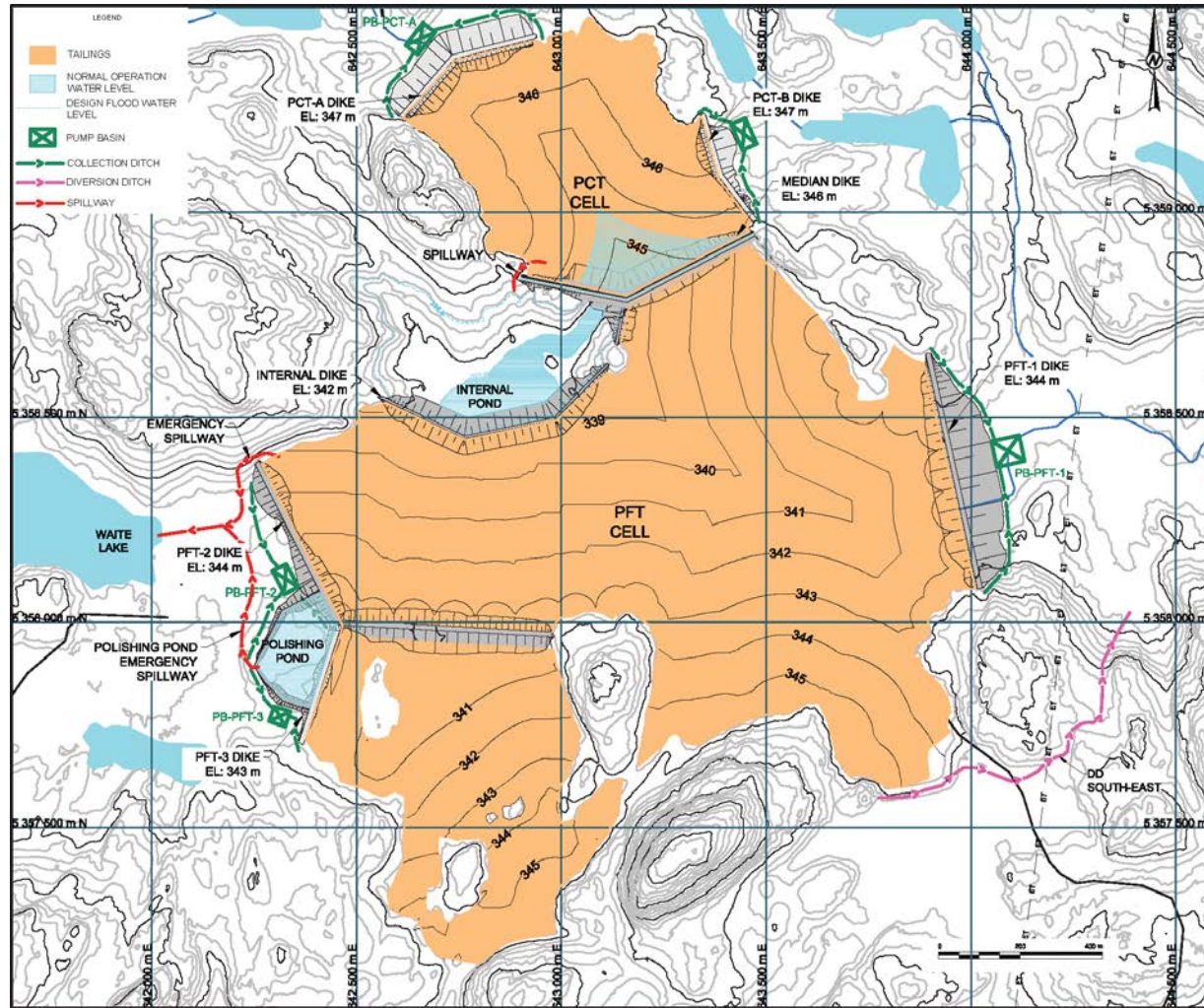

Figure 20-14: Surface TMF development sequence – Stage 5

### 20.2.7.5 Surface TMF Classification

The Canadian Dam Association (“CDA”) provides alignment and recommendations for mining dams in its technical bulletin published in 2014 (CDA, 2014). The CDA guidelines rank mining dams according to the consequences of a hypothetical dam failure. Potential loss of life, economic losses, environmental losses, and cultural losses are considered in the classification. Dams or dikes are classified according to the failure risk from low to extreme with an incidence on design criteria for each of these categories. A detailed analysis of failure consequences remains to be conducted for the TMF in accordance with the CDA guidelines including:

- Establishing failure mechanisms for each retention structure;
- Performing dike breach analysis including the modelling of the breach flood wave propagation and attenuation;
- Preparing a map identifying flood extent with respect to encountered infrastructure;
- Verifying dam classification based on the detailed consequences of failure analyses and adjusting the design criteria, if necessary;
- Assessing the impact of potential failure to water quality in lakes or streams, if required;
- At this stage, a preliminary consequence of failure analysis has been carried out for the TMF. Based on Table 3-1 of the 2014 CDA Bulletin (CDA 2014), the assessment focused on the PFT-1 dike which will very likely lead to the highest consequences of failure. Potential failure mechanisms for the PFT-1 dike were identified to be internal erosion or foundation failure, and tailings were then assumed to liquefy and flow through the breach. Water overtopping the PFT-1 dike is estimated to be an unlikely event, but could still be a plausible failure mode for other retaining structures at the TMF. The wave caused by the hypothetical loss of confinement would propagate east, would cross road 101 and D’Alembert municipality, located about 3 km east of the TMF, and would then turn south towards Lake Dufault, where the wave attenuation would happen. The consequences of failure are thus estimated to be:
  - Population at risk: “*Permanent*”, as the flood wave would likely impact permanent residences around road 101 crossing and around D’Alembert municipality;
  - Loss of life: “*100 or fewer*”. Residences, commercial buildings, public roads and a school, all located around road 101 crossing and in D’Alembert municipality, might be impacted. It was assumed that mitigation measures, including potential peak flow attenuation structures, warning systems, and others, will be implemented and will limit the loss of life consequences. For the current evaluation however this incremental loss level is estimated to be reasonable;

- Environmental and cultural values: “*Significant loss or deterioration of important fish or wildlife habitat. Restoration or compensation in kind highly possible*”. The PFT-1 dike breach would necessarily impact the areas located downstream of the TMF. It is estimated that significant loss or deterioration of fish or wildlife habitat would be experienced due to the nature of the tailings and TMF proximity to Dufault Lake. There is a risk that the loss could be permanent. However, it is also assumed that rehabilitation or compensation is highly possible;
- Infrastructure and economics losses: “*High economic losses affecting infrastructure, public transportation, and commercial facilities*”. PFT-1 dike breach would potentially incur local damages to a 120 kV electric line located approximately 500 m of the dike, the 101 road and buildings in D’Alembert. Rouyn-Noranda’s potable water intake located in Lake Dufault could be affected if water quality in the Lake is affected by the spill. However, given the location of the intake (7 km away from the estimated point of entry) it is considered that mitigation measures are possible and will be put in place. Further analyses will be required to establish if indeed affecting the water quality is a potential risk.

Based on the preliminary assessment of the consequences of failure, dike PFT-1, and consequently all TMF retaining structures, were assigned the dam classification of “Very High”. Detailed analysis will be carried out at the detailed design stage to confirm this assessment. Meanwhile, this classification and the associated CDA recommendations were considered together with Directive 019 recommended criteria when selecting flood and earthquake hazard levels for the TMF design. Design earthquake considerations are discussed in the next paragraphs. Flood hazard target levels are discussed in Section 20.2.8 on water management along with criteria recommended by Directive 019.

#### 20.2.7.6 Dike Design Criteria and Typical Cross-Sections

##### Dike Design Criteria

Dike design criteria have been established considering two guidelines applicable to the TMF development, Directive 019 (March 2012) and CDA (2014). As discussed in Section 20.2.7.5, only CDA proposes a classification methodology for mining dams; however, Directive 019 recognizes this methodology and recommends its use.

▪ **Design Earthquake**

CDA (2014) states that dikes shall be designed based on an Earthquake Design Ground Motion determined according to the consequence of failure of the dike. As mentioned, for “Very High” consequence of structure failure, the suggested design earthquake should target an annual exceedance probability halfway between 1 in 2,475 years and 1 in 10,000 years. In addition, Directive 019 recommends using design earthquakes with an annual exceedance probability no lower than 1 in 2,475 years. Thus, the exceedance probability of halfway between 1 in 2,475 years and 1 in 10,000 years was established as the design criteria for the TMF.

The 2010 National Building Code of Canada (“NBCC”, 2010) was consulted and, at the location of the TMF site, the peak ground acceleration (“PGA”) is 0.065 g for the probability of exceedance of 2% in 50 years (return period of 1 / 2,475 years). The code does not provide PGA for lower probability exceedances as these are normally required for special facilities. Earthquakes Canada provides some guidance on a methodology based on extrapolation of the values of PGA for 1 in 475 and 1 in 2,745 years. Using this methodology, a screening value for the PGA was estimated for the design criteria.

▪ **Slope Stability Factors of Safety (“FoS”)**

For the Feasibility Study, the following minimum FoS have been established considering the applicable guidelines (Table 20-14 and Table 20-15).

**Table 20-14: Minimum FoS for slope stability in construction, operation, and transition phases – static assessment**

Loading Conditions	Minimum FoS	Slope	Guideline
During or at the end of construction	> 1.3 depending on risk assessment during construction	Typically downstream	CDA, 2014
	1.3 to 1.5	Unspecified	Directive 019, 2012
Long Term (steady state seepage, normal reservoir level)	1.5	Downstream	CDA, 2014 and Directive 019, 2012
Short Term with Project Flood Event	1.3	Unspecified	Directive 019, 2012
Full or rapid drawdown	n/a	n/a	n/a

**Table 20-15: Minimum FoS for slope stability in construction, operation, and transition phases – seismic assessment**

Loading Conditions	Minimum FoS	Guideline
Pseudo-static	1.0	CDA, 2014
	1.1	Directive 019, 2012
Post-earthquake	1.2	CDA, 2014
Post-seismic	1.3	Directive 019, 2012

### Typical Cross-Sections

- **Dikes PFT-1 and PFT-2**

The plan is to build Dikes PFT-1 and PFT-2 according to a very similar cross-section consisting of a granular fill with an upstream inclined low permeability element. The low permeability element will include a bituminous liner system consisting in the membrane itself laid on top of an appropriate transition layer and covered by a granular protection layer. A bituminous geomembrane liner is recommended considering its versatility, its long construction period and its requirement for lesser base layer preparation. The total system thickness is in the order of 800 mm.

Crests of 12 m, upstream slopes of 2H:1V and downstream slopes of 3H:1V are planned for the dikes at this stage. Side slopes will require further adjustment depending on the granular fill to be used and the results of the stability analyses. In some cases, as demonstrated by the preliminary stability analyses for dike PFT-1 (Section 20.2.7.7), building of stability berms at the intermediate raise stages of the dikes may be required. These berms will be built with the granular fill material and will be part of the subsequent raises.

Dike PFT-2 will be built to elevation 335.25 m at the first stage of the TMF development to provide capacity for the polishing pond. Dike PFT-2 toe is expected to be flooded as long as the polishing pond is in operation. An upstream berm might thus be required to add weight and avoid liner uplifting from the hydrostatic pressure applied by the static water head of the polishing pond.

As mentioned, it is also planned to put underdrains in place in the PFT Cell if modelling results show the necessity of lowering the phreatic surface in the tailings mass and confirm the efficiency of such feature. These underdrains could be extended to dikes PFT-1 and PFT-2 downstream side, if required, passing under the low permeability element.



- **Dikes PCT-A and PCT-B**

The plan is to build dikes PCT-A and PCT-B similar to PFT-1 and PFT-2 dikes cross-section with the exception that the low permeability element will extend beyond the upstream toe of the dikes over the entire PCT Cell footprint.

- **Polishing Pond Cell Confining Dikes**

Confining the polishing pond cell is planned for the Stage 5 of the TMF operation. It is planned to build the Polishing Pond Cell dike PFT-3 according to a cross-section similar to dikes PFT-1 and PFT-2.

- **Median Dike**

The plan for the Median Dike is to build a rock fill structure with waste rock. A slurry trench or an equivalent low permeability system will be put in place to provide hydraulic separation between PFT and PCT Cells. A final crest width of 12 metres is planned for the Median Dike, but this width could vary depending on waste rock availability. A permanent pumping system will be installed at the PCT Cell side starting with the first stage of development for pumping bleed water from PCT during operation and at closure.

- **Internal Dike**

The internal dike will separate the PFT Cell from the internal pond. The plan is to build this structure as an entirely permeable feature using granular fill. A minimum of a 2.0-m wide transition layer system will be provided at the upstream side (towards PFT Cell) of the internal dike. This transition layer system will consist in several granular layers and a geotextile, in order to provide transition from the fine grained PFT to the granular fill and to prevent fines from being transferred to the pond. The system thickness and number of layers will be defined in the next stage of the design effort.

- **Borrow Sources**

Existing quarries and regional geological information support the potential for borrow sources development in the area of the surface TMF but actual sources for the granular fill, underdrain material, transition material, base layers and rockfill have not yet been identified. An extensive borrow search, including identification of the potential for quarry development, will be conducted during the detailed design phase of the Project.

Figure 20-15 to Figure 20-17 represent typical cross-sections of the PFT-1, Median and Internal Dikes, respectively.

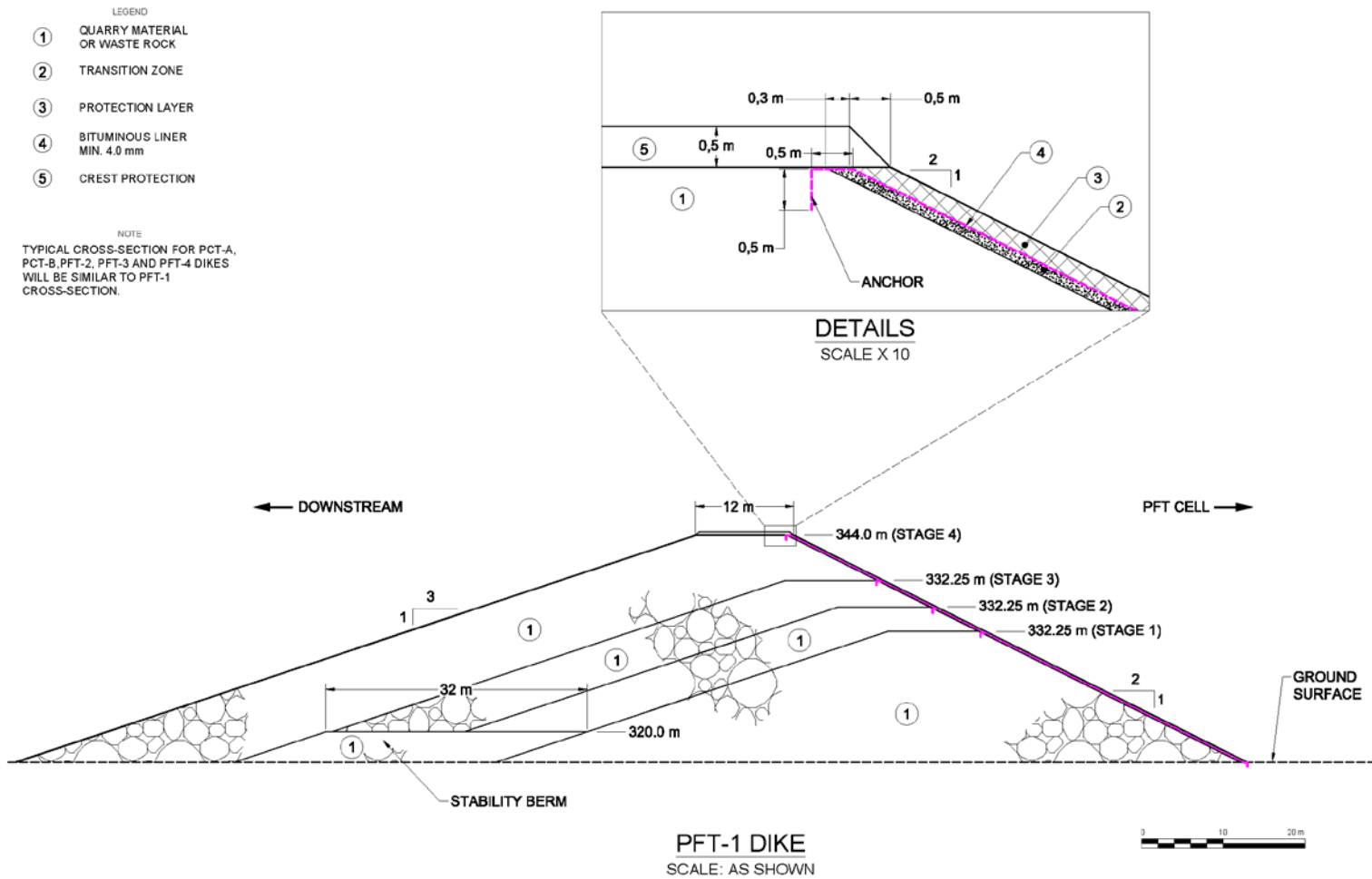

Figure 20-15: PFT-1 cross-section



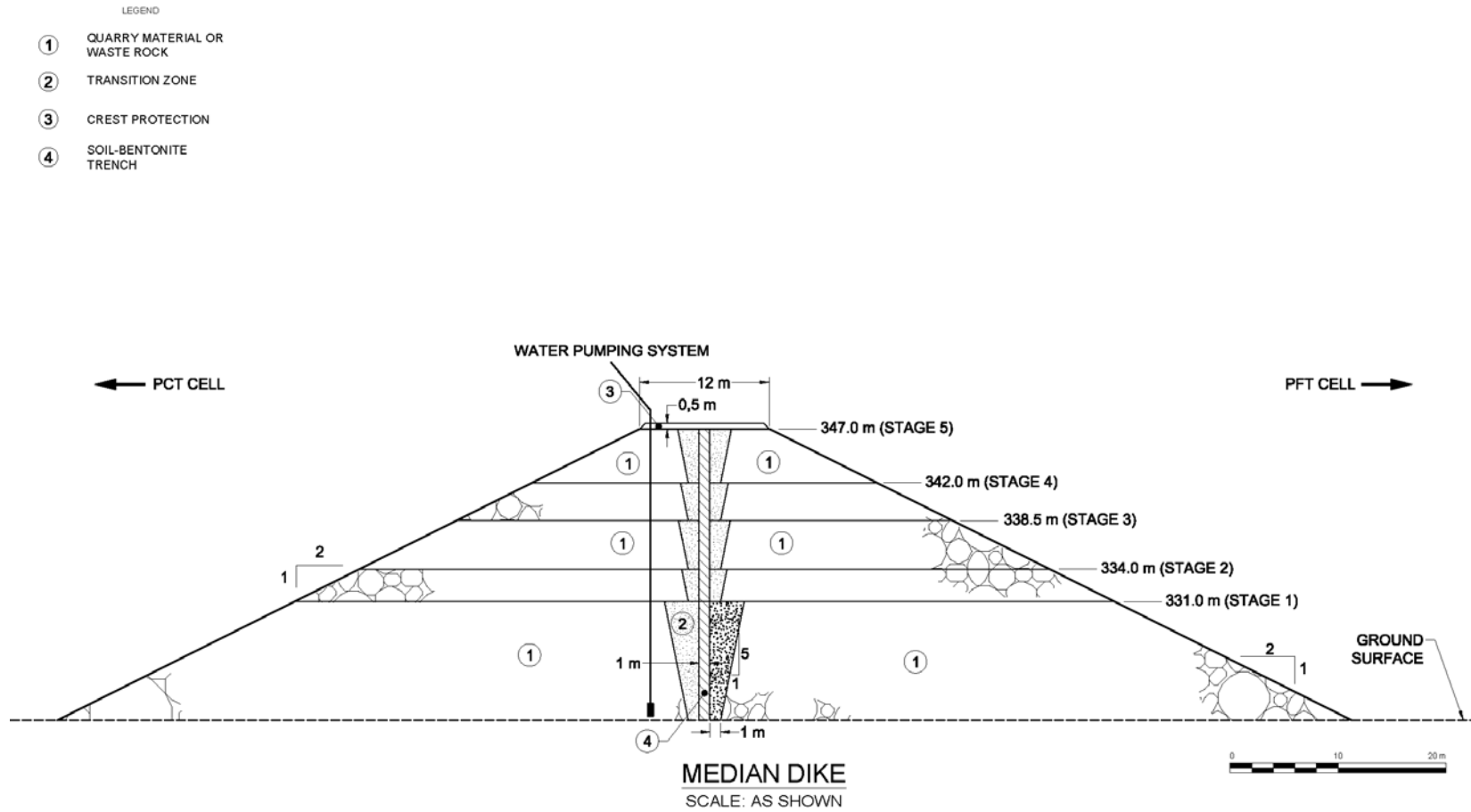

Figure 20-16: Median Dike cross-section

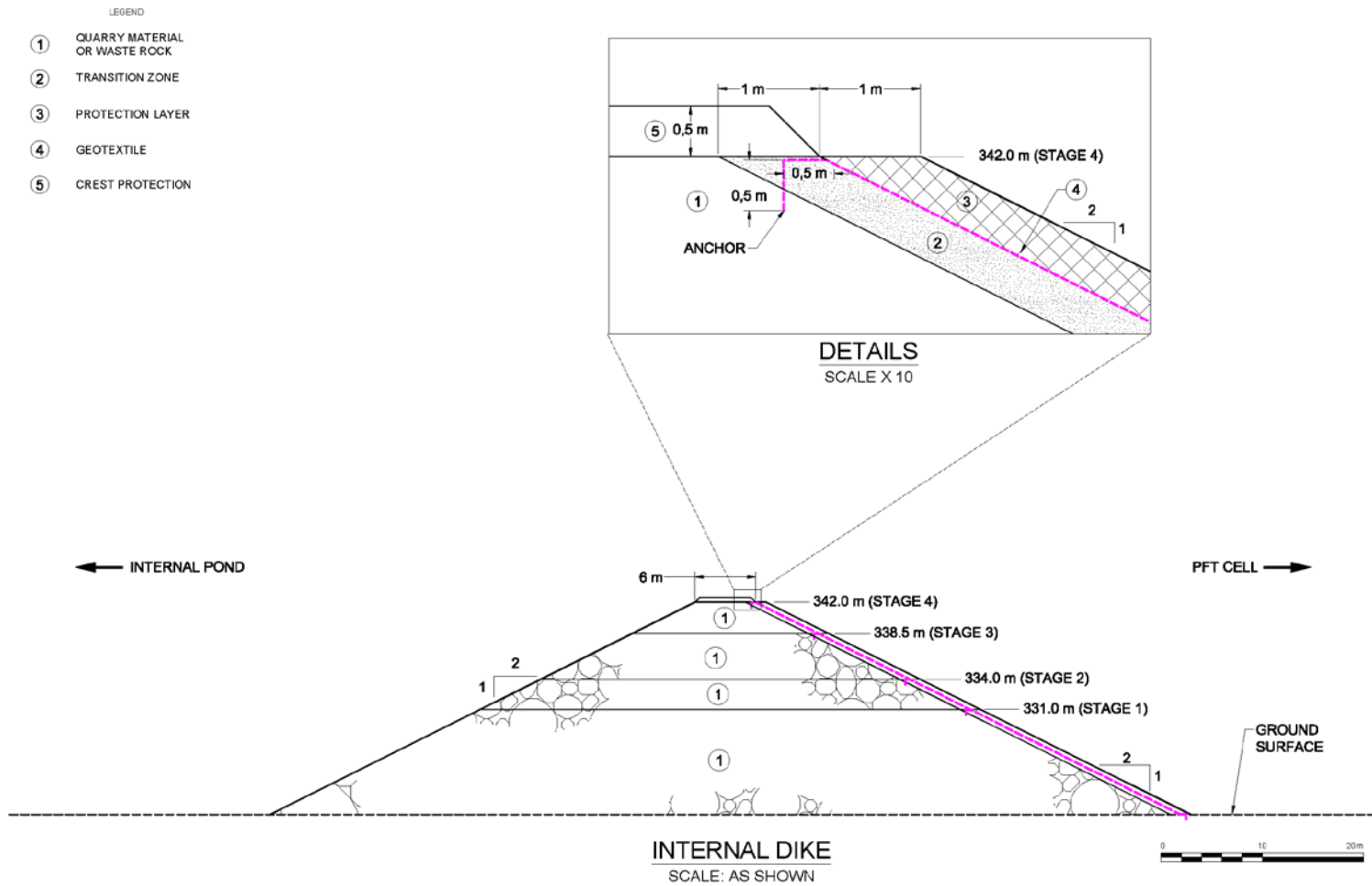

Figure 20-17: Internal Dike cross-section

### 20.2.7.7 Preliminary Design Analyses

#### Preliminary Stability Analyses – Dike PFT-1

Preliminary stability analyses were carried out for dike PFT-1, which is the highest structure to be put in place at the TMF. Limited geotechnical information is available for the TMF for the FS. Most of the historical data applicable to the new TMF infrastructure is located close to dike PFT-1 and could be used as an initial approximation and for a preliminary slope sizing. Detailed geotechnical investigations to be conducted at the detailed design stage will confirm foundation conditions, soil and tailings parameters.

Preliminary analyses were conducted under the following conditions for dike PFT-1:

- In static conditions, for the downstream face of the dike;
- In pseudo-static conditions, for the downstream face of the dike; and
- In post-seismic conditions, for the downstream face of the dike.

A method of analysis inspired from the one proposed by the “US Army Corps of Engineers” (1984) was used to perform these analyses. The US Army Corps of Engineers' method proposes using a seismic coefficient equal to 50% of the maximum bedrock acceleration, reducing the strength parameters of soils not susceptible to liquefaction by 20% and aiming for a FoS of 1.0. The analyses were carried out using a seismic coefficient of  $0.0375g$  corresponding to 50% of the estimated PGA (halfway between 1 in 2,475 years and 1 in 10,000 years) without attenuation to bedrock, which is considered to be a more conservative condition. However, in order to abide by the Directive 019 recommendation for a minimum FoS of 1.1, strength parameters were not reduced.

The liquefaction potential of foundation soils was not assessed due to the limited geotechnical information at hand. However, based on information from four existing boreholes performed in the vicinity of dike PFT-1, the subsoils consist mainly in silty clay, clay and till, which are stratigraphic units typically not susceptible to liquefaction. Liquefiable soils may be present in other areas where dikes are planned to be built and the assessment of their liquefaction potential should be performed once a detailed geotechnical investigation is conducted.

Hydraulically deposited, saturated tailings are known for their high potential for liquefaction under dynamic and static conditions. No dynamic testing has been performed on the tailings so far. However, for the purposes of this preliminary stability assessment, it was assumed that the tailings would liquefy under the design earthquake. Post-seismic analyses for dike PFT-1 were performed with the assumption that the entire tailings impoundment upstream of dike PFT-1 had liquefied.

### PFT-1 Geometry for Analyses

The preliminary stability analyses were performed for the four stages of the PFT-1 construction at crest elevations 332.25 m, 335.25 m, 338.5 m and 344.0 m. The cross-section used for the analyses corresponds to the typical cross-section described in Section 20.2.7.6.

Tailings deposition is planned to be done from dike PFT-1 pushing water away from it. Thus, there would be no ponding water against the dike under normal operating conditions. However, as described in Section 20.2.8.4, during the project flood event water will be allowed to overflow the internal dike and water level would rise. For the purposes of this preliminary stability assessment, the most conservative condition, even if hypothetical, of water levels corresponding to the design flood event was considered. In addition, even if analyses of this particular temporary condition is recommended by Directive 019 with a minimum FoS of 1.3 as per Table 20-11, an FoS of 1.5 for static analysis was targeted. The analyses in pseudo-static and post-seismic conditions also assumed high water level to be consistent with the static analyses.

The analyses conducted for the first stage of the TMF development (PFT-1 dike crest elevation of 332.25 m) were performed using the undrained shear strength of the clayey layer. All subsequent development stages were modelled using the drained properties for all soils. A reduction factor of 20% was applied to the soil properties in post-seismic conditions to account for possible cyclic softening of cohesive soils. It should however be noted that for the moment, very little information on the exact location of the PFT-1 dike exists. This reduction factor of 20% is typically applied to soil properties in post-seismic conditions to account for the potential strength softening where applicable. Verification of the reduction of soil strength will be performed on samples to be collected during the geotechnical investigation.

### Stratigraphy and Geotechnical Properties

Based on the review of the available documentation, four boreholes were drilled in the vicinity of dike PFT-1, namely TF-02, TF-03, TF-04 and TF-07. (Golder, 2000) The stratigraphy generally consists in clay followed by a layer of till overlying the bedrock.

The stability analysis were performed using the stratigraphy of boreholes TF-02 and TF-07. These boreholes were selected because they are located at the outer limit of the polishing pond, upstream of PFT-1 dike. The geotechnical properties were less restrictive than boreholes TF-03 and TF-04, which intercepted a very soft clay layer of approximately 10 m thick. If during the geotechnical investigation planned for the detailed design of the dikes such critical conditions are encountered, mitigation of the foundation will need to be performed. The mitigation measure could consist in soil excavation and replacement. Soil properties and detailed analyses results are presented in the Golder, 2017b report.

### Preliminary Results Summary

As discussed, the preliminary stability analysis for dike PFT-1 was performed using limited data. Stability analyses will be conducted when the geotechnical investigation and geophysical surveys are performed at the TMF site to determine the soil conditions along with refinement of the management schedule.

The current analyses demonstrated that minimum FoS are met for the site conditions analyzed. Due to the presence of clayey soils and considering the undrained shear strength used in the analyses, the first stage PFT-1 dike construction (crest elevation 332.25 m) will require the addition of a stability berm. As discussed, this berm should be built as part of the downstream fill to be put in place during subsequent construction stages. It should be noted that analyses of PFT-1 for subsequent stages were conducted in drained conditions because an improvement of the foundation is expected due to the surcharge and the relatively long time delay between each stage of construction. The analyses in drained conditions do not take into account the pore water increase in the clay layers due to the buildup of the facility. These analyses along with pore water distribution calculations will be performed at the detailed design stage when geotechnical information at the precise location of dike PFT-1 is available.

The installation of appropriate instrumentation, such as piezometers, inclinometers and settlement plates, among others, for all dikes is recommended for soil and structural behaviour during and after construction. A detailed instrumentation plan should be put in place at the detailed design stage of the TMF.

#### 20.2.7.8 Groundwater Protection

As discussed in Section 20.2.2 the ore, the tailings and the waste rock will require a management strategy meeting recommendations of Directive 019, though PFT, which reports a low sulphur content, demonstrate a delay to onset of acidic conditions in kinetic testing. The process water sample from each tailings stream shows exceedance of RES, *Drinking water*, and Directive 019 effluent criteria.

Both PCT and PFT will be stored at the surface TMF site, in two different cells. For the PCT, a low permeability liner will be placed at the foundation of the cell. Therefore, seepage of tailings pore water from the PCT Cell to groundwater is expected to be low and the groundwater protection objectives outlined in Directive 019 should be met.

For the PFT Cell, a hydrogeological study will need to be conducted in order to quantify the infiltration rate towards groundwater and to demonstrate that groundwater protection objectives outlined in Directive 019 are satisfied. This assessment will be performed once the hydrogeological conditions at the TMF site are characterized. The presence of surface water bodies and water wells in the area of the TMF site suggests that the MDDELCC's *Drinking water* and RES criteria should be used for the groundwater protection evaluation (Beaulieu, 2016).

#### 20.2.7.9 TMF Site Closure

The expected main impacts from the TMF in the long term are associated with the physical and geochemical stability of the facility. The design for closure concept has been adopted throughout the TMF design process and accounts for foreseeable impacts and identifies key closure issues likely to influence strategic direction of the Project.

The closure plan for the Project should integrate closure activities and cost for rehabilitating the TMF. Closure plan should be put together according to the requirements of the latest version of the Québec Government Closure Guidelines (MERN, 2016). The CDA, 2014 Technical Bulletin provides additional information and guidelines for closure planning and activities.

Closure of the TMF site typically consists of several phases: the transition phase where all construction and dismantling activities take place, the active closure phase where time is allowed for all components to reach a steady state and the passive closure phase where the system normally performs in a sustained manner.

#### Key Long Term Issues and Proposed Closure Concepts

Key long term issues for the TMF are associated with the geochemical performance of the PCT and PFT, as well as water management and its impact on the overall stability. The following paragraphs summarise the identified issues and present the proposed closure concepts to manage their long term impact.

- PCT Cell: From available geochemical testing, it is recognised that the PCT are potentially acid-generating and metal leaching. It is thus planned to install a low permeability bituminous liner to completely isolate the cell from the natural ground and to cover it with a HDPE liner to eliminate infiltration of natural precipitation into the tailings mass. The PCT being very fine tailings, they are expected to retain water. The Median Dike pumping system is thus expected to be operated during the transition period and into the active closure period to drain as much water as possible.
- PFT Cell: From available geochemical testing, PFT indicate weak acid generation potential that could develop after a period of exposure to surface conditions (kinetic testing). It is planned to assess the quality of the ground with respect to applying improvement measures to the foundation. The preferred method of rehabilitation of the PFT Cell is building a cover to limit either the infiltration, or the infiltration and the oxygen diffusion to the underlying tailings.
- Waste Rock: All produced waste rock is expected to be acid generating and metal leaching. It is planned to be used as construction material or be placed within the TMF footprint. The waste rock should be completely buried under the PFT tailings. Some management of its exposure to the elements, while deposited at surface will be required.

- **Internal Water Pond:** The PFT Cell will be built in a way to result in a constant slope for runoff towards the Internal Water Pond. In addition, pumping and maintaining low water level in the internal pond is expected to contribute to lowering the phreatic surface in the PFT and thus improve stability. It is planned to provide the Internal Water Pond with a permanent spillway, in natural terrain, at closure maintaining water level low in the long term. The Internal Water Pond can thus be used in the transition period for water quality control and later, during the active closure, as required. Later, when the TMF will transition towards the passive closure period, the pond should provide natural outlet for surface runoff.
- **Water management at closure:** The Internal Water Pond and the small polishing pond should be maintained during the transition period to monitor water quality while PCT and PFT covers are built. The need to maintain these ponds in operation is also to be assessed during the active closure period when seepage from different areas is expected to continue for some period and is pumped to the Internal Water Pond. The proposed closure strategy aims at gradually eliminating the need for active treatment and thus dismantling the polishing pond while the Internal Water Pond will remain as natural surface runoff outlet.

## 20.2.8 Water Management

The following sections describe the Project overall water management strategy. They set the concepts and principles that are proposed for the management of water throughout preproduction (initial dewatering and construction) and production (with and without TMF). Based on the water management strategy, design criteria and the site overall water balance, annual water volumes to be managed are estimated for both technical and economic feasibility assessments. Water management infrastructure sizing and corresponding quantity estimates are presented in Section 18.22, whereas infrastructure cost estimates are summarized in Chapter 21.

### 20.2.8.1 Water Management Overall Strategy

Throughout the different stages of the Project, water will have to be managed adequately to both limit the risks of impacting the environment and maximize the reuse for the mining operations. The following sections present the proposed water management strategies for each period of the Project. Throughout the life of the Project, water will be transferred to and from three main areas: the underground, the Horne 5 Mining Complex and the TMF site.

#### Preproduction Dewatering Water Management Strategy

The preproduction water management strategy diagram (Figure 20-18) presents the principles proposed for the management of water during the construction and initial dewatering phase.



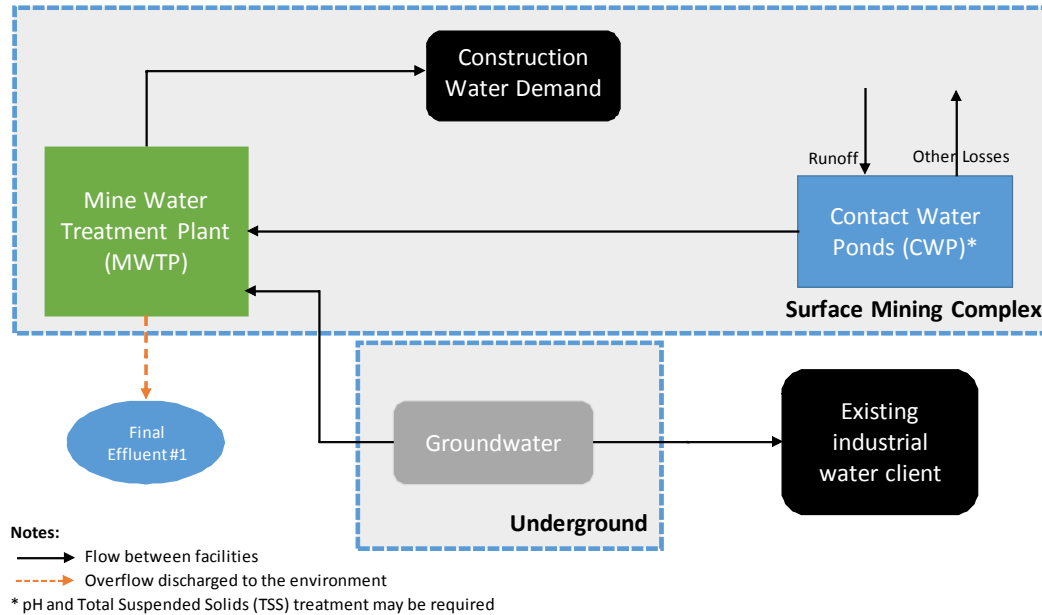

Figure 20-18: Water management strategy diagram – preproduction period

During preproduction dewatering, a total water volume of approximately 12.2Mm<sup>3</sup> is expected to be pumped from underground in order to dewater existing underground workings and lower the groundwater level to an elevation suitable for the start of the mining activities. Water from dewatering will be processed through an appropriate water treatment plant described in Section 18.23.

During preproduction, the surface infrastructure will be constructed. Surface water of the disturbed area (i.e., around the Horne 5 Mining Complex) will be collected through a network of collection ditches and ponds, and pumped to the mine water treatment plant, if necessary. A small portion of the water from the mine dewatering and the surface water collection system is expected to be used for dust control and for other construction needs, after adequate treatment if required.

The major portion of the dewatering water and the surface water collection system (excess water) will be treated at the Horne 5 Mining Complex. Water will then be monitored for quality before being discharged to the environment in the Dallaire watercourse. At the final effluent point, water will be monitored for quantity and quality control.

Water balance results are presented later in this section.

### Production Water Management Strategy

The production water management strategy diagram (Figure 20-19) presents water management principles proposed throughout the life of mine.

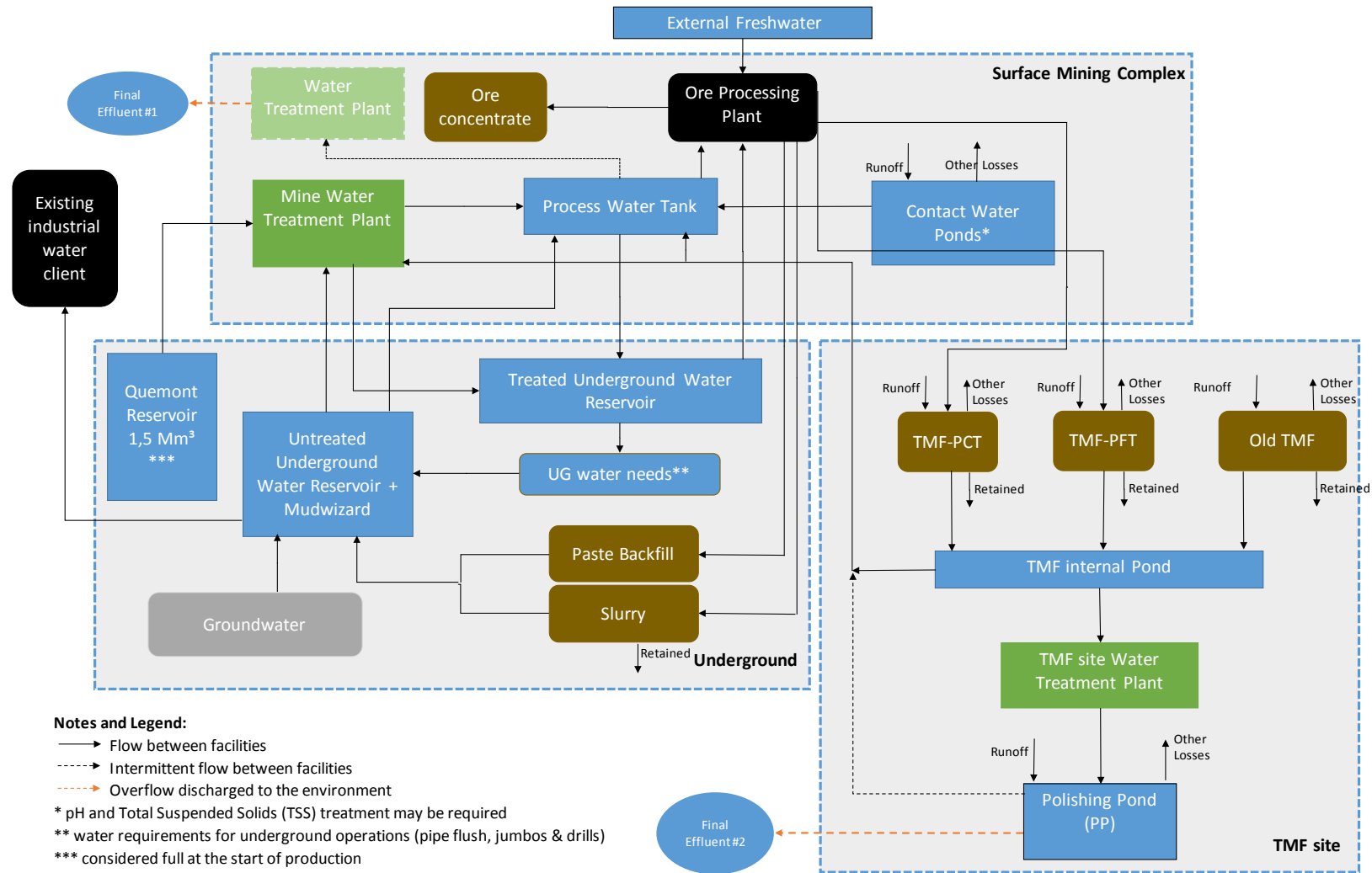

Figure 20-19: Water management strategy diagram – production period (with and without surface TMF)

The overall water management strategy during production targets the following:

- Process water requirements will be fulfilled, as much as possible, by mine infrastructure contact water and tailings bleed water after appropriate treatment if required, while freshwater intake from the environment will be limited as much as possible. Fresh water intake, when required, will be obtained from Lake Rouyn.
- Water release to the environment will be limited as water management infrastructure will be sized and set up with the objective to reuse mine and contact water for the process as much as possible. Discharge to the environment, when required, will be in the Dallaire watercourse.

The production is divided into two main periods:

- Production while tailings are entirely disposed underground (production without TMF): During the first years of production, PFT and PCT will be entirely deposited underground (slurry and paste backfill streams). No TMF will be operated at the surface during this period; however, construction of the TMF (at the Norbec site) will start.

Production while tailings are disposed at the surface (production with TMF): After a few years of operation, the portion of the PFT and PCT that will not be required for the paste backfill production will be deposited at the surface TMF. Water will be reclaimed from the TMF site for use at the process plant for process make up water and to reduce freshwater intake.

During production, with and without TMF, water to be managed will be coming from:

- Groundwater recharge to the underground mine;
- Tailings bleed water both from underground (production without TMF) and from the surface (production with TMF);
- Contact water collection systems both at the Horne 5 Mining Complex and at TMF site.

Water will be conveyed to and from the various installations using pumping and pipeline systems, both for tailings and water. The following sections present in more detail how water will be managed at both the Horne 5 Mining Complex and the TMF site and water balance results during the Project (preproduction, production without TMF and production with TMF).

### 20.2.8.2 Water Management Design Criteria

The following paragraphs present the guidelines and the main design criteria considered in the design of the surface water management infrastructure.

#### Guidelines

Recommendations from five different guidelines are taken into account in the design of the water management structures for the Project. Table 20-16 below presents the detailed references.

Table 20-16: Guidelines for water management

Guideline	Version
<i>Ministère du Développement durable, de l'Environnement et de la Lutte contre les changements climatiques – MDDELCC<sup>(1)</sup> « Directive 019 sur l'industrie minière » (Directive 019)</i>	2012 version
<i>Ministère de l'Énergie et de Ressources Naturelles « Guide de préparation du plan de réaménagement et restauration des sites miniers au Québec »</i>	2016 version
CDA “Dam Safety Guidelines” (CDA Guidelines)	2007 version
Technical bulletin of the CDA on the “Application of Dam Safety Guidelines to Mining Dams”	2014 version
Environment Canada Environmental code of practice for metal mines	2009 version

<sup>(1)</sup> “MDDELCC”: formerly known as *ministère du Développement durable, de l'Environnement, de la Faune et des Parcs* (“MDDEFP”), *ministère du Développement durable, de l'Environnement et des Parcs du Québec* (“MDDEP”), *ministère de l'Environnement du Québec* (“MENV”) ou *ministère de l'Environnement et de la Faune du Québec* (“MEF”).

#### Design Criteria

Table 20-17 lists the proposed design criteria selected for the design of the surface water management infrastructure for the operational phase of the surface TMF.

Table 20-17: Proposed operational design criteria for water management infrastructure

Aspect	Component	Design Criteria	Comments/Assumptions
Water collection and conveyance	Diversion ditch; collection ditch; collection pond capacity and pumping system	Conveyance of 1:100 year peak runoff event without overflow	As recommended by Environmental Code of Practice for Metal Mines
	Ditch freeboard	Minimum of 0.50 m	Freeboard is defined above calculated water depth
TMF and Polishing Pond water management structures	Water storage and pumping capacities	Normal operating water levels (“NOWL”) based on water balance results for average climate conditions	NOWL is calculated from the maximum water storage over the TMF operational phase for the average climate year.
		Containment of the design flood (“ <i>crue de projet</i> ”) defined in Directive 019 without spillage to the environment	The design flood is a combination of a 24-hour precipitation with a return period of 2,000 years and the snowmelt from a snow accumulation with a return period of 100 years over 30 days.
	Freeboard (measured between the design flood max water level and the dike crest)	1.5 m (for TMF dikes)	As recommended by Directive 019 where a TMF is located upstream of a sensitive environment.
		1.0 m (for polishing pond dike)	Smallest freeboard for the polishing pond is justified by the fact that the water will be treated before storage. Consequently, this water will be of a quality that should be better than or close to the acceptable water quality for release to the environment.
	Spillway	Convey the Probable Maximum Flood (“PMF”) without overtopping dike crest	Assuming that the initial water level is at the design flood water level prior to the occurrence of the PMF.
		For the TMF, the emergency spillway invert elevation will be at least 0.5 m lower than the TMF lowest dike crest	For Stage 1 of the TMF development, no emergency spillway will be constructed on the TMF, as it will have enough capacity for PMF storage.
		For the PCT Cell, the operational spillway invert elevation will be located above the NOWL.	During a flood event, this spillway allows a hydraulic connection between the internal pond, the PFT Cell and the PCT Cell.
		For the polishing pond, the emergency spillway invert elevation will be at least 1.0 m lower than PFT-2 dike crest	Spillway invert will remain at the same elevation over all operation stages.

### Main Input Data

Key input data that have been considered for the water management infrastructure design and water balance modelling of the Project include:

- The site topography (LiDAR produced in 2016 for Falco) and hydrography (based on Québec provincial mapping);
- Horne 5 Mining Complex site layout (described in Chapter 18);
- The Norbec site existing infrastructure, layout and water balance (Norbec site owner, GoogleEarth, Provincial mapping);
- Information on the preproduction and production schedule (see Chapter 16);
- Information on the ore process plant water requirements and tailings production (see Chapter 17);
- Regional and local climate (Golder 2017b).

### Water Management at Closure

At closure, surface water management infrastructure at the TMF site will be either decommissioned or modified as follows (see Table 20-18). Decommissioning of water management infrastructure will be done in accordance with the active and passive closure and post-closure water management plan:

**Table 20-18: Required modification on TMF water management infrastructure for closure**

Structure	Required Modifications for Closure
Collection ditches	To be preserved to drain downstream dikes slope. If required, slopes will be stabilized and walk-away design should be implemented.
Pumping basins	To be decommissioned and reclaimed.
Diversion ditches	To be preserved as permanent diversion. Walk-away design should be implemented.
Spillways	To be preserved as water channels, and will be modified according to the active and passive closure and post-closure water management plan. Walk-away design should be implemented.
Pumping systems	Pumps and pipes to be decommissioned and removed from site.

### 20.2.8.3 Horne 5 Mining Complex Surface Water Management Strategy

As per the overall water management strategy, surface water infrastructure will be built at the Horne 5 Mining Complex in order to adequately collect runoff water from this area. This infrastructure will maximize the reuse of disturbed area runoff water to fulfill the project's needs.

Based on the future site topography, the ditches and pumping basins were positioned as shown in Figure 20-20. Due to a favorable topography, the Horne 5 Mining Complex watersheds are limited to the process plant platform boundaries, as very few runoff is expected to drain from the outside to the site.

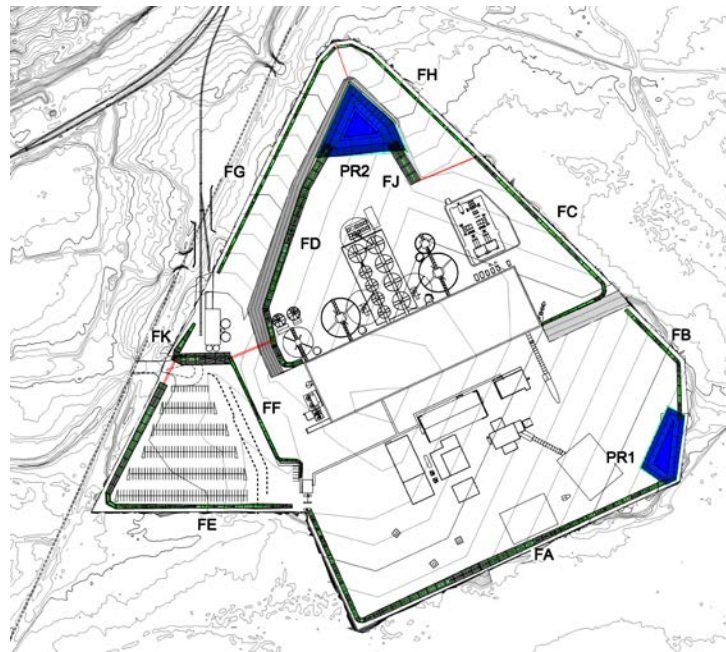

Figure 20-20: Water management at the Horne 5 Mining Complex – ditches and pumping basins

### 20.2.8.4 TMF Site Surface Water Management Strategy

The TMF site surface water management strategy described in the following sections has been developed in conjunction with tailings management planning. Both tailings and water management strategies are deeply interconnected and form the basis of the TMF design. The following sections relate to water management during the TMF operation (production with TMF) only, as conceptually described in Figure 20-21. Stages of the TMF development including water management infrastructure development are presented in detail in Figure 20-8 to Figure 20-14 in Section 20.2.7.4.



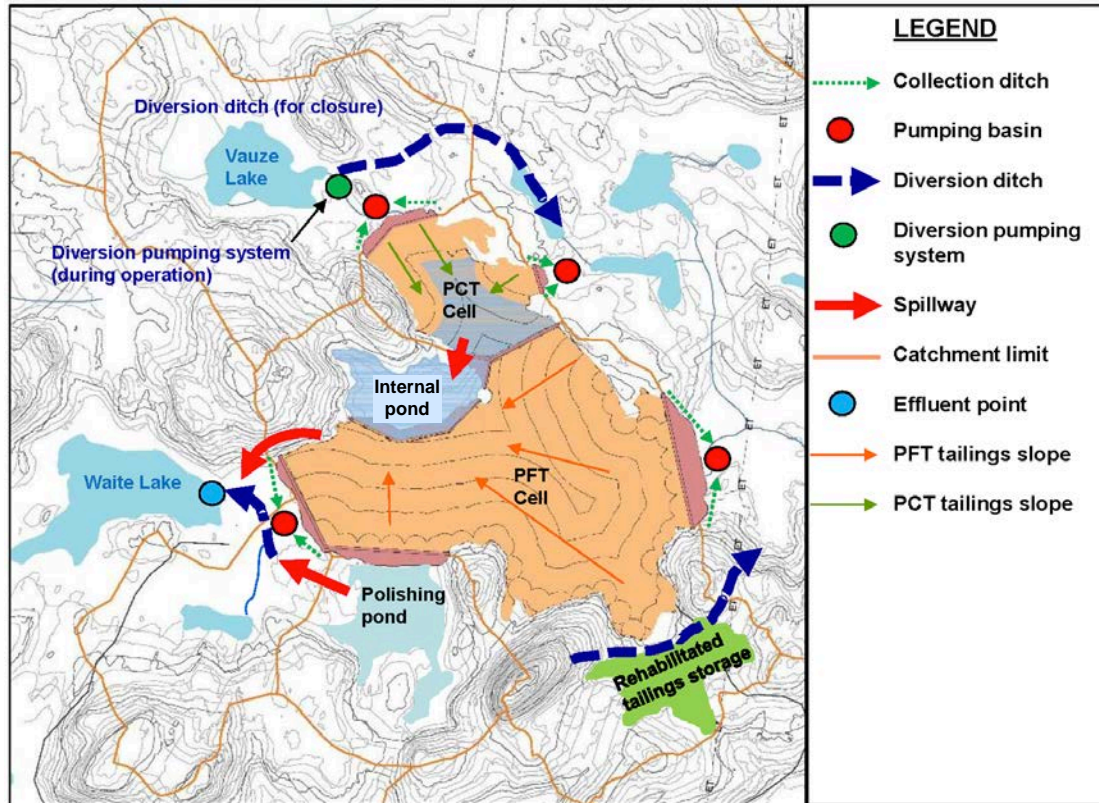

Figure 20-21: TMF surface water infrastructure (End of Stage 4)

The actual design, sizing and construction quantities relative to the water management infrastructure at the TMF site are presented in Chapter 18.

The water management strategy specific to the TMF includes the following:

- Divert main natural water body draining towards the TMF, to limit mixing of non-contact water and contact water;
- Limit the risk of non-treated water discharge to the environment.
- Collect all seepage at the toe of dikes;
- Prioritize the reclamation of water from the TMF site to the process plant (after treatment if required) over external freshwater intake;
- Have one single effluent point (Waite Lake).

### TMF Internal Pond and PCT Cell Pond

The tailings deposition, as currently envisioned, will create surface slopes oriented towards the Median Dike, for the PCT Cell, and towards the internal pond, for the PFT Cell. This deposition strategy grants that, under normal climate conditions, bleed water and surface runoff will be naturally conveyed and remain contained in the Internal pond and against the Median Dike, enhancing the drainage of the tailings surface (tailings beaches) and lowering the phreatic surface within the tailings mass.

Water from the internal pond will be pumped to the process plant as reclaim water or to the TMF water treatment plant. The polishing pond will act as a retention basin where the water treatment will be finalized and from which water will be discharge to the environment. Pumping systems and water treatment capacity during operation will be designed to ensure that the water level inside the TMF is maintained at a low level.

An operational spillway will allow excess water from the PCT Cell to drain towards the TMF internal pond. The crest of the Internal dike and the operational spillway of the PCT Cell will have lower elevations than external dikes crests (PFT-1, PFT-2, PCT-A and PCT-B). This configuration allows a hydraulic connection between the PCT and PFT Cells, and also allows the design flood to be managed inside the TMF, with part of the tailings beaches being submerged by the flood.

Towards the end of the TMF Stage 1 (after about two years of TMF operation), an emergency spillway will be constructed in the natural ground at the western end of the TMF to direct all overflow towards Waite Lake. For TMF Stage 1, no emergency spillway will be constructed in the TMF, as it will have enough capacity to store both the design flood and the Probable Maximum Precipitation (“PMP”).

The final stage of the TMF development plans for overtaking the polishing pond and building a new smaller pond downstream of dike PFT-2 and PFT-3. This construction is planned to take place in 2033 while development is planned to start in 2034. PFT bleed water management by pumping will be required for a short period before deposition is moved to high topography points for final configuration. No new external runoff will be managed and the water management strategy for that stage remains similar to the one described above.

### Seepage and Contact Water Collection Systems

Collection ditches and sumps constructed downstream of TMF dikes will collect seepage from the dikes and some limited land area including the downstream dike slope. Water collected on collection sumps will be pumped back to the internal pond inside the TMF.

### Surface Water Diversions

Two water bodies and runoff from an area draining towards the TMF will be diverted:

- Vauze watercourse (downstream of Vauze Lake) will be diverted towards a downstream point of Vauze creek by a pumping system, during the TMF operation and closure phases, and by a diversion ditch for post-closure;
- An existing stream, southwest of the TMF site, will be diverted by a diversion ditch to securely convey the runoff from this catchment through to Waite Lake;
- A diversion ditch southeast of the TMF will collect and securely convey the runoff from the Norbec rehabilitated tailings management facility to a downstream point of Vauze creek, if the water quality of the rehabilitated area satisfies environmental discharge criteria; or alternatively, it will convey the collected water to the TSF water treatment plant.

### Polishing Pond and Final effluent

The polishing pond will be formed by the PFT-2 dike, and will contain the excess water from the TMF. Water will be treated at the TMF water treatment plant prior to discharge into the polishing pond. An emergency spillway will be constructed on the western side of the polishing pond to direct all potential overflow towards Waite Lake, where the final effluent will be located.

At stage 5, when the polishing pond will be overtaken by PFT deposition, the supernatant water will be transferred by pumping to the internal pond. A small pond should then be built to handle excess water after treatment for the last years of operation.

### Consideration for Water Management at Closure

Closure of the TMF site would typically consist of several phases: transition phase where all construction and dismantling activities take place, active closure where time is allowed for all components to reach a steady state and passive closure where the system normally performs in a sustained manner. Water treatment is usually maintained during transition and active closure, and could be replaced by passive treatment systems in the passive care phase. Duration and need for water treatment will depend on the performance of the implemented closure measures and maintenance.

#### 20.2.8.5 Potential Impacts of Climate Change to the Overall Water Management Strategy

The International Council on Mining and Metals (“ICMM”) has identified a growing awareness that a changing climate and its impacts can affect the mining industry (ICMM, 2013). Over time, changes to long-term trends or extreme climate events may exceed infrastructure design parameters, or changes to the mine operations may decrease the original design capacity.

While assessing how climate change should be accounted for in a specific project and for a specific structure, important elements to consider are:

- The robustness of the initial design;
- The lifetime design of a particular structure;
- The vulnerability/sensitivity of the downstream environment that could be impacted by the failure or under design of a particular structure.

Considering that:

- The climate change projections are made for long-term perspectives (the time horizons considered in climate change models generally go from 2041 to 2100);
- The Horne 5 Mine is currently planning to have a LOM of about 15 years, which means that, according to the current mine plan, operations should cease before 2036;
- It is proposed that climate change should not be directly taken into account for water management structure operational designs: all Horne 5 drainage structures are designed for extreme events based on statistical analysis of historical climate data, which includes recent years, without accounting directly for climate change. A cost benefit assessment will need to be undertaken during the detailed design stage of the Project's development and climate and site condition projections will need to be reassessed periodically during the LOM. Such periodic assessments will help monitor the potential changes in climate and conditions (such as the duration of the LOM itself) that may affect the Project's infrastructure.

As necessary, the design of the Project's infrastructure will be reviewed following such assessments. Any structure to be left in place after rehabilitation and closure will require design reassessment before closure of the mine takes place.

#### 20.2.8.6 Project Water Balance

The water balance model was set up as a daily time step continuous model in GoldSim software to capture the progression from the preproduction dewatering through to the end of operations. The main purpose of the water balance is the estimation of water collected and stored at each water management facility, pumping rates between facilities and discharge volumes to the environment. The GoldSim site water balance integrates flows across the mine facilities on a daily basis assuming the mean climate conditions throughout the modelling period.

The following stages of the Project were modelled:

- Preproduction (during which the initial underground dewatering and Horne 5 Mining Complex construction take place);
- Production without TMF (production while all tailings are sent underground);
- Production with TMF (production while tailings not used for cemented paste backfill are sent to the surface).

Golder prepared a consolidated climate data set between 1950 and 2016 from the EC Rouyn and Noranda climate stations to represent the climatic conditions on site (Golder, 2017c).

Various years of recorded daily precipitations were compared with the calculated multi-annual mean year in order to select a year representative of the mean climatic conditions encountered on site. The hydrological year 2002-2003 is the most representative of average climatic conditions and is therefore used throughout the modelling period as “the average climate year”. The 2002-2003 hydrological year has an annual mean precipitation of 866 mm, an annual lake evaporation of 654 mm and an annual potential evapotranspiration of 797 mm. The 2007-2008 is the wettest hydrological year of the dataset, and is therefore considered the typical “wet climate year” with an annual mean precipitation of 1,037 mm, an annual lake evaporation of 629 mm and an annual potential evapotranspiration of 733 mm.

The following sections present details of the main water management components/areas and results of the water balance model.

### Horne 5 Mining Complex

As described in Section 20.2.1.2, two streams of tailings will be generated by the mine operation and will be distributed either underground or at the surface TMF once available, at various consistencies and blends.

Water recovered from the various steps of processing of both tailings activities will be pumped back to the process plant as process water. Makeup water requirement has been calculated to balance water losses in the Process plant associated with the ore product and the tailings activities.

Makeup water requirement will be supplied, as required and after appropriate treatment, from the following sources, in priority order, as follows:

1. Contact water ponds.
2. Underground mine dewatering, (including tailings bleed water from underground during the first years of production).
3. The TMF site water (including bleed water, runoff on collected areas and direct precipitation on ponds).
4. External freshwater intake, identified at Lac Rouyn.

## Horne 5 Mining Complex and Underground

Bleed water from settling and consolidation of underground deposited tailings, both as paste and slurry backfill, will be collected and pumped underground and used as mine field equipment or process makeup water (after appropriate treatment, when required). Horne 5 Mining Complex runoff will be collected by a network of collection ditches and conveyed by gravity towards contact water ponds to allow sediment settlement. Water accumulated in the contact water ponds will be returned to the process plant as makeup water after appropriate treatment, if required.

### Surface TMF Site

The TMF will consist of two deposition cells (PCT Cell and PFT Cell), including their associated water ponds, the TMF Internal pond, which will serve as the main TMF pond where all contact water will be conveyed and two polishing ponds; one being constructed for the first four stages and one smaller for the fifth stage in the TMF life.

Collection ditches and sumps will be constructed downstream of the cells to collect seepage and runoff. Water collected in collection sumps will be pumped back to the internal pond or the TMF Cells. Water from the PFT Cell will be drained through the Internal dike into the internal pond and water from the PCT Cell will be pumped into the internal pond. Water from the internal pond will be preferentially pumped to the process plant to be used as process makeup water, and, as required, to the TMF water treatment plant and the TMF polishing pond. Depending on the actual needs, water may be pumped from the polishing pond to the process plant. Any excess water will be discharged to the environment, i.e., Lake Waite, from the TMF polishing pond after appropriate treatment, if required.

### Water Balance Results

The following paragraphs present the main results of the water balance modeling completed according to the flow diagrams presented in previous sections. These results have been used to define normal operating water volumes and levels in the main TMF ponds, as well as water treatment requirements in terms of quantity.

An average of 80 m<sup>3</sup>/h is planned to be sent to an existing industrial client during the 3 periods.

- **Preproduction**

A water demand of about 40 m<sup>3</sup>/hr on average for construction activities at surface is expected to be required during the preproduction. This water is planned to be taken directly from underground. The excess water of approximately 575 m<sup>3</sup>/hr on average (approximately 5 Mm<sup>3</sup>/y) will be discharged to the environment during this period.



During this period, Norbec site water balance remains independent from the Horne 5 Mining complex and is assumed to be similar to its current conditions.

- **Production without TMF**

An average water demand of about 360 m<sup>3</sup>/hr is estimated to be required for the operations during the production without TMF period. Approximately 260 m<sup>3</sup>/hr will need to be freshwater, coming either from an external source or the mine water treatment plant. The balance, i.e., approximately 100 m<sup>3</sup>/hr on average, will be recirculated without treatment.

The process water tank will receive water from the contact water ponds and the underground, via the mine water treatment plant as necessary. It is estimated that an annual average rate of 60 m<sup>3</sup>/hr will be treated. The remaining 200 m<sup>3</sup>/hr of the freshwater demand will be fulfilled from an external source identified as Rouyn Lake.

No discharge of water to the environment is expected to be needed during this period, as process makeup water demand will exceed volume that will be recovered from surface and underground. Water that would need to be released due to climatic and operational events, would have to be treated to meet environmental criteria for discharge. Such discharge is expected to remain limited in time and volumes, thus not included in the water balance and the water management infrastructure at this stage.

- **Production with TMF**

During production with TMF, the reclaim water pipeline will connect the mine and the TMF and will enable water to be recycled from the TMF site to the process plant at an average flow rate of approximately 66 m<sup>3</sup>/hr to partially fulfill the process makeup water demand and decrease the need for external freshwater intake accordingly.

A make-up water volume of 3.2 M m<sup>3</sup>/year will be required for the operations during this period. About 0.8 Mm<sup>3</sup>/y (approximately 95 m<sup>3</sup>/hr) is expected to be fulfilled by the contact water collected at the mining complex (contact water ponds – 16 m<sup>3</sup>/hr on average), underground (Quemont Reservoir – 12 m<sup>3</sup>/hr on average) and the recycled water from the TMF (TMF internal pond via the reclaim water pipeline - 66 m<sup>3</sup>/hr on average).

The rest of the make-up water (approximately 2.4 Mm<sup>3</sup>/y or 270 m<sup>3</sup>/hr on average) will be freshwater from an external source (Lac Rouyn).

The total discharge to the environment is estimated at 2.7 Mm<sup>3</sup>/y under average climate conditions. The TMF water treatment plant will receive and treat this volume, i.e., 303 m<sup>3</sup>/hr, from the TMF area before releasing it into the polishing pond for treatment completion and discharge to the environment at the final effluent point, which will drain into Lake Waite.



### 20.2.9 Site Water Quality Predictions

A preliminary site water quality model was developed to predict the quality of mine contact water associated with the Horne 5 Project. The objective of the modelling exercise is to estimate future water quality in support of water management and water treatment by evaluating parameter concentrations at the order-of-magnitude precision level. While it is believed that the modelling approach and resulting water quality estimates presented herein are justified and appropriate for evaluating potential water management and water treatment options associated with the Project, the modelling exercise is evolving as water and waste management are being defined and more site chemistry data is becoming available. As such, the predictions of water quality should be considered valid as order-of-magnitude values for the current water and waste management plans only, and may change if these or other factors or scenarios are modified. The water quality design basis for water treatment used for the water treatment strategy and design is presented in Chapter 18, Section 18.23.4.

The water quality predictions were completed using PHREEQC (Version 3.2.0), which is a geochemical equilibrium speciation and mass-transfer code that is designed to perform a variety of low-temperature aqueous geochemical calculations, including chemical speciation and mineral saturation indices using water quality input data, assuming thermodynamic equilibrium conditions (Parkhurst and Appelo 1999). The model evaluates a comprehensive suite of parameters, including major ions, total cyanide, nutrients, i.e. total nitrogen, phosphorus, and dissolved metals, in order to evaluate results against the Directive 019 effluent guidelines.

Chemical source terms representative of the mined material were assigned using geochemical test results (Section 20.2.2) and available site water quality data from Horne 5 Mining Complex and Norbec sites. These include waste rock contact water from laboratory leaching tests, PCT, PFT, solids chemistry and leaching test results, process water quality after cyanide destruction by Caro's Acid, Quemont and REMNOR Shaft water quality, and available water quality monitoring data from the Norbec site. The calculated source terms were evaluated to identify parameters of environmental interest; parameters that exceed the Directive 019 effluent guideline in one or more of these source terms: pH (<6.5), total cyanide, copper, iron, nickel, and zinc. Other parameters of environmental interest include sulphate, nitrogen species (e.g. nitrate, nitrite, and ammonia), and cyanide species and their degradation products (e.g. free cyanide, weak acid dissociable ("WAD") cyanide, thiocyanate) since their concentration must be considered in water treatment design.

Chemical source terms were mixed together based on relative flow proportions estimated from the water balance model for the different production periods in order to predict future water quality for the following scenarios:

- Scenario 1: TMF, representing the inflow to the TMF water treatment plant:
  - Preproduction and Production without surface TMF: Water quality prediction modelling was done with the assumption that inflows include existing tailings contact water quality (Duprat Basin), natural ground runoff, and precipitation. No new tailings deposition; inflow to the water treatment plant is solely from the existing tailings contact water and represents acidic conditions. Waste rock contact water was not considered at this time.
  - Production with Surface TMF: tailings deposition at Norbec; Water quality prediction modelling was done on the assumptions that inflows to the water treatment plant is represented by:
    - 1a) average annual flow proportions (27% acidic water from the Duprat Basin and PCT runoff; 34% alkaline water from PCT and PFT infiltration and PFT runoff; and 12% natural runoff). These proportions were calculated based on approximate annual flows and are not representative of seasonal flow distribution.
    - 1b) acidic conditions represented by Duprat Basin water quality only (100%). This represents poor end water quality, based on data in hand at the time of modelling.
- Scenario 2: Horne 5 Mining Complex, representing the Mine Water Treatment Plant (preproduction) and process plant (production):
  - 2a) Preproduction: Water quality prediction modelling was done on the assumptions that water quality average from the monitoring conditions in Quemont shaft mixed in PHREEQC with applied mineral control were predicted. At the moment of completing the water quality modeling, the historic Horne No.4 (“REM NOR”) shaft monitoring results were not available. The water quality used as design basis for the preproduction water treatment strategy is presented in details in Section 18.23.4.
  - 2b) Production (with and without TMF): Water quality prediction modelling was done on the assumptions that inflows include contact water pond (runoff from Horne 5 Mining Complex), underground tailings bleed water, Mine Water Treatment Plant outflow, and TMF water treatment plant outflow. The current process plant water quality requirements assumption considers that water can be recycled from the Process Tank without treatment. Only a portion (60 m<sup>3</sup>/h) is planned to be treated for pH adjustment at the Mine Water Treatment Plant. The water quality used as design basis for the Production water treatment strategy is presented in details in section 18.23.4.
    - The Mine water treatment plant outflow quality was determined in PHREEQC using the Quemont Shaft water quality and anticipated lime dosing rates.
    - The TMF water treatment plant outflow quality was determined in PHREEQC using the plant inflow quality for Production with Surface TMF Scenario 1a (average flow proportions) and Scenario 1b (acidic conditions represented by Duprat Basin water quality), and anticipated lime dosing rates.

The following assumptions are considered in the model, and will be evaluated during future model revisions as new data becomes available:

- The Mine water treatment plant outflow quality is determined using the Quemont shaft water quality only, as the water quality analyses for samples from the historic Horne No. 4 (REMNOR) shaft were not available at the time of modeling. REMNOR shaft water quality represents a more charged water than the Quemont Shaft, and could result in higher concentrations of sulphate, iron, and metals in the treatment plant outflow, which reports to the process plant as reclaim water. Both the Quemont and REMNOR shaft waters are acidic;
- The underground water quality during Production will be impacted by the tailings bleed water from slurry and cemented paste backfill which is anticipated to be alkaline. This was modelled as being collected and managed separately from the inflow to the underground workings, which is anticipated to be acidic and highly charged, although it is understood that the underground water will be mixed and collected together;
- Cyanide destruction by Caro's Acid will target treatment down to 5 mg/L total cyanide in the tailings slurry;
- Process plant effluent quality was assumed to be constant through mine life. No upcycling of mass was considered;
- Water treatment plant sludge management nor its effect on any site water quality is not included in the model;
- By-products of explosives residues (e.g. nitrogen species) are not considered and will likely add a load of nitrogen to water quality (particularly in the form of nitrate and ammonia);
- Underground water quality during Production does not include treated process tank water that is anticipated to be used to flush paste backfill boreholes;
- It is assumed that waste rock will be submerged quickly in the TMF in order to limit the development of acid rock drainage. Therefore, waste rock contact water is not considered in the model at this time. Should waste rock be exposed and allowed to acidify without control, this would increase the chemical charge of water quality to the TMF water treatment plant.

Results of the water quality prediction modelling are summarized in Table 20-19 for selected parameters of interest to water treatment including all parameters that have a Directive 019 effluent criteria.

Table 20-19: Summary of preliminary water quality predictions, order-of-magnitude estimates

Parameter	Unit	Québec Directive 019 Effluent Guideline	Preproduction Dewatering		Scenarios 1a and 1b Norbec WTP Inflow – Production with TMF	Scenario 2b Process plant Inflow – Production with and without TMF
			Scenario 2a Quemont Shaft <sup>(1)</sup>	REM NOR Shaft <sup>(2)</sup>		
pH	s.u.	<b>6.5 – 9.0</b>	<b>3.8</b>	<b>3.4</b>	<b>3.6 – 4.6</b>	7.6 – 8.0
Sulphate (SO <sub>4</sub> )	mg/L	-	12,000	47,000	400 – 1,000	1,900 – 6,600
Total Cyanide (CN)	mg/L	<b>1.0</b>	0.01	-	< 3.0	0.1 – 2
Nitrate + Nitrite (NO <sub>3</sub> +NO <sub>2</sub> )	mg/L	-	0.9	5	1 - 40	0.01 – 30
Ammonia (NH <sub>3</sub> )	mg/L	-	0.5	30	3	<0.0001 – 0.1
Arsenic (As)	mg/L	<b>0.2</b>	0.005	0.001	<0.05	<0.0001
Copper (Cu)	mg/L	<b>0.3</b>	0.01	0.02	<b>5</b>	< 0.0001 – 3
Iron (Fe)	mg/L	<b>3.0</b>	<b>3,000</b>	<b>18,000</b>	0.02 – 20	0.0002
Lead (Pb)	mg/L	<b>0.2</b>	0.0004	0.002	0.03	0.00002 – 0.001
Nickel (Ni)	mg/L	<b>0.5</b>	0.03	0.05	<0.03	0.03
Zinc (Zn)	mg/L	<b>0.5</b>	<b>5</b>	<b>200</b>	<b>-5-20</b>	<b>5 – 10</b>

<sup>(1)</sup> represents average of historical monitoring conditions mixed in PHREEQC with applied mineral controls

<sup>(2)</sup> represents average water quality of current conditions (March 2017)

**Bolded** values represent concentrations above Québec Directive 019 Effluent Criteria

The water quality from the preproduction dewatering is anticipated to worsen (get more charged, possibly more acidic) with depth. Based on sampling to date (down to 600m from surface), it is expected to be acidic (pH <4), with elevated sulphate, iron, zinc, ammonia, and thiospecies. These parameters will require treatment. All other parameters were observed to meet the Directive 019 effluent criteria before being discharged to the environment.

The TMF water inflow to the TMF water treatment plant during preproduction and production without TMF will consist primarily of existing tailings contact water (represented by the current Duprat Basin; acidic and high chemical charge). During production with TMF (active tailings deposition), conditions are anticipated to continue to be acidic, with sulphate, iron, and zinc concentrations requiring treatment. All other parameters were predicted to meet the Directive 019 effluent criteria.

The Mine Water Treatment Plant will receive water from both the Process Tank and Norbec internal pond. Depending on the treatment efficiency achieved, the water could see elevated concentrations of sulphate, nitrate and nitrite, and the following above Directive 019 effluent criteria: total cyanide, copper, and zinc. However, this water will not be discharged to the environment. Predictions are provided in support of process plant design.

The water quality modelling completed to date does not define effluent discharge water quality (from the Mine Water Treatment Plant and from the TMF Water Treatment Plant). Effluent quality will be defined by water treatment targets (see Chapter 18, Section 18.23)

## 20.3 Regulatory Context

### 20.3.1 Environmental Impact Assessment Procedure

#### Provincial Procedure

The environmental impact assessment (“EIA”) process in the province of Québec is based on two regimes: Southern and Northern Québec. By its location, the Horne 5 Project is under the southern Québec regime, which corresponds to the Division IV.1 of the EQA (c. Q-2). Thus, every person wishing to undertake the realization of any of the projects subject to the *Regulation Respecting Environmental Impact Assessment and Review* (Q-2, r.23) must undergo the EIA and review process to obtain a certificate of approval(s) (“CoA”) from the provincial government. The Horne 5 Project is submitted to the provincial EIA process.

**According to Division II 2(p) of the *Regulation Respecting Environmental Impact Assessment and Review*, a project that involves the opening and operation of a metal mine with a production capacity of 2,000 t or more per day is subjected to the EIA procedure.**

The MDDELCC is in charge of the EIA process and relies on the Bureau d’audience publique sur l’environnement (“BAPE”) du Québec for public hearings. To date, the following steps have been completed or are still ongoing:

- **Project Notification:** In August 2016, a notice of intent was submitted to the MDDELCC including, in particular, the purpose, nature and scope of the Project. However, a TMF site was not identified at this time and therefore not presented in the notice. Ongoing discussions with the provincial and federal authorities will precise if this document needs to be modified and/or resubmitted.
- **Evaluation:** MDDELCC’s guidelines were received in August 2016 specifying the scope of the EIA that Falco must undertake. This project-specific directive shall also comply with Directive 019 which includes the guidelines for all mining projects. New or modified guidelines will be issued by MDDELCC’s following submission of a new or modified project notification by Falco.

- **Environmental Impact Assessment:** Falco is now conducting the environmental impact study, taking into account the directive issued by the MDDELCC. The summary of this study will be conducted after the completion of complementary documents described below.

The remaining steps of the process include:

- **Review:** Falco submits the EIA to the MDDELCC for review. Following this verification, the MDDELCC can address questions and comments in order to complement and clarify certain aspects of the EIA. Falco may have to answer one or more series of questions and comments. The MDDELCC then prepares an environmental analysis report that analyzes the Project in order to advise the Minister with respect to the environmental acceptability of the Project.
- **Public Participation:** The EIA is made public, allowing the population to request public hearings organized by the BAPE. Following the public hearings, the BAPE submit a report to the Minister.
- **Decision and Authorization:** Based on the conclusions of both the environmental report and the public hearings report, the Minister makes his recommendations to the government. The government then authorizes the Project (with or without modifications and conditions) by decree or rejects it. This authorization does not exempt the proponent from obtaining authorization(s) and permits that may be required by any law or regulation, including in relation to the EQA.

### Federal Procedure

The federal government requires an environmental and social impact assessments for projects covered under the *Canadian Environmental Assessment Act, 2012* (“CEAA” 2012). The CEAA 2012 applies to projects described in the *Regulations Designating Physical Activities*. The Horne 5 Project is subject to the federal environmental assessment (“EA”) process.

**According to Section 16(c) of the *Regulations Designating Physical Activities*, a project is subject to a federal EA procedure when it involves the construction, operation (and, eventually, the decommissioning and closure) of a new gold mine, other than a placer mine, with an ore production capacity of 600 t/day or more.**

Under CEAA 2012, an EA focuses on potential adverse environmental effects that are within federal jurisdiction, including:

- Fish and fish habitat;
- Other aquatic species;
- Migratory birds;
- Federal lands;

- Effects that cross provincial or international boundaries;
- Effects on Aboriginal peoples;
- Changes to the environment that are directly linked to federal decisions about a project.

The EA must consider a comprehensive set of factors that include cumulative effects, mitigation measures and comments received from the public. In order to determine whether such a federal EA is required, the proponent shall provide the CEAA with a project description if the latter is targeted by the regulation.

In August 2016, a project description was submitted to CEAA. In November 2016, CEAA issued a statement indicating that the impacts on components of federal jurisdiction were not believed to be significant, and that a federal EA would hence not be required.

However, in the meantime, new mining resources were added, and decision was made further to a selection process, to store and manage tailings on surface at the FQM site, about 11 km north-west from the Horne 5 Mining Complex. Since the planned TMF will encroach in natural water bodies most likely frequented by fish, an environmental assessment is required.

**A project which includes a proposal to use a natural, fish-frequented water body for the disposal of mine waste triggers a requirement for a federal EA under the CEAA 2012, where applicable.**

Moreover, using a natural water body frequented by fish for mine waste disposal requires an amendment to the MMER, which is a federal legislative action, to add the water body to Schedule 2 of the MMER. As a result, the project proponent must also:

- Prepare an assessment of alternatives for mine waste disposal for consideration (according to the federal guidelines);
- Prepare a fish habitat compensation plan for consideration as part of the EA;
- Participate in public and aboriginal consultations on the EA, including on possible amendments to the MMER.

Discussions must take place with CEAA to clarify if such EA is in fact required on the foregoing basis. Nevertheless, an assessment of alternatives must be completed, unless Falco can demonstrate that the waterbodies impacted do not contain fish. Field work was completed in 2017 to validate this aspect.



## 20.3.2 Laws and Regulations

Following release from the provincial and federal decree, the Project will require a number of approvals, permits and authorizations prior to initiation and throughout all stages of the Project. In addition, Falco will be required to comply with any other terms and conditions associated with the authorization issued by the provincial and federal regulators.

The most significant laws, regulations and directives among the legislation and government directives to be considered and respected are presented hereinafter. Some of the federal requirements will have to be validated against the federal decision about the EA need.

<b>Provincial Jurisdiction</b>
<b><u>Mining Act (c. M-13.1)</u></b>
<ul style="list-style-type: none"> <li>▪ <i>Regulation respecting mineral substances other than petroleum, natural gas and brine (M-13.1, r. 2)</i></li> <li>▪ <i>Guide de préparation du plan de réaménagement et de restauration des sites miniers au Québec (2016)</i></li> </ul>
<b><u>Environmental Quality Act (c. Q-2)</u></b>
<ul style="list-style-type: none"> <li>▪ <i>Regulation respecting the application of Section 32 of the Environment Quality Act (Q-2, r. 2)</i></li> <li>▪ <i>Regulation respecting the application of the Environment Quality Act (Q-2, r. 3)</i></li> <li>▪ <i>Clean Air Regulation (Q-2, r. 4.1)</i></li> <li>▪ <i>Regulation respecting industrial depollution attestations (Q-2, r. 5)</i></li> <li>▪ <i>Regulation respecting pits and quarries (Q-2, r. 7)</i></li> <li>▪ <i>Regulation respecting the declaration of water withdrawals (Q-2, r. 14)</i></li> <li>▪ <i>Regulation respecting mandatory reporting of certain emissions of contaminants into the atmosphere (Q-2, r. 15)</i></li> <li>▪ <i>Regulation respecting halocarbons (Q-2, r. 29)</i></li> <li>▪ <i>Regulation respecting hazardous materials (Q-2, r. 32)</i></li> <li>▪ <i>Protection Policy for Lakeshores, Riverbanks, Littoral Zones and Floodplains (Q-2, r. 35)</i></li> <li>▪ <i>Water Withdrawal and Protection Regulation (Q-2, r. 35.2)</i></li> <li>▪ <i>Land Protection and Rehabilitation Regulation (Q-2, r. 37)</i></li> <li>▪ <i>Regulation respecting the charges payable for the use of water (Q-2, r. 42.1)</i></li> <li>▪ <i>Directive 019 sur l'industrie minière (2012)</i></li> <li>▪ <i>Protection and Rehabilitation of Contaminated Sites Policy (1998)</i></li> </ul>
<b><u>Threatened or Vulnerable Species Act (c. E-12.01)</u></b>
<ul style="list-style-type: none"> <li>▪ <i>Regulation respecting threatened or vulnerable wildlife species and their habitats (E-12.01,r.2)</i></li> <li>▪ <i>Regulation respecting threatened or vulnerable plant species and their habitats (E-12.01,r.3)</i></li> </ul>
<b><u>Compensation Measures for the Carrying out of Projects Affecting Wetlands or Bodies of Water Act (M-11.4)</u></b>
<b><u>Watercourses Act (c. R-13)</u></b>
<ul style="list-style-type: none"> <li>▪ <i>Regulation respecting the water property in the domain of the State (R-13, r. 1)</i></li> </ul>

<b>Provincial Jurisdiction</b>
<b><u>Sustainable Forest Development Act (c. A-18.1)</u></b>
<ul style="list-style-type: none"> <li>▪ <i>Regulation respecting standards of forest management for forests in the domain of the State (A-18.1, r. 7)</i></li> </ul>
<i>Conservation and Development of Wildlife Act (c. C-61.1)</i>
<ul style="list-style-type: none"> <li>▪ <i>Regulation respecting wildlife habitats (C-61.1, r. 18)</i></li> </ul>
<i>Lands in the Domain of the State Act (c. T-8.1)</i>
<b><u>Building Act (c. B-1.1)</u></b>
<ul style="list-style-type: none"> <li>▪ Safety Code (B-1.1, r. 3)</li> <li>▪ Construction Code (B-1.1, r. 2)</li> </ul>
<b><u>Explosives Act (c. E-22)</u></b>
<ul style="list-style-type: none"> <li>▪ <i>Regulation under the Act respecting explosives (E-22, r. 1)</i></li> </ul>
<b><u>Cultural Heritage Act (c. P-9.002)</u></b>
<b><u>Occupational Health and Safety Act (c. S-2.1)</u></b>
<ul style="list-style-type: none"> <li>▪ <i>Regulation respecting occupational health and safety in mines (S-2.1, r. 14)</i></li> </ul>
<b><u>Highway Safety Code (c. C-24.2)</u></b>
<i>Transportation of Dangerous Substances Regulation (C-24.2, r. 43)</i>
<b>Federal Jurisdiction</b>
<b><u>Fisheries Act (R.S.C., 1985, c. F-14)</u></b>
<ul style="list-style-type: none"> <li>▪ <i>Metal Mining Effluent Regulations (SOR/2002-222)</i></li> <li>▪ <i>Guidelines for the Assessment of Alternatives for Mine Waste Disposal (2016)</i></li> </ul>
<b><u>Canadian Environmental Protection Act (S.C. 1999, c. 33)</u></b>
<ul style="list-style-type: none"> <li>▪ <i>PCB Regulations (SOR/2008-273)</i></li> <li>▪ <i>Environmental Emergency Regulations (SOR/2003-307)</i></li> <li>▪ <i>Federal Halocarbon Regulations (SOR/2003-289)</i></li> <li>▪ <i>National Pollutant Release Inventory</i></li> </ul>
<b><u>Species at Risk Act (S.C. 2002, c. 29)</u></b>
<b><u>Canada Wildlife Act (R.S.C., 1985, c. W-9)</u></b>
<ul style="list-style-type: none"> <li>▪ <i>Wildlife Area Regulations (C.R.C., c. 1609)</i></li> </ul>
<b><u>Migratory Birds Convention Act, 1994 (S.C. 1994, c. 22)</u></b>
<ul style="list-style-type: none"> <li>▪ <i>Migratory Birds Regulations (C.R.C., c. 1035)</i></li> </ul>

<b>Federal Jurisdiction</b>
<b><u>Nuclear Safety and Control Act (S.C. 1997, c. 9)</u></b>
<ul style="list-style-type: none"> <li>▪ General Nuclear Safety and Control Regulations (SOR/2000-202)</li> <li>▪ Nuclear Substances and Radiation Devices Regulations (SOR/2000-207)</li> </ul>
<b><u>Hazardous Products Act (R.S.C., 1985, c. H-3)</u></b>
<b><u>Explosives Act (R.S.C., 1985, c. E-17)</u></b>
<b><u>Transportation of Dangerous Goods Act (1992)</u></b>
<i>Transportation of Dangerous Goods Regulations (SOR/2001-286)</i>

### 20.3.3 Permitting Requirements

A non-exhaustive table of required permits and authorizations (Table 20-20) was carried out based on the known components of the Horne 5 Project and typical components of a mining project.

A certificate of authorization (“CoA”) under Sections 22 and 31.75 of the EQA was issued by the MDDELCC on March 1, 2016 for the dewatering of the two first levels (100 m below surface) of the Quemont No 2 shaft. Based on the new dewatering and sludge management strategy, a new application was filed in July 2017. Falco will also require a licence from the owner of all mining infrastructure in order to access, modify (as applicable), and use such infrastructure.

The Horne 5 Project will also require a depollution attestation. This attestation is required for an industrial establishment that has an ore mining capacity greater than 2,000,000 tpy or an ore or mine tailings processing capacity greater than 50,000 tpy.

Table 20-20: Preliminary and non-exhaustive list of required permits and authorization

Project Components	Request	Government Authority	Legal References	Application Status
<b>Provincial requirements</b>				
Mine dewatering	CoA	MDDELCC	Section 22 of the EQA	Submitted July 2017
Other deposit appraisal activities (i.e. bulk sample)	CoA	MDDELCC	Section 22 of the EQA	
Mining operation	CoA Mining lease Depollution Attestation	MDDELCC MERN MDDELCC	Section 22 of the EQA Section 100 of the Mining Act Section 31.10 of the EQA	
Location of mill, concentration plant and tailings site	Authorization Lease	MERN MERN	Section 240 and 241 of the Mining Act Section 47 of the Lands in the Domain of the State Act (if outside mining lease)	
Rehabilitation and restoration plan	Approval	MERN	Section 232.2 of the Mining Act	
Pits and quarries operation or crushing activities	CoA	MDDELCC	Section 22 of the EQA	
Equipment to prevent or reduce the issuance of contaminants into the atmosphere	Authorization	MDDELCC	Section 48 of the EQA	
Surface mineral substances extraction	Lease	MERN	Section 140 of the Mining Act	
Oil-water separators	CoA	MDDELCC	Section 22 of the EQA	
Effluent or water treatment facilities	CoA	MDDELCC	Section 22 of the EQA	
Connections between the waterworks and sewers conduits of a public system	Authorization	MDDELCC	Section 22 of the EQA	
Water intake	Authorization	MDDELCC	Section 31.75 of the EQA	Submitted July 2017 for mine dewatering

Project Components	Request	Government Authority	Legal References	Application Status
<b>Provincial requirements</b>				
Clearing	Permit	MFFP	Section 73 of the Sustainable Forest Development Act	
Infrastructure implantation on public land (if outside mining lease)	Lease	MERN	Section 47 of the Lands in the Domain of the State Act	
High-risk petroleum equipment	Permit	RBQ	Section 120 of the Safety Code	
Explosives possession, magazine and transportation	Permit	SQ	Section 2 of the Explosives Act	
Explosives magazines site	Lease	MERN	Section 47 of the Lands in the Domain of the State Act	
<b>Federal requirements</b>				
Explosives manufacturing plant and magazine	License	MNR	Section 7 of the Explosives Act	
Explosive transportation	Permit			
Use of radiation devices	Permit	CNSC	Section 3 of the Nuclear Substances and Radiation Devices Regulations	
Use of a natural water body frequented by fish as a "TIA"	Decree	Environment and Climate Change Canada	Section 5(1) and Division 4 of the Metal Mining Effluent Regulations	
Hazardous substances management set out in column 1 of Schedule 1	Notice and emergency plan	Environment and Climate Change Canada	Sections 3 and 4 of the Environmental Emergency Regulations	
<b>Municipal requirements</b>				
CoA submitted to the MDDELCC, Sections 22 or 32 of the EQA	Certificate of compliance	City of Rouyn-Noranda		
Building construction or modification Building repair, renovation or demolition	Construction permits	City of Rouyn-Noranda	Regulation No 2015-847	

In addition to the required permits and approvals listed in the table above, Falco will require one or more licences from the owner of all mining infrastructure prior to conducting any activities in order to access, modify (as applicable), and use such infrastructure.

## 20.4 Social Considerations

A community relations office is established near the Horne smelter, in the Vieux-Noranda neighbourhood. By choosing this location of high historical and cultural importance, Falco wanted to be easily accessible to the population, as well as being close to the community that might be impacted by the Horne 5 Project.

### 20.4.1 Consultation Activities

Since 2014, project presentations, consultations activities and discussions about potential collaboration projects were carried out with the following stakeholders.

**Table 20-21: List of the consultation activities carried out to date**

Stakeholders	Objective
Centre de formation professionnelle Quémont	Meeting about the Project development and the relocation of the training centre.
Lamothe, a Sintra Inc. division	Meeting about the Project development.
Les ateliers Manutex	Project presentation and discussions about a potential collaboration project.
École La Source	Meetings about the relocation of the Centre de formation professionnelle Quémont.
Commission scolaire de Rouyn-Noranda	Meetings about the relocation of the Centre de formation professionnelle Quémont.
Noranda Golf	Meeting about a possible land use agreement for the water line of the final effluent discharge point.
Ministère des Transports, de la Mobilité durable et de l'Électrification des transports	The Ministry is currently undertaking the construction of the 117 road bypass of Rouyn-Noranda city. The first meeting was about the possibility of integrating the water line of the final effluent discharge to the road and the requirements needed to satisfy the Ministry technical design. Further meetings also focused on the capacity of the current road network to support the traffic generated by the Project.
MDDELCC	Project presentation, meetings about its development and discussions on regional training.
Minister for Mines and responsible for the Abitibi-Témiscamingue region	Project presentation.
Minister of Energy and Natural Resources	Project presentation.
City of Rouyn-Noranda and its Mine Consultative Committee	Project presentation and meetings about its development and zoning modification request.
Chambre de commerce de Rouyn-Noranda	Project presentation and meetings about its development.
Centre local de développement	Project presentation.
Centre local d'emploi	Project presentation and labor requirements.

Stakeholders	Objective
Vieux-Noranda Committee	Project presentation. People are receptive and some technical and economic questions are asked. The Committee mentioned that contributions in the preservation of the old heritage and Noranda mining world (monetary aid, conservation and architectural design, participation in events, etc.) would be appreciated.
Conseil régional de l'environnement de l'Abitibi-Témiscamingue	Project presentation and meetings about its development.
Club de motoneige de Rouyn-Noranda	The organization sought the help of Falco for the creation of new trails on its site. The company is open to helping the organization and further discussions on this are coming.

No surveys or meetings were held for Rouyn-Noranda's citizens, nor at a regional level. Nevertheless, the Horne 5 Project has been made widely public by the local news. Up until now, the Project generated positive reactions and no complaints were addressed to the Falco community relations office.

Information and consultation activities with stakeholders will continue throughout the development phase of the Project, as well as during the construction and the operation of the mine. A wider audience will gradually be invited to participate.

#### 20.4.2 Concerns Gathered through Consultation Activities

The main concerns that were gathered through consultation activities were:

- Capacity of the city to host the Project in terms of municipal infrastructure (water, sewers, fire service) and housing;
- Enhancement of the presence of local businesses in the business opportunities created by the Project;
- Training of the local workforce to ensure that they qualify for the jobs offered by the Project.

#### 20.4.3 Social Components and Related Requirements

The information presented in this section was taken from the Land Use and Development Plan ("LUDP") of the city of Rouyn-Noranda (Ville de Rouyn-Noranda, 2015a). The different components are illustrated in Figure 20-22 for the Horne 5 Mining Complex and Figure 20-23 for the TMF site.

The territory of the city of Rouyn-Noranda has a superficies of 6,480 km<sup>2</sup> and counts nearly 41,000 inhabitants. It is the 5th largest territory and the 25th most populous municipality of Québec. Natural resource exploitation still has a big role to play in the socioeconomic development of the municipality. Mining activities provide 8.5% of the jobs (Ville de Rouyn-Noranda, 2015a).



#### 20.4.3.1 Land Planning and Development and Land Use

The city of Rouyn-Noranda has the double status of municipality and regional county municipality. A regional county municipality must have, at all times, a LUDP applicable to its whole territory. This Report establishes the main guidelines for regional planning, which is then detailed in the planning program and the planning regulations as required by the *Land Use Planning and Development Act*.

##### Horne 5 Mining Complex

According to the LUDP of the city of Rouyn-Noranda, the Horne 5 mine project is located within the urban industrial area, in the "Noranda-Nord" industrial park (Ville de Rouyn-Noranda, 2015a). Mining activities are consistent with usage allowed for the territory assignment but under the following restriction: the city must be informed prior to the implementation of any proposed mine development (Ville de Rouyn-Noranda, 2015b).

The nearest residents from the mine site are less than 1 km to north-west, along des Lilas Street and about 1 km to south in Noranda sector, near the railroad. The Noranda golf course is adjacent to the mine site, located on its north-east side. Refer to Figure 20-22 for more details.

##### TMF Site

According to the LUDP of the city of Rouyn-Noranda, the TMF and pipelines route are located in a resource exploitation zone in their northern end and in an urban zone in their southern part. Mining activities are consistent with the usages allowed for this territory.

Three recreational leases for temporary shelters are found around the TMF on its northern and south-western sides. Two of them are located near Vauze and Waite Lakes. Additionally, about 12 residences are found along rang Jason, the nearest being about 2 km south-east of the TMF site.

The projected routing of the pipelines run along or cross a provincial snowmobile trail (Trans-Québec no 93) and a quad trail (Trans-Québec no 01). The pipelines route will also follow an electrical transmission line (120 kV) and follow or cross forested trails and watercourses.

Numerous water intakes are located along the regional route 101, near the Embo golf course and the D'Alembert sector of Rouyn-Noranda. The Norbec site and a large proportion of the projected pipelines are located in the «zone 08-065 du Bassin versant—lacs Dufault et Duprat» of the Plan d'affectation du territoire public, where the preferred governmental intent is to preserve water quality and use this territory for water intake. This vocation of use is identified as a priority. As mentioned in previously, Dufault Lake serves as a source of drinking water for the city of Rouyn-Noranda. As for the Duprat Lake, it was identified as the alternative source of drinking water for the city. Refer to Figure 20-23.



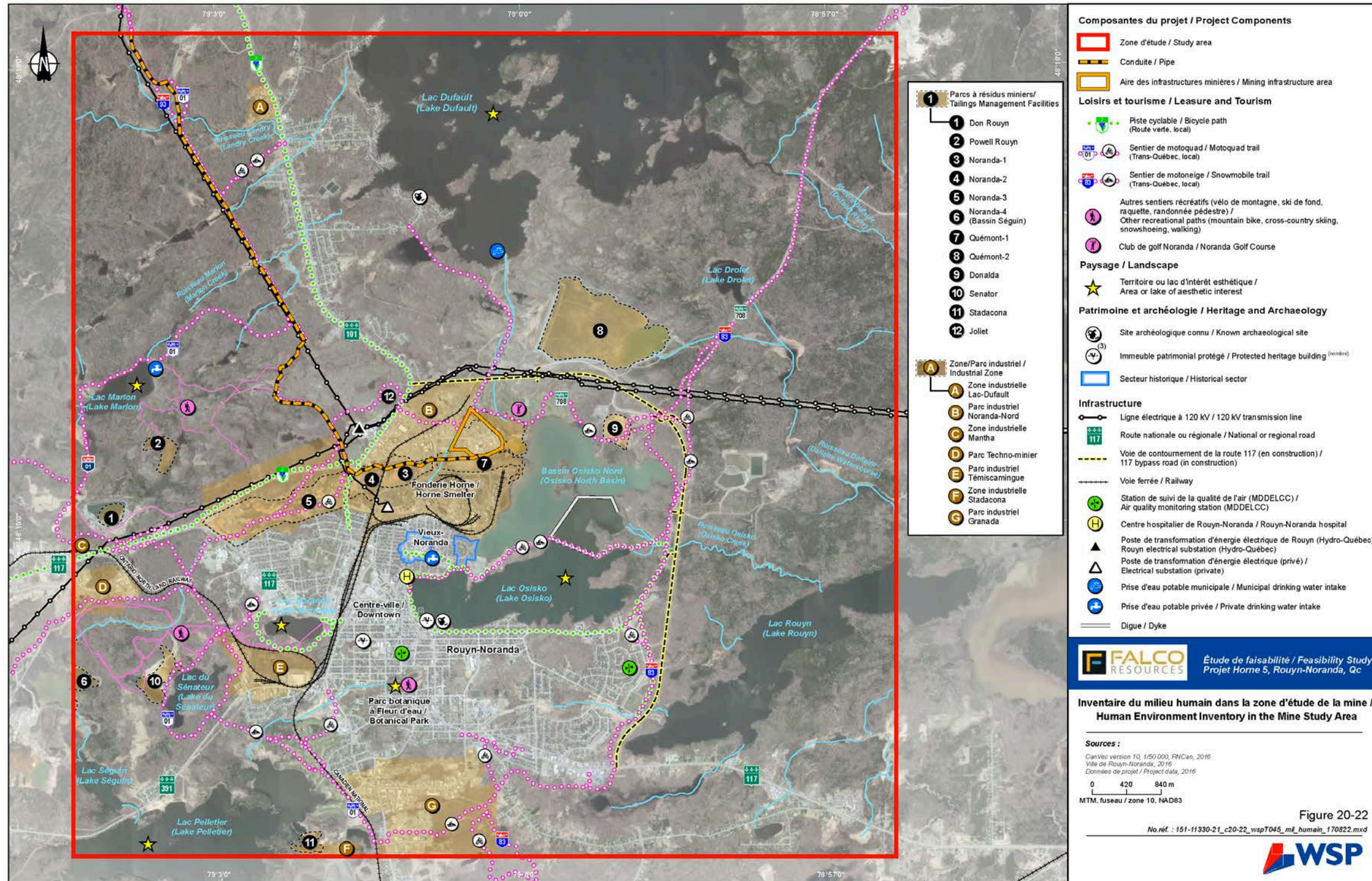

Figure 20-22: Social Components and Study Areas – Horne 5 Mining Complex



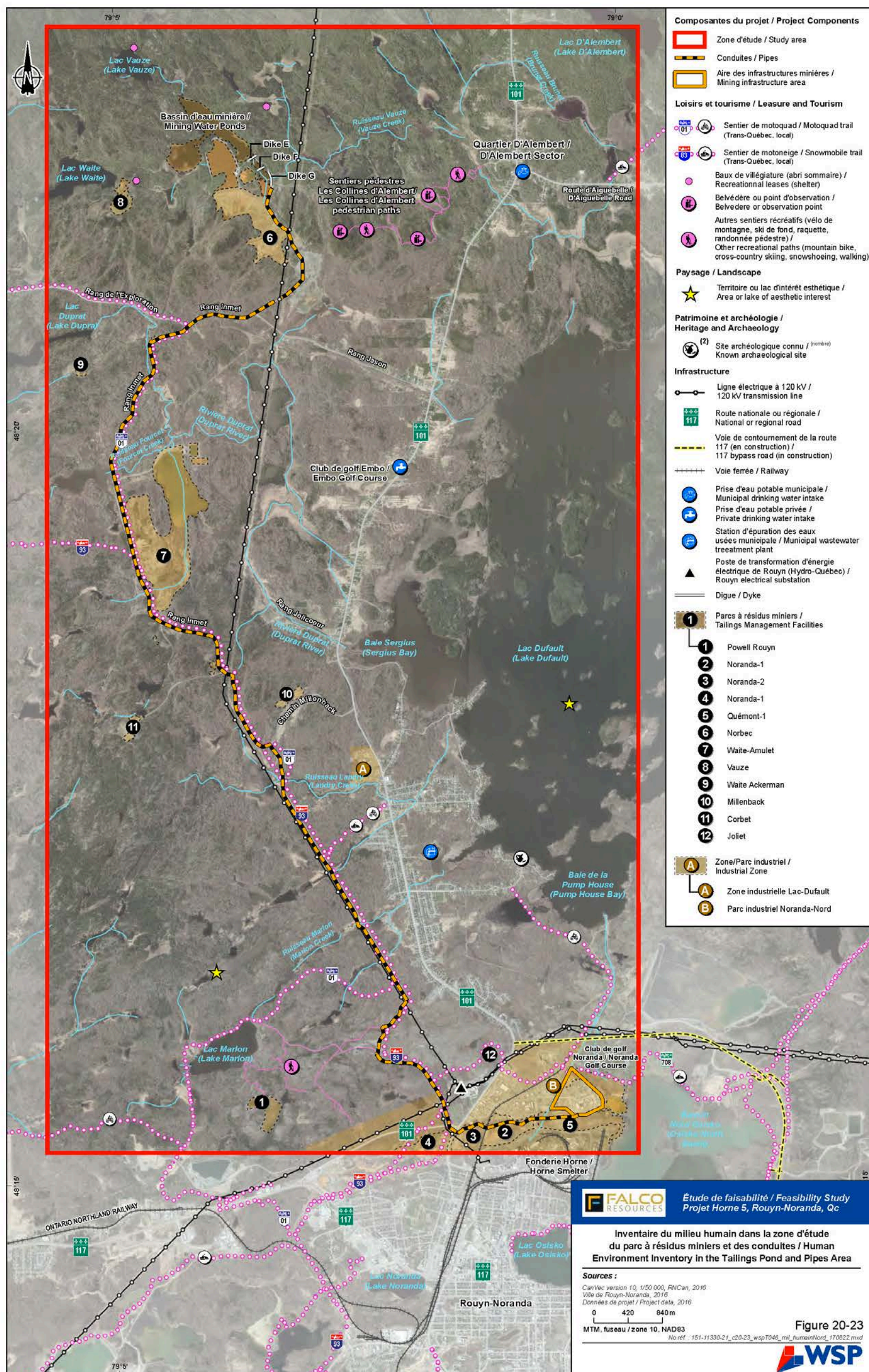

Figure 20-23: Social Components and Study Areas – TMF Site



In this area where the possible uses of territory and resources were numerous, the objective is to ensure the quality of the water used for human consumption by allowing only the uses of territory and resources which do not have the effect of degrading the quality criteria (pathogenic organisms, chemicals, taste, smell and appearance) and adapt management practices accordingly. There are, therefore, significant restrictions on activities in this area (interventions and infrastructure) that could degrade the quality of drinking water for human consumption. In addition to Dufault Lake mentioned above, this area includes Waite, Vauze and Duprat Lakes and the waterbody northwest of the actual Norbec TMF.

#### 20.4.3.2 Landscape Components

##### Horne 5 Mining Complex

In its regional county municipality plan, the city has identified aesthetic landmarks, territories and lakes. The Parc botanique à Fleur d'eau is located 3.1 km to the southwest of the Horne 5 Project and is identified as an aesthetic site. A number of lakes of aesthetic interest are located near the study area. The closest are the Osisko North Basin immediately to the east, the Osisko Lake 1.5 km to the south and the Dufault Lake 2.1 km to the north.

A 3D simulation of the Horne 5 Project has been prepared in 2017. Additionally, it is planned in the EIA in preparation to evaluate the impacts of the Project on the landscape units nearby and to provide photo-simulation showing how the Project will insert in the existing landscape and impact the sensitive point-of-views.

Additionally, the impact of the Project on the visual night landscape (intrusive light pollution) will be assessed from measurement of actual lighting conditions coming from existing infrastructure in the receiving environment and measurements of sky brightness. The proposed lightning conditions of the future buildings and operations will be modelled and their effect on the landscape will be evaluated for sensible point-of-views (recreational areas and neighbouring stakeholders).

##### TMF Site

In its regional county municipality plan, Rouyn-Noranda City has not identified aesthetic landmarks or territories along the pipes route or near the tailings facility. Nevertheless, a municipal recreational park named Les Collines d'Alembert, located east of the projected TMF site in the D'Alembert sector, owns three belvederes, with one of them oriented toward the Norbec site.

As for the Horne 5 Mining Complex, the presence of the TMF site in its insertion landscape (day and night conditions) will be evaluated using photo-simulations and modelling from the sensible point-of-views.

### 20.4.3.3 Archaeology and Heritage

#### Horne 5 Mining Complex

There are two historical sectors in the study area: Vieux-Noranda neighbourhood and the Dirigeants neighbourhood, both located directly south of the Horne smelter. Most of the protected and unprotected sites of historic and heritage interest are located in these neighbourhoods. Four sites have a protected status: Saint-Georges Church, Maison-Dumulon heritage site, Dumulon House, Jos-Dumulon General Store. The last three sites are found at the same location.

According to the regional county municipality plan, three archaeological sites are located in the study area, as shown in Figure 20-22. Two are unknown prehistoric Native American and the third, located west near the Maison-Dumulon heritage site, have a protected status.

Since most of the infrastructure at the Horne 5 Mining Complex is planned to be established on already disturbed areas, and that the archeological potential is low (Corporation Archéo-08, 2017), there is no need to carry out an archaeological investigation. Nevertheless, if during the project development an archaeological discovery is made, the Culture and Communications ministry must be informed of it without delay, as required by the *Cultural and Heritage Act*.

#### TMF Site

The study area of the TMF site does not include any historical sectors, nor archaeological known site. In its current state, the development of the tailings pond will require excavation work in undisturbed areas. Moreover, some of the watercourses, as well as former mine sites along the pipelines route, might possess some archeological potential (Corporation Archéo-08, 2017). Therefore, it might be required to carry out an archaeological investigation. Nevertheless, if an archaeological discovery is made during the project development, the Culture and Communications ministry must be informed without delay, as required by the *Cultural and Heritage Act*.

### 20.4.3.4 First Nations

Rouyn-Noranda is part of an area over which different Algonquin First Nations communities assert Aboriginal rights. Since there are different Tribal Councils involved in these claims, the question of aboriginal rights is an issue that is carried out by several instances.

In February 2017, an agreement was made public by the Québec Government and the Abitibiwinni First Nation regarding consultation and accommodation with the mining sector. The objective of this agreement was to clarify the consultation process and determine a territory of application. The Horne 5 Project is located in a zone were Abitibiwinni First Nation territory overlap with other Algonquins nations.

Seven communities were identified in regard to the project location. These communities are located within a radius of 150 km around Rouyn-Noranda. Two of them are in Ontario, the others are in Québec. The seven communities are represented by three different Tribal Councils<sup>2</sup>:

Algonquin Anishinabeg Nation Tribal Council

- Kitcisakik (Québec)
- Lac-Simon (Québec)
- Winneway (Québec)
- Pikogan (Québec)
- Wahgoshig (Ontario)<sup>3</sup>

Wabun Tribal Council

- Matachewan (Ontario)

Algonquin Nation Tribal Council

- Timiskaming First Nation (Québec)

Among the various agreements reached between the provincial government and Algonquin communities, one was concluded in December 2016 with the Abitibiwinni Nation regarding consultation and accommodation with the mining sector. The objective of this agreement was to clarify the consultation process and determine a territory of application.

Initial approaches with the *Secrétariat aux affaires autochtones du Québec*, as well as with the Indigenous and Northern Affairs Canada have been initiated to identify potential consultation requirements.

## 20.5 Mine Closure Requirements

In accordance with the *Mining Act* of Québec, a closure and restoration plan must be submitted to the MERN for the mining lease to be issued. The main objective in restoring a mine site is to return the site to an acceptable condition, ensuring that the site is safe and the surrounding environment is protected. It is important to note that the Horne 5 Mining Complex has already been impacted by industrial activities and the closure plan will focus the rehabilitation of land and areas affected essentially by mining activities (i.e., pads, buildings, water ponds, surface drainage

<sup>2</sup> The Tribal councils also serve other communities that are not listed here because of their locations.

<sup>3</sup> Wahgoshig is also member of the Wabun Tribal Council in Ontario.

patterns, etc.). The closure plan must address the following items: securing the mine site, dismantling of infrastructure, reclamation of waste rock and ore disposal areas, an emergency plan and post-closure environmental monitoring.

The closure cost estimate for the Horne 5 Project is based essentially on the dismantling of the mine's buildings at the Horne 5 Mining Complex and the restoration of the TMF at the Norbec site. Falco intends to dismantle all buildings that will have served its mining operations. Although, given the site's proximity to the city and the existence of very little infrastructure of this type in Rouyn-Noranda, it is reasonable to think that these buildings could be reused or modified for other uses. However, the Horne 5 Mining Complex being located partially on contaminated material (old tailings and waste rock), this could represent a concern for environmental liabilities and the restoration objectives at mine closure. Discussion with the MERN and MDDELCC should be initiated in order to agree on a restoration and rehabilitation strategy.

Regarding the TMF at the Norbec site, the PCT Cell will be covered by a liner system and the PFT Cell will be covered with a multilayer.

In 2013, the *Mining Act* of Québec was updated, and additional measures were included to ensure that the restoration of mining sites upon closure is enforced. The total amount of the restoration costs is now required as a financial guarantee. The payment shall be provided in three installments constituting 50%, 25% and 25% of the total restoration costs. The first payment (half the cost) shall be provided within 90 days of receiving the approval of the restoration plan. The second and third installments (25%) are due on the anniversary date of the restoration plan approval. In summary, Falco must provide a financial guarantee which amount corresponds to the total anticipated cost of completing all the work within the first three years. The estimated restoration cost for the Horne 5 Mining Complex and the TMF are presented in the Table 21-27 of the Chapter 21. As required by the MERN, this cost estimate includes the cost of site restoration, the post-closure monitoring as well as engineering costs (30%) and a contingency of 15%.

## 20.6 Anticipated Environmental Issues

All potential impacts of the Project will be assessed for the EIA that should be conducted by Falco. However, given the Project components described in previous sections, and based on available data on the environment, a preliminary list of the main anticipated issues or impacts have been determined for the construction, operation and also for the closure and rehabilitation activities. They are presented in the table hereinafter.

The optimization of the Project design will be aimed at reducing the potential impact of environmental issues.



Table 20-22: Mine site and related infrastructure anticipated issues or impacts

Environmental and Social Components	Anticipated Issues or Impacts	Possible Mitigation Measures
Hydrology	<p>Changes in the local flow regime during both the construction and operation phases</p> <p>Changes in the receiving environment flow regime during dewatering and operation phases.</p> <p>Water intake from Lake Rouyn</p>	<p>Temporarily disturbed flows will be progressively re-established after the work to avoid any sudden flow changes</p> <p>The flow at the final discharge point will be kept at an appropriate level to ensure that it doesn't compromise the integrity of the waterbody.</p> <p>The water intake will be kept at an appropriate level to ensure that it doesn't compromise the integrity of the waterbody</p>
Hydrogeology	<p>Changes in the local groundwater flow regime during construction and operation phases</p>	<p>During construction, and as needed during the operation, a network of monitoring wells will be established around the new infrastructure, to check for changes in water levels and quality</p>
Surface and Groundwater Quality	<p>Risk of groundwater contamination through accidental spillage of oils, hydrocarbons or any other hazardous substances – during all mine life</p> <p>Discharge of fine particles and woody debris into the water during construction, operation and rehabilitation phases</p> <p>Potential groundwater quality issues after closure due to the underground deposition of tailings</p>	<p>The number of machinery fuelling sites will be minimized to reduce the number of at-risk sites</p> <p>Any eventual leaks due to faulty valves or human error will be reported to the environmental overseer and, depending on the case, to maintenance for repair</p> <p>Soaked surface soil will be immediately dug up and disposed of as per regulations</p> <p>Post-closure environmental monitoring</p>
Soil and Sediment Quality	<p>Risk of soil contamination through the accidental spillage of oils, hydrocarbons or any other dangerous liquids – during all mine life</p>	<p>The number of machinery fueling sites will be minimized to reduce the number of at-risk sites</p> <p>Any eventual leaks due to faulty valves or human error will be reported to the environmental overseer and, depending on the case, to maintenance for repair</p> <p>Soaked surface soil will be immediately dug up and disposed of as per regulations</p>
Atmospheric Environment	<p>Emission of dust, GHG and other contaminants into the ambient air generated by the vehicles during construction, operation and closure phases.</p> <p>Effect on air quality due to mining and concentrating operations and transportation of concentrate from the site.</p> <p>Emission of dust due to wind erosion of piles.</p>	<p>Use dust suppressor.</p> <p>The machinery used shall meet EC's emission standards for on-road and off-road vehicles.</p> <p>Minimize machinery idling time.</p> <p>Implement a dust management plan.</p>

Environmental and Social Components	Anticipated Issues or Impacts	Possible Mitigation Measures
Noise and Vibrations	Effect on ambient sound due to construction activity, mining and concentrating operations and transportation of concentrate from the site. Effect on local vibration level from blasting.	Minimize machinery idling time. Noise monitoring program. Vibration monitoring program.
Vegetation and Wetlands	Loss of area covered by natural vegetation for the pipelines and TMF site.	Minimize the new infrastructure's total footprint.
Wildlife and their Habitats	Loss of habitat during construction phase. Disturbance of wildlife during operation phase.	The construction work will be conducted if possible outside the breeding season of the main species present at this latitude.
Fish Habitat	Fish habitat loss due to the TMF footprint. Fish habitat alteration due to the mine's final effluent. Fish habitat alteration during construction.	Minimize as much as possible encroachment in lakes and watercourses. Reuse of process water. Rigorous water management. Rigorous erosion and sediment control management.
Species at Risk	Unknown at this stage - lack of data	Reduce the Project's footprint
Economy, Employment and Business	Economic spinoffs for Rouyn-Noranda and regional suppliers Job creation	Local Purchasing Policy Local Employment Policy
Land Use	No land use changes on the mining complex and TMF Pipelines to be installed on private and public lands	At the closure of the mine, the site will be rehabilitated to meet with industrial uses. Restoration of disturbed soil and vegetation adapted to the surroundings.
Landscape	Changes to landscape units and associated visual fields	During the design phase, configuration of the infrastructure and the TMF as much as possible in harmony with the natural topography of the surrounding relief.
Archeology and Heritage	Low to moderate potential along the pipelines route.	Initiate an archeological inspection. If, during excavation works, vestiges of historical or archaeological interest were to be discovered, the work site overseer would be immediately informed and provisions made for the site's protection.
First Nations	Unknown at this stage - lack of data	Consultation
Third Party Rights	In order to proceed with the activities described in this Report, Falco must obtain, in a timely manner, third party approvals, licenses, rights of way and surface rights (as described above in Chapters 16 and 18); there can be no	Prepare an extensive list of activities describing the access right, infrastructures and required modifications which will be necessary to continue to develop and proceed with construction of the Horne 5 Project; submit this list as soon as possible to the relevant third parties in order to

Environmental and Social Components	Anticipated Issues or Impacts	Possible Mitigation Measures
	<p>assurance that any such license, rights of way or surface rights will be granted, or if granted will be on terms acceptable to Falco and in a timely manner.</p> <p>Failure by Falco to obtain such third party approvals, licenses, rights of way and surface rights in a timely manner and on terms acceptable to it could have a negative impact on the development and construction of the Horne 5 Project and on the cost related thereto.</p> <p>Furthermore, Falco notes that the timeline of activities described in this Report, and the estimated timing proposed for commencement and completion of such activities, is subject at all times to matters that are not within the exclusive control of Falco. These factors include the ability to obtain, and to obtain on terms acceptable to Falco, financing, governmental and other third party approvals, licenses, rights of way and surface rights (as described above). Failure by Falco to obtain in a timely manner and on terms acceptable to Falco, financing, governmental and other third party approvals, licenses, rights of way and surface rights could have a negative impact on the development and construction of the Horne 5 Project and on the cost related thereto.</p>	<p>initiate the negotiation that should lead to either the acquisition of such rights or to the grants of the required license and rights of way.</p> <p>As part of such negotiation, Falco shall seek appropriate financial support to provide such third parties with adequate indemnity as may be required.</p> <p>Falco can begin work that does not required third party approval in order to keep with its timeline for the Project.</p>

## 21. CAPITAL AND OPERATING COSTS

The capital and operating cost estimates presented in this FS for the Horne 5 Project are based on the construction of an underground mine and process plant with an average throughput of 15,500 tpd over the LOM, and located in an industrial urban setting.

All capital and operating cost estimates cited in this Report are referenced in Canadian dollars. Acquisition of non-domestic capital items or operating consumables assumes the exchange rates discussed in Section 21.1.2.3 where applicable.

### 21.1 Capital Costs

#### 21.1.1 Summary

The total preproduction capital cost for the Horne 5 Project is estimated to be \$1,062.1M. This estimate includes the addition of certain contingencies and indirect costs. The cumulative life of mine capital expenditure (preproduction and sustaining capital) is estimated to be \$1,597.5M.

Table 21-1: Project preproduction capital cost summary

WBS	Cost Area	Preproduction Capital Cost (\$M)	Sustaining Capital Cost (\$M)	Total Cost (\$M)
000	General Administration	47.2		47.2
200	Underground Mine	256.9	325.1	582.0
300	Mine Surface Facilities	81.8	4.7	86.5
400	Electrical & Communication	18.3	2.3	20.5
500	Site Infrastructure	13.2	-	13.2
600	Processing	379.4	13.0	392.5
700	Community Infrastructure and Relocation	36.1	-	36.1
800	Tailings and Water Management	68.5	190.3	258.7
900	Indirects	85.8	-	85.8
999	Contingency	75.0	-	75.0
	<b>Total</b>	<b>1,062.1</b>	<b>535.4</b>	<b>1,597.5</b>
	Less Outlays to August 31, 2017	(34.3)	-	(34.3)
	Site Reclamation and Closure	-	87.2	87.2
	Salvage Value	-	(45.0)	(45.0)
	<b>Total – Forecast to Spend</b>	<b>1,027.8</b>	<b>577.5</b>	<b>1,605.4</b>

### 21.1.2 Scope and Structure of Capital Cost Estimate

The capital cost estimate pertaining to this FS is meant to form the basis for an overall project budget authorization and funding, and as such, forms the “Control Estimate” against which, subsequent phases of the Project will be compared to and monitored. It meets AACE Class 3. The accuracy of the capital cost estimate developed in this FS is qualified as -10%/+15%. Generally, 10% of engineering is performed to date, while the level of project definition is 35%.

The capital cost estimate abides by the following criteria:

- Based on measurable degree of engineering completion;
- Reflects general accepted practices in the cost engineering profession;
- Assumes contracts will be awarded to reputable contractors on a cost reimbursable basis;
- Labour costs are based on current Québec Industrial construction collective bargaining agreement;
- Preproduction capital costs are expressed in constant Q2 2017 Canadian dollars.

The Project schedule, from detail engineering to start-up, was also used in the estimate preparation; refer to Chapter 24 for the execution plan and schedule. The construction phase began on September 1, 2017. Any construction before this date is considered “Early Works” (work plan capital) and is not included in the capital cost estimate. Payments made on mechanical and electrical equipment, as well as detailed engineering costs previous to this date were included in the capital cost estimate but were excluded from the financial model. The cost estimate was divided into the following elements:

- Preproduction Capital costs:
  - Direct costs (WBS 200 to 800): costs for productive works and permanent infrastructure. Includes productive infrastructure, services and equipment required for the extractive process;
  - Indirect costs (WBS 900): costs needed to support the construction of the facilities included in the direct costs. Includes engineering, procurement and construction management (“EPCM”) services, EPCM temporary facilities (infrastructure) and construction management, capital spare parts, freight and logistics;
  - Owner’s costs (WBS 000 General Administration): costs associated with the Horne 5 site personnel, management, support infrastructure, safety and environmental, community relations, administration and finance, human resources, training and others;
  - Contingency (WBS 999): includes variations in quantities, differences between estimated and actual equipment and material prices, labour costs and site-specific conditions. Also accounts for variation resulting from uncertainties that are clarified during detail engineering, when basic engineering designs and specifications are finalized.

- Sustaining Capital Costs:
  - Capital expenditures after the start of operations include costs for the tailings management facility initial construction and continuing development, the surface tailings and reclaim water pipelines, Phase 2 mine ramp and ore/waste pass extensions, Quemont No. 2 shaft re-sinking and associated underground infrastructure, equipment replacement, and closure costs. These costs are included in the financial analysis in Chapter 22 in the year in which they are incurred. Capital costs of Q3 2021 and after are classified as sustaining capital.

#### 21.1.2.1 Work Breakdown Structure (WBS) and Estimate Responsibilities

The capital cost estimate was developed in accordance with Falco’s work breakdown structure (“WBS”) with the estimate responsibilities summarized in Table 21-2:

Table 21-2: Estimate responsibilities by WBS

WBS Area	WBS Description	Responsible Entity
000	General Administration (Owner’s cost)	Falco, InnovExplo
200	Underground Mine	InnovExplo, Golder, WSP
300	Mine Surface Facilities	WSP, InnovExplo
400	Electrical & Communication	BBA
500	Site Infrastructure	SNC-Lavalin, RIVVAL
600	Processing	BBA, WSP
700	Community Infrastructure and Relocation	Falco
800	Tailings and Water Management	Golder, Falco
900	Indirects	Falco
999	Contingency	Falco

#### 21.1.2.2 Exchange Rate Assumptions

This estimate is based on costs obtained during the first half of 2017 and excludes any price escalation. The following table provides the exchange rate assumptions used:

Table 21-3: Exchange rate assumptions

Base Currency	Price Currency	Exchange Rate
CAD	USD	\$0.78
CAD	EUR	€0.699
CAD	AUD	\$1.0103

### 21.1.2.3 Exclusions

The following items were excluded from the capital cost estimate:

- Certain land acquisitions;
- Permitting, licensing, and financing costs;
- Project development costs incurred to date, including studies and early works;
- Taxes (included in the financial model);
- Geotechnical anomalies (must be considered as risk);
- Pre-operations testing and start-up beyond C4 certificate;
- Operating costs;
- Changes to design criteria;
- Work stoppages;
- Scope changes or an accelerated schedule;
- Hydrological, environmental or hazardous waste issues;
- The cost of the mobile fleet rebuilds and replacements to support process plant operations (these are included in the operating costs);
- Costs relating to certain agreements with third parties.

### 21.1.2.4 Construction Labour

All estimated costs for construction labour are based on 8 hours per day, 5 days per week, for a total of 40 hours worked per week. There is no allowance for evening shifts. Three different rate tables are applied in the estimate. The heavy industrial construction work rates are applied for areas 400 and 600. The light industrial construction work rates are applied to areas 300 and 500. Finally, an open shop average rate is applied for the underground mine construction activities (area 200).



### Heavy and Light Industrial

The crew rates for heavy industrial construction and light industrial construction are built from three components as follows:

1. The direct costs are derived from the Québec construction collective agreement for the industrial sector applicable for the period from 2014 to 2017. The crew rates include a mix of skilled, semi-skilled and unskilled labours for each trade, as well as the fringe benefits on top of the gross wages. Supervision by the foremen and surveyors is built into the direct costs; the rates are calculated as per the annex B2 (Heavy Industrial) of the Québec construction collective agreement.
2. The indirect costs consist of items such as small tools, consumables, supervision by the general foremen, contractor management team, contractor on-site temporary construction facilities, mobilization/demobilization, as well as contractor overhead and profit. They also include the costs related to the transportation of the employees to and from their residence to the construction site, as well as room and board; transportation was calculated using a 90 km rate for 25% of all workers, room and board was calculated for 25% of all workers except the civil discipline workers which were assumed to be all available locally.
3. Contractor construction equipment, required per trade to accomplish their tasks, cost estimates are based on the tariff proposed by “*La Direction Générale des Acquisitions du Centre de Services Partagés du Québec*”, detailed inside edition dated April 1, 2017. The fuel (diesel) associated with the construction equipment in the present estimate is estimated at 1.00 \$/litre. All lifting equipment (Labour & Material) were not calculated in the rates but added to the direct costs (for the case of crane allowance) and the indirect costs (for the case of mobile equipment) calculated by Falco.

Table 21-4: Heavy industrial labour rates (\$/hour)

Typical Crew	Labour Rate		Equipment Rate (\$/h)	Crew Rate Total (\$/h)
	Direct (\$/h)	Indirect (\$/h)		
Civil Works=Site Preparation / Clearing / Access Roads	65.09	21.79	37.14	124.00
Civil Works=Hand Excavation / Underpinning	63.19	23.50	7.29	94.00
Civil Works=Rock Excavation / Blasting + Hauling	68.55	24.82	72.37	165.75
Civil Works=Piling + Shoring	66.24	23.14	46.07	135.45
Heavy Civil Works=Excavation / Backfill + Compaction	67.24	22.33	77.60	167.15
Rate Standard Civil Works=Excavation / Backfill + Compaction	66.60	22.19	60.98	149.75
Light Civil Works=Excavation / Backfill + Compaction	66.29	22.12	51.02	139.45
Concrete Works=Formworks + Reinforcement + Concrete	67.42	31.83	7.94	107.20

Typical Crew	Labour Rate		Equipment Rate (\$/h)	Crew Rate Total (\$/h)
	Direct (\$/h)	Indirect (\$/h)		
Structural Works=Unload + Shake out / Erect + Plumb	71.47	34.05	7.99	113.50
Heavy Architectural Works=Masonry / Roofing / Cladding	67.01	31.75	2.48	101.25
Light Architectural Works=Gypsum Board / Flooring / Painting	66.84	31.72	1.09	99.65
Heavy Mechanical Works	71.24	37.46	4.86	113.55
Light Mechanical Works	69.26	36.95	2.93	109.15
Piping	68.10	36.60	3.27	107.95
Piping (Insulation)	67.13	32.08	0.87	100.10
Electrical	69.71	36.95	0.82	107.50
Electrical Power Transmission Lines	64.62	35.86	75.32	175.80
Automation and Telecommunications	70.37	37.32	0.67	108.35

Table 21-5: Light industrial labour rates (\$/hour)

Typical Crew	Labour Rate		Equipment Rate (\$/h)	Crew Rate Total (\$/h)
	Direct (\$/h)	Indirect (\$/h)		
Civil Works=Site Preparation / Clearing / Access Roads	62.88	18.77	36.54	118.20
Civil Works=Hand Excavation / Underpinning	60.88	21.21	6.82	88.90
Civil Works=Rock Excavation / Blasting + Hauling	66.95	22.54	71.43	160.90
Civil Works=Piling + Shoring	64.57	20.96	45.44	130.95
Heavy Civil Works=Excavation / Backfill + Compaction	65.20	20.02	77.09	162.30
Standard Civil Works=Excavation / Backfill + Compaction	64.74	19.91	60.46	145.10
Light Civil Works=Excavation / Backfill + Compaction	64.39	19.82	50.51	134.70
Concrete Works=Formworks + Reinforcement + Concrete	64.13	23.60	7.36	95.10
Structural Works=Unload + Shake out / Erect + Plumb	67.95	25.66	7.33	100.95
Heavy Architectural Works=Masonry / Roofing / Cladding	64.04	23.58	1.82	89.45
Light Architectural Works=Gypsum Board / Flooring / Painting	64.04	23.58	0.43	88.05
Heavy Mechanical Works	67.28	28.89	4.03	100.20
Light Mechanical Works	65.67	28.53	2.16	96.35
Piping	64.32	28.23	2.61	95.15
Piping (Insulation)	63.33	23.50	0.25	87.10
Electrical	65.69	28.54	0.16	94.40
Electrical Power Transmission Lines	64.62	28.30	75.29	168.20
Automation and Telecommunications	66.33	28.68	0.05	95.05

### Underground Construction Labour

The open shop crew rate for underground work is estimated to be on average \$80/h. It was calculated from an average of rates obtained from four contractors. This rate includes the direct labour cost of wages and fringe benefits, an additional 15% for contractor supervision (including health and safety meetings) and finally 15% for administration and profit.

#### 21.1.2.5 Productivity

Labour productivity is one of the greatest risk factors and uncertainties in cost and scheduling. The two most important measures of labour productivity are:

1. The effectiveness with which labour is used in the construction process;
2. The relative efficiency of labour, doing what it is required, at a given time and place.

Important factors affecting productivity on a construction site (such as site location, labour turnover, health and safety consideration, weather conditions, supervision, etc.) were considered to calculate the labour productivity loss factors shown in Table 21-6.

Table 21-6: Labour productivity factors

Trade	Productivity Loss Factor
Earthworks	1.184
Concrete Works	1.208
Metal Works	1.260
Architectural	1.228
Mechanical Process	1.259
Piping	1.263
Electrical	1.263
Automation/Telecom	1.263

The productivity factors are applied on installation costs evaluated from first principles for areas 300, 400, 500, and 600.

Winter conditions are expected between the months of October and April. This is incorporated within the aforementioned productivity factors.

### 21.1.3 Preproduction Capital Costs

The Project preproduction capital cost summary is outlined in Table 21-7 and shown as a pie chart in Figure 21-1. The capital cost breakdown descriptions are outlined in the following sections.

Table 21-7: Project preproduction capital cost summary

Area	Cost Area Description	Preproduction Capital Cost (\$M)	%
000	General Administration	47.2	4
200	Underground Mine	256.9	24
300	Mine Surface Facilities	81.8	8
400	Electrical & Communication	18.3	2
500	Site Infrastructure	13.2	1
600	Process Plant	379.4	36
700	Community Infrastructure and Relocation	36.1	3
800	Tailings and Water Management	68.5	6
900	Indirects	85.8	8
999	Contingency	75.0	7
	<b>Total</b>	<b>1,062.1</b>	<b>100</b>
	Less Outlays to August 31, 2017	(34.3)	-
	<b>Total – Forecast to Spend</b>	<b>1,027.8</b>	-

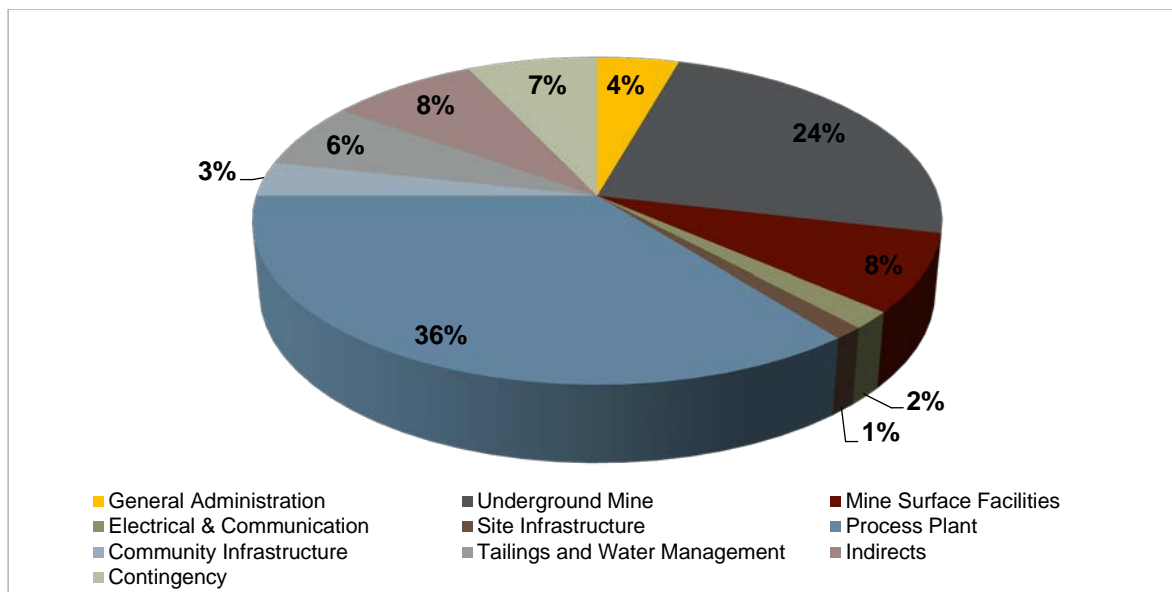

Figure 21-1: Distribution of preproduction capital costs

### 21.1.3.1 Direct Costs (Areas 000 to 800)

Direct cost details, based on the previously described assumptions, construction crew wages and productivities for the mine, process plant, site infrastructure, and tailings and water management are provided in the following sections according to the project WBS:

#### 21.1.3.1.1 General Administration (Area 000) – Owner’s Costs

The following items are part of the General Administration area, representing the owner’s costs during preproduction:

- Employee salaries until production begins;
- Energy, consumables and maintenance costs during mine development;
- Insurance during preproduction;
- Surface mobile equipment for the site and the warehouse;
- Environmental management and mitigation;
- Security;
- Pre-investment costs;
- Personnel training;
- Administration, financial and human resources costs;
- Community relations.

Falco’s estimation team provided the Owner’s costs with the exception of the mine preproduction Owner’s costs (\$18.7M), which were provided by InnovExplo. Owner’s costs total \$47.2M. Table 21-8 summarizes the General Administration preproduction capital costs.

**Table 21-8: General administration (Owner’s costs) preproduction capital cost summary**

<b>Cost Area Description</b>	<b>Total Cost (\$M)</b>
General Management	18.1
Mine Preproduction Owner’s Costs	18.7
Process Plant Preproduction Owner’s Costs	6.3
Insurance	2.1
Mobile Equipment	2.1
<b>Total</b>	<b>47.2</b>

### 21.1.3.1.2 Exploration and Geology (Area 100)

Exploration and geology work for the Horne 5 Project was completed prior to the effective date of the FS and is thus considered part of the Early Works. The exploration and geology costs have not been included in the preproduction capital costs.

### 21.1.3.1.3 Underground Mine (Area 200)

InnovExplo provided estimates totalling for all underground mine preproduction capital costs with the exception of the Quemont No.2 shaft rehabilitation and material handling infrastructure costs, which were provided by WSP, and the underground paste backfill and slurry networks and underground barricade costs, which were provided by Golder. The total underground mine preproduction capital cost is \$256.9M.

Table 21-9 summarizes the underground capital costs and provides a breakdown per item. Capital costs include material and manpower for each category.

**Table 21-9: Underground mine preproduction capital costs**

Item	Total Cost (\$M)
Dewatering, rehabilitation and shaft infrastructure	47.4
Underground construction	3.5
Underground permanent dewatering	13.3
Underground electrical and communications	19.0
Underground paste backfill network	7.3
Underground tailings network	14.3
Underground material handling	14.0
Underground ventilation	18.1
Contractor-operated development	92.0
Underground mobile equipment	20.7
Capitalised OPEX	7.3
<b>Total</b>	<b>256.9</b>

Dewatering, rehabilitation and shaft infrastructure costs (totalling \$47.4M) were provided by InnovExplo (\$4.7M), WSP (\$39.9M) and Golder (\$2.8M). The cost for the underground paste backfill network (\$7.3M) and underground tailings network (\$14.3M) were provided by Golder. Underground material handling costs (totalling \$14.0M) were provided by InnovExplo (\$1.2M) and WSP (\$12.8M). All other underground mine costs were provided by InnovExplo.

#### 21.1.3.1.4 Mine Surface Facilities (Area 300)

WSP provided estimates for the capital costs of the mine headframe and hoist room on surface, as well as for the stockpile feed conveyor. These costs were based on an estimate of bulk density for mineralized material coming from the underground and the hoisting rate as described in Chapter 16. Feasibility level engineering was performed to establish the design of skips, hoist cables and the production hoist. Based on the results obtained, manufacturers were approached to provide firm pricing of the equipment required. The production, service and auxiliary hoists have been purchased, including the mechanical and electrical design, supply and installation of the hoists.

The estimation methodology for areas 305, 310 and 315 was the same as is described for the process plant in Section 21.1.3.1.7. General arrangement drawings, sketches and 3D models were used to create MTO's which were used to prepare the civil, concrete, structural, architectural, mechanical, HVAC, piping, electrical and instrumentation/automation cost estimates. The capital cost of the material supply, equipment supply and installation of the headframe, the hoist room and the stockpile feed conveyor is estimated to be \$79.5M.

InnovExplo provided the capital costs for the mine surface air intake and air exhaust infrastructure, as well as the surface fuel delivery and distribution system, and some surface instrumentation and automation packages for the underground mine. The total capital cost of these items is estimated to be \$2.4M.

Total capital cost of the mine surface facilities is estimated to be \$81.8M.

**Table 21-10: Headframe, hoist room and conveyor preproduction capital costs**

Area	Cost Area Description	Total Cost (\$M)
305	Headframe	51.4
310	Hoist Room	26.1
315	Surface Material Handling	1.9
320 / 325 / 350	Air Intake / Air Exhaust / Fuel Reservoir / Surface Instrumentation	2.4
	<b>Total</b>	<b>81.8</b>

#### 21.1.3.1.5 Electrical and Communications (Area 400)

The electrical and communication capital costs were estimated by BBA. The main substation, site telecommunications and emergency power generation costs are based on other recent projects of similar size, power rating and layout, as well as firm pricing from suppliers for major electrical equipment.



Table 21-11 summarizes the preproduction capital cost estimate for the electrical and communication facilities.

**Table 21-11: Electrical and communication preproduction capital costs**

Area	Cost Area Description	Total Cost (\$M)
405	120 kV Transmission Line/HQ Substation Tie-In	2.5
410	120 kV Sub-Station	8.3
415	Electrical Site Distribution	0.3
430	Communication/IT System	6.7
435	Fresh Water Pump House Electrical & Communication	0.4
	<b>Total</b>	<b>18.3</b>

#### 21.1.3.1.6 Site Infrastructure (Area 500)

Site surface infrastructure capital costs were estimated by SNC-Lavalin, with the exception of the railway spur lines and storage area which was estimated by RIVVAL. The capital costs for all of the site infrastructure were determined by performing feasibility level engineering and architectural design to generate material take-offs as well as factored estimates based on building surface area. The firms then used their existing project database for both material supply and labour costs.

Assumptions used to determine the capital cost of site infrastructure (separate from the mine surface facilities and the process plant) include the following:

- The mine site is accessed using existing roads, which implies no major additional cost for site access road construction;
- Existing building demolition costs were estimated using the existing building plans and site visits;
- Capital for the service building, warehouse, mine building & dry, and administration building is based on material take-offs, factored estimates based on building surface area, and labour estimations to complete the work;
- Fire water system costs are included in the capital costs for each building, and are based on a preliminary design and a budget price for a design-built site-wide fire-protection package.
- Underground piping costs were estimated using a site layout and each of the building's requirements;

- The railway spur lines and siding storage tracks were estimated using a feasibility level design as the basis of a material take-off and labour cost estimate. This was based on the amount of rail cars required to meet the process plant’s cycle times between paste backfill binder requirements and zinc concentrate production rates.

A summary of the site surface infrastructure capital costs is provided in Table 21-12.

**Table 21-12: Site infrastructure preproduction capital costs**

Area	Cost Area Description	Total Cost (\$M)
505 / 510	Site Preparation, Public Road	1.4
520	Site Access Control	0.4
525	Administration Building	0.4
530	Mine Building & Dry	3.5
535	Warehouse	2.3
540	Service Building	0.6
550 / 555	Natural Gas & Fire Protection System	0.6
560 / 565	Potable Water & Sewage Disposal	0.4
575	Railway Storage Area & Spur Line	3.5
	<b>Total</b>	<b>13.2</b>

#### 21.1.3.1.7 Process Plant (Area 600)

The design of the processing plant was largely based on BBA and Falco experience on recent projects. The site plan provided by Falco and the 3D model and general arrangement drawings completed by BBA during the FS were used to estimate quantities and generate material take-offs (“MTOs”) for all commodities. Major mechanical and electrical equipment costs were estimated using firm proposals obtained from suppliers, while other equipment costs were estimated using budgetary proposals obtained from suppliers. Equipment of lower monetary value were estimated from BBA’s recent project data, when available. The costs for bulk material have been estimated using BBA’s experience and in-house database and were verified with budget pricing from local suppliers. A detailed equipment list was developed with equipment sizes, capacities, motor power, etc. Related infrastructure was estimated by BBA based on the site plan developed. Paste backfill plant direct costs (totalling \$20.9M), provided by WSP, are included in the processing area capital costs, as it is located within the process plant. Earthworks, concrete and structural steel costs of the paste backfill plant were provided by BBA as they were included with the rest of the process plant. All other process plant preproduction capital costs were provided by BBA.

The process plant preproduction capital costs are detailed in Table 21-13.

**Table 21-13: Process plant preproduction capital costs**

Area	Cost Area Description	Total Cost (\$M)
605	Ore Storage	18.3
609	Process Plant Building	71.2
610	Grinding	53.9
615 & 616	Flotation and Flotation Reagents	32.5
617 & 618	Concentrate Dewatering and Storage	8.6
620	Pre-Leach Thickening	13.8
625	Regrinding	32.8
630 & 631	Leaching and Oxygen Plant	14.6
635	Carbon-In-Pulp	22.4
640	Carbon Elution and Regeneration	11.0
645	Refining	1.3
650	Tailings Thickening	8.8
655	Cyanide Destruction	4.0
660	Tailings Storage and Pumping	4.2
665	Paste Backfill Plant	24.6
670	Reagent handling and distribution	12.6
675	Process Services	20.5
676 / 677 / 678	Process Plant Workshops/Offices/Laboratory	7.7
680 & 681	Electrical rooms	12.9
698	Mobile equipment	3.6
	<b>Total</b>	<b>379.4</b>

The following sections provide the basis for the capital cost estimates for the major component costs of constructing the process infrastructure.

### Civil

Earthwork quantities were estimated from drawings, topographical data and geotechnical information. Structural excavation and backfill volumes are based on a frost depth line of 2.3 m.

### Concrete

Preliminary design sketches and a 3D model were used to develop the concrete and embedded steel quantities. Unit rates are based on assemblies per type of concrete elements, i.e. piers, mats, walls, footings, etc. Budget quotes were received for concrete supply and installation hours were benchmarked with budget quotes from a local contractor.

### Structural

Using the 3D model and general arrangement drawings prepared by BBA and representative equipment loads, a structural 3D model was developed for all areas of the process plant. The model was used to create material take-offs. Material was priced from current steel market values and a budgetary proposal was obtained from a supplier and was benchmarked against similar projects.

### Architectural

Sandwich wall panel has been assumed for siding and standard membrane for roofing. The quantities were estimated from general arrangement drawings and from an architectural 3D model prepared by the firm Thibodeau Architecture+Design (“TAD”). Fire resistant panels are included around the gold room and electrical rooms. Pricing is based on TAD’s historical data and budgetary proposals for major material items. TAD supplied direct labour hours and BBA applied the project unit architectural hourly rate.

### Mechanical

An equipment list, including platework, was developed from the process flow diagrams. Firm price quotes were received for all major mechanical equipment supply. All other equipment and platework are identified with sizing and weights, include lining requirements and budgetary quotes were received for typical platework types and applied throughout the process plant. Installation hours were estimated using BBA’s internal database and benchmarked with budget quotes from several local contractors.

HVAC and fire protection prices were obtained from vendors who have recently worked on similarly sized facilities and have been benchmarked from recent projects executed by BBA.

### Piping

Complete piping diagrams were prepared. Pipe lining requirements were also categorized. Lengths for each line shown on the piping diagrams were determined from layout drawings. Material pricing for carbon steel and rubber-lined piping was obtained from supplier proposals.

## Electrical

An equipment list, including capacities and sizing, has been developed from the electrical single line diagram. MTOs for electrical bulk quantities were prepared by sub area based on similar installations designed by BBA. Major electrical equipment costs were estimated using firm proposals obtained from suppliers, other equipment costs were estimated using budgetary proposals obtained from suppliers while equipment of lower monetary value were estimated from BBA's recent project data. Electrical bulk material pricing was obtained from BBA's historical cost data. Lighting has been estimated by factoring other projects based on surface area.

## Automation/Telecommunications

An instrumentation list was developed from the process flow diagrams using typical instrumentation assemblies developed by BBA. A telecommunications components list was also developed in a similar fashion. Pricing is based on BBA's historical data.

### 21.1.3.1.8 Community Infrastructure and Relocation (Area 700)

Costs for the community infrastructure and relocation were provided by Falco and are mostly comprised of industrial and institutional relocation as well as on negotiations with current land owners for property acquisition costs. Preliminary architectural designs were used to estimate the cost of new or renovated buildings and sites required to complete the relocations. Table 21-14 summarizes the community infrastructure and relocation preproduction capital costs.

Table 21-14: Community infrastructure and relocation preproduction capital costs

Area	Cost Area Description	Total Cost (\$M)
710	Rouyn-Noranda School Board Relocation	22.5
715	Industrial Building Relocation	10.0
720	Recycling Plant	0.8
725	Playground Reconstruction	2.2
730	Municipal Works and Land Purchase	0.6
	<b>Total</b>	<b>36.1</b>

### 21.1.3.1.9 Tailings and Water Management (Area 800)

The tailings and water management preproduction program at Horne 5 envisions six main areas: the acquisition of the surface tailings management facility and the management of waste rock during the development phase of the mine, surface water management, a fresh water pump house and pipeline, preproduction water treatment plant capital and operating costs, dewatering pumping, pipelines and surface sludge infrastructure, and underground sludge distribution. The capital costs for the underground tailings disposal system are included in the capital costs for the underground mine while the capital costs for the paste backfill plant are included in the capital costs for the process plant. The total preproduction capital cost of tailings and water management for the Horne 5 Project is estimated to be \$68.5M, and is summarized in Table 21-15.

Table 21-15: Tailings and water treatment preproduction capital costs

Area	Cost Area Description	Total Cost (\$M)
805 / 810	Surface Tailings Management Facility / Waste Rock Transport	6.7
825 / 830	Fresh Water Pumping Station and Pipeline	2.0
835	Preproduction Water Treatment Plant CAPEX and OPEX	45.8
840	Site Water Management Infrastructure	2.4
870 / 873 / 874	Dewatering Pumping and Pipelines & Surface Infrastructure	5.5
880 / 881	Underground Sludge (HDS) Distribution	6.2
	<b>Total</b>	<b>68.5</b>

#### Surface Tailings Management Facility and Waste Rock Pile

The preproduction capital cost for the purchase of the surface tailings management facility site and the transport cost of waste rock from the Horne 5 Mining Complex to the TMF site was estimated by Falco based on negotiations with the current owners and estimates from local contractors for the transport of waste rock. The associated preproduction capital cost is estimated to be \$6.7M.

### Fresh Water Pump House and Pipeline

The preproduction capital cost estimate for the fresh water pumping infrastructure and pipelines was estimated by Golder for a total of \$1.8M. BBA provided the electrical and instrumentation estimate of \$0.16M. The total preproduction capital is estimated to be \$2.0M, which includes a 1-km access road, a pump house on Rouyn Lake, a pipeline from the pump house to the tie-in to the preproduction treated water pipeline and some electrical and instrumentation costs at the pump house. The capital costs related to the 2.5-km electrical line tie-in is found in area 435 (Fresh Water Pump House Electrical & Communication).

### Preproduction Water Treatment Plant Capital and Operating Costs

Capital cost estimates for the preproduction water treatment plant as well as the operating costs during dewatering, were compiled by Golder. The total preproduction capital associated with water treatment is estimated to be \$45.8M.

### Surface Water Management

The preproduction capital cost for the surface water management for the Horne 5 Mining Complex was estimated by Golder. It is to be constructed so that collected site water is pumped to the process plant building allowing for an efficient management of site water. The preproduction capital cost for surface water management is estimated to be \$2.4M.

### Dewatering Pumping, Pipelines and Sludge Surface Infrastructure

The preproduction capital cost estimate for the treated water and sludge pipelines and sludge surface infrastructure were supplied by Golder for a total of \$4.4M. A portion of the preproduction treated water pipeline will be re-purposed as a section of the fresh water pipeline.

Falco estimated the costs for some sludge booster pumps at the Donalda site for a total of \$0.4M. InnovExplo provided an allowance of \$0.65M for surface pipelines from the mine shafts to the water treatment plant. The total preproduction capital for dewatering pumping, pipelines and sludge surface infrastructure is estimated to be \$5.5M.

### Underground Sludge Distribution

The preproduction capital cost estimate for underground sludge distribution was estimated by Golder. The total preproduction capital is estimated to be \$6.2M, which includes surveys, drill holes, piping and valves to distribute water treatment sludge in Donalda and Quemont underground workings.

#### 21.1.3.1.10 Direct Cost Summary

The overall direct costs for the Horne 5 Project totals \$901.3M.



### 21.1.3.2 Indirect Costs (Area 900)

Indirect costs include all costs needed to carry out the engineering, procurement, and construction management services for the Project. These costs were calculated by Falco's estimating group. The main costs in this category are EPCM services, temporary facilities, third-party services, spare parts, freight, and customs. The construction contractors' indirect costs are included in the construction direct costs.

For the Project indirect costs included within the preproduction capital cost estimate, an itemized list of elements has been used to generate factored estimates. The following have been covered:

- EPCM;
- Costs associated with permitting and public consultations;
- Construction temporary facilities erection and operation;
- Land and ocean freight for process and major electrical equipment;
- Pre-operational verifications;
- Commissioning support;
- Vendor representatives;
- Capital spares;
- One year operating spares;
- Commissioning spares;
- First fills;
- Waste disposal;
- Sanitary blocks;
- Construction temporary power.

The indirect costs were calculated using various sources of information, including the construction execution plan and information provided by Falco. Indirect costs, excluding Owner's costs, (see WBS 000) total \$85.8M.

### 21.1.3.3 Contingency (Area 999)

Contingency is an allowance included in the preproduction capital cost estimate that is expected to be spent to cover unforeseeable items within the scope of the estimate. These can arise due to currently undefined items of work or equipment, or to uncertainty in the estimated quantities and unit prices for labour, equipment and materials. Contingency does not cover scope changes or project exclusions.

The pre-production cost contingency was calculated for the Project as a whole by Falco using a deterministic approach based on their experience, execution philosophy, historic data, assessment of major risks/opportunities, level of project definition and advancement of engineering as well as contributions from the various firms according to their scope of work.

Firm price proposals were received for all major mechanical and electrical equipment as well as for underground mine mobile equipment and the Quemont No. 2 shaft rehabilitation. No contingencies were applied to these direct costs. The following Table 21-16 provides a summary of the packages for which proposals were received.

**Table 21-16: Firm price quotations list**

<b>Equipment List</b>	<b>Capital Cost (\$M)</b>
Underground Mine Mobile Equipment	19.4
Hoisting Equipment and Accessories	46.6
Electrical Sub-Station Equipment	3.3
Process Plant Equipment	76.7
Water Treatment Equipment	7.7
Shaft Rehabilitation	23.5
<b>Total Capital Cost</b>	<b>177.2</b>

The total amount calculated for the contingency is \$75M representing 7% of the preproduction capital costs.

It is expected that in order to meet the budget for the Project sufficiently developed engineering, adequate project management and tight construction cost controls will be implemented.

#### **21.1.4 Sustaining Capital Cost**

Sustaining capital costs were estimated using the same estimation basis as outlined for the preproduction direct costs. The sustaining capital is for planned future capital works for the Project, mainly tailings management facility initial construction and following construction stages, the surface tailings and reclaim water pipelines, Phase 2 mine ramp and ore/waste pass extensions and associated infrastructure, Quemont No. 2 shaft re-sinking and mine mobile equipment replacement and overhauls. The sustaining capital costs for each area include indirect costs and contingencies, where applicable.

Total sustaining capital costs incurred over the approximate 15 years of production are \$535.4M of project-related capital expenditures, excluding end-of-mine site reclamation and closure costs. The sustaining capital costs, including site closure and restoration, net of salvage value, is

\$577.6M. The breakdown of LOM sustaining capital expenditures by area is provided in Table 21-17 and Figure 21-2, while a detailed sustaining capital schedule is provided in Table 21-18.

Table 21-17: Project sustaining capital cost summary

Area	Description	Sustaining Capital Cost (\$M)	%
200	Underground Mine	325.1	60.7
300	Mine Surface Facilities	4.7	0.9
400	Electrical and Communication	2.3	0.4
600	Process Plant	13.0	2.4
800	Tailings and Water Management	190.3	35.5
	<b>Total</b>	<b>535.4</b>	<b>100</b>
	Site Reclamation and Closure	87.2	-
	Salvage Value	(45)	-
	<b>Total</b>	<b>577.5</b>	<b>-</b>

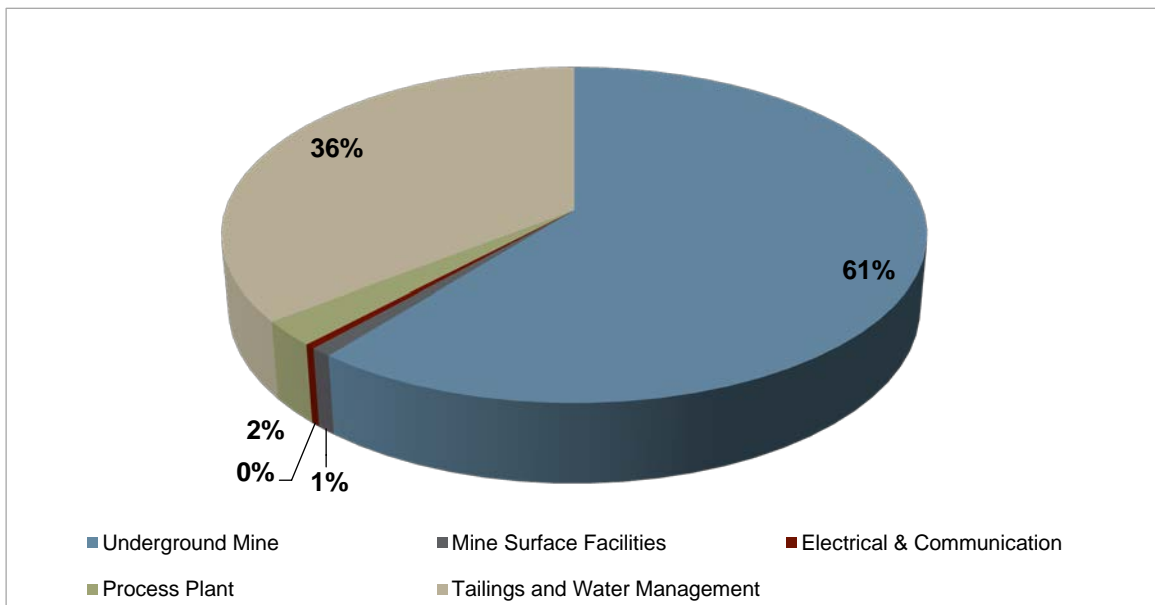

Figure 21-2 Project sustaining capital cost summary

Table 21-18: Sustaining capital costs by year summary

	Year	2021	2022	2023	2024	2025	2026	2027	2028	2029	2030	2031	2032	2033	2034	2035	Total
Area	Description	Sustaining Capital Cost (\$M)															
200	Underground Mine	45.9	45.9	27.0	25.0	26.3	28.4	35.8	41.8	13.3	6.6	6.0	3.9	9.0	7.0	3.3	<b>325.1</b>
300	Mine Surface Facilities	-	-	-	-	-	-	-	4.7	-	-	-	-	-	-	-	<b>4.7</b>
400	Electrical and Communication	-	-	2.3	-	-	-	-	-	-	-	-	-	-	-	-	<b>2.3</b>
600	Processing	-	-	13.0	-	-	-	-	-	-	-	-	-	-	-	-	<b>13.0</b>
800	Tailings & Water Management	-	92.5	48.1	13.4	-	9.7	8.9	8.9	-	-	4.4	4.4	-	-	-	<b>190.3</b>
	<b>Total</b>	<b>45.9</b>	<b>138.4</b>	<b>90.4</b>	<b>38.4</b>	<b>26.3</b>	<b>38.1</b>	<b>44.6</b>	<b>55.4</b>	<b>13.3</b>	<b>6.6</b>	<b>10.3</b>	<b>8.3</b>	<b>9.0</b>	<b>7.0</b>	<b>3.3</b>	<b>535.4</b>

#### 21.1.4.1 Underground Mine (Area 200)

A large portion of sustaining capital costs is attributable to the underground mining operation. The underground mine related sustaining capital costs are estimated to be \$325.1M and are broken down by activity in Table 21-19. Significant sustaining capital is required as mining progresses. Sustaining capital includes drifts, ventilation raises, ramp extension, underground infrastructure, underground electrical and communications, underground material handling, paste backfill network, and mobile equipment. Also included in mine-related sustaining capital is the major spend for the Phase 2 shaft re-sinking, which is estimated at \$40M in years 2027 and 2028 respectively. The underground mining sustaining capital costs are summarized in Table 21-19.

InnovExplo provided estimates for all underground mining sustaining capital costs, with the exception of the Quemont No. 2 shaft re-sinking and rehabilitation for mine Phase 2 (\$40.0M) which was provided by WSP and the underground paste backfill network (\$16.5M), which was provided by Golder.

Table 21-19: Underground sustaining capital costs

Item	Total Cost (\$M)
Shaft re-sinking and rehabilitation	40.0
Underground paste backfill network	16.5
Underground construction	6.4
Underground permanent dewatering	6.0
Underground electrical and communications	18.0
Underground material handling	31.0
Underground ventilation	12.6
Owner-operated development	93.4
Contractor-operated development	17.3
Underground mobile equipment	84.0
<b>Total</b>	<b>325.1</b>

#### 21.1.4.2 Mine Surface Facilities (Area 300)

Once the re-sinking of the Quemont No. 2 shaft is complete, the existing ropes for the production, service and auxiliary hoists will be replaced with longer ropes. This will enable the hoists to access the new shaft bottom and the ore handling infrastructure for Phase 2 of the mine. The sustaining capital costs for the mine surface facilities area are summarized in Table 21-20.

Table 21-20: Mine surface facilities sustaining capital costs

Cost Area Description	Total Cost (\$M)
Production, service and auxiliary rope replacement	4.7
<b>Total</b>	<b>4.7</b>

#### 21.1.4.3 Processing (Area 600)

With the requirement of a surface TMF following year two of operations, new tailings pumps and associated electrical equipment will be installed in the process plant in order to transport the slurry from the Horne 5 Mining Complex to the surface TMF. Golder provided the costs for the pumps, totalling of \$11M while BBA provided \$2M for the associated electrical equipment, material and installation. The sustaining capital costs for the processing area are summarized in the following table:

Table 21-21: Processing sustaining capital costs

Cost Area Description	Total Cost (\$M)
Tailings Pumps and associated electrical equipment	13.0
<b>Total</b>	<b>13.0</b>

#### 21.1.4.4 Tailings and Water Management (Area 800)

Once the voids in the historic Horne mine are filled with slurry tailings, a surface tailings management facility will be required. The sustaining capital cost estimates for the tailings and water management area were provided by Golder and are summarized in the following table:

Table 21-22: Tailings and water management sustaining capital costs

Cost Area Description	Total Cost (\$M)
Surface Tailings Management Facility	112.3
TMF Surface Water Management	17.7
Tailings and Reclaim Water Pipelines	57.6
Water Treatment Plant Relocation	2.6
<b>Total</b>	<b>190.3</b>

The costs included in the table above represent the pipelines required to pump tailings from the Horne 5 Mining Complex to the TMF, the TMF infrastructure required to store both PCT and PFT, infrastructure to properly manage the surface water at the TMF site and the relocation of the existing water treatment plant, which is currently in operation but will need to be relocated in order to distribute tailings with the new TMF configuration.

#### 21.1.4.5 Rehabilitation and Site Closure

Site reclamation and closure costs are estimated to total \$87.2M. This estimate includes the reclamation, dismantling and removal of Horne 5 Mining Complex surface infrastructure and restoration of the tailings management facility, as well as the associated monitoring and engineering activities. These activities are expected to commence in 2035, coinciding with the termination of operations. Table 21-23 provides a breakdown of the costs associated with site rehabilitation and closure.

Table 21-23: Site rehabilitation and closure

Cost Area Description	Total Cost (\$M)
Restoration of the Horne 5 Mining Complex	18.2
Restoration of Tailings Management Facility	69.0
<b>Total</b>	<b>87.2</b>

#### 21.1.4.6 Salvage Value

The salvage value of mechanical, electrical and underground mobile equipment was estimated to total \$45M. Table 21-24 provides a breakdown of the costs associated with the salvage value of equipment from the Horne 5 Mining Complex.

Table 21-24: Salvage value

Cost Area Description	Total Cost (\$M)
Underground Mine Mobile Equipment	7.0
Hoisting Equipment	5.4
Process Plant Equipment	32.6
<b>Total</b>	<b>45.0</b>



## 21.2 Operating Costs

### 21.2.1 Summary

The average operating cost over the LOM is estimated to be 41.00 \$/t. Table 21-25 and Figure 21-3, below, provides the breakdown of the projected operating costs for the Horne 5 Project.

Table 21-25: Project operating cost summary

Cost Area Description	LOM Total \$M	Average LOM (\$M/Year)	Average LOM (\$/tonne)	OPEX (%)
Mining	1,020	68	12.60	31
Processing	1,654	110	20.45	50
Tailings and Water Management	411	27	5.08	12
General and Administration	231	15	2.86	7
<b>Total</b>	<b>3,316</b>	<b>221</b>	<b>41.00</b>	<b>100</b>

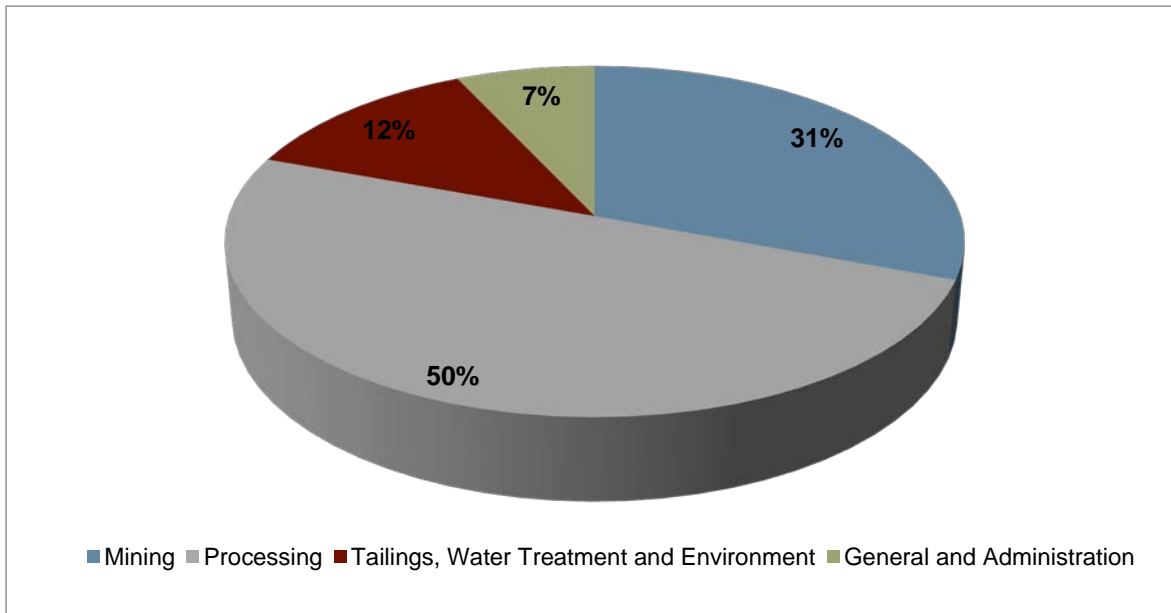

Figure 21-3: Project operating cost summary

## 21.2.2 Basis of Operating Cost Estimate

The operating cost estimate was based on Q1 2017 assumptions. The estimate has an accuracy of  $\pm 10\%$ . All operating cost estimates are in CAD. Mining, process and tailings management are generally itemized in detail, however, General and Administration (“G&A”) items are calculated estimates, or have been included as an allowance. Many items of the operating cost estimate are based on budget quotations, allowances are based on in-house data and salaries are based on Falco’s projected salary chart.

The operating cost estimate is based on the mine schedule indicative tonnage per time period that was produced by InnovExplo on August 26, 2017 and inclusive of site costs to final Project close-out (“LOM”) including waste management facilities. Costs up to and including C4 commissioning are excluded from operating costs and are included in the capital cost estimate.

### 21.2.2.1 Assumptions and Exclusions

The following items were assumed:

- All equipment and materials will be new;
- The labour rate build-up will be based on the statutory laws governing benefits to workers that were in effect at the time of the estimate;
- No cost of commissioning assistance post C4 certificate issuance is included in the operating cost estimate;
- Freight estimates are based on vendor supplied freight quotations or in-house data. Freight for reagents is included in the price of those commodities. Freight for steel consumables is included in the price of that material. Freight for spare parts is calculated as a percentage of equipment cost expected to be used annually;
- No contingency is assumed;
- No cost escalation (or de-escalation) is assumed;
- No costs relating to certain agreements with third parties.

The following items were specifically excluded from the operating cost estimate, unless identified by the Owner’s team and included in the Owner’s costs:

- Cost of financing and interest;
- Pre start-up operations and maintenance training;
- Transport and handling of concentrate and doré from the plant (included in the financial analysis).

### 21.2.2.2 Estimate Responsibilities

The overall operating cost estimate combined inputs from a number of sources including BBA, InnovExplo, Golder, WSP, and Falco as summarized in Table 21-26.

Table 21-26: Operating cost estimate combined inputs

Cost Area	Responsible Entity
Mining	InnovExplo
Process Plant	BBA
Tailings, Water Management and Environment	Golder, WSP, Falco
General and Administration	Falco

### 21.2.2.3 General Unit Rates

General rates used in the estimate are summarized in Table 21-27.

Table 21-27: General rate and unit cost assumptions

Parameter	Unit	Value
Average Daily LOM Tonnage	tpd	15,500
Years of Operations	year	15
LOM Production	M tonnes	80.9
LOM Gold Grade	Au g/t	1.44
LOM Silver Grade	Ag g/t	14.14
LOM Copper Grade	Cu %	0.17
LOM Zinc Grade	Zn %	0.77
LOM Sulphur Grade	S %	18.7
Power	\$/kWh	0.0525
Natural Gas	\$/m <sup>3</sup>	0.341
Diesel Fuel	\$/L	1.00

### 21.2.3 Underground Mining

Total operating costs and costs per tonne over the LOM for underground production are summarized in Table 21-28 and annual amounts are summarized in Table 21-30. These costs include material and manpower for each individual category. Unit costs used in the estimation of mine development costs are summarized in Table 21-29.

Table 21-28: Underground mining operating costs

Activity	Sub-Activity	Total LOM Cost (\$M)	Average LOM Cost (\$/t mined)	Percentage of Mine OPEX (%)
Grade Control	Definition drilling	3.0	0.04	-
	<b>Subtotal</b>	<b>3.0</b>	<b>0.04</b>	<b>1</b>
Mine Development	Mine development	157.7	1.95	-
	<b>Subtotal</b>	<b>157.7</b>	<b>1.95</b>	<b>15</b>
Production	Slot raise	67.9	0.84	-
	Stope support	41.5	0.51	-
	Extraction	213.6	2.64	-
	Mucking & Hauling	73.1	0.90	-
	<b>Subtotal</b>	<b>396.1</b>	<b>4.90</b>	<b>39</b>
Services	Ore handling	35.7	0.44	-
	U/G services	194.1	2.40	-
	Energy cost	101.7	1.26	-
	Mechanical services	76.5	0.95	-
	Electrical services	54.7	0.68	-
	<b>Subtotal</b>	<b>462.8</b>	<b>5.72</b>	<b>45</b>
	<b>Total</b>	<b>1,019.6</b>	<b>12.60</b>	<b>100</b>

Table 21-29: Unit costs for development

Development	Mine Phase 1 (\$/m)	Mine Phase 2 (\$/m)	Contractor (\$/m)
Ramp 5.5 m x 5.4 m	2,497	2,531	3,190
Drift and draw point 4.5 m x 5.4 m	2,381	2,413	2,745
Footwall drift in ore 4.5 m x 5.4 m	2,630	-	2,745
Drift in backfill	2,424	2,424	-
Rehabilitation	512	512	2,059
Slash and Rehabilitation	1,828	-	2,333
Rehabilitation (2.4 m x 2.4 m drift)	-	-	1,506
Double drift	-	-	6,394
Services (equivalent m)	-	-	3,500
Raisebore 6 m diameter	-	-	6,786
Raisebore 4 m diameter	-	-	4,505
Raisebore 2.4 m diameter	-	-	3,332

Table 21-30: Underground mining operating costs – dollars per year

	Mine General	2021	2022	2023	2024	2025	2026	2027	2028	2029	2030	2031	2032	2033	2034	2035	Total
<b>Grade control</b>	Definition drilling	68,480	191,557	187,519	189,228	188,759	190,052	181,662	190,940	213,510	248,092	252,331	254,105	252,927	249,165	138,910	<b>2,997,238</b>
<b>Mine Development</b>	Mine development	19,376,243	8,196,185	8,897,925	8,254,106	7,605,415	8,841,628	5,992,742	7,463,165	12,012,806	16,055,487	14,216,108	11,322,005	10,970,241	8,203,247	10,318,234	<b>157,725,537</b>
<b>Production</b>	Slot raise	1,793,869	5,017,946	4,912,164	4,956,938	4,944,640	4,978,508	4,758,741	4,785,190	4,720,162	4,805,224	4,887,334	4,921,691	4,898,886	4,826,010	2,690,520	<b>67,897,821</b>
	Stope support	1,096,977	3,068,546	3,003,859	3,031,239	3,023,719	3,044,429	2,910,039	2,926,213	2,886,447	2,938,464	2,988,675	3,009,685	2,995,739	2,951,175	1,645,292	<b>41,520,499</b>
	Extraction	5,643,027	15,785,102	15,452,342	15,593,189	15,554,502	15,661,041	14,969,713	15,052,915	14,848,355	15,115,936	15,374,232	15,482,312	15,410,571	15,181,324	8,463,649	<b>213,588,212</b>
	Mucking & Hauling	1,775,003	4,965,173	4,860,504	4,904,808	4,892,639	4,926,150	4,708,694	4,734,865	4,670,521	4,754,689	6,129,730	6,103,902	6,137,132	6,011,909	3,535,582	<b>73,111,303</b>
<b>Services</b>	Ore handling	1,098,958	2,551,741	3,057,480	2,596,912	2,596,912	3,057,480	2,596,912	2,558,704	3,352,599	2,892,031	1,936,095	2,396,662	1,936,095	1,936,095	1,168,394	<b>35,733,069</b>
	U/G services	4,606,549	14,474,468	14,517,399	14,002,225	14,002,225	14,002,225	14,002,225	14,002,225	14,002,225	14,002,225	14,002,225	14,002,225	12,886,014	12,886,014	8,756,142	<b>194,146,611</b>
	Energy cost	3,204,256	6,710,926	6,794,614	7,413,705	7,499,882	7,492,847	7,519,454	7,601,640	7,869,676	7,075,334	7,075,334	7,075,334	7,075,334	7,075,334	4,245,200	<b>101,728,871</b>
	Mechanical services	1,578,152	5,001,149	5,519,542	5,528,170	5,528,170	5,528,170	5,528,170	5,528,170	5,528,170	5,528,170	5,618,170	5,618,170	5,618,170	5,618,170	3,200,134	<b>76,468,844</b>
	Electrical services	1,345,717	3,934,430	3,934,430	3,934,430	3,934,430	3,934,430	3,934,430	3,934,430	3,934,430	3,934,430	3,934,430	3,934,430	3,934,430	3,934,430	2,191,002	<b>54,684,306</b>
<b>Total</b>		<b>41,587,230</b>	<b>69,897,225</b>	<b>71,137,779</b>	<b>70,404,950</b>	<b>69,771,291</b>	<b>71,656,960</b>	<b>67,102,782</b>	<b>68,778,456</b>	<b>74,038,901</b>	<b>77,350,081</b>	<b>76,414,663</b>	<b>74,120,521</b>	<b>72,115,540</b>	<b>68,872,872</b>	<b>46,353,059</b>	<b>1,019,602,311</b>

## 21.2.4 Process Plant

Process plant operating costs were calculated for each year of the LOM. An average annual cost was then determined on this basis to be approximately \$110.2M, or 20.45 \$/t milled. These amounts exclude the operation of the paste backfill plant, which is costed in Section 21.2.5.

Operating costs incurred during the ramp-up/commissioning period were included in the above calculation although accounted as capital expenditures in the financial model.

The average operating costs include reagents, grinding media, process consumables and maintenance parts and material, personnel, maintenance contractors, electrical power, natural gas, as well as external laboratory assays and an allowance for special projects. The process consumables include mill liners, screen decks and concentrate filter cloths.

A breakdown of the average process plant operating costs, without contingency, is presented in Table 21-31 and illustrated in Figure 21-4.

Table 21-31: Process plant operating cost summary

Cost Area	Annual Cost (\$M/year)	Cost per tonne milled (\$/t)	Percentage of Process Plant OPEX (%)
Reagents	41.8	7.74	37.9
Grinding Media	20.0	3.70	18.1
Maintenance Parts & Materials	8.5	1.58	7.7
Major Equipment Consumables	2.5	0.46	2.3
Personnel & Contractors	13.3	2.46	12.0
Utilities (Power & Gas)	22.4	4.15	20.3
Miscellaneous	1.8	0.34	1.7
<b>TOTAL</b>	<b>110.2</b>	<b>20.45</b>	<b>100.0</b>

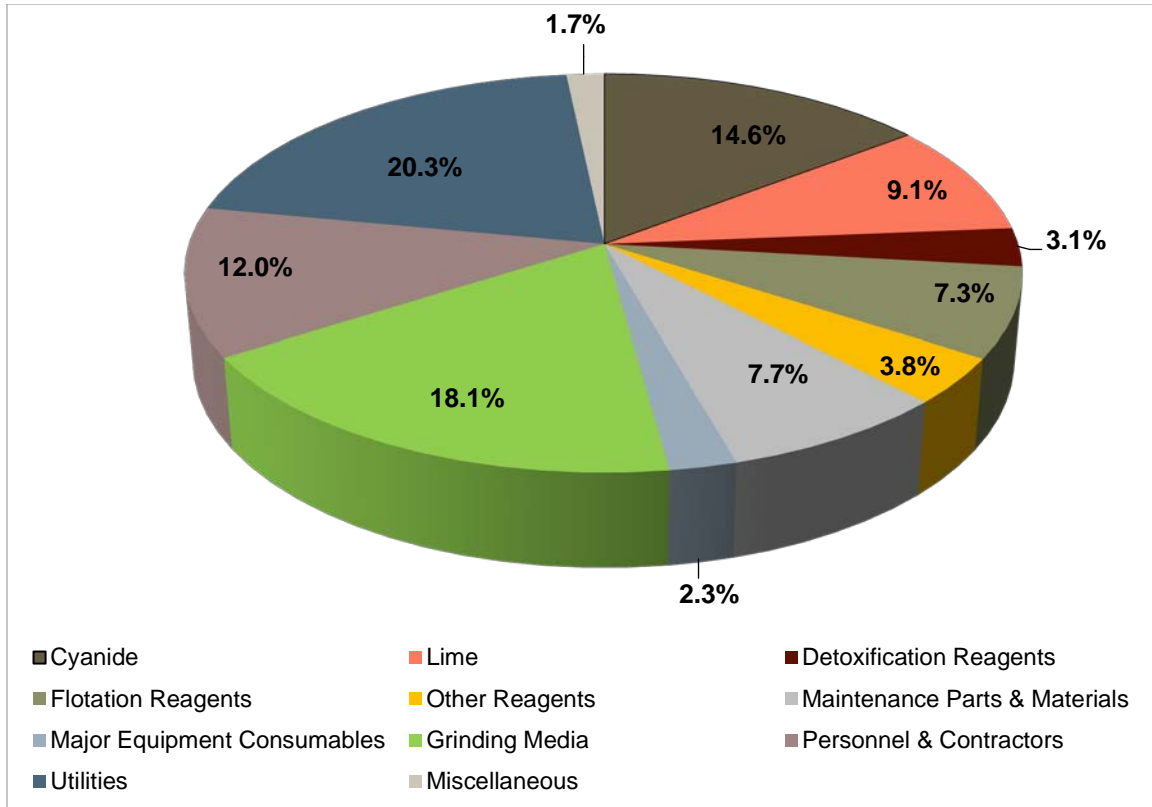

Figure 21-4: Process operating cost breakdown

#### 21.2.4.1 Personnel

A total of 89 workers are required in the process plant, including 35 salaried staff and 54 hourly workers divided into management and technical services, operations and maintenance departments. The list of personnel, along with their salaries, benefits and bonuses associated with each position was provided by Falco. The personnel cost is \$10.0M per year, or 1.85 \$/t milled.

To this amount is added the contribution of contractors, called upon to complete maintenance tasks during plant shutdowns scheduled for preventive maintenance, as well as completing equipment rebuilds in their own shops. A total of 45K hours per year are thus budgeted, at a cost of \$3.3M for an average year, or 0.61 \$/t milled over the LOM considering lower expenditures in the first and last year.



#### 21.2.4.2 Reagents

Several reagents are included in the Horne 5 process flowsheet, covering the needs of three differential flotation circuits, as well as leaching, CIP and cyanide destruction circuits for both the pyrite concentrate and flotation tailings.

The reagent consumptions were estimated based on testwork results and are detailed in Chapter 17. Budgetary prices, including delivery to site, were obtained for all reagents.

Consumptions of some reagents are directly tied to the plant throughput; such as the elution reagents, antiscalant, MIBC, carbon and lime added in the flotation circuit. Some consumables are estimated based on the feed grades encountered, such as collectors and copper sulphate, which are tied to copper and/or zinc, or sulphur content. Finally, the reagents used in the leach circuits (lime, cyanide) and those used in the cyanide destruction circuits (sulphuric acid, hydrogen peroxide and lime) are based on the pyrite concentrate and flotation tails tonnages.

A summary of the average annual cost over the LOM for each of the reagents is presented in Table 21-32.

Table 21-32: Annual reagent costs

Reagent	Annual Cost (\$M/year)	Percentage Reagent Costs (%)
Lime	10.02	24.0
Potassium Amyl Xanthate ("PAX")	0.95	2.3
Sodium Isopropyl Xanthate ("SIPX")	0.68	1.6
Aerofloat R208	0.41	1.0
Copper Sulphate (CuSO <sub>4</sub> •5H <sub>2</sub> O)	3.59	8.6
Methyl Isobutyl Carbinol ("MIBC")	2.41	5.8
Sodium Cyanide (NaCN)	16.11	38.6
Oxygen	0.54	1.4
Caustic (NaOH - 50%)	1.25	3.2
Hydrochloric Acid (HCl - 32%)	0.74	1.9
Sulphuric Acid (H <sub>2</sub> SO <sub>4</sub> - 93%)	1.57	3.8
Hydrogen Peroxide (H <sub>2</sub> O <sub>2</sub> – 70%)	1.86	4.5
Flocculant	0.74	1.9
Antiscalant	0.16	0.4
Carbon	0.60	1.6
Refining Fluxes	0.14	0.4
<b>TOTAL</b>	<b>41.76</b>	<b>100.0</b>

The annual cost of reagents is \$41.76M, or 7.74 \$/t milled. Lime and cyanide alone represent 62.6% of the reagent costs.

#### 21.2.4.3 Major equipment consumables, maintenance spares and materials

The replacement costs of major equipment consumables such as the SAG and ball mill liners, scalping screen deck and filtration cloths were calculated based on benchmarked or recommended change-out schedules and budgetary quotations. These costs average \$2.49M per year or 0.46 \$/t milled.

The maintenance cost of the process plant equipment, as associated with the replacement of spare parts and use of miscellaneous materials, including lubricants, was calculated by applying fixed percentages to the indicated equipment capital cost of a given area. The processing areas and percentages applied to the mechanical, electrical and instrumentation equipment, as well as the piping materials in the process plant, are presented in Table 21-33.

Table 21-33: Annual process plant maintenance costs by area

Process Plant Equipment	Percentage of Capital Cost Applied (%)	Annual Cost (\$M/year)
Mechanical		
▪ Ore Handling	9.5	0.39
▪ Grinding	8.0	1.89
▪ Flotation	6.0	0.78
▪ Leach, CIP, CND	4.0	2.64
▪ Plant Services	3.0	0.24
Electrical	2.0	0.81
Piping	10.0	1.07
Instrumentation	3.0	0.36
Architectural	n/a	0.25
<b>TOTAL</b>		<b>8.42</b>

To the costs indicated in Table 21-33 are added the rental costs of mobile equipment from contractors during major shutdowns. These represent \$0.64M per year of full operation. The maintenance costs for a full production year are thus \$9.06M, or \$8.51M (1.58 \$/t milled) as a LOM average with the effect of a reduced maintenance pace planned during the last year of operation.

#### 21.2.4.4 Grinding media

The Horne 5 process flowsheet includes three types of grinding media including steel media for both the SAG and ball mills, and ceramic media for the fine regrind mills. The consumption rates for the Ø125 mm SAG mill and Ø50 mm ball mill media were calculated using the empirical Bond approach, to which credits were applied to reflect the advances in media metallurgy and heat treatment since the underlying equations were devised. The input data considered the average operating conditions for the SAG and ball mills, in terms of power draw, rotational speed and media loading.

The Ø2.5 mm ceramic media wear rate for the regrind mills was based on vendor recommendations. Consumed power is kept to the installed base, allowing for variable recovery as the resulting product P<sub>80</sub> varies with pyrite concentrate tonnage production.

Budgetary quotations were obtained for each type of media used. The wear and average annual media consumption rates for each type are presented in Table 21-34.

Table 21-34: Media wear and consumption rates

Process Plant Equipment	Wear Rate (g/kWh)	Annual Cost (M\$/year)
SAG – Ø125 mm steel media	77	8.35
Ball mill – Ø75-Ø50 mm steel media	76	7.85
Regrind mill – Ø2.5 mm ceramic media	10	3.78

The average annual cost of media was estimated to be \$19.97M or 3.70 \$/t milled, which represents 18.1% of the process plant operating costs.

#### 21.2.4.5 Electricity

The total power consumption for the processing facility was estimated to be 404.3 GWh, including 2% network losses for transmission and transformation to 4.1 kV.

The process plant energy consumption was calculated based on the mechanical equipment list and installed motor base for all equipment other than the SAG, ball, and regrind mills. In these cases, the grinding energy requirements were calculated based on the specific energy requirements for each application and are variable with the ore hardness, inversely proportional to the ore sulphur content.

For other equipment, individual load, utilization and transmission factors were applied to derive the power used, which is then deemed fixed: including the regrind mill power input (held constant to maximize reground product size and pyrite concentrate leach recovery) 59.4% of the plant power load is thus deemed as fixed (e.g. not varying with throughput). Of this value, 56.7% of the expended power is tied to the regrind mills.

The specific energies (kWh/t) for both the SAG and ball mills were estimated from the testwork data and motor input specific energy, as determined by the relationship between grinding work indices and sulphur content, to grind the material from a feed size ( $F_{80}$ ) of 150 mm to a product size ( $P_{80}$ ) of 55  $\mu\text{m}$ . The specific energies were converted to an annual power demand (GWh) based on the annual tonnage processed through the mills. The SAG mill power consumption is thus representing 16.3% of the plant total while that of the ball mill accounts for another 24.3%.

The electrical power costs represent 18.8% of the total process operating costs, at \$20.3M or 3.76 \$/t milled.

#### 21.2.4.6 Natural Gas

Natural gas is used for the process plant building heating and for operation of the carbon regeneration kiln and elution solution boilers.

The building volume, air exchange rates and the estimated heat loss were used to calculate heating requirements.

The fuel requirement for the gold stripping and carbon regeneration was calculated based on the running loads of the equipment and a natural gas vs. electricity efficiency factor.

For an average production year, it is estimated that 6.3  $\text{Mm}^3$  of natural gas will be required in the process plant at a price of 0.341 \$/m<sup>3</sup>. The annual cost for natural gas used at the processing facility is therefore \$2.10M or 0.40 \$/t milled.

#### 21.2.4.7 External Assays

The Horne 5 processing plant will not include a chemical laboratory for analysis of the samples collected for metallurgical accounting, on-stream analyzer calibration or development testwork. The samples collected include slurries from various stages of the flowsheet or the metallurgical laboratory; both high and low grade solution samples, carbon, bullion and slag. A quotation for unit assay costs for each type of sample was obtained by Falco from a local accredited laboratory.

Based on the estimated sample collection frequency and the budgetary quotation, an annual average cost of \$0.82M, or 0.15 \$/t milled, was calculated for external assay requirements.

#### 21.2.4.8 Rail spur maintenance and snow removal

An estimate of \$0.6M per full production year was provided by a specialized contractor to cover the cost of a regular preventive maintenance program and snow clearing during the winter, ensuring a safe and efficient operation of the rail spur located at the Horne 5 Mining Complex. This is equivalent to 0.10 \$/t over the LOM.

#### 21.2.4.9 Special projects

An allowance of \$0.5M per year was made for special projects realized to enhance the metallurgical performance or maintainability of the processing facility. These include plant audits, circuit optimization work, reagent testing, wear material trials, etc. This amount translates into 0.09 \$/t over the LOM.

### 21.2.5 Tailings, Water Treatment and Environment

The paste backfill plant, surface water management, water treatment, tailings management facility operating costs and environmental services operating costs were based on feasibility level estimates provided by WSP, Golder and Falco. The operating costs were determined to be approximately \$411.3M over the LOM or 5.08 \$/t milled.

This area includes the following operating costs:

- Paste Backfill Plant operations, maintenance and consumables (provided by WSP);
- Pipeline and pumping operations and maintenance (provided by Golder);
- Water treatment plant operations, maintenance and consumables (provided by Golder);
- Tailings management facility; including TMF surface work management operating costs and labour (provided by Falco);
- Environmental services group labour costs and associated expenses (provided by Falco) such as:
  - Recycling and waste disposal fees;
  - Permitting costs;
  - Equipment rental;
  - Sampling and analytical fees;
  - Consulting and contract services.

A breakdown of the steady-state costs, without contingency, is presented in Table 21-35.

Table 21-35: Tailings, water treatment and environment operating cost summary

Cost Area	Annual Cost (\$M/year) <sup>(1)</sup>	Cost per tonne milled (\$/t)	Percentage of OPEX (%) <sup>(2)</sup>
Paste Backfill Plant	20.1	3.35	66
Pipelines and Pumping	1.6	0.25	5
Water Treatment	2.8	0.48	9
Tailings Management Facility and Water Management	3.5	0.56	11
Environmental Services	2.5	0.44	9
<b>Total</b>	<b>30.5</b>	<b>5.08</b>	<b>100</b>

<sup>(1)</sup> Based on a representative year during Mine Phase 1 with TMF.

<sup>(2)</sup> Based on cost per tonne milled.

### 21.2.6 General and Administration

G&A costs are expenses not directly related to the production of goods and encompass items not included in the mining, processing, refining, and transportation costs of the Project. These costs were developed based on Falco's past project experience, similar sized operations, and BBA's in-house database.

The G&A area includes the following items:

- Site administration and management labour;
- Human Resources, Information Technology (“IT”) and Health Services labour;
- Mine and Geology Technical Services labour;
- Office furniture and supplies;
- Computer hardware and software costs/license fees;
- Electrical power and heating for site buildings other than the process plant;
- Health and Safety supplies;
- Building insurance (including loss of production);
- Security, maintenance, laundry, snow removal and janitorial service contracts;
- Warehouse administration and supplies;
- Waste collection and recycling services;
- Telecommunications and data service fees;
- Training;
- Municipal and school taxes.

The labour included in the G&A area includes 3 management employees, 18 administration (accounting, IT and warehousing) employees, 5 employees in human resources, 6 employees in health and safety, and 30 employees dedicated to technical services (engineering and geology). The employee total for the overall G&A services is 62.

In general, the management and administrative staff will work 40 hours per week on day shift. Warehousing personnel will work a 12-hour shift per day to support the 24 hours of required daily operations.

On an annual basis, the G&A costs are estimated to be 16.05 \$M/year or approximately \$231.4M over the LOM. The G&A cost on a per tonne milled basis is 2.86 \$/t milled (LOM).

The major costs broken down by item within the G&A category are shown in Table 21-36. The greatest cost within the G&A category is labour, representing approximately 42%, while insurance is the second greatest cost accounting for approximately 15%. Municipal and school taxes represent approximately 12% of the G&A costs.

Table 21-36: Average general and administrative costs

Item	Annual Cost (\$M/year)	Percentage of Total (%)
Labour	6.72	41.9
Association, Fees, and Sponsorships and Training	0.23	1.4
Office furniture and supplies	0.10	0.6
IT / Communication supplies and service fees	1.18	7.4
Consultants	0.35	2.2
Travel Expenses	0.05	0.3
Insurance	2.33	14.5
Electricity and Heating	0.31	1.9
Health and Safety Supplies	0.68	4.2
Other Service and Rental Fees	0.65	4.0
Building Maintenance	0.50	3.1
Laundry, Janitorial, Snow Removal and Security Service	1.08	6.7
Taxes (Municipal and School)	1.87	11.7
<b>Total</b>	<b>16.05</b>	<b>100</b>

### 21.2.7 Personnel Summary – All Areas

A total facility workforce of 496 employees is estimated for the Horne 5 Project prior to the construction of the surface TMF. A total of 14 employees will commence with the beginning of



operations at the surface TMF, 8 of which will transfer from the underground tailings service for a total of 502 employees for the remainder of the LOM. A summary of labour in all areas is shown in Table 21-37.

Table 21-37: Summary of personnel – all areas

Facility Area	Role	Total without TMF	Total with TMF
General & Administration	Management	3	3
	Administration	18	18
	Human Resources and Community Relations	5	5
	Health and Safety	6	6
	Technical Services (Mine and Geology)	30	30
	<b>Subtotal</b>	<b>62</b>	<b>62</b>
Underground Mine	Staff and Supervision	57	57
	Operations	136	136
	Maintenance and Services	140	132
	<b>Subtotal</b>	<b>333</b>	<b>325</b>
Process Plant	Staff and Supervision	35	35
	Operations	34	34
	Maintenance	20	20
	<b>Subtotal</b>	<b>89</b>	<b>89</b>
Paste Backfill Plant (Surface)	Staff and Supervision	-	-
	Operations	4	4
	Maintenance	-	-
	<b>Subtotal</b>	<b>4</b>	<b>4</b>
Tailings, Water Management and Environment	Staff and Supervision	8	10
	Operations	-	12
	Maintenance	-	-
	<b>Subtotal</b>	<b>8</b>	<b>22</b>
Horne 5 Mine Site	<b>Total</b>	<b>496</b>	<b>502</b>

## 22. ECONOMIC ANALYSIS

The economic/financial assessment of the Horne 5 Project for Falco was carried out using a discounted cash flow approach on a pre-tax and after-tax basis, based on consensus equity research long-term commodity price projections (as of October 2, 2017) in United States currency and cost estimates in Canadian currency. An exchange rate of 0.78 USD per 1.00 CAD was assumed to convert USD market price projections and particular components of the capital cost estimates into Canadian Dollars (“CAD”). No provision was made for the effects of inflation. Current Canadian tax regulations were applied to assess the corporate tax liabilities, while the most recent provincial regulations were applied to assess the Québec mining tax liabilities.

The internal rate of return (“IRR”) on total investment was calculated based on 100% equity financing, even though Falco may decide in the future to finance part of the Project with debt financing. The net present value (“NPV”) was calculated from the cash flow generated by the Project, based on a discount rate of 5%. The payback period, based on the undiscounted annual cash flow of the Project, is also indicated as a financial measure. Furthermore, a sensitivity analysis has been performed for the after-tax base case to assess the impact of variations in the Project capital costs, USD:CAD exchange rate, price of gold, and operating costs.

The economic analysis presented in this section contains forward-looking information with regard to the mineral reserve estimates, commodity prices, exchange rates, proposed mine production plan, projected recovery rates, operating costs, construction costs and Project schedule. The results of the economic analysis are subject to a number of known and unknown risks, uncertainties and other factors that may cause actual results to differ materially from those presented here.

Glencore Canada retains a 2% net smelter return royalty on all metals produced and has rights of first refusal with respect to purchase or toll process all or any portion of the concentrates and other mineral products.

### 22.1 Assumptions and Basis

The economic analysis was performed using the following assumptions and basis:

- The Project Executive Schedule developed in Chapter 24, taking into consideration key Project milestones;
- Commercial production start-up is scheduled to begin in third quarter (“Q3”) of 2021. The first full year of production is therefore 2022. Operations are estimated to span a period of approximately fifteen years;
- The base case gold, silver, copper and zinc prices are 1,300 USD/oz., 19.50 USD/oz., 3.00 USD/lb, and 1.10 USD/lb respectively;

- The long term prices of gold, silver, copper and zinc were estimated on the basis of discussions with experts, consensus analyst estimates and recently-published economic studies that were deemed to be credible (October 2,2017). The forecasts used are meant to reflect the average metal price expectation over the life of the Project. No price inflation or escalation factors were taken into account. It is understood that commodity prices can be volatile and that there is the potential for deviation from the LOM forecasts.
- The United States to Canadian dollar exchange rate has been assumed to be 0.78 USD: 1.00 CAD over the life of mine (CAD:USD exchange rate of 1.28);
- All cost estimates are in constant Q2 2017 Canadian dollars with no inflation or escalation factors taken into account;
- All metal products are assumed sold in the same year they are produced;
- Class specific Capital Cost Allowance rates are used for the purpose of determining the allowable taxable income;
- All Project related payments and disbursements incurred prior to the effective date of this Report are considered as sunk costs. Project capital cost disbursements as of August 31, 2017 are \$34.3M. Disbursements projected for after the effective date of this Report, but before the start of construction, are considered to take place in the preproduction period;
- Final rehabilitation and closure costs will be incurred in 2035 (Year 15);
- Project revenue is derived from the sale of concentrates and gold/silver doré into the international marketplace. No contractual arrangements for concentrate and doré smelting or refining exist at this time; however, preliminary market studies on the potential concentrate sales were completed to provide an indication of market smelter terms, as noted in Chapter 19.
- Glencore Canada retains a 2% net smelter return royalty on all metals produced and has rights of first refusal with respect to purchase or toll process all or any portion of the concentrates and other mineral products.

This financial analysis was performed on both a pre-tax basis and after-tax basis with the assistance of an external tax consultant. The general assumptions used for this financial model, LOM plan tonnage and grade estimates are summarized in Table 22-1, and are outlined in Table 22-2.

**Table 22-1: Financial model parameters**

Description	Unit	Value
Long Term Gold Price	USD/oz	1,300
Long Term Silver Price	USD/oz	19.50
Long Term Copper Price	USD/lb	3.00
Long Term Zinc Price	USD/lb	1.10
Exchange Rate	USD:CAD	0.78

Description	Unit	Value
Discount Rate	%	5
Mine Life	year	15
Total Mined and Milled	tonne	80,896,876
Gold Grade	g/t	1.44
Silver Grade	g/t	14.14
Copper Grade	%	0.17
Zinc Grade	%	0.77
Average Annual Gold Production (Steady State)	Au oz per year	235,000
Average Annual Payable Gold Production	Au oz per year	219,462
Underground Mining Operating Cost	\$/t milled	12.60
Processing Operating Cost	\$/t milled	20.45
Tailings and Water Management Operating Cost	\$/t milled	5.08
General and Administration Operating Cost	\$/t milled	2.86
All-in Sustaining Costs ("AISC")	USD/oz	399
Royalties	% NSR	2
Preproduction Capital Cost (less outlays as of August 31, 2017)	\$M	1,027.8
Sustaining Capital Cost	\$M	535.4
Reclamation and Closure Cost	\$M	87.2
Salvage Value	\$M	45

## 22.2 Gold Production

Over the life of mine, a total of 3.294 Moz of gold (Payable) (Average annual: 219,462 oz) will be produced. Figure 22-1 provides a summary of the payable gold production by year.

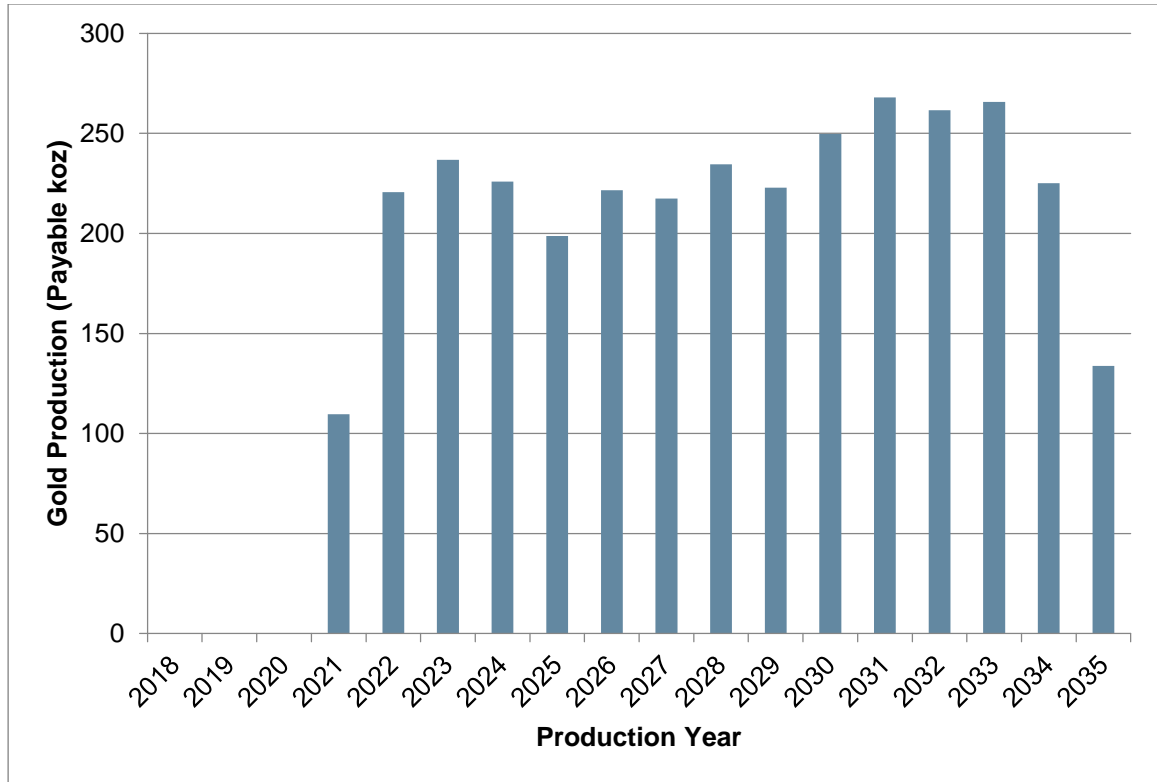

Figure 22-1: Annual Payable Gold Production (koz)

### 22.3 Capital and Sustaining Costs

All capital costs (preproduction, sustaining, reclamation and closure) for the Project have been distributed against the development schedule to support the economic cash flow model. Figure 22-2 presents the planned annual and cumulative LOM capital cost profile, excluding sunk costs.

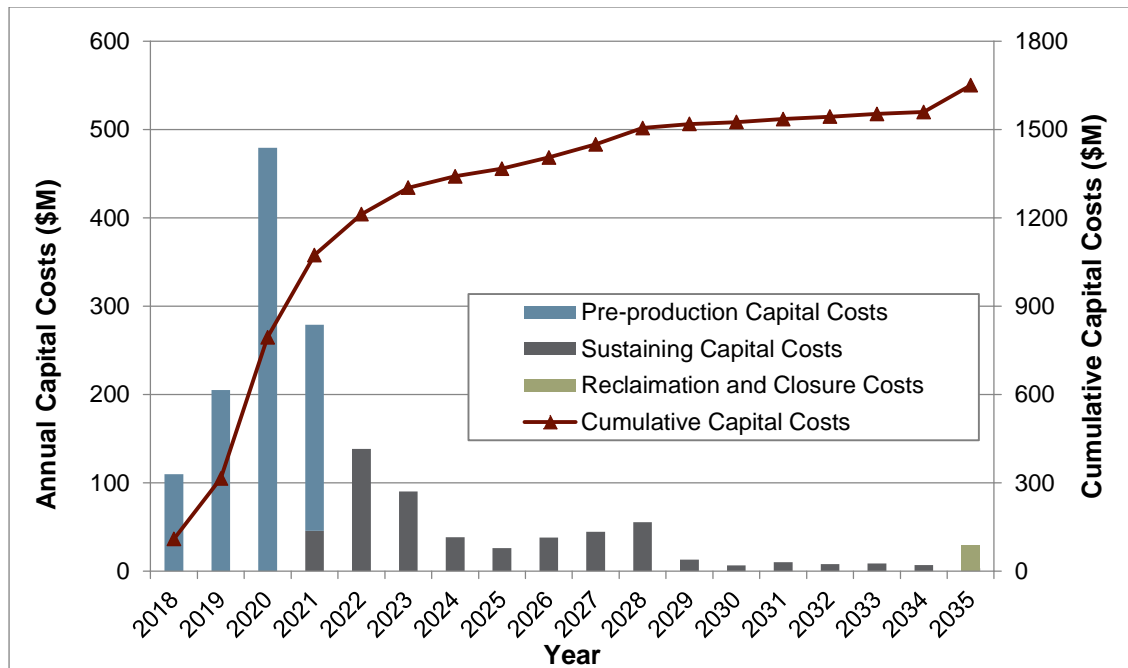

Figure 22-2: Overall Horne 5 Project capital cost profile

## 22.4 Royalties

Over the life of the Project, approximately \$157M in royalties is expected to be paid based on the base case metal prices and Project assumptions. These royalties are based on a 2% NSR, payable to Glencore Canada.

## 22.5 Taxation

The Horne 5 Project is subject to three levels of taxation, including federal income tax, provincial income tax, and provincial mining taxes. Falco compiled the taxation calculations for the Horne 5 Project with assistance from third-party taxation experts; however, this information was not verified by Colin Hardie, QP.

The current Canadian tax system applicable to Mineral Resource Income was used to assess the annual tax liabilities for the Project. This consists of federal and provincial corporate taxes, as well as provincial mining taxes. The federal corporate tax currently applicable over the operating life of the Project is 15.0% of taxable income while the provincial corporate tax is 11.7% (2018), 11.6% (2019) and 11.5% (2020 and on). The marginal tax rates applicable under the recently proposed mining tax regulations in Québec (Bill 55, December 2013) are 16%, 22% and 28% of taxable income and are dependent on the profit margin. It has been assumed that the 10% processing

allowance rate associated with transformation of the mine product to a more advanced stage within the province would be applicable in this instance.

The tax calculations are underpinned by the following key assumptions:

- The Project is held 100% by a corporate entity and the after-tax analysis does not attempt to reflect any future changes in corporate structure or property ownership;
- Assumes 100% equity financing and therefore does not consider interest and financing expenses;
- Payments projected relating to NSR royalties are allowed as a deduction for federal and provincial income tax purposes, but are added back for provincial mining tax purposes;
- Actual taxes payable will be affected by corporate activities, and current and future tax benefits have not been considered.

The combined effect on the Project of the three levels of taxation, including the elements described above, is an approximate cumulative effective tax rate of 36%, based on Project Earnings. It is anticipated, based on the Project assumptions, that Falco will pay approximately \$1,006M in tax payments over the life of the Project.

## 22.6 Financial Analysis Summary

A 5% discount rate was applied to the cash flow to derive the NPV for the Project on a pre-tax and after-tax basis. Cash flows have been discounted to Q1 2018 under the assumption that major Project financing would be carried out at this time. The summary of the financial evaluation for the base case of the Project is presented in Table 22-2.

Table 22-2: Financial analysis summary (pre-tax and after-tax)

Description		Unit	Base Case
Pre-Tax	Net Present Value (0% disc)	\$M	2,772.3
	Net Present Value (5% disc)	\$M	1,297.1
	Internal Rate of Return	%	18.9
	Simple Payback Period	Years	5.2
After-Tax	Net Present Value (0% disc)	\$M	1,766.2
	Net Present Value (5% disc)	\$M	772.3
	Internal Rate of Return	%	15.3
	Simple Payback Period	Years	5.6



---

The pre-tax base case financial model resulted in an internal rate of return of 18.9% and a NPV of \$1,297M with a discount rate of 5%. The simple pre-tax payback period is 5.2 years. On an after-tax basis, the base case financial model resulted in an internal rate of return of 15.3% and a NPV of \$772M with a discount rate of 5%. The simple after-tax payback period is 5.6 years.

The summary of the Horne 5 Project discounted cash flow financial model (pre-tax and after-tax) is presented in Table 22-3.

Table 22-3: Horne 5 Project financial model summary

Year	-3 2018	-2 2019	-1 2020	1 2021	2 2022	3 2023	4 2024	5 2025	6 2026	7 2027	8 2028	9 2029	10 2030	11 2031	12 2032	13 2033	14 2034	15 2035	16 2036	Total
<b>Production Summary</b>																				
Total Tonnes Mined (kt)				2,774	5,867	5,821	5,852	5,828	5,842	5,527	5,673	5,721	5,775	5,797	5,796	5,770	5,654	3,199		<b>80,897</b>
Total Tonnes Milled (kt)				2,774	5,867	5,821	5,852	5,828	5,842	5,527	5,673	5,721	5,775	5,797	5,796	5,770	5,654	3,199		<b>80,897</b>
Mill Head Grade Au (g/t)				1.41	1.36	1.45	1.38	1.23	1.35	1.39	1.44	1.39	1.52	1.61	1.57	1.60	1.41	1.46		<b>1.44</b>
Mill Head Grade Ag (g/t)				16.05	15.24	11.44	14.67	15.62	15.33	15.07	13.33	15.77	15.02	13.69	14.16	13.32	12.60	9.77		<b>14.14</b>
Mill Head Grade Cu (%)				0.19%	0.16%	0.12%	0.13%	0.13%	0.16%	0.16%	0.13%	0.15%	0.22%	0.19%	0.22%	0.23%	0.18%	0.21%		<b>0.17%</b>
Mill Head Grade Zn (%)				1.00%	0.90%	0.69%	0.86%	0.92%	0.99%	0.91%	0.55%	0.89%	0.70%	0.60%	0.67%	0.66%	0.74%	0.55%		<b>0.77%</b>
Gold Production (koz)				111.4	223.7	239.6	228.8	201.1	224.7	220.5	237.4	226.0	253.7	272.0	265.6	270.0	228.5	135.9		<b>3,339</b>
Silver Production (koz)				1,088.0	2,148.1	1,556.8	2,033.8	2,155.3	2,160.6	2,005.5	1,765.2	2,166.2	2,118.1	1,917.4	2,001.7	1,877.3	1,723.2	758.4		<b>27,476</b>
Copper Production (M lbs)				9.9	16.3	11.7	13.1	12.4	16.6	15.8	12.0	15.4	23.6	20.5	23.8	24.6	19.1	12.4		<b>247.3</b>
Zinc Production (M lbs)				54.3	102.1	75.3	96.7	103.8	112.6	97.1	55.8	98.8	75.6	63.3	72.8	71.2	79.0	31.5		<b>1,189.8</b>
Payable Gold (koz)				111.0	225.5	238.1	228.9	202.8	223.5	218.1	231.9	224.4	248.4	263.5	258.4	261.9	225.2	132.4		<b>3,294.2</b>
Payable Silver (koz)				1,023.2	2,055.8	1,531.2	1,973.8	2,092.9	2,058.3	1,914.3	1,738.3	2,073.8	1,994.4	1,823.9	1,886.8	1,767.3	1,637.4	718.5		<b>26,289.9</b>
Payable Copper (M lbs)				8.9	15.3	11.8	12.9	12.3	15.5	14.7	12.0	14.6	21.0	18.5	21.1	21.8	17.4	11.0		<b>228.7</b>
Payable Zinc (M lbs)				44.6	84.7	64.7	80.6	85.9	92.7	80.5	50.4	82.0	64.8	56.0	62.8	61.6	67.1	28.4		<b>1,006.8</b>
<b>Revenue</b>																				
Exchange Rate (USD:CAD)	1.28	1.28	1.28	1.28	1.28	1.28	1.28	1.28	1.28	1.28	1.28	1.28	1.28	1.28	1.28	1.28	1.28	1.28		<b>1.28</b>
Gross Revenue (\$M)				283.0	552.0	528.7	544.4	506.1	563.6	537.5	514.1	550.8	597.5	603.5	612.3	617.6	537.5	302.7		<b>7,851.2</b>
<b>Operating Expenditures</b>																				
Mining (\$M)				41.6	69.9	71.1	70.4	69.8	71.7	67.1	68.8	74.0	77.4	76.4	74.1	72.1	68.9	46.4		<b>1,019.6</b>
Processing (\$M)				57.3	121.0	118.8	119.5	118.3	118.8	114.5	114.4	117.3	118.4	117.4	118.1	117.7	116.4	66.3		<b>1,654.3</b>
Environment & Tailings (\$M)				12.8	23.6	30.1	30.2	30.8	30.6	29.1	28.8	29.0	29.2	29.4	29.5	29.4	29.0	19.6		<b>411.3</b>
General & Administration (\$M)				6.7	16.1	16.1	16.1	16.1	16.1	16.1	16.1	16.1	16.1	16.1	16.1	16.1	16.1	16.1		<b>231.4</b>
<b>Onsite Operating Costs (\$M)</b>				<b>118.4</b>	<b>230.5</b>	<b>236.1</b>	<b>236.2</b>	<b>235.0</b>	<b>237.1</b>	<b>226.8</b>	<b>228.0</b>	<b>236.5</b>	<b>241.1</b>	<b>239.3</b>	<b>237.8</b>	<b>235.3</b>	<b>230.3</b>	<b>148.3</b>		<b>3,316.5</b>
Royalty Payments (\$M)				5.7	11.0	10.6	10.9	10.1	11.3	10.7	10.3	11.0	11.9	12.1	12.2	12.4	10.7	6.1		<b>157.0</b>
<b>Capital Expenditures</b>																				
Preproduction (\$M)	110.0	205.2	479.6	233.1																<b>1,027.8</b>
Sustaining (\$M)				45.9	138.4	90.4	38.4	26.3	38.1	44.6	55.4	13.3	6.6	10.3	8.3	9.0	7.0	3.3		<b>535.4</b>
Reclamation and Closure (\$M)																		87.2		<b>87.2</b>
Salvage Value (\$M)																		(45.0)		<b>(45.0)</b>
<b>Total Capital Costs (\$M)</b>	<b>110.0</b>	<b>205.2</b>	<b>479.6</b>	<b>279.0</b>	<b>138.4</b>	<b>90.4</b>	<b>38.4</b>	<b>26.3</b>	<b>38.1</b>	<b>44.6</b>	<b>55.4</b>	<b>13.3</b>	<b>6.6</b>	<b>10.3</b>	<b>8.3</b>	<b>9.0</b>	<b>7.0</b>	<b>45.4</b>		<b>1,605.4</b>
Changes in Working Capital (\$M)	0	0	0	(2.3)	(2.2)	0.2	(0.1)	0.3	(0.5)	0.2	0.2	(0.3)	(0.4)	0.0	(0.1)	0.0	0.7	1.9	2.5	-
<b>Pre-Tax Cash Flow</b>																				
Pre-Tax Cash flow (\$M)	(110.0)	(205.2)	(479.6)	(122.4)	169.7	191.8	258.8	235.0	276.7	255.5	220.6	289.8	337.5	341.8	353.9	361.0	290.1	104.8	2.5	<b>2,772.3</b>
<b>Cumulative Pre-Tax Cash Flow (\$M)</b>	<b>(110.0)</b>	<b>(315.2)</b>	<b>(794.8)</b>	<b>(917.1)</b>	<b>(747.4)</b>	<b>(555.6)</b>	<b>(296.8)</b>	<b>(61.8)</b>	<b>214.8</b>	<b>470.3</b>	<b>690.9</b>	<b>980.6</b>	<b>1,318.1</b>	<b>1,659.9</b>	<b>2,013.8</b>	<b>2,374.8</b>	<b>2,664.9</b>	<b>2,769.8</b>	<b>2,772.3</b>	

Year	-3	-2	-1	1	2	3	4	5	6	7	8	9	10	11	12	13	14	15	16	Total
	2018	2019	2020	2021	2022	2023	2024	2025	2026	2027	2028	2029	2030	2031	2032	2033	2034	2035	2036	
<b>Taxes and Duties</b>																				
Federal Corporate Income Tax (\$M)							11.0	17.8	27.6	27.3	25.4	30.7	37.4	39.6	41.8	43.3	35.1	17.6	(11.7)	<b>342.9</b>
Provincial Corporate Income Tax (\$M)								12.7	22.0	20.7	19.0	25.6	30.4	31.7	33.0	33.9	27.5	13.7	(8.5)	<b>261.9</b>
Québec Mining Duties (\$M)	(6.2)	(15.6)	(19.9)	3.5	7.5	8.0	12.6	18.3	30.7	30.4	27.4	36.0	47.3	50.8	54.4	57.5	42.9	15.6	-	<b>401.2</b>
<b>Total Taxes and Duties (\$M)</b>	<b>(6.2)</b>	<b>(15.6)</b>	<b>(19.9)</b>	<b>3.5</b>	<b>7.5</b>	<b>8.0</b>	<b>23.6</b>	<b>48.8</b>	<b>80.3</b>	<b>78.4</b>	<b>71.8</b>	<b>92.4</b>	<b>115.2</b>	<b>122.2</b>	<b>129.2</b>	<b>134.8</b>	<b>105.5</b>	<b>46.9</b>	<b>(20.2)</b>	<b>1,006.0</b>
<b>After-Tax Cash Flow</b>																				
After-Tax Cash flow (\$M)	(103.9)	(189.5)	(459.7)	(125.8)	162.3	183.8	235.1	186.2	196.4	177.0	148.8	197.4	222.3	219.6	224.7	226.2	184.6	58.0	22.7	<b>1,766.2</b>
<b>Cumulative After-Tax Cash Flow (\$M)</b>	<b>(103.9)</b>	<b>(293.4)</b>	<b>(753.1)</b>	<b>(878.9)</b>	<b>(716.7)</b>	<b>(532.8)</b>	<b>(297.7)</b>	<b>(111.5)</b>	<b>84.9</b>	<b>261.9</b>	<b>410.7</b>	<b>608.1</b>	<b>830.4</b>	<b>1,050.0</b>	<b>1,274.7</b>	<b>1,501.0</b>	<b>1,685.5</b>	<b>1,743.5</b>	<b>1,766.2</b>	
<b>Pre-Tax Summary</b>																				
Non-Discounted Cash Flow (\$M)	2,772.3																			
Pre-Tax NPV @ 5% (\$M)	1,297.1																			
Pre-Tax IRR (%)	18.9																			
Simple Payback (years)	5.2																			
<b>After-Tax Summary</b>																				
Non-Discounted Cash Flow (\$M)	1,766.2																			
After-Tax NPV @ 5% (\$M)	772.3																			
After-Tax IRR (%)	15.3																			
Simple Payback (years)	5.6																			

Figure 22-3 shows the cumulative cash flows for the Project projected for the life of the mine on a pre-tax and after-tax basis.

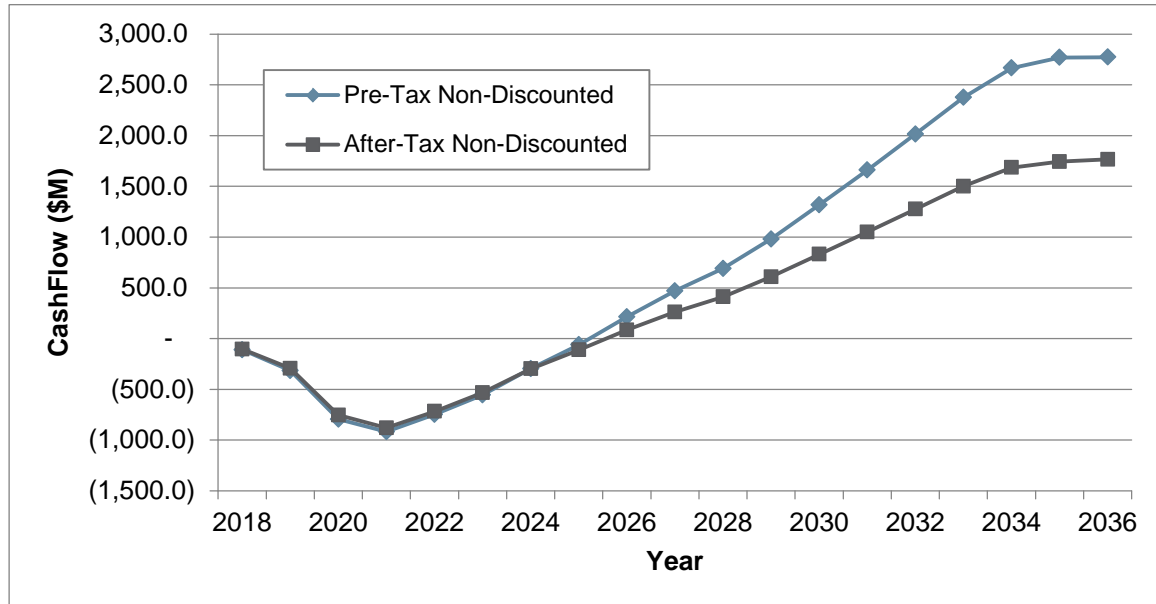

Figure 22-3: Life of mine cash flow projection (cumulative, pre-tax and after-tax)

## 22.7 Production Costs

A summary of the Project’s production costs is provided in Table 22-4. All costs are in USD. Total cash costs are calculated per ounce on a payable basis using the costs of mining, processing, tailings and water treatment, on-site G&A, refining and smelting, transport, and royalties. A credit for by-product revenues is then applied.

The LOM operating cash cost per ounce (Including by-product credits) is 260 USD/oz Au. The LOM cost all-in sustaining cost (“AISC”<sup>1</sup>) per ounce is 399 USD/oz Au derived from the total cash costs plus sustaining capital, and closure costs. The operating margin over the LOM has been estimated to be 901 USD/oz Au based on a gold price of 1,300 USD/oz.

<sup>1</sup> All-in Sustaining Costs are presented as defined by the World Gold Council (“WGC”) less Corporate G&A

Table 22-4: Production cost summary

Description	Unit	LOM
<b>Metal Production</b>		
Gold (Payable)	Moz	3.29
Silver (Payable)	Moz	26.3
Copper (Payable)	Mlb	229
Zinc (Payable)	Mlb	1,007
<b>Costs, Royalties and Credits</b>		
Mining	USD M	795.3
Processing	USD M	1,290.3
Tailings and Water Management	USD M	320.8
General and Administration	USD M	180.5
Refining and Smelting	USD M	493.5
Royalties	USD M	122.5
By-Product Credit	USD M	(2,337.9)
Total Operating Cost (after Credit)	USD M	865
<b>AISC Costs and Profit Margins (per oz payable)</b>		
Gold Price	USD/oz	1,300
Cash Cost (Operating)	USD/oz	260
Sustaining and Closure Costs	USD M	450.6
Total Costs (Operating and Sustaining)	USD M	1,315.4
AISC Costs <sup>(1)</sup>	USD/oz	399
Operating Margin	USD/oz	901

<sup>(1)</sup> As defined by the World Gold Council less corporate G&A costs.

## 22.8 Sensitivity Analysis

A financial sensitivity analysis was conducted on the base case after-tax cash flow NPV and IRR of the Project, using the following variables: capital costs, operating costs, USD:CAD exchange rate, price of gold and discount rate. The after-tax results for the Project IRR and NPV based on the sensitivity analysis are summarized in Table 22-5 through Table 22-9.

Table 22-5: NPV sensitivity results (after-tax) for metal price and exchange rate variations

USD:CAD	Gold Price (USD/ounce)						
	1,000	1,100	1,200	1,300	1,400	1,500	1,600
0.88	18.6	167.2	308.8	448.6	586.2	719.7	851.5
0.85	101.6	251.3	396.1	539.8	679.2	816.3	951.1
0.81	218.7	370.7	522.1	668.6	812.6	954.1	1,094.5
0.78	310.5	468.2	622.3	772.3	920.0	1,066.0	1,210.6
0.75	409.6	572.0	728.7	883.0	1,035.1	1,185.8	1,335.8
0.72	516.6	681.2	842.7	1,001.7	1,158.9	1,315.1	1,470.0
0.70	591.1	758.6	923.4	1,085.9	1,246.8	1,406.8	1,565.7

Table 22-6: IRR sensitivity results (after-tax) for metal price and exchange rate variations

USD:CAD	Gold Price (USD/ounce)						
	1,000	1,100	1,200	1,300	1,400	1,500	1,600
0.88	5.3%	7.4%	9.4%	11.3%	13.0%	14.7%	16.2%
0.85	6.5%	8.6%	10.6%	12.5%	14.2%	15.8%	17.4%
0.81	8.2%	10.3%	12.2%	14.1%	15.8%	17.4%	19.0%
0.78	9.4%	11.6%	13.5%	15.3%	17.1%	18.7%	20.3%
0.75	10.8%	12.9%	14.8%	16.7%	18.4%	20.0%	21.6%
0.72	12.2%	14.3%	16.2%	18.0%	19.7%	21.4%	23.0%
0.70	13.2%	15.2%	17.1%	19.0%	20.7%	22.3%	23.9%

Table 22-7: NPV sensitivity results (after-tax) for operating and capital cost variations

CAPEX	OPEX						
	-30%	-20%	-10%	0%	10%	20%	30%
-30%	1,501.0	1,386.4	1,270.8	1,152.9	1,032.0	908.5	780.9
-20%	1,374.2	1,259.5	1,144.0	1,026.1	905.1	781.7	654.1
-10%	1,247.3	1,132.7	1,017.1	899.2	778.2	654.8	527.2
0%	1,120.4	1,005.8	890.2	772.3	651.4	527.9	400.3
10%	993.5	878.9	763.4	645.5	524.5	401.0	273.5
20%	866.7	752.1	636.5	518.6	397.6	274.2	146.6
30%	739.8	625.2	509.6	391.7	270.8	147.3	19.7

**Table 22-8: IRR sensitivity results (after-tax) for operating and capital cost variations**

CAPEX	OPEX						
	-30%	-20%	-10%	0%	10%	20%	30%
-30%	30.7%	29.0%	27.3%	25.5%	23.6%	21.6%	19.4%
-20%	26.1%	24.6%	23.0%	21.4%	19.7%	17.8%	15.9%
-10%	22.5%	21.0%	19.6%	18.1%	16.5%	14.8%	13.0%
0%	19.4%	18.1%	16.8%	15.3%	13.9%	12.3%	10.6%
10%	16.9%	15.6%	14.4%	13.0%	11.6%	10.1%	8.6%
20%	14.7%	13.5%	12.3%	11.0%	9.7%	8.3%	6.8%
30%	12.8%	11.6%	10.5%	9.3%	8.0%	6.7%	5.2%

**Table 22-9: NPV sensitivity results (after-tax) for discount rate**

NPV	Discount Rate						
	0%	3%	5%	7%	9%	11%	13%
NPV	1,766.20	1,088.80	772.3	531.6	347.5	206	96.9

The graphical representations of the financial sensitivity analysis are depicted below in Figure 22-4 for the Project's NPV and Figure 22-5 for the Project's IRR.

The sensitivity analysis reveals that the USD:CAD exchange rate has the most significant influence on both NPV and IRR compared to the other parameters, based on the range of values evaluated.

After the USD:CAD exchange rate, NPV was most impacted by changes in the gold price and then to a lesser but equal extent by variations in operating costs and capital costs. It should be noted that the economic viability of the Project will not be significantly negatively impacted by variations in the capital cost, within the margins of error associated with the capital cost estimate.

After the USD:CAD exchange rate, the Horne 5 Project's IRR was most impacted by variations in the capital cost and to a lesser extent by variations in gold price, followed by the operating costs.

Overall, the NPV and IRR of the Horne 5 Project are positive over the range of values used for the sensitivity analysis.



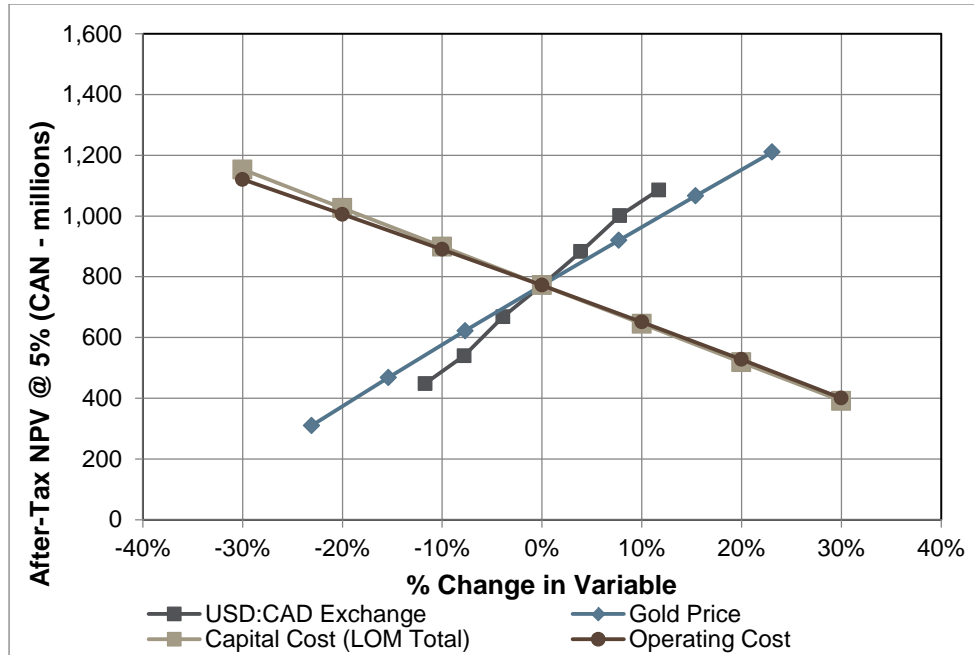

Figure 22-4: Sensitivity of the net present value (after-tax) to financial variables

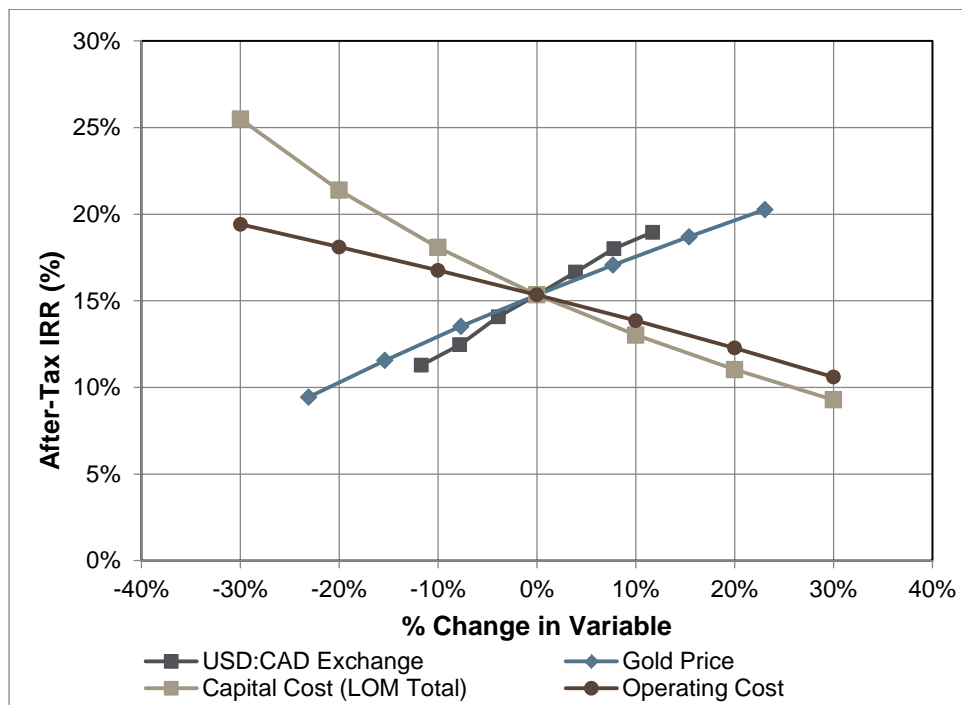

Figure 22-5: Sensitivity of the internal rate of return (after-tax) to financial variables

## 23. ADJACENT PROPERTIES

Falco maintains a significant land position in the Rouyn-Noranda mining camp (see Figure 4-2). Most of the historical mineral deposits of the camp are located on various parts of the Falco Property (also referred to as the "Rouyn-Noranda Project" in some company documents and in Figure 23-1). The producers and mineralized occurrences found on or within a few kilometres of the Concession are also shown in Figure 23-1.

Although a considerable amount of historical exploration and mining work has been carried out around the Concession hosting the Horne mine, there is no information on these properties that is relevant to the Horne 5 deposit.

In the present Report, the adjacent properties are defined as follows (Figure 23-1):

- For the upper 200 m of the Concession (from surface to a depth of 200 m), the Third Party owns 100% of the mining rights to the Concession (including the rights to minerals). The significant information from this property is presented in Chapters 6 and 7.
- All adjacent mining titles that surround the Concession are as follows:
  - Six mining concessions that are part of the "Horne Mines Ltd Controlled Properties" (the "Controlled Properties"): CM-148, CM-163PTA, CM-171, CM-235, CM-243 and CM-372. These concessions surround the Concession and are held by the Third Party. Pursuant to an agreement with the Third Party, Falco owns the rights to minerals contained at depths of more than 200 m below the surface on the Controlled Properties, and the Third Party owns 100% of the mining rights to the Concession, including the rights to minerals from the surface to a depth of 200 m;
  - The "Joliet Property" (CDC 1124511; also part of the Controlled Properties) is under agreement with the Third Party. Falco understands that should the CDC 1124511 be converted into a mining lease, Falco would own the rights to minerals contained at a depth of more than 200 m below the surface, and the Third Party would own 100% of the mining rights to the mining lease, including the rights to minerals from the surface to a depth of 200 m;
  - Two mining concessions, CM-0247PTA and CM-247PTB, are part of the Controlled Properties under agreement with the Third Party and subject to a joint venture agreement between such Third Party and Cambior (now IAMGOLD Corporation ("IAMGOLD")). As mentioned above, Falco understands, but is unable to confirm at this time, that it owns the Third Party's share of the minerals contained at a depth of more than 200 m below the surface on said two mining concessions. The joint venture partners own 100% of the mining rights to the concessions, including the rights to minerals from the surface to a depth of 200 m. IAMGOLD also retains the rights to its share of the minerals contained at a depth of more than 200 m below surface;

- Claims CL-4177931 and CL-4177932, are part of a property owned by Mines d'Argent Écu (formerly Société Minière Écudor);
- Claim CLD-P154010, is part of a property owned by Visible Gold Mines Ltd.;
- Mining concession CM-159, is part of a property owned by Resources NSR Inc.
- Five former operating mines are found on the adjacent properties described above: Horne (CM-156PTB), Chadbourne (CM-148), Quemont (CM-243), Joliet (CDC 1124511), and Don Rouyn (CM-235). These are discussed in the following sections and shown on Figure 23-1.

### 23.1 Horne Mine

Refer to Chapters 6 and 7.

### 23.2 Chadbourne Mine

The first of the former mines around the Concession to have been in operation was the Chadbourne Mine, located about 1.5 km southwest of the Horne smelter. In September of 1922, a prospector named Powel found a gold-bearing quartz vein near Rosebury Lake. The property was claimed for the Thompson-Chadbourne Syndicate. After trenching and sampling, Noranda relinquished its option to Powell-Rouyn Gold Mines Ltd. In September of 1923, a first shaft was sunk on the claims. On July 12, 1924, work was stopped at Chadbourne as the Horne mine had just been found. It was not until 1936 that the first mining operations started at Chadbourne. From 1936 to 1938, 30,994 short tons were extracted for a total of 2,128 ounces of gold. The mine reopened in the summer of 1976 and apparently extracted another 26,652 short tons of ore for an additional 1,563 ounces of gold (Bancroft and Atkinson, 1987; Gibson et al., 2001). The SIGEOM database reports a production period from 1976 to 1986, with a total of 1,427,000 tonnes of ore at a grade 3.65 g/t Au.

The host rocks are rhyolitic, andesitic and dioritic. Mineralization is interpreted to occur in a breccia caused by a phreatic explosion and filled by exhalative hydrothermalism. The major minerals associated with the breccia filling are carbonates, quartz, sericite, magnetite and gold-bearing pyrite. Mineralization appears as massive to disseminated sulphides (pyrite, chalcopyrite and galena) carrying gold and silver. The main alteration minerals are carbonates, silica and sericite.

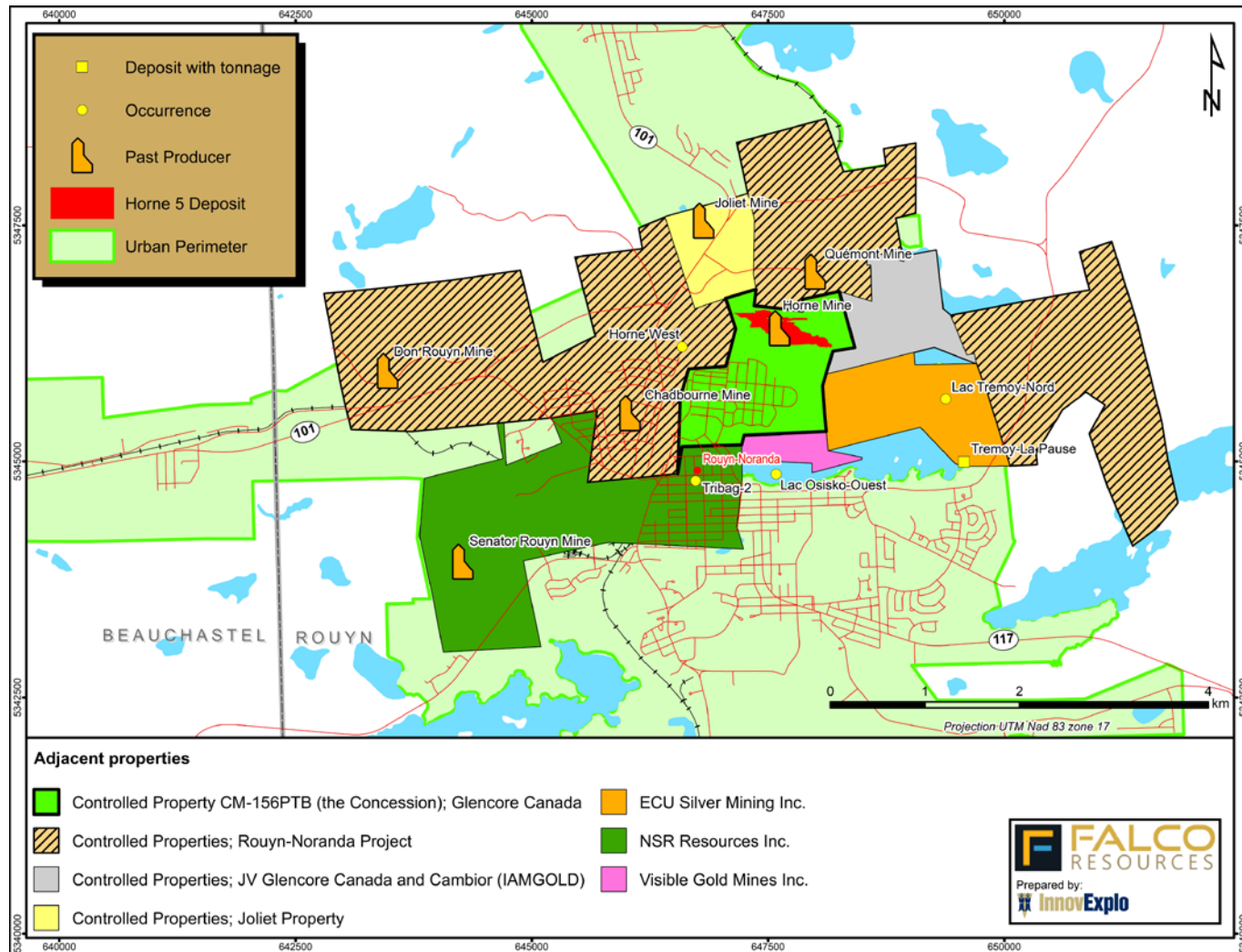

Figure 23-1: Adjacent properties to the Horne 5 deposit

### 23.3 Quemont Mine

The next mine to come into production was Quemont, just a few hundred metres north of the Horne mine. The Quemont claim was staked in 1922. In 1926, the Victoria Syndicate acquired the rights and carried out trenching and drilling. Later that year, the mining rights were transferred to United Verde Extension Company based in Arizona, which proceeded to sink shaft No. 1 to 235 ft, develop 300 ft of drifts at level 215 ft, and drill 6,000 ft. They found a small silica-rich gold zone. United Verde abandoned its option. In 1928, Mining Corporation of Canada acquired 90% of the rights and formed Quemont Mining Corporation. After an electrical survey, they deepened the shaft to 922 ft with stations at the 500 ft and 900 ft levels, and excavated 800 ft of drifts. They then drilled 3,000 ft with no encouraging results.

Exploration stopped until March of 1944 when a magnetic survey identified magnetic anomalies on the southern part of the claim. Drill hole No. 10 targeted an anomaly lying at the junction of the Horne Creek and Donald faults, and passed through 141 ft of massive sulphide just north of the Horne Creek Fault (Ingham et al., 1949). By 1949, reserves stood at 9 million short tons grading 1.52% Cu, 0.17 oz/t Au, 0.92 oz/t Ag and 2.69% Zn.

***These “reserves” are historical in nature and should not be relied upon. It is unlikely they comply with current NI 43-101 criteria or CIM Standards and Definitions, and they have not been verified to determine their relevance or reliability. They are included in this section for illustrative purposes only and should not be disclosed out of context. InnovExplo did not review the database, key assumptions, parameters or methods used for this estimate.***

The main shaft was sunk between 1947 and 1949. Historical production from 1949 to 1971 amounted to 15,348,973 short tons of Quemont ore yielding 1,918,300 ounces of gold, 184,800 short tons of copper, 280,300 short tons of zinc, and 7,941,700 ounces of silver (Bancroft and Atkinson, 1987a; Cattalini et al., 1993; Gibson et al., 2001).

The VMS sulphide bodies of the Quemont mine were situated in the upper part of a rhyolitic breccia horizon, below a massive rhyolite flow. The lenses consisted of chalcopyrite and pyrrhotite at their base, overlain by pyrite and sphalerite. A massive chalcopyrite halo surrounded the lenses, and was thicker at the base where gold and silver grades were generally higher. Important concentrations of disseminated sulphides were found in highly chloritized zones underlying the lenses.

The higher zinc grades and the strong and extensive chloritization associated with the disseminated sulphides at Quemont were different from the Horne mine setting (Cattalini et al., 1993).

## 23.4 Joliet Mine

The Joliet deposit was mined from 1952 to 1959 and again from 1961 to 1974 for its copper-gold-rich silica flux. According to the Cogite database, 2,080,000 tonnes were extracted to produce about 20,000 tonnes of copper. Cogite production records state grades of 0.91% Cu, 0.34 g/t Au and 72.0% SiO<sub>2</sub>. Bancroft and Atkinson (1987) collected data that supports a total of 1,615,639 short tons from 1951 to 1973, and a production of 12,117 short tons of copper. The former mine lies about 1 km northwest of the Horne smelting complex. A 1.4-km hauling drift linked the Joliet-Québec shaft to the Horne No. 4 shaft on level 970.

Host rocks around the deposit consist of massive to tuffaceous rhyolites intruded by numerous quartz or feldspar porphyry dikes and gabbro-dioritic dikes and sills. The Joliet deposit lies within tuffaceous rhyolite breccias. The breccias are chloritized, highly siliceous and carry variable amounts of chalcopyrite. The overall pipe-like body had a diameter of about 50 m and plunged steeply southwest (Harquail, 1952a; 1952b). The mined material was used as low-grade copper silica flux at the Horne smelting plant.

## 23.5 Don Rouyn Mine

The Don Rouyn mine was exploited from 1956 to 1976 as a copper-rich silica flux for the Horne smelting plant. It is located 4 km west of the Horne complex. A total of 5,248,928 short tons of ore were mined, from which 5,058 short tons of copper were produced (Bancroft and Atkinson, 1987).

The mined deposit is situated in the Powel trondhjemitic intrusion. It is considered to be a low-grade copper-gold-molybdenum porphyry-type deposit. Pyrite, chalcopyrite, bornite and molybdenite occur in disseminated form on the walls of fractures or in quartz-ankerite-calcite veins. Disseminated sulphides most commonly occur in or around chlorite blebs, whereas vein sulphides are usually embedded in quartz. Mineralogical zoning reveals a bornite-chalcopyrite core, a chalcopyrite-pyrite zone and finally a pyrite zone. Specularite increases in abundance outward (Goldie et al., 1979).

## 23.6 Horne West Occurrence

The Horne West occurrence is located 1.1 km west of the Horne mine. Historical exploration drilling on the Horne West occurrence yielded grades of 4.56 g/t Au over 14.63 m; 4.27 g/t Au over 9.32 m; 5.49 g/t Au over 20.63 m; and 3.37 g/t Au over 15.58 m. In addition, significant zinc mineralization was encountered in some of the drill holes (up to 4.83% Zn over 11.58 m). The volcanic succession of the area corresponds to the West 3913 member (see Section 7.2.2). The Horne West occurrence has been subdivided into two gold mineralized zones called the West Zone (northernmost) and the New Zone. The mineralized zones lie on mining concessions CM-148 and CM-171, just west of the Concession.

Mineralization in the Horne West occurrence shares many similarities with the Horne 5 deposit. Surface and subsurface mapping by Laurin (2010) suggests mineralization may have formed in a basin adjacent to a synvolcanic structure. The mineralization is characterized by sulphide veining and sulphide impregnations in aphyric rhyolite and associated volcanoclastic rocks. The gold-rich disseminated or stringer sulphide mineralization and associated alteration at Horne West formed in spatial and temporal association with seafloor massive sulphides that were the source of sulphide clasts in the volcanoclastic rocks (Laurin, 2010).

An exploration program by Xstrata Copper (now Glencore Canada) and Alexis Minerals (now QMX Gold Corporation) was initiated in late 2006 to evaluate the mineral potential of this gold occurrence. The best results from the program included 342 g/t Au over 1.0 m, 36.0 g/t Au over 1.0 m, 2.02 g/t Au over 36.4 m, 1.83% Zn over 9.7 m and 9.25 g/t Au over 2.1 m.

### 23.7 ECU Silver Mining Inc. Property

On the property owned by ECU Silver Mining Inc., most of the work conducted between 1927 and 1970 by Osisko Lake Mines Ltd consisted of drilling accompanied by trenching and sampling on the northwest peninsula of Lake Osisko. Some of these holes were drilled from underground drifts in the Horne mine, extending beneath the peninsula and the lake. The best values were 0.18 oz/t Au over 12.6 ft and 0.34 oz/t over 4.9 ft in holes 33-4772 and No. 7, respectively (Osisko Lake Mines Ltd, 1937 and 1947). In 1978 and 1979, magnetic and IP surveys were conducted by SOQUEM in the eastern part of the property. In 1983, magnetic and electromagnetic (VLF) surveys were done on the western part. Some trenches were excavated, yielding values of 0.04 to 0.22 oz/t Au in grab samples (Derome, 1982; Sicard-Lochon, 1989).

In 1985, Ressources La Pause Inc. (now Société Minière Écudor Inc.) acquired the property and performed an overall magnetic survey and a few IP tests. Drill holes at the time confirmed the presence of two known gold zones and discovered one new zone:

- Hole T-86-13: 0.14 oz/t Au over 0.40 m;
- Holes T-86-10 and T-86-11: several intercepts of 0.05 to 0.06 oz/t Au over 1 m;
- Holes T-86-16 and T-86-17: up to 0.2 oz/t Au over 1 m (the “Tremoy-LaPause” occurrence).

In 1986, the property was covered by a geological survey. Rocks displaying favourable gold-related alteration were identified. From December 1986 to March 1987, 25 drill holes confirmed the presence of gold mineralization and additional claims were acquired (Sicard-Lochon, 1989).

No recent work has been done on the claim adjacent to the Concession.



### 23.8 Visible Gold Mines Inc. Property

The Stadacona property belonging to Visible Gold Mines is located in the eastern part of the urban area of Rouyn Noranda and reaches Highway 117 in the airport area. Claim CLD-P154010 in the north part of this group of claims is adjacent to the Concession. It covers most of the western bay of Lake Osisko, just south of the western peninsula. Drill holes from 1937 and 1947 yielded low gold values under Lake Osisko. Hole No. 1 cut 0.01 oz/t Au over 2.5 ft and 0.02 oz/t Au over 2.5 ft, and hole No. 21 cut 0.02 oz/t over 5.0 ft (Osisko Lake Mines Ltd, 1937 and 1947). The SIGEOM database does not report any other diamond drill hole on this particular claim. Most of the work done by Visible Gold Mines on the Stadacona property was to explore and evaluate the eastern extensions of the former Stadacona Mine (2,740,000 short tons at 5.25 g/t Au from 1936 to 1958; Sansfaçon et al., 2011). An evaluation of possible historical reserves in areas 1 and 2 (by F. Viens of Cambior; July 27, 1988) stated a potential for 488,400 tonnes grading 6.3 g/t Au; these areas were located to the south of the mine and along branches of the Larder Lake-Cadillac Fault Zone (see the November 2007 MD&A of Visible Gold Mines).

***These “reserves” are historical in nature and should not be relied upon. It is unlikely they comply with current NI 43-101 criteria or CIM Standards and Definitions, and they have not been verified to determine their relevance or reliability. They are included in this section for illustrative purposes only and should not be disclosed out of context. InnovExplo did not review the database, key assumptions, parameters or methods used for this estimate.***

No recent work has been done on the claim adjacent to the Concession.

### 23.9 NSR Resources Inc. Property

NSR Resources Inc. (previously New Senator Rouyn, Bagamac Mines Ltd. and Tribag Mining Company Limited) owns the rights to a group of mining concessions just south of the Concession, of which mining concession CM-159 is adjacent to the Concession. The NSR Resources property is located within the urban limits of Rouyn-Noranda and extends from the approximate city centre westward to the mining concession of former producer New Senator Rouyn.

The mining concessions were claimed in 1926 by Bagamac Rouyn Mines Limited, a subsidiary of Bagamac Mines Limited of Ontario. In 1933, a shaft was sunk to 210 ft with a drift at level 200 ft to drill the New Senator mineralization. Production extended from 1940 to 1955, with 1,837,807 short tons mined at a grade of 0.13 oz/t Au (Ministère des Richesses Naturelles, 1967). In 1953, a drive was cut from the New Senator mine at the 2475 ft level to reach mining concession CM-159 and allow drilling under Noranda Lake (Jerome, 1954). Although favourable geology was identified, no significant amount of mineralization was found.

Further east on this property, two mineralized occurrences were found in the early years (Lee and Sutton, 1962):

- The “Tribag-2” gold occurrence:
  - Hole No. 61-4: 0.33 oz/t Au over 2.0 ft;
  - Hole No. 61-7: 0.38 oz/t Au over 3.0 ft.
- The “Lac Osisko-Ouest” gold occurrence:
  - Hole 62-10: 0.91 oz/t Au over 2.0 ft and 0.08 oz/t Au over 2.6 ft;
  - Hole 62-12: 0.1 oz/t Au over 1.5 ft.

No recent work has been done on the claim adjacent to the Concession.

### 23.10 Comments on Chapter 23

InnovExplo has been unable to verify the information provided herein on adjacent properties. The presence of significant mineralization on these adjacent properties is not necessarily indicative of similar mineralization on the Concession.

## 24. OTHER RELEVANT DATA AND INFORMATION

*Pursuant to an agreement between Falco and a Third Party, Falco owns rights to the minerals located below 200 metres from the surface of mining concession CM-156PTB, where the Horne 5 deposit is located. Falco also owns certain surface rights surrounding the Quemont No. 2 shaft located on mining concession CM-243. Under the agreement, ownership of the mining concessions remains with the Third Party.*

*In order to access the Horne 5 Project, Falco must obtain one or more licenses from the Third Party, which may not be unreasonably withheld, but which may be subject to conditions that the Third Party may require in its sole discretion. These conditions may include the provision of a performance bond or other assurance to the Third Party and the indemnification of the Third Party by Falco. The agreement with the Third Party stipulates, among other things, that a license shall be subject to reasonable conditions which may include, among other things, that activities at Horne 5 will be subordinated to the current use of the surface lands and subject to priority, as established in such party's sole discretion, over such activities. Any license may provide for, among other things, access to and the right to use the infrastructure owned by the Third Party, including the Quemont No. 2 shaft (located on mining concession CM-243 held by such Third Party) and some specific underground infrastructure in the former Quemont and Horne mines.*

*Furthermore, Falco will have to acquire a number of rights of ways or other surface rights in order to construct the TMF and associated pipelines.*

*While Falco believes that it should be able to timely obtain the licenses from the Third Party and to acquire the required rights of way and other surface rights, there can be no assurance that any such license, rights of way or surface rights will be granted, or if granted will be on terms acceptable to Falco and in a timely manner.*

*Falco notes that the timeline of activities described in this chapter, and the estimated timing proposed for commencement and completion of such activities, is subject at all times to matters that are not within the exclusive control of Falco. These factors include the ability to obtain, and to obtain on terms acceptable to Falco, financing, governmental and other third party approvals, licenses, rights of way and surface rights (as described above in Chapters 16, 18 and 20).*

*Although Falco believes that it has taken reasonable measures to ensure proper title to its assets, there is no guarantee that title to any of assets will not be challenged or impugned.*

*The foregoing disclaimer hereby qualifies in its entirety the disclosure contained in Chapter 24.*

## 24.1 Project Organization

### 24.1.1 Engineering and Procurement

All Project phases including detailed engineering, procurement, preproduction and construction activities will be under the direction of the Falco Vice-President, Engineering and Construction.

Permitting and Project financing will be supported by Falco Environmental and Financial teams respectively.

Falco has an internal experienced mine project development team and will be in charge of the Project management functions for the Horne 5 Project. The team consists of highly experienced individuals with knowledge of the local construction conditions and contractors. They have successfully managed projects in difficult conditions and remote environments for the engineering and planning stages through construction to commissioning and operations.

The Falco technical group will supervise the Project detailed engineering. During the FS phase, mine surface infrastructure (hoisting equipment) and water treatment plant detailed engineering has already been initiated by engineering firms as well as the procurement process for underground mobile equipment, shaft rehabilitation, mechanical equipment and electrical equipment.

Engineering firms will be responsible for the following procurement functions:

- Technical specification and scope of work documents;
- Technical and economical evaluations;
- Short list meetings;
- Purchase order requisition preparation;
- Drawing management and approval;
- Reception and coordination of vendor maintenance and operational documents.

The Falco technical team is responsible for the following procurement functions:

- Bid request;
- Addenda;
- Reception of bids;
- Final negotiation;
- Contract award;
- Purchase order release;
- Progressive payment;
- Shop visits;
- Site logistics.

During the FS, Falco retained the professional services of architects and engineers for institutional building relocation and initiated detail engineering.

Due to the complexity of major process equipment transportation, Falco will retain the services of a specialized company in international logistics services.

### 24.1.2 Construction Management

Falco will provide Project construction management services under the direction of the Construction Manager. The Construction Management Team (“CMT”) will include the following services:

- Site supervision;
- Project cost control;
- Scheduling;
- Reporting;
- Health and safety;
- Site procurement and logistics.

It is recognized that an effective health and safety program during the Project is a necessity. The success of the construction safety program is contingent upon its enforcement at all stages of the Project, including design, construction planning, construction execution, and start-up and commissioning.

The CMT will receive technical support from vendor’s representatives who will assist in most of the major process and mechanical equipment installations.

The CMT will also follow the Horne 5 procedures and work methods to ensure the protection of the environment. Furthermore, the CMT will work closely with each department of the operations group to ensure proper installation and functional results. During the construction phase, personnel from operations will be integrated into the construction team as coordinators and supervisors.

The Horne 5 operations group will support the CMT for the following services during the construction phase:

- Staff payroll;
- Accounting support;
- IT support;
- Site security;
- Public relations;
- Environmental and permitting;
- Medical and first aid;
- Site logistics.

Figure 24-1 shows the general Project Construction Management Team organizational chart.



Construction Management  
 Organizational Chart

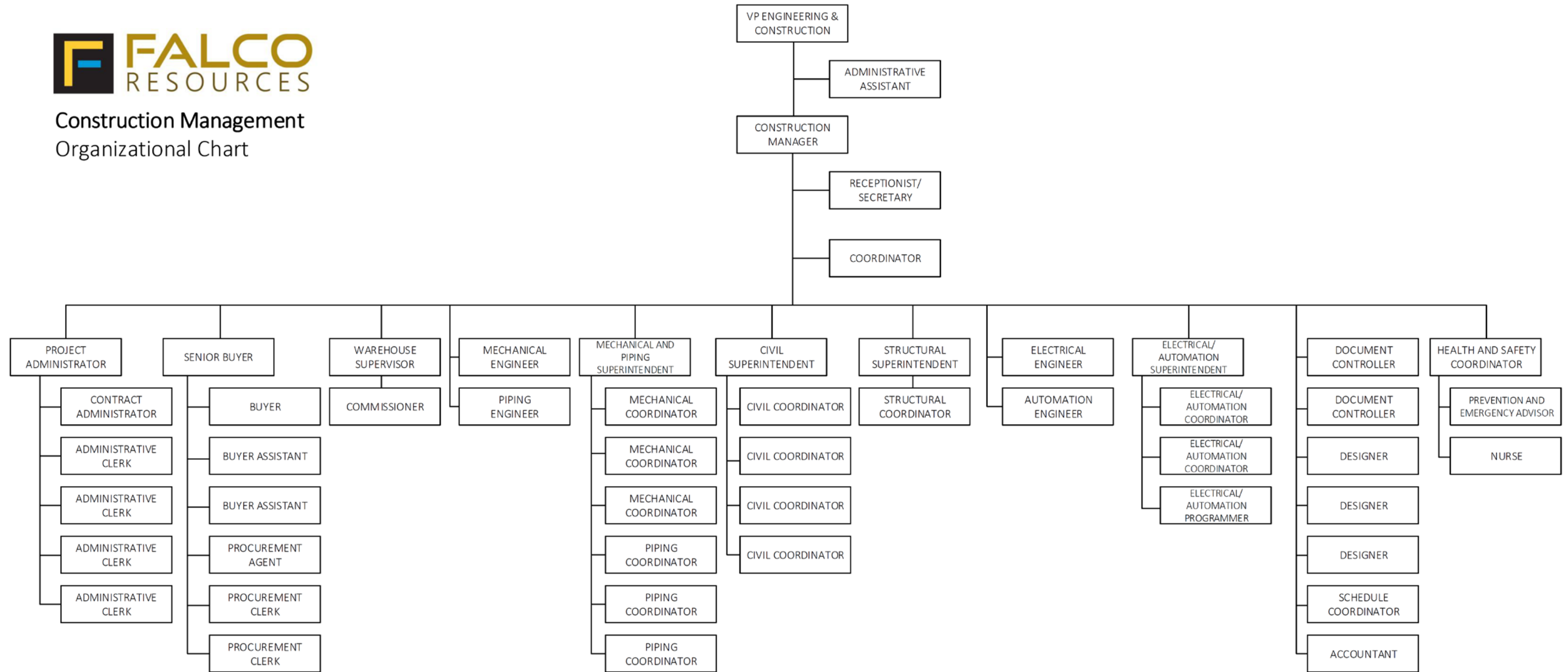

Figure 24-1: Project construction management team organizational chart

## 24.2 Project Execution Plan

This execution plan is conceptual in nature and will be adjusted and refined during the next phases of the Project.

The durations and milestones for the major Project activities are shown in Table 24-1.

Table 24-1: Key Project activities

Activity	Start Date	Completion Date
Feasibility Study		Completed
Environmental Impact Assessment (EIA)	Q2 2016	Q4 2017
Detailed Engineering	Q4 2017	Q2 2020
Mine Dewatering	Q2 2018	Q2 2020
Head Frame & Hoist Room Construction (Mine Dewatering and Rehabilitation Phase)	Q4 2017	Q3 2018
Quemont No. 2 Shaft Rehabilitation	Q2 2018	Q4 2019
Public Audiences – “BAPE”	Q4 2018	Q1 2019
Permit for Project Construction		Q2 2019
Process Plant Construction	Mid-2019	Q1 2021
Preproduction Mine Development	Q3 2019	Q2 2021
First Mineralized Material from Mine		Q2 2021
Production achieved in Mine (Phase 1)		Q3 2021
Process Plant Commissioning	Q2 2021	Q2 2021
Process Plant Ramp-Up		H2 2021
Full Mine Production (Phase 1)		H1 2022
Surface TMF Operations	Q2 2023	
Quemont No. 2 Shaft Deepening	Q1 2027	Q2 2028
Production Achieved in Mine (Phase 2)	Q3 2028	

Upon completion of this FS, Falco plans to proceed with the detailed engineering phase of the Project with a targeted completion by Q2 2020. Detail engineering will be initiated for each area as is required by the Project schedule. In parallel, environmental studies will be completed and the consultation process for the permits required for construction and operation of the Project facilities will be initiated. The preliminary Project execution schedule, developed in this FS study and described herein, covers the period from the end of the FS up to the achievement of full mine production in H1 2022. Several key dates during the LOM were also included.



The EIA is expected to be completed in Q4 2017. The public hearings process following presentation of the Project is expected to be completed by the end of Q1 2019.

The schedule includes consideration of early work requirements, various studies, the environmental process, basic engineering, the procurement of long lead items and critical equipment, detail engineering, construction, and commissioning of the facilities, including the power line and main substation, processing installations, tailings and water management infrastructure and site infrastructure required for the Project. The dewatering of historic mine workings and the rehabilitation of the Quemont No. 2 shaft, construction of a new headframe, hoist room, and a preproduction water treatment plant are included during the dewatering and rehabilitation period of the Project, while underground mine development and underground infrastructure construction required to achieve full underground capacity are also covered in the Project implementation schedule.

On-site construction at the Horne 5 Mining Complex is planned to start in Q4 2017 with the dewatering and rehabilitation phase, which includes the hoist room, the headframe (partial) and the preproduction water treatment plant, lasting twelve months. This will be followed by the dewatering of the historic Horne, Quemont and Donalda mines and the rehabilitation of the Quemont No. 2 shaft and associated development work. This work will proceed following reception of a permit for the construction of the infrastructure required for underground dewatering and rehabilitation.

Renovation of existing site buildings that will be used as the mine building and dry, the administration building, the warehouse, and the service building will be completed as required, as will the construction of the community infrastructure component of the Project.

The construction of other surface facilities, including the main electrical substation, the installations of the production hoist in the headframes, the process plant, the ore storage stockpile and reclaim, and the underground mine development activities will begin in mid-2019 following receipt of the certificate of authorization. Site preparation and bulk excavation will start in mid-2019 and the remainder of the construction will follow until completion in Q2 2021. This is in line with recent projects of similar scope and size.

An analysis of the construction schedule developed for the Project allowed for the development of a preliminary workforce distribution as shown in Figure 24-2. The preliminary on-site workforce requirement is expected to peak at approximately 950 individuals during the construction phase. The total estimated workforce accounts for rehabilitation of the Quemont No. 2 shaft and the development of the underground mine, direct and indirect construction labour, along with commissioning crews. An allowance for Falco CMT and Horne 5 operations staff has also been included.

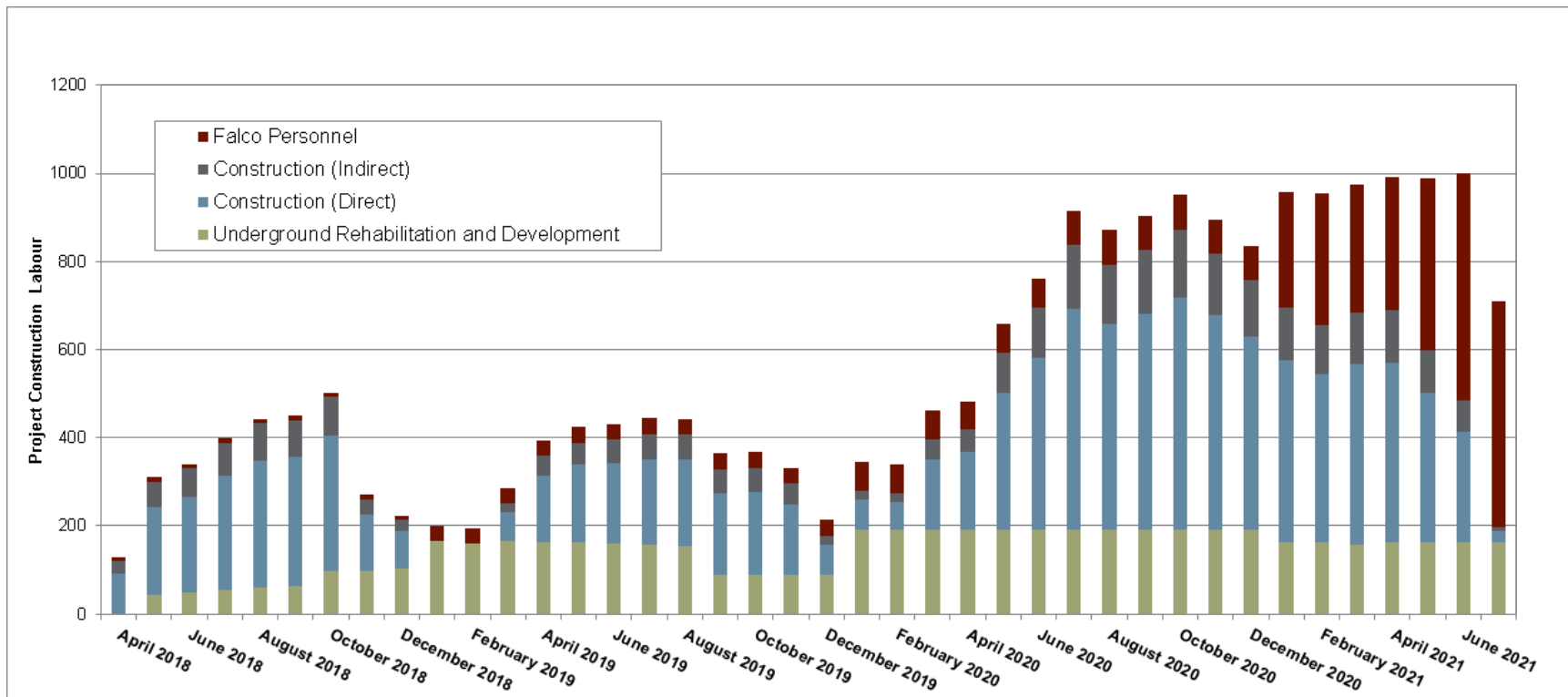

Figure 24-2: Construction phase on-site workforce requirement  
 (Full-time equivalent based on 40-hour work week)

The Project critical path runs through the mine dewatering, the approval of the underground dewatering and rehabilitation permit, the erection of the headframe and installation of the service and auxiliary hoists, the mine shaft rehabilitation and horizontal development required to reach the first areas of the deposit to be mined. The surface infrastructure and process plant are planned to achieve readiness for commissioning with the first availability of mineralized material from the mine. An approximate 10-month ramp up period is expected to achieve full production capacity.

The process plant construction is scheduled to begin in mid-2019. The excavation and building foundations for the process plant will be the first priority. The structural steel erection and building envelopes will follow, aiming for an enclosed process plant by the end of Q3 2020. While the building siding and roofing is proceeding, internal equipment foundations and slabs will be built, followed by mechanical, piping, electrical and automation installation work completing by the end of Q1 2021. Pre-operational verification and commissioning will be completed to allow first mineralized material production in Q2 2021.

Although the longest equipment deliveries are approximately 12 months after issuing of an order, none are on the Project critical path on the current plan as the production, service and auxiliary hoists have been purchased and firm price request for proposals have been completed for all underground mine mobile equipment, as well as mine surface and process plant major mechanical and electrical equipment. Equipment purchase will proceed by priority as required by the Project schedule.

The dates of the engineering and procurement schedule in this plan will allow for a design of sufficient level of completion to be available for the bid process of the construction contracts. With such a level of engineering, Falco will be in a position to request reliable target price contracts and have improved control on Project costs and schedule.

Once in production, there will be several significant periods of construction during the mine life. TMF construction will begin in Q2 2022 in order to be operational for Q2 2023. Tailings and reclaim pipelines, polishing pond, TMF site water management infrastructure and reclaim pump house construction will begin in Q2 2022 for completion at the same time as the TMF.

The Quemont No. 2 shaft re-sinking will begin at the beginning of 2027 and end in Q2 2028. Once the shaft re-sinking is complete, rope changeovers will be carried out on the production, service and auxiliary hoists. First production from Phase 2 of the mine will occur in the second half of 2028.

## 25. INTERPRETATION AND CONCLUSIONS

*Pursuant to an agreement between Falco and a Third Party, Falco owns rights to the minerals located below 200 metres from the surface of mining concession CM-156PTB, where the Horne 5 deposit is located. Under the agreement, ownership of the mining concession remains with the Third Party.*

*In order to access the Horne 5 Project, Falco must obtain one or more licenses from the Third Party, which may not be unreasonably withheld, but which may be subject to conditions that the Third Party may require in its sole discretion. These conditions may include the provision of a performance bond or other assurance to the Third Party and the indemnification of the Third Party by Falco. The agreement with the Third Party stipulates, among other things, that the license shall be subject to reasonable conditions which may include, among other things, that activities at Horne 5 will be subordinated to the current use of the surface lands and subject to priority, as established in such party's sole discretion, over such activities. Any license may provide for, among other things, access to and the right to use the infrastructure owned by the Third Party, including the Quemont No. 2 shaft (located on mining concession CM-243 held by such Third Party) and some specific underground infrastructure in the former Quemont and Horne mines.*

*While Falco believes that it should be able to timely obtain the licenses from the Third Party, there can be no assurance that any such license will be granted, or if granted will be on terms acceptable to Falco and in a timely manner.*

*Although Falco believes that it has taken reasonable measures to ensure proper title to its assets, there is no guarantee that title to any of assets will not be challenged or impugned.*

*Falco also notes that the timeline of activities described in the current chapter, and the estimated timing proposed for commencement and completion of such activities, is subject at all times to matters that are not within the exclusive control of Falco. These factors include the ability to obtain, and to obtain on terms acceptable to Falco, financing, governmental and other third party approvals, licenses, rights of way and surface rights (as described above in Chapters 16, 18 and 20).*

*The foregoing disclaimer hereby qualifies in its entirety the disclosure contained in this Chapter 25 of this Report.*

## 25.1 Overview

BBA, InnovExplo, Golder, WSP, SNC-Lavalin and RIVVAL, were mandated by Falco to prepare a feasibility study conforming to NI 43-101 standards to demonstrate the economic viability of the Horne 5 Project. The Project is based on the November 2016 mineral resources estimate as defined by InnovExplo effective September 26, 2016.

This NI 43-101 compliant technical report on Falco's Horne 5 Project was prepared by experienced and competent independent consultants using accepted engineering methodologies and standards. It provides a summary of the results and findings from each major area of investigation including exploration, geological modelling, mineral resource, plant feed estimations, mine design, metallurgy, process design, infrastructure, environmental management, tailings and water management, capital and operating costs and economic analysis. The level of investigation for each of these areas is considered to be consistent or surpassing with that normally expected with a feasibility study.

The mutual conclusion of the QPs is that the Horne 5 Project as summarized in this FS contains adequate detail and information to support the positive economic outcome shown. The results of this feasibility study indicate that the Horne 5 Project is technically feasible and has financial merit at the base case assumptions considered. The Horne 5 Project contains substantial precious metal and base metal resources that can be mined by underground methods and recovered using conventional processing technologies.

To date the QPs are not aware of any fatal flaws in the Horne 5 Project and the results are considered sufficiently reliable to guide Falco management in a decision to further advance the Project. It is recommended that the Horne 5 Project proceed to the detailed engineering phase and that project execution activities commence at Falco's discretion. The QPs recommend that Falco obtain the required licenses from third parties in an expedient fashion, if not the project execution timeline and costs as outlined in this FS may be negatively impacted. While the QPs do not believe that such license will not be forthcoming, there can be no assurance that any such license will be granted on terms acceptable to Falco.

## 25.2 Land Tenure, License Agreements and Royalties

The portfolio of properties, with respect to which Falco holds certain rights, consists of 2,114 mining claims and 17 mining concessions in non-contiguous blocks covering an aggregate surface area of 68,945.54 hectares (689.5 km<sup>2</sup>). All the mining claims are registered under the name of Falco and/or certain joint venture partners (except for 31 claims registered under the name of Glencore Canada Corporation ("Glencore Canada", the "Third Party")). The 17 mining concessions are registered under the name of Glencore Canada. Certain mining titles are subject to a number of agreements.

The Property is divided into five parts, as described in the purchase agreement of September 12, 2012, between Xstrata Canada Corporation (now Glencore Canada) and Falco, as follows:

1. “Horne Mines Ltd Controlled Properties”
2. “Lac Montsabrais Property”
3. “Noranda Properties”
4. “Third Party Interest Properties”
5. “West Ansil Discovery Property”

Mining concession CM-156PTB (the “Concession”), on which lies the Horne 5 deposit, is part of the Controlled Properties. The Concession has an irregular shape and a surface area of 191.96 hectares.

Mining concession CM-243 (“Concession 243”), on which lies the Quemont No. 2 shaft, is part of the Controlled Properties. The Concession 243 has a surface area of 224.90 hectares.

In the opinion of the QPs, the following interpretations and conclusions are valid:

- Pursuant to an agreement between Falco and the Third Party, Falco owns rights to the minerals located below 200 metres from the surface of the Concession, where the Horne 5 deposit is located. Falco also owns certain surface rights surrounding the Quemont No. 2 shaft located on the Concession 243. Under the agreement, ownership of the Concession and Concession 243 remains with the Third Party;
- Glencore Canada owns the mining rights to the Concession and to Concession 243 including 100% of the rights to the minerals contained between the surface and a depth of 200 m below the surface;
- The Concession is subject to a 2% NSR Royalty in favour of Glencore Canada;
- Permitting and license agreements with mining rights owner Glencore Canada is necessary if Falco is to perform exploration work or mining activities on the Concession and Concession 243;
- The Concession and Concession 243 is located within an urbanized perimeter;
- Except pursuant to licenses granted by Glencore Canada, as applicable, Falco is not responsible for any environmental liability relating to the surface rights, the mineral rights and the minerals contained at a depth of less than 200 m below the surface of the Concession and Concession 243. However, upon commencement of the development and operations at Horne 5, Falco will have statutory environmental liabilities for such operations.

### 25.3 Data Verification

The NI 43-101 compliant mineral resource estimate presented in this Report (the “October 2017 MRE”) covers the area of the past-producing Horne mine on the Concession, specifically the part below a depth of 200 m.

The objective of InnovExplo’s assignment was to prepare an updated NI 43-101 compliant mineral resource estimate for the Horne 5 deposit. The result — the October 2017 MRE — is mainly based on changes made to the NSR parameters, supported by new assumptions concerning metal prices and net recoveries. Three additional DDH and 41 updated downhole surveys from the 2015–2016 confirmation drilling program were also used in this October 2017 MRE. No changes to the interpretation were deemed necessary. The resource model for the October 2017 MRE is based largely on the model generated for the November 2016 MRE (Pelletier et al., 2016).

The October 2017 MRE is largely supported by historical data. For this reason, a great deal of effort was made during the data verification process to obtain the highest degree of confidence as possible in terms of dataset quality and precision. The historical information used in this Report was taken from reports produced before the implementation of NI 43-101. No information about sample preparation, analytical or security procedures is available in the reviewed historical documents. InnovExplo assumes that the exploration activities conducted by earlier companies were in accordance with prevailing industry standards at the time.

InnovExplo’s data verification from 2013 to 2016 increased the confidence of the datasets supporting the October 2017 MRE, particularly in terms of geometry, geological continuity and grade continuity for the mineralized zones defined in the Horne 5 deposit. The historical drilling database is the principal supporting information for the October 2017 MRE. In addition, the 2015-2016 confirmation and exploration drilling program allowed Indicated resources to be classified in the March 2016 MRE, and the historical underground channel sample compilation allowed a portion of the Indicated resources to be converted into Measured resources in the November 2016 MRE (Table 25-1).

InnovExplo believes that the local differences in grades between the historical and 2015-2016 drilling programs will be mitigated at the scale of the mine plan presented in the FS.

InnovExplo considers the data to be valid and of sufficient quality to be used for the October 2017 MRE.



Table 25-1: Evolution of Horne 5 datasets and mineral resource estimates

Data set	Year			
	April 2014 MRE (February 17, 2014) <sup>(3)</sup>	March 2016 MRE (January 8, 2016) <sup>(3)</sup>	November 2016 MRE (September 26, 2016) <sup>(3)</sup>	2017 October MRE (July 25, 2017) <sup>(3)</sup>
Overall UG historical DDH	4,384	10,984	10,984	10,984
UG historical DDH used	4,384	4,384	5,938	5,938
Historical metallurgical test DDH data <sup>(1)</sup>	Not compiled	2,112	2,112	2,112
Historical UG sampling (channel samples)	Not compiled	Not compiled	14,799	14,799
2015-2016 confirmation surface drill holes	n/a	27	31	31
2015-2016 proximal exploration surface DDH	n/a	Not completed	8	11
Volume of historical developments and mined-out voids	6,197,597 m <sup>3</sup>	6,197,597 m <sup>3</sup>	6,341,746 m <sup>3</sup>	6,341,746 m <sup>3</sup>
<b>Interpreted Mineralized Zones</b>				
Volume of the main envelope (ENV_A)	38,511,116 m <sup>3</sup>	47,715,405 m <sup>3</sup>	50,102,486 m <sup>3</sup>	50,102,486 m <sup>3</sup>
Number of other envelopes (ENV_B to ENV_F)	3	3	5	5
Number of high-grade zones for Gold <sup>(2)</sup>	5	5	6	6
Number of high-grade zones for Silver <sup>(2)</sup>	-	2	3	3
Number of high-grade zones for Copper <sup>(2)</sup>	-	1	1	1
Number of high-grade zones for Zinc <sup>(2)</sup>	-	1	1	1
Number of high-grade zones for Density <sup>(2)</sup>	-	1	1	1
<b>Data Validation Process</b>				
Historical DDH verification	10% of 4,384 UG DDH (n=439)	5% of 6,600 additional Surface and UG DDH (n=330)	No UG DDH added	No UG DDH added
Historical assay verification	Assays for the validated 10%: n= 14,899	Assays for the validated 5%: n= 17,820	No UG DDH added	No UG DDH added
Historical DDH with remaining core	16 UG DDH resampled	No UG DDH with remaining material	No UG DDH with remaining material	No UG DDH with remaining material
Confirmation and exploration drill hole verification	n/a	QA/QC for 2015 confirmation drilling program	QA/QC for 2015-2016 confirmation and exploration drilling program	No additional validation
Verification of historical UG sampling (channel samples)	Not compiled	Not compiled	Global validation for every sampled drift	No additional validation
Impact on Mineral Resource Classification	MRE is entirely supported by historical DDH data. The 16 resampled historical DDH indicated a good reproducibility for gold, copper, zinc and silver, but they represent a small portion of the entire database. Only Inferred mineral resources are defined.	Confirmation drilling program confirmed the accuracy of grades from historical drilling, and also confirmed the geometry, geological continuity and grade continuity of the deposit. The 19 DDH intercepting the Horne 5 deposit added 1,237 m of mineralized intervals to the database and confirmed the identified low- and high-grade gold zones. This program supported the classification of a large portion of resources as Indicated mineral resources (81%).	Compilation of historical channel samples added 14,799 samples to the database. Sampling was done continuously in 23 of the 24 historical drifts in the Horne 5 deposit. Locally and globally, the samples confirmed the grades and locations of low- and high- grade gold zones. Channel samples were used to support the classification of 15-m blocks around sampled drifts as Measured mineral resources (10%). The four DDH from the 2015-2016 confirmation and exploration program with mineralized intervals intersecting the Horne 5 deposit added 336 m to the database and confirmed again the geometry and geological/grade continuity both locally and globally.	The use of variable recoveries for each commodities enhanced local accuracy of grade estimation. The three DDH from the 2015-2016 confirmation and exploration program with mineralized intervals intersecting the Horne 5 deposit confirmed again the geometry and geological/grade continuity both locally and globally. The update of the commodities prices and exchange rates better reflect current market values.
<b>Resource categories</b>	<b>Inferred</b>	<b>Indicated and Inferred</b>	<b>Measured, Indicated and Inferred</b>	<b>Measured, Indicated and Inferred</b>

MRE = mineral resource estimate; UG = underground; DDH = diamond drill hole

<sup>(1)</sup> Note that 2,112 drill holes belong to the overall UG historical DDH database.

<sup>(2)</sup> Note that high-grade zones may overlap each other.

<sup>(3)</sup> Date in brackets is the effective date of the resource estimates.

## 25.4 Mineral Resource Estimate

The October 2017 MRE, effective as of July 25, 2017 and presented herein, was prepared by Carl Pelletier, P.Geo., using all available information. The main objective was to update the previous NI 43-101 mineral resource estimate for the Horne 5 deposit, which was prepared by InnovExplo and published in a report titled “Technical Report and Updated Mineral Resource Estimate for the Horne No. 5 Deposit”, dated November 7, 2016 (Pelletier et al., 2016) (the “November 2016 MRE”).

The October 2017 MRE is mainly based on changes made to the NSR parameters, supported by new assumptions concerning metal prices and net recoveries. Three additional DDH and 41 updated downhole surveys from the 2015–2016 confirmation drilling program were also used in this October 2017 MRE. No changes to the interpretation were deemed necessary. The resource model for the October 2017 MRE is based largely on the model generated for the November 2016 MRE (Pelletier et al., 2016).

The mineral resources presented herein are not mineral reserves as they have no demonstrable economic viability. The interpretation of mineralized zones was updated using a total of 5,980 additional DDH and 14,799 channel samples. The resource model is based largely on the model generated on past mineral resource estimates and complemented by two additional mineralized envelopes and one additional high-grade subzone. The result of this Report is a single mineral resource estimate for six mineralized envelopes: ENV\_A, ENV\_B, ENV\_C, ENV\_D, ENV\_E and ENV\_F. The distribution of metal contents in the main mineralized envelope (ENV\_A) defines 11 high-grade subzones: six for gold (HG\_A to HG\_F), one for copper (Cu\_HG), one for zinc (Zn\_HG) and three for silver (HG\_D, HG\_F and SG\_HD). The October 2017 MRE includes Measured, Indicated and Inferred resources for an underground volume.

The October 2017 MRE was made using 3D block modelling and the inverse distance square interpolation (“ID<sup>2</sup>”) method in a wireframe model of the Horne 5 deposit. The model has a strike length of 800 m, a width ranging from 7 m to 120 m, and a vertical depth from 600 m to 2,600 m below surface.

Given the nature of the data, the density of the processed data, the search ellipse criteria and the specific interpolation parameters, InnovExplo is of the opinion that the October 2017 MRE can be classified as Measured, Indicated and Inferred resources. Resources in the Measured category are reported for the first time on the Horne 5 Project. The NSR cut-off is supported by economic assumptions defined in the PEA prepared by BBA, dated June 23, 2016 (Hardie et al., 2016) (the “2016 PEA”). The October 2017 MRE also used an updated NSR calculation supported by new assumptions concerning metal prices, net recoveries and smelting costs.

---

The October 2017 MRE is compliant with CIM standards and guidelines for reporting mineral resources and reserves. The selected NSR cut-off of 55 \$/t allowed the mineral potential of the deposit to be outlined for an underground mining option. While the results are presented undiluted and in situ, the reported mineral resources are considered by the QP to have reasonable prospects for economic extraction.

The results of the October 2017 MRE at the base case cut-off of \$55 NSR are presented in Table 25-2.

Table 25-2: Horne 5 mineral resource (July 25, 2017)

Resource Category	Tonnes (Mt)	AuEq (g/t)	Au (g/t)	Ag (g/t)	Cu (%)	Zn (%)	Contained AuEq (Moz)	Contained Au (Moz)	Contained Ag (Moz)	Contained Cu (Mlbs)	Contained Zn (Mlbs)
Measured	9.3	2.59	1.58	16.2	0.19	0.83	0.770	0.470	4.824	38.0	168.5
Indicated	81.9	2.56	1.55	14.74	0.18	0.89	6.731	4.070	38.796	325.4	1,599.3
Inferred	21.5	2.51	1.44	23.04	0.20	0.71	1.736	1.000	15.925	96.3	337.2

Notes:

- The effective date of the resource estimate is July 25, 2017. The Independent and QP for the Mineral resource estimate as required by National Instrument 43-101 is Carl Pelletier, P. Geo., B.Sc., employee of InnovExplo Inc.
- Mineral resources are not Mineral reserves and do not have demonstrated economic viability.
- While the results are presented undiluted and in situ, the reported mineral resources are considered by the QP to have reasonable prospects for economic extraction.
- These estimates include six low-grade gold-bearing mineralized envelopes.
- The main low-grade, gold-bearing mineralized envelope includes six high-grade gold-bearing zones, one high-grade copper-bearing zone, one high grade zinc-bearing zone and three high-grade silver-bearing zones. Note that these high-grade zones may overlap each other.
- Resources were compiled at NSR cut-offs of: \$40, \$45, \$50, \$55, \$60, \$65, \$70, \$75, \$80, \$85, \$90, \$95 and \$100 per tonne for sensitivity purposes.
- The official base case resource is reported at a 55 \$/t NSR cut-off.
- The appropriate NSR cut-off will vary depending on prevailing economic and operational parameters to be determined.
- NSR estimates are based on the following assumptions: Exchange rate of 1.28 CAD/1.00 USD; Metal prices as follows: gold 1,300 USD/oz, silver 19.50 USD, copper 2.90 USD/lb and zinc 1.10 USD/lb, inspired from a long-term analyst consensus price forecast study; net recoveries are variable in function of grade of each commodity. Smelting cost (including transportation) of 6.52 USD/t (based on the Cost Mine Service, as well as a non-public smelter contract obtained from one of the proposed destinations and talks with transport providers).
- Gold equivalent calculations assume these same metal prices.
- Inferred mineral resources are separate from Indicated mineral resources.
- The quantity and grade of reported Inferred mineral resources are uncertain in nature and there has not been sufficient work to define these Inferred mineral resources as Indicated or Measured mineral resources. It is uncertain if further work will result in upgrading them to an Indicated or Measured mineral resource category.
- The mineral resource was estimated using Geovia GEMS 6.8. The estimate is based on 5,980 DDH (483,254 m), of which 4,141 cut mineralized zones for a total of 178,150 m of core within these zones. For silver, the estimate also uses the results of an exhaustive metallurgical test comprising 2,112 DDH assayed for silver over a total length of 75,540 metres. A minimum true thickness of 7.0 m was applied, using the grade of the adjacent material when assayed, or a value of zero when not assayed. Only the silver interpolation in the Inferred resources does not use the material when not assayed.
- The estimate database also contains 14,799 channel samples for a total of 23,791 m from historically sampled drifts. Channel sample data was only used for distance to composite criterion for resource classification purposes.
- 91% of density values were estimated using historical iron assay drill hole data and Falco density data for an average of 3.41 g/cm<sup>3</sup>. The interpolation method uses three passes for the ENV\_A and HG\_A to HG\_F zones. 8% of the density values were fixed at 2.88 g/cm<sup>3</sup> for ENV\_B to ENV\_E due to the scarcity of the data. 2.88 g/cm<sup>3</sup> represents the median of the available data. 1% of density values were fixed at 2.67 g/cm<sup>3</sup> for ENV\_F due to the scarcity of the data and to adequately characterize this quartz-rich zone.
- Compositing was done on drill hole sections falling within the mineralized zones (composite = 3.0 m). Tails shorter than 0.75 m were not generated.
- Resources were evaluated from drill holes using an ID<sup>2</sup> interpolation method in a block model (block size = 5 x 5 x 5 m).
- High-grade capping was done on raw assay data and established on a per zone basis for gold (Au g/t): (HG\_A: 35; HG\_B: 35; HG\_C: 25; HG\_D: 35; HG\_E: 25; HG\_F: 35; ENV\_A: 35; ENV\_B: 25; ENV\_C: 25; ENV\_D: 20; ENV\_E: 35; ENV\_F: 25) and for silver (Ag g/t): SG\_HG:100; HG\_D: 165; HG\_F: 165; ENV\_A\_SG\_Low: 110; ENV\_B: 100; ENV\_C: 100; ENV\_D: 100. Capping grade selection is supported by statistical analysis. No capping was applied to the Cu and Zn data based on statistical analysis.
- The reported mineral resources are categorized as Measured, Indicated and Inferred. The Inferred category is only defined within the areas where blocks were interpolated during pass 1 or pass 2 in areas where continuity is sufficient to avoid isolated blocks. The Indicated category is only defined by blocks interpolated in areas where the maximum distance to the closest drill hole composite is less than 25 m for blocks interpolated in passes 1 and 2. The Measured category is only defined by blocks classified as Indicated and within sufficient proximity to sampled drifts (< 15m). The average distance to the nearest composite is 6.97 m for the Measured mineral resources, 10.01 m for the Indicated resources and 40.10 m for the Inferred mineral resources.
- Tonnage estimates were rounded to the nearest hundred tonnes. Any discrepancies in the totals are due to rounding effects. Rounding practice follows the recommendations set forth in Form 43-101F1.
- CIM definitions and guidelines were followed in estimating mineral resources.
- InnovExplo is not aware of any known environmental, permitting, legal, title-related, taxation, socio-political, marketing or other relevant issue that could materially affect the mineral resource estimate, other than the third party approvals previously mentioned.
- Metal contained in ounces (troy) = metric tons x grade / 31.10348. Calculations used metric units (metres, tonnes and g/t). Metal contents are presented in ounces and pounds.

## 25.5 Mineral Reserve Estimate

The mineral reserves estimate (Table 25-3) for the Horne 5 Project was prepared by Mr. Patrick Frenette P.Eng., an employee of InnovExplo Inc., and is effective as of August 26, 2017. The mineral reserves estimate stated herein is consistent with the CIM Standards on Mineral Resources and Mineral Reserves and is suitable for public reporting. As such, the mineral reserves are based on Measured and Indicated resources, and do not include any Inferred resources. Measured and Indicated resources are inclusive of Proven and Probable reserves.

The FS LOM plans and mineral reserves estimate were developed from the previous November 2016 MRE and does not consider the October 2017 MRE. Updated metal prices, exchange rates and recovery equations from the October 2017 MRE were used to calculate cash flows used to support the reserve estimate. As of the date of this Report, the QP has not identified any risks, legal, political or environmental, that would materially affect potential development of the mineral reserves (see Section 15.1) other than the third party license agreements as described in Chapter 4.

Table 25-3: Statement of mineral reserves (August 26, 2017)

Category	Tonnes (Mt)	NSR (\$)	Au (g/t)	Ag (g/t)	Cu (%)	Zn (%)
Proven	8.4	91.72	1.41	15.75	0.17	0.75
Probable	72.5	92.56	1.44	13.98	0.17	0.78
Proven + Probable	80.9	92.41	1.44	14.14	0.17	0.77

Notes:

1. The Qualified Person for the mineral reserve estimate is Mr. Patrick Frenette.
2. Mineral reserves have an effective date of August 26, 2017.
3. Estimated at 2.15 USD/lb Cu, 1.00 USD/lb Zn, 1,300 USD/oz Au and 18.50 USD/oz Ag, using an exchange rate of 1.30 CAD:USD, cut-off NSR value of 55.00 \$/t.
4. Mineral reserve tonnage and mined metal have been rounded to reflect the accuracy of the estimate and numbers may not add due to rounding.
5. Mineral reserves presented include both internal and external dilution along with mining recovery. The external dilution is estimated to be 2.3%. The mining recovery factor was set at 95% to account for mineralized material left in the margins of the deposit in each block.

## 25.6 Mining Methods

***Pursuant to an agreement between Falco and a third party, Falco owns rights to the minerals located below 200 metres from the surface of mining concession CM-156PTB, where the Horne 5 deposit is located. Under the agreement, ownership of the mining concession remains with the third party.***

***In order to access the Horne 5 Project, Falco must obtain a license from the third party, which may not be unreasonably withheld, but which may be subject to conditions that the third party may require in its sole discretion. These conditions may include the provision of a performance bond or other assurance to the third party and the indemnification of the third party by Falco. The agreement with the third party stipulates, among other things, that the license shall be subject to reasonable conditions which may include, among other things, that activities at Horne 5 will be subordinated to the current use of the surface lands and subject to priority, as established in such party's sole discretion, over such activities. Any license may provide for, among other things, access to and the right to use the infrastructure owned by the third party, including the Quemont No. 2 shaft (located on mining concession CM-243 held by such third party) and some specific underground infrastructure in the former Quemont and Horne mines.***

***While Falco believes that it should be able to timely obtain the licenses from the third party, there can be no assurance that any such license will be granted, or if granted will be on terms acceptable to Falco and in a timely manner.***

***Although Falco believes that it has taken reasonable measures to ensure proper title to its assets, there is no guarantee that title to any of assets will not be challenged or impugned.***

***The foregoing disclaimer hereby qualifies in its entirety the disclosure contained in this Chapter 25.***

### 25.6.1 Overview

The proposed underground mine design supports the extraction of approximately 15,500 tpd average over the LOM of ore by transverse long-hole stoping, with primary and secondary stopes, with some areas being mined with the longitudinal mining retreat method. These mining methods are suitable, given the geometry, ground conditions and depth of the resources. Paste backfill is a key component for maximizing ore recovery and mining productivity. An ore recovery rate of 95% was applied to each mining stope. Individual dilution was calculated for each stope, giving an average dilution of 2.3%. An 80% recovery factor was also added for the sills of Phase 2, to take into account any ground problems that could occur.

The mine has been designed to have low operating costs through the extensive use of automation, implementation of large modern remote controlled trackless equipment, gravity transport of mineralized material and waste through raises, shaft hoisting, minimal mineralized material and waste re-handling, and high productivity bulk mining methods.

For the Horne 5 deposit to be mined, the old excavations surrounding the mining area, including the interconnected historical Horne, Quemont and Donalda mines, must be dewatered. According to the preproduction schedule, the dewatering of the Horne 5 Project is expected to take approximately two years from the day pumping is initiated.

## 25.6.2 Geotechnical and Hydrogeological Considerations

The geotechnical assessment for the underground mine is based upon existing openings, the resource envelope, level plans and the geological model. During the FS several site geotechnical conditions were confirmed and the design was updated to reflect modifications in the Project. The following key activities were undertaken for the FS:

- Updated the PEA underground rock mass characterization with additional data collected after the release of the PEA;
- Conducted laboratory testing program to better define rock strength and behaviour;
- Performed numerical stress modelling to support mine design;
- Confirmed larger stope dimensions for Phase 1 and Phase 2;
- Established mining sequence and approach to manage stresses and seismicity for converging mining front, sill pillars, diabase dikes, and narrower orebody sections;
- Confirmed stand-off distance and sequence around historical Horne mine and maintained recommendation for higher binder content backfill in stopes near historic mine workings;
- Confirmed location of infrastructure such as crushers, garage, ore passes, and ventilation raises, as well as footwall drifts. In particular, confirmed location of footwall drifts in ore between L1026 and L1235 as an opportunity to reduce development costs;
- Recommended ground support for assumed conditions of gravity-driven wedges, stress fractured ground, and rock bursting (dynamic support);
- Confirmed the PEA level paste backfill strength requirements based on testing data conducted for the FS;
- Provided guidance on mine monitoring needs;
- Reviewed and assessed from a rock mechanics perspective the interpretation of secondary and primary major faults provided by InnovExplo.

From the FS activities listed above, the following items describe the key outcomes:

- The mining sequence was assessed, challenges identified, and solutions or mitigation measures provided;
- Recommendations for mining in proximity to the historical Horne mine were provided;
- Stope dimensions were confirmed;
- Sill pillar dimensions were refined and extraction options provided;
- Destressing of identified areas has been provided;
- Footwall drifts within the ore between levels L1026 to L1235 have been considered feasible.



Fieldwork studies were performed in the summer of 2015 and autumn of 2016 to determine the hydrogeological conditions on the Horne 5 Mining Complex site. The tests performed consisted of a packer test profile and the implementation of nine observation wells at four different locations. Based on the hydrogeological design basis developed, groundwater inflows were estimated and thus dewatering flow rate values were calculated.

### 25.6.3 Mine Design

The Quemont No. 2 shaft will be rehabilitated to accommodate an approximate LOM average production rate of 15,500 tpd and will provide the principal access to the deposit. The shaft is designed to operate two 43 t skips, one double-deck service cage, one double-deck auxiliary cage and services for the underground mine. The hoisting capacity of the rehabilitated shaft is 23,180 tpd for Phase 1 and 16,530 tpd for Phase 2. The shaft design calls for the rehabilitation of 24 existing stations, five of which will be used during production. Upon completion of shaft deepening, an additional five stations will be built. A total of ten stations will be used in mine Phases 1 and 2.

Four main levels connect the Quemont No. 2 shaft and Horne 5, and production levels are connected by a main decline from the top to the bottom of the deposit. The proposed mine plan for the Horne 5 Project is divided into two production phases characterized by separate accesses to the mineralized zones:

- Phase 1: From surface to level 1310, near the bottom of the current Quemont No. 2 shaft, located on level 1230;
- Phase 2: From level 1340 to level 2060, after deepening the Quemont No. 2 shaft.

A fleet of 14 t LHDs and 55 t trucks will be required for underground infrastructure development.

For excavation, automated 21 t LHDs will dump directly from stope to ore pass; two main ore passes will then transfer material from the production area to two loading stations on levels 1180 and 1910.

For each phase, the ore passes will be connected to grizzlies and rock breaker facilities, which then lead to two primary crushers for Phase 1 and one primary crusher in Phase 2. In both cases the crusher product feeds a single conveyor that transports the ore from the Horne 5 mine to the Quemont No. 2 shaft loading facilities. Below level 1910, 55 t trucks will be used for haulage in the main ramp from level 2060 to level 1910.

Key mine infrastructure includes a paste backfill distribution network, five main pumping stations, a fuel distribution network, a main garage for equipment, electrical substations and other installations such as powder magazines and refuges.

Three master communication networks will be installed from surface to every underground level. The first is a leaky feeder cable to provide voice communication throughout the mine, the second is the “FEMCO” security system deployed at every refuge and strategic site, and the third is the fiber optic network that will be brought to every electrical substation, pump station, crushing station and conveying site. Each level will have Wi-Fi distribution and a network access point through the leaky feeder network.

#### 25.6.4 Mine Dewatering and Rehabilitation

Dewatering from surface will be first done from the Horne No. 4 shaft, Quemont No. 2 shaft and Donalda shaft collars. Several submersible, high-volume, high-pressure stainless steel pumps will be required to remove water from the historical mines. These pumps can be remotely lowered down the shafts without any installation in each of the shafts. In each case, a surface set-up will manage the submersible pumps. The pumps will be dropped down in the shaft to a depth between 100 m and 375 m from the shaft collar. The combined water pumping rate sent to the WTP at surface will be a maximum of 600 m<sup>3</sup>/h.

- The Horne No. 4 shaft installation consist of two 400 hp submersible pumps that are installed from the surface to a maximum of 230 m deep with a rigid piping set-up;
- Quemont No. 2 shaft installation consists of one 400 hp submersible pump to a depth of 275 m;
- Donalda shaft installation consists of one 250 hp submersible pump to a depth of 375 m.

Once Quemont No. 2 shaft has been dewatered down to level Q275 by mean of the surface installation, new submersible pumps will be installed underneath the Galloway, a multi-decked platform, to follow the rehabilitation of the shaft. Two 150 hp stainless steel submersible pumps will feed a 500 hp multistage pump, installed directly on the Galloway deck, to direct the water to surface or to the permanent underground pumping stations, as they are installed.

All permanent installations for dewatering will be set up near the Quemont No. 2 shaft. As soon as the levels Q275 (connecting with L322), Q715 (connecting with L774) and Q1180 (connecting with L1194) are reached, the main clear water pumping stations will be built as a priority to support and contribute to the dewatering of Quemont and Horne mines. As the Galloway is lowered and the Quemont No. 2 shaft is dewatered and rehabilitated, the main pumping stations will be used as boosters to bring the water to surface, as they become available.

Drainage holes will be used to dewater the historical Horne mine via the Quemont No. 2 shaft and the installed pumping infrastructure. Drilling bays will be used to drain Horne water to the Quemont main pumping station. This system will securely drain high-pressure water by drilling 3 in diameter holes about 250 m to reach historical Horne openings. The water from these drain holes will be directed to sumps and then pumped to the main pumping stations by mean of submersible pumps.

During the various phases of dewatering, four hydrostatic plugs, designed for a maximum head pressure at their location, will be remotely built to isolate the various mines. The placement and mix designs are based on submerged construction, once dewatered the concrete delivery holes will be re-drilled through the plug and into the floor in order to grout the area.

### 25.6.5 Mine Services

Mine services include underground electrical distribution, automation and monitoring systems, fuel distribution, mine dewatering network and a ventilation network.

The ventilation system is a push-pull system. Permanent main fans on level 322 will provide fresh air to the mine. Fans in the headframe will feed the shaft to lower global pressure in the infrastructure. A total of 800,000 cfm is required for the mining operation. During preproduction, the old Quemont ventilation raise will be reused for development start-up. Two natural gas heating systems will be used during the winter months. VOD will be implemented to maximize the use of ventilation in working areas and thus lower requirements in other areas to help reduce energy costs.

### 25.6.6 Cemented Paste Backfill

Tailings will be used as cemented paste backfill for structural support in the Horne 5 mined-out stopes during production. Cemented paste backfill will also be used to backfill some of the old Horne mine on the levels where the Horne 5 development and mining activities will be intersecting the old Horne drifts and voids. PFT, PCT and a pre-mix of cement and blast furnace slag will be used to produce the paste backfill for the underground mining operation. The estimated volumes of cemented paste backfill required are 0.46 Mm<sup>3</sup> and 0.18 Mm<sup>3</sup> for Phases 1 and 2, respectively. Over the life of mine of the Project, the use of cemented paste backfill will allow the backfilling of approximately 45% of all the tailings produced and specifically, 61% of the pyrite concentrated tailings.

Two key aspects that influence the design of the underground distribution systems are the capacity of the paste plant and the mix recipe. The plant capacity will determine the flow rates for all of the process streams, whereas the mix recipe is determined to achieve the required backfill strength at the lowest binder content while maintaining a material that can be pumped or delivered by gravity.

The plant capacity selected for the Horne 5 Project is based upon the use of approximately 12,065 tpd tailings for the backfilling of mining voids generated by ore extraction in any given year. Such plant capacity allows an overall plant utilization of approximately 60%, which is typical for a paste backfill operation. Because the Horne 5 orebody is mostly dipping vertically, it is possible to distribute the paste by gravity and avoid the operation of a pumping system.

Extensive laboratory testing was completed to determine the optimal recipe to meet the geotechnical strength requirements. Laboratory tests on tailings performed by Golder and *Unité de recherche et de services en technologie minérale* (“URSTM”) confirmed that a mixture comprised of 50% PFT / 50% PCT at a 200 mm (8 in) slump was an appropriate mix design when using 80% blast furnace slag and 20% general use cement as the binder agent.

The paste plant design will include two parallel circuits and as a result, the paste backfill underground distribution system (“UDS”) is based upon operating a distribution line for each of the circuits. All piping and boreholes will be twinned for the paste distribution system. Redundancy will also be built into the system; thus, four boreholes will be drilled from surface to underground. For all interconnecting underground boreholes there will also be four boreholes; two operating and a spare for each.

### 25.6.7 Production Plan

Developing and maintaining access to sufficient resources to sustain the approximate 15,500 tpd average over the LOM production sequence will require an extensive underground development program averaging 7,000 m per year of jumbo advance, with a peak of 13,700 m in the final year of construction. A total of 129,100 m of lateral development will be required during the life of the mine.

The preproduction period will require 36 months from the onset of mine development, including the dewatering and rehabilitation sequence. Waste rock generated through infrastructure development will be disposed of in underground stopes, except during the preproduction period, where a portion of the waste rock will be transported to the TMF site and used as construction material. A total of 1.5 Mt of waste will be hoisted during that time.

Production will start in the third quarter of 2021 with a gradual ramp-up leading to full production in the beginning of 2022. Full production will continue until 2034. Production will then drop below 12,000 tpd in 2035 upon depletion of Phase 2.

- Phase 1 will run from 2021 to 2029;
- Phase 2 will run from 2028 to 2035.

A total of 81 Mt of ore, including development, will be hoisted over the life of the mine, at an average grade of 1.44 g/t Au, 0.17% Cu, 0.77 % Zn and 14.14 g/t Ag.

### 25.6.8 High Density Sludge (HDS) Distribution

During dewatering of historical mines (Donalda, Quemont and Horne), the water treatment process will generate sludge that will be pumped back in a densified form (HDS) into historical voids of Donalda and Quemont via pipelines and boreholes. At the Quemont mine, active areas used for the Horne 5 operation will be isolated from sludge disposal areas with hydrostatic barricades. These barricades are designed considering connections between levels and to support full hydraulic head. Thickening and settling behaviour of HDS is based on assumptions that would need to be confirmed by testing of samples from water collected at site.

### 25.6.9 Slurry Tailings Distribution

Tailings in excess of the cemented paste backfill needs for operation or generated while the paste backfill plant is not operating will be stored in old Horne mine openings as slurry. Based on the underground storage capacity estimation, tailings will be stored underground for approximately 2 years. The remainder will be stored in a surface TMF. The majority of the Horne mine voids are located in the upper part of the mine. In order to safely discharge tailings slurry in Horne mine, the Horne 5 mine will be isolated from the Horne mine with a plug of cemented paste backfill. The plug of paste above the Horne 5 mine will extend vertically for approximately 250 m and bleed water will be captured and pumped to the process plant using the underground mine dewatering system. The remaining existing former drifts and voids close to mining activities will also be backfilled with cemented paste backfill during the development of the Horne 5 mine. The tailings slurry underground distribution system was designed to handle the required production rates, it is planned as a combination of pipelines and boreholes reaching each levels. The voids that will be filled with tailings will start from HL436 and move upwards. Levels HL360 to HL436 will be backfilled with slurry from boreholes from the rehabilitated HL322 and levels HL53 to HL322 will be backfilled from the surface on the Third Party's property. The backfilling of tailings slurry in the former Horne mine represents approximately 7% of all the tailings produced during the planned life of the Project.

### 25.6.10 Mine Equipment and Personnel

The mine will operate seven days a week, night and day (24/7). Up to 333 people will be required for the production years (Phase 1), comprising 57 staff employees and 276 hourly employees. It is estimated that approximately 325 people will be required when the surface tailings management facility is in operation.

A complete fleet of equipment will be needed to support mine operations and meet productivity requirements. A total of 77 units of mobile equipment are listed in this FS. Production equipment, such as production drills, LHDs and trucks, will be automated.

## 25.7 Metallurgy and Processing

### 25.7.1 Metallurgical Testwork

The key results from the metallurgical testwork are as follows:

- The metallurgical projections were established with flotation testwork completed on various samples obtained from drill holes of the 2015-2016 exploration campaign, within the PEA stage scope, and on the three phases of testing completed in 2016-2017 to upgrade to FS level.
- The mineralogy of gold in the samples was shown to be quite variable, with tellurides and various Au-Ag ratios in electrum-like minerals being present. All gold grains were found to be quite fine, preventing inclusion of gravimetric recovery processes.
- The grinding circuit configuration and sizing of the mills benefited from a strong inverse correlation linking the sulphur content of the material to the grindability indices measured, as well as to SG and Ai. Such correlations alleviated the need to track the rock type and prevented a potential bias from selecting a design ore based on a percentile of the population of grinding indices measurements: the design ore was thus defined from the sulphur distribution in the blocks of the geological model and the resulting value then used to calculate from the regression equations the appropriate grinding index values.
- Restrictions on the particle top size of the samples made available for grinding testwork prevented a direct measurement of the expected power demand for SAG milling. The total grinding power was derived using an indirect but established methodology, out of which SAG power is obtained by deducting from the total power demand what is ascribed for ball milling.
- The silver-to-gold ratio is quite high in the samples tested: the expected gold load on the carbon is shown at less than 15% of the overall metal loading. At these ratios, a Merrill-Crowe circuit for recovering dissolved gold and silver may be more cost-effective than the CIP circuits currently proposed due to stripping costs and accelerated carbon wear. On the other hand, the large footprint for multiple solid-liquid separation units and operation of such in a Nordic environment may present challenges.
- Fine regrinding of the pyrite concentrate stream is required prior to leaching. Regrinding is to be performed in HIG mills, which have demonstrated a good energy efficiency and lower CAPEX. The limited installation base, especially for the large units contemplated and with none of them used in an abrasive grinding environment, will require some modifications to the basic design offered to date by the manufacturer. These should result in more straightforward maintenance procedures, allowing for an appropriate availability to be achieved.
- The fast leaching kinetics exhibited for gold may allow for the conversion of the leach-CIP configuration into a CIL circuit. The expected reduction in CAPEX may also provide some OPEX relief, albeit at the cost of incremental solution losses and in-process gold and carbon inventories. A trade-off study is recommended.

## 25.7.2 Process Flowsheet

Based on the testwork conducted, the process flowsheet consists of primary and secondary grinding stages of the crushed ROM material, followed by three flotation stages producing saleable copper and zinc concentrates and generating a pyrite concentrate and flotation tailings streams. The pyrite flotation concentrate undergoes a regrind and leaching to recover gold and silver. The overall gold and silver recoveries are increased by also leaching the pyrite flotation tailings. Both the leached pyrite flotation concentrate and pyrite flotation tailings are treated in separate CIP and cyanide destruction circuits. As required to suit the mining sequence, the thickened tailings are pumped to the paste backfill plant for further dewatering and binder addition before being sent underground. The thickened tails, as produced above the paste backfill requirements or when said preparation circuit is not operated, are sent underground as hydraulic fill in the first years of operation. Later, when the historical voids of the Horne mine will have been filled, a surface TMF will be used for storage.

The configuration of the individual circuits and major equipment proposed are of conventional design. Exception to this resides in the inclusion of large HIG mills for covering the regrinding duty. The 5 MW units are used in operations elsewhere but only in duties with low maintenance requirements, stemming from the low abrasiveness and hardness of the industrial minerals typically processed at such sites.

## 25.7.3 Metal Recovery Projections

Based on the proposed flowsheet, the overall projected metallurgical recovery and net payable values for gold, silver, copper and zinc from the Horne 5 deposit are presented in Table 25-4.

**Table 25-4: Projected metallurgical recoveries and net payable values for Au, Ag, Cu and Zn**

Stage	Product	Cu (%)	Zn (%)	Au (%)	Ag (%)
Flotation	Cu concentrate	81.9	4.5	40.0	32.2
	Zn concentrate	-	86.2	1.7	11.7
	Py concentrate	-	-	52.3	47.5
	Py tails	-	-	6.1	8.6
Leaching	Py concentrate	-	-	85.0	77.6
	Py tailings	-	-	78.6	65.2
<b>Overall Metallurgical Recovery (%)<sup>(1)</sup></b>		<b>81.9</b>	<b>86.2</b>	<b>90.9</b>	<b>85.1</b>
<b>Net Payable (%)<sup>(2)</sup></b>		<b>75.8</b>	<b>72.9</b>	<b>88.1</b>	<b>71.5</b>

<sup>(1)</sup> Metallurgical recovery based on LOM averages of yearly projections, including payable metal deportment to saleable concentrates and doré from leaching.

<sup>(2)</sup> Net payable percentages reflect payments and deductions for smelting and refining in the NSR estimate, without concentrate transportation losses.



#### 25.7.4 Process Plant Personnel

A total of 93 workers are required in the process plant (with paste backfill), including 34 salaried staff and 59 hourly workers divided into management, technical services, operations and maintenance departments. An allowance for contractors was also included for OPEX calculations.

#### 25.8 Environment and Site Restoration

Environmental baseline studies have been initiated in 2016 and are continuing throughout 2017 to support the EIA permitting process in accordance with the Horne 5 Project timeline.

The Horne 5 Project will require a provincial and federal decree. The project is subject to a provincial impact assessment study as forecasted production is over the 2,000 tonnes per day threshold outlined in the applicable regulation. The Project will also be subject to a federal impact assessment study.

The CoA under Sections 22 and 31.75 of the Environmental Quality Act was issued by the MDDELCC in 2016 for the dewatering of the two first levels of the Quemont No. 2 shaft. However, a new application for a CoA was submitted in July 2017 to support Falco's revised dewatering and sludge management strategy.

Site restoration costs are estimated at \$87.2M. The site restoration cost estimate for the Horne 5 Project is based essentially on the dismantling the mine's buildings at the Quemont site and the restoration of the surface TMF site. Falco intends to dismantle all buildings that will have served its mining operations. Given the proximity of the site to the city, some buildings could be reused or modified for other uses. As required by the MERN, this cost estimate includes the cost of site restoration, the post-closure monitoring as well as engineering costs (30%) and a contingency of 15%. In accordance with the regulations, Falco intends to post a bond as a guarantee against the site restoration cost.

#### 25.9 Waste Rock and Tailings Management

The most notable outcomes from the work performed on the waste rock and tailings management aspects of the Horne 5 Project are as follows:

- The best tailings management strategy was identified as being the one that allows maximizing storage of tailings underground in addition of paste backfill;
- Waste rock, ore and tailings are potentially acid generating and will require a management strategy on surface that will meet the recommendations of Directive 019. The PFT are potentially acid generating but report low sulphur content and have not developed acidic conditions in laboratory weathering tests, so a delay in the onset of acidic conditions can be expected.

- The old Norbec Mine area has been identified as the most suitable site for the development of the surface TMF of the Project. The site selection study outcome, including a multiple-account analyses, showed that prioritizing the use of an old and already impacted mine site along with finding a suitable area for development from environmental, technical and social point of views played an important role;
- Staged construction and operation of the TMF is proposed starting in 2022. Operation of the TMF is planned to start in Q2 2023;
- PCT and PFT will be managed separately given their geochemical and grainsize characteristics. The TMF will thus consist of two separate cells namely, PCT Cell and PFT Cell, and two main water ponds: the Internal Pond and the Polishing Pond;
- Overall, the TMF will be developed and operated according to five main stages. Stages 1 through 4 will use the same Polishing Pond while in stage 5, if optimization based on real performance data on deposition confirms the necessity of it, a new smaller polishing pond will be built downstream of the original one;
- TMF PCT Cell design concept is based on using a geosynthetic liner for underlining and covering the PCT. A pumping system integrated in the cell operation will be provided for draining the tailings water during operation and active closure;
- TMF PFT Cell design concept is based on providing a continuous drainage feature, the internal pond, built with permeable materials to lower the phreatic surface in the tailings mass and to be used as water intake for recovering contact water to the process plant or to transferring the excess water to the water treatment plant at the TMF. Closure of the PFT Cell will consist in applying an appropriate cover system for long term limitation of water infiltration and in converting the internal pond to a permanent drainage feature;
- TMF construction and operation involves building two relatively small water diversion systems for operation and one larger one for diverting Vauze Lake, located upstream of the TMF, at closure.

## 25.10 Water Management and Treatment

Numerous activities related to water management were performed as part of the FS. The following details the most critical activities:

- Updated the annual water balance to take into account the changes to the strategy in terms of tailings and sludge management in order to limit project costs;
- Verified water requirements at each phase of the LOM and determined ways to minimize the impact on the environment to fulfill the shortfall and to release the excess water;
- Refined the surface water management plan at the Horne 5 Mining Complex by integrating it with the layout of the process plant infrastructure, and propose a final topography for the site in order to limit surface water management infrastructure costs;

- Refined the surface water management plan for the TMF by integrating it to the five stages of development, including delaying construction costs.

Significant conclusions from the water quality assessment work include:

- Underground water quality is anticipated to be acidic with elevated sulphate and metals concentrations, and potentially elevated thiosalts and ammonia concentrations, with pH levels and iron and zinc concentrations exceeding the Québec Effluent Criteria of Directive 019. These parameters will require treatment for dewatering and mine operations.
- Based on the preliminary TMF water quality model results, the inflow to the water treatment plant at the TMF is anticipated to be acidic, and has elevated sulphate, iron, and zinc concentrations. TMF effluent will require treatment to meet effluent criteria.
- Based on the preliminary mine site water quality model, the inflow to the process plant (process water tank) is anticipated to be neutral, and, depending on the treatment efficiency achieved, it could contain elevated concentrations of sulphate, nitrate/nitrite, total cyanide, copper and zinc.
- Cyanide destruction testing using Caro's Acid did not reduce the total cyanide concentration in process water to concentrations below the Québec Effluent Criteria of Directive 019. Final water treatment will be conducted at the effluent water treatment plant.

Activities related to water treatment for the FS included:

- Treatability testing was conducted on the water sampled in the historical Quemont mine and treatability and pilot testing will be conducted for the water sampled from the REMNOR shaft;
- Water treatment design was based on treatability testing and adjusted to the water quality results obtained from the historical Horne (REMNOR shaft) mine, combined with full scale operational results from an analog HDS project having similar water quality;
- The capital investments were reduced by including some equipment in the preproduction water treatment design that are subsequently required for the process plant;
- A strategy was established for storing the HDS, resulting from dewatering and treatment, in underground voids at Donalda and Quemont mines.

Water treatment will be required at both the Horne 5 Mining Complex and the TMF site. A prime component of the water treatment systems is the treatment of excess water during the preproduction phase, during which the flooded historical mine workings will be dewatered. Water treatment will continue through the production phase to ensure that the required discharge conditions are met.

Water treatment will consist of metals, sulphate and polythionate removal as well as pH adjustment for all phases of the Horne 5 Project, combined with residual cyanide removal, once production begins at the process plant. Ammonia treatment by pH adjustment is anticipated to be required for a portion of the preproduction period. The metals and sulphate treatment systems will

produce by-product HDS, which will then be stored in the historical mine workings during preproduction and suitable for management with tailings during production.

A temporary WTP with a 600 m<sup>3</sup>/hr capacity will be built to treat water from the historical mines during the preproduction phase. Treated water from the treatment plant will be discharged into the Dallaire watercourse. As the mine enters the production phase, the temporary water treatment plant will be shut down and the equipment will be dismantled and repurposed to be used as part of the process plant's cyanide destruction, concentrate and tailings dewatering as well as lime storage circuits.

## 25.11 Infrastructure

The Horne 5 surface infrastructure spans over two principal sites: the Horne 5 Mining Complex (former Quemont mine site) and the Tailings Management Facility (former Norbec tailings facility), which is located approximately 11 km to the northwest. The two sites will be connected via pipelines to allow for tailings disposal and water reclaim.

In order to develop the Project as described in this Report, the following site infrastructure and services will be constructed:

- Site access and site roads;
- On-site control gate house and parking area;
- 120 kV overhead transmission line from the Hydro-Québec Rouyn Noranda substation to the Project site (2 km);
- 120 kV to 25 kV Horne 5 outdoor main substation;
- Headframe, hoist room and surface material handling system;
- Process plant including paste backfill plant;
- Warehouse and service building (existing Sani-Tri building);
- Mine office and dry building (existing *Centre de Formation Quemont* building);
- First-Aid/Emergency services;
- Administration building (existing Lamothe building);
- Railway spur lines and siding storage tracks;
- Electrical distribution and communication infrastructure;
- Fuel storage;
- Site utilities;
- Community infrastructure (including industrial and institutional relocation);
- Surface tailings and water management facility infrastructure and pipelines;
- Water treatment facilities and slurry management pipelines;
- Fresh water pump house and pipelines.

---

## 25.12 Market Studies and Contracts

Testwork assays from flotation trials served to provide typical grades of valuable metals and undesired impurities. The suitability of the typical zinc and copper concentrates to be produced at the Horne 5 Mining Complex were evaluated with regards to smelter capabilities.

The zinc concentrate produced is suitable for most smelters. However, as the zinc concentrate has a precious metal content, smelter recovery capabilities or lack thereof and differential transportation costs and smelter's price participation with respect to these will play an important role in negotiations with potential buyers. The copper-gold concentrate will be suitable for copper smelters within the region of the Horne 5 Mining Complex. Although the copper levels present are lower than typical copper concentrates, the treated high levels of gold and silver will make the concentrate attractive to buyers. The copper and zinc concentrates are both clean with respect to typical deleterious elements; however, minor penalties may be imposed due to the presence of other impurities.

Glencore Canada has rights of first refusal with respect to purchase or toll process all or any portion of the concentrates and other mineral products from the Horne 5 Project.

The net payable metal contents as detailed in Table 25-5, were derived by applying the yearly mass balance and recoveries and smelting contract assumptions.

Estimated logistics costs for the movement of concentrates to various destinations were obtained from select service providers. The transport and logistics values used for the copper concentrate is 93.40 \$/t and 89.26 \$/t for the zinc concentrate.

The costs associated with the treatment and refining ("TC/RC") for the copper and zinc concentrates were calculated as being 2.00 USD/t and 4.25 USD/t respectively.

Table 25-5: Calculation of net payable metal content in products

Product	Flotation Rec. (%)	Leach Rec. <sup>(1)</sup> (%)	Payable (%)	Net Paid (% LOM)
<b>Au</b>				
Cu concentrate	40.0	n/a	97.0	38.7
Zn concentrate	1.7	n/a	0	0
Py concentrate	52.2	85.0	100.0	44.7
Py tails	6.1	78.6	100.0	4.7
<b>TOTAL</b>	<b>100.0</b>		<b>96.9</b>	<b>88.1</b>
<b>Ag</b>				
Cu concentrate	32.2	n/a	89.9	29.0
Zn concentrate	11.7	n/a	0.0	0.0
Py concentrate	47.5	77.6	100.0	36.9
Py tails	8.6	65.2	100.0	5.6
<b>TOTAL</b>	<b>100.0</b>		<b>84.0</b>	<b>71.5</b>
<b>Cu</b>				
Cu concentrate	<b>81.9</b>	n/a	92.5	<b>75.8</b>
<b>Zn</b>				
Zn concentrate	<b>86.2</b>	n/a	84.6	<b>72.9</b>

<sup>(1)</sup> Including CIP solution losses.

As of the effective date of this Report, no contracts are in place for any production from the Horne 5 Mining Complex. A number of contracts have been awarded as part of the pre-construction activities of the Project. These contracts are related to overall engineering, procurement, supply, performance services and installation of the Mine hoisting systems as well as mine hoist frame engineering, mine watering engineering and major mine dewatering equipment.

### 25.13 Capital Costs

The total capital cost of the Horne 5 Project, including preproduction and sustaining costs, is estimated at \$1.597B. The preproduction costs were calculated at \$1.062B, including a \$75.0M contingency. The sustaining costs, excluding site rehabilitation costs, were calculated at \$535M. Sunk costs of \$34.3M have been committed to date. Site rehabilitation and closure costs are estimated at \$87.2M.

The overall capital cost estimate developed in this Study meets the AACE International (“AACE”) Class 3 estimate requirements and has an accuracy range of -10% and +15%. The capital cost estimate was compiled using a combination of quotations (budgetary and fixed price), database costs, and database factors. Items such as sales taxes, certain land acquisition, permitting, licensing, price escalation, development studies and financing costs are not included in the cost estimate. The Horne 5 Project capital cost summary is outlined in Table 25-6.

Table 25-6: Project capital costs (preproduction and sustaining)

WBS	Cost Area	Preproduction Capital Cost (\$M)	Sustaining Capital Cost (\$M)	Total Cost (\$M)
000	General Administration	47.2		47.2
200	Underground Mine	256.9	325.1	582.0
300	Mine Surface Facilities	81.8	4.7	86.5
400	Electrical & Communication	18.3	2.3	20.5
500	Site Infrastructure	13.2	-	13.2
600	Processing	379.4	13.0	392.5
700	Community Infrastructure and Relocation	36.1	-	36.1
800	Tailings and Water Management	68.5	190.3	258.7
900	Indirects	85.8	-	85.8
999	Contingency	75.0	-	75.0
	<b>Total</b>	<b>1,062.1</b>	<b>535.4</b>	<b>1,597.5</b>
	Less Outlays to August 31, 2017	(34.3)	-	(34.3)
	Site Reclamation and Closure	-	87.2	87.2
	Salvage Value	-	(45.0)	(45.0)
	<b>Total – Forecast to Spend</b>	<b>1,027.8</b>	<b>577.5</b>	<b>1,605.4</b>

(1) Sustaining costs include construction indirects and contingency

## 25.14 Operating Costs

The operating cost estimate (“OPEX”) is based on a combination of experience, reference project, budgetary quotes and factors as appropriate with a feasibility study. The target accuracy of the operating cost is  $\pm 10\%$ . No cost escalation or contingency has been included within the operating cost estimate.

The operating cost estimate in this FS includes the costs to mine, process the mineralized material to produce copper and zinc concentrates, gold doré, and tailings as well as water treatment and general and administration expenses (“G&A”).



The average operating cost over the LOM is estimated to be 41.00 \$/t milled. Total LOM and unit operating cost estimates are summarized in Table 25-7.

Table 25-7: Project operating costs

Cost Area Description	LOM Total \$M	Average LOM (\$M/Year)	Average LOM (\$/tonne)	OPEX (%)
Mining	1,020	68	12.60	31
Processing	1,654	110	20.45	50
Tailings and Water Management	411	27	5.08	12
General and Administration	231	15	2.86	7
<b>Total</b>	<b>3,316</b>	<b>221</b>	<b>41.00</b>	<b>100</b>

It is anticipated that 502 employees (staff and labour) will be required for operations. Table 25-8 provides a summary of the employees by facility area.

Table 25-8: Personnel summary – all areas

Facility Area	Number of Employees
Underground Mine <sup>(2)</sup>	325
Process Plant (Including Paste Plant)	93
Tailings, Water Treatment and Environment <sup>(1)</sup>	22
General and Administration	62
<b>Total– Horne 5 Mining Complex</b>	<b>502</b>

<sup>(1)</sup> Total includes employees required by the surface Tailings Management Facility.

<sup>(2)</sup> Total does not include employees for underground tailings service prior to the surface TMF operations.

## 25.15 Indicative Economic Results

The economic/financial assessment of the Horne 5 Project was carried out using a discounted cash flow approach on a pre-tax and after-tax basis, based on Q3-2017 metal price projections in U.S. currency and cost estimates (CAPEX and OPEX) in Canadian currency. Inflation or cost escalation factors were not taken into account. An exchange rate of 0.78 USD for 1.00 CAD has been assumed over the life of the Horne 5 Project. The base case gold, silver, copper and zinc prices are 1,300 USD/oz., 19.50 USD/oz., 3.00 USD/lb and 1.10 USD/lb, respectively.

Over the LOM approximately 3.294 Moz Au, 26.3 Moz Ag, 229 Mlbs Cu and 1,007 Mlbs Zn will be produced on a payable basis.

The pre-tax base case financial model resulted in an IRR of 18.9% and a NPV of \$1,297M using a 5% discount rate. The pre-tax payback period is 5.2 years.

On an after-tax basis, the base case financial model resulted in an IRR of 15.3% and a NPV of \$772 M using a 5% discount rate. The after-tax payback period is 5.6 years.

The LOM operating cash cost per ounce (Including by-product credits) is 260 USD/oz Au. The LOM cost all-in sustaining cost (“AISC”) per ounce is 399 USD/oz Au derived from the total cash costs plus sustaining capital, and closure costs. The operating margin (including by-product credits) over the LOM has been estimated to be 901 \$/oz Au based on a gold price of 1,300 USD/oz.

## 25.16 Execution Plan and Schedule

The execution of the Horne 5 Project will be directly managed by the Falco construction management team. The engineering and construction works will be contracted out to qualified firms and contractors under the direct supervision of Falco. Procurement and project control functions such as scheduling, cost control, project logistics and site supervision will be executed directly by Falco personnel.

The preliminary on-site workforce requirement for construction, including infrastructure, process plant, and development of the underground mine is expected to peak at approximately 950 individuals.

Pending the completion of all studies and receipt of the required permits, construction of the process plant is scheduled to begin in mid-2019 with the objective of achieving full production capacity in H2 2021. Full mine production will follow in H1 2022. Construction of the planned surface tailings management facility will begin in Q2 2022 to be operational for Q2 2023.

## 25.17 Project Risks and Opportunities

As with most mining projects, there are risks that could affect the economic viability of the Project. Many of these risks are based on a lack of detailed knowledge and can be managed as more sampling, testing, design, and engineering are conducted at the stage of the Project. Table 25-9 identifies what are currently deemed to be the most significant internal project risks, potential impacts, and possible mitigation approaches that could affect the technical feasibility and economic outcome of the Project.

The most significant potential risks associated with the Horne 5 Project are not coming to an satisfactory agreement with third parties to access and operate the site, uncontrolled dilution due to geotechnical parameters, underestimation of underground mine tailings storage volumes, lower metal recoveries than those projected, operating and capital cost escalation, permitting and environmental compliance, unforeseen schedule delays, changes in regulatory requirements, and ability to raise financing. Many of previously noted risks can be mitigated with adequate engineering, planning and pro-active management.

External risks are, to a certain extent, beyond the control of the Project proponents and are much more difficult to anticipate and mitigate, although, in many instances, some risk reduction can be achieved. External risks are things such as the political situation in the Project region, metal prices, exchange rates and government legislation. These external risks are generally applicable to all mining projects. Negative variance to these items from the assumptions made in the economic model would reduce the profitability of the mine and the mineral resource estimates (refer to Table 25-9).

There are significant opportunities that could improve the economics, timing, and/or permitting potential of the Project. The major opportunities that have been identified at this time are summarized in Table 25-10 excluding those typical to all mining projects, such as changes in metal prices, exchange rates, etc. Further information and assessments are needed before these opportunities can be included in the project economics.

Table 25-9: Project risks (preliminary risk assessment)

Area	Risk and Potential Impact	Mitigation Approach
<b>Geology and Mineral Resource</b>	<ol style="list-style-type: none"> <li>1. Lower grades due to local inaccuracies could reduce the metal content and recovery.</li> <li>2. Metal recoveries could be lower than expected resulting in lower mineral resource estimate than planned.</li> </ol>	<ol style="list-style-type: none"> <li>1. Selection of adapted mining and processing approach.</li> <li>2. Add relevant historical information from drill holes to the current database and conduct additional metallurgical tests.</li> </ol>
<b>Underground Mining</b>	<ol style="list-style-type: none"> <li>1. Changes to currently established geotechnical parameters could affect stope dimensions, pillar recovery, ground support, mining and development sequences, and dilution and recovery, all of which could negatively affect the project economics.</li> <li>2. The rupture of a hydrostatic plug, unexpected stope drainage or stope fence failure during the preproduction and production period could cause a sudden influx of water into the work area.</li> <li>3. With the effect of acid drainage, the old shaft set, wood and steel installations along with ground support in the mine could be damaged, corroded and unsafe.</li> <li>4. As dewatering progresses, gas may buildup suddenly from stopes and captive areas.</li> <li>5. Unexpected voids may be encountered during mine development.</li> <li>6. Inability to achieve production target with new technologies leading to higher operating costs.</li> </ol>	<ol style="list-style-type: none"> <li>1. Additional mine design, geotechnical investigations, and simulation work.</li> <li>2. For this reason, during the shaft rehabilitation, the water level is always maintained one level below the work area to create a buffer and provide enough time to evacuate the workers in case of a sudden incursion. During production, continuous monitoring of the water level and inspection of the existing plugs would also contribute to a safer environment.</li> <li>3. Using a Galloway in the shaft will provide safe access to the work area. As dewatering progresses, the shafts, stations and levels will be secured according to today's safety standards for open holes and construction work.</li> <li>4. For this reason, proper ventilation is needed in the work area, and the water level should be lowered ahead of the work area. The plan is to reuse the old ventilation network for the rehabilitation and dewatering phase, combined with secondary fans providing fresh air to the work face.</li> <li>5. Before starting the dewatering process, the old mine plans, sections and any other available information should be reviewed thoroughly to identify any unexpected drifts, construction, open holes or raises in advance.</li> <li>6. Gain better knowledge on suitable proven technologies via site visits and technology transfers.</li> </ol>

Area	Risk and Potential Impact	Mitigation Approach
<p><b>Geotechnical Considerations</b></p>	<ol style="list-style-type: none"> <li>1. Once underground, the rock mass behaviour could be different than expected and influence stope dimensions, pillar recovery, ground support, mining and development sequences, and dilution and recovery. These could negatively affect the Project economics.                             <ol style="list-style-type: none"> <li>a. Secondary stopes do not yield as forecasted when the primary stopes are mined resulting in slower and less reliable production.</li> <li>b. Planned mitigation measures for extracting sill pillars may not be sufficient (e.g. sill pillars do not yield as forecasted prior to mining) resulting in slower and less reliable production.</li> <li>c. Planned destressing of the dike area and/or of the converging mining front is not as efficient as expected resulting in mining in highly stressed ground in those areas.</li> </ol> </li> <li>2. Operational challenges due to mining in highly stressed ground are expected for the lead stopes to be mined at a sill pillar level.</li> <li>3. Conditions and/or location of historical openings and infrastructure are not as anticipated leading to higher costs and schedule delays.</li> <li>4. Geological structures have not been explicitly taken into account in the mine design and could impact the mining sequence and production.                             <ol style="list-style-type: none"> <li>a. Faults could possibly contribute to create a water pathway between the historical Horne mine and the Horne 5 Project.</li> <li>b. Small scale faults could have an impact on local stope stability and have potential for generating rockbursts (e.g., fault-slip).</li> </ol> </li> <li>5. Conditions in the footwall drifts planned in the ore are worse than expected.</li> </ol>	<ol style="list-style-type: none"> <li>1. Gather additional geotechnical data as mining starts, confirm rock mass properties and assumptions made during the FS, calibrate existing numerical stress models and review mine design.</li> <li>2. An ore recovery value based on engineering judgement was assigned to each sill pillar to reflect assumed operational challenges.</li> <li>3. Higher binder content (5%) is planned for stopes in the vicinity of the historical Horne mine. The standoff distance (currently 15 m) could change depending on the conditions observed once underground.</li> <li>4. Secondary major faults should be considered for planning during detailed design and construction.</li> <li>5. Footwall drifts may need to be excavated outside the orebody at the operationally constrained standoff distance.</li> </ol>

Area	Risk and Potential Impact	Mitigation Approach
<p><b>Mine Shaft</b></p>	<ol style="list-style-type: none"> <li>1. Condition of the existing shaft and stations may be worse than expected causing delay for rehabilitation.</li> <li>2. Shaft guide misalignment reducing the skip operating speed.</li> <li>3. Water acidity increasing infrastructure wear leading to higher maintenance requirements (higher OPEX).</li> </ol>	<ol style="list-style-type: none"> <li>1. Good shaft rehabilitation planning and methodology will be implemented thus allowing for flexibility in case of bad existing infrastructure condition.</li> <li>2. Shaft steel sets designed for high speed skip operation will be installed, reducing the impact of guide misalignment.</li> <li>3. Automation of guide alignment inspection to prevent potential failures. All underground infrastructures are designed in galvanized steel.</li> </ol>
<p><b>Hoist and headframe</b></p>	<ol style="list-style-type: none"> <li>1. Lower hoist availability due to maintenance or inspection requirements reducing the hoisting capacity.</li> <li>2. Rope life shorter than expected due to high payload and great depth leading to higher downtime and higher OPEX.</li> <li>3. Winter construction may be required to respect schedule leading to higher CAPEX.</li> </ol>	<ol style="list-style-type: none"> <li>1. Good maintenance and inspection planning reducing the hoist down time. Hoisting capacity designed for 16,530 tpd which is larger than the required production rate allowing operational flexibility.</li> <li>2. Automation of inspection and maintenance such as rope inspections and guide alignment. Distance between production hoist and deflection sheave designed to increase rope life.</li> <li>3. Construction plan to focus on civil works, building foundation, concrete and structural steel to ensure the building is enclosed to facilitate mechanical, piping, electrical and instrumentation installation during the winter months.</li> </ol>
<p><b>Process Plant</b></p>	<ol style="list-style-type: none"> <li>1. Sizing of the grinding mills rely on grinding indices measurements typically used for rod-ball mill circuits, whereas this plant includes a SAG mill. Total grinding power may be incorrect.</li> </ol>	<ol style="list-style-type: none"> <li>1. The strong inverse correlation of all grinding indices against sulphur content allowed for a reduction of the uncertainty otherwise related with variable outcomes per rock types and with the selection of a design ore as a percentile of a population of measured indices. Comparison of the sizing calculation outcome from various methodologies, and involvement of an external third-party, allowed for the sizing to be confirmed.  The large SAG mill requested by the client and installation of larger-than-required power base for this mill, to have common electrical spares with ball mill, would allow for an increase of total grinding power draw above design level.</li> </ol>

Area	Risk and Potential Impact	Mitigation Approach
	<p>2. The Large HIG mills proposed have not been operated under abrasive ore duty. More frequent maintenance requirement foreseen on smaller units currently in operation calls for changes to mill design.</p>	<p>2. Work with the HIG mill supplier to include some improvements currently being tested on smaller units. Floor space has been reserved in the process plant in the event that an additional standby unit is required.</p>
<p><b>Underground High Density Sludge (HDS), Slurry Tailings and Paste Backfill Disposal</b></p>	<p><b>Remote plugs:</b></p> <p>1. The purpose of building the remote plugs is to isolate the Quemont, Horne and Horne 5 mines from the flooded former mines (Donalda, Joliet and Chadbourne). The construction of these plugs will be a challenge as they will be built remotely and as they need to be watertight for safe access to connected levels.</p> <p>2. One of the challenges with designing and building these plugs will be to hit the drifts with the required drill holes from surface.</p> <p><b>Tailings and HDS Management:</b></p> <p>3. The proposed plan to manage the tailings in the former mines during the two years of operation requires the filling of the bottom part of the Horne mine with cemented paste backfill before being able to discharge slurry tailings in the upper part. During the period of time required to paste backfill the bottom of the Horne mine, it will be necessary for the process plant and the paste plant to be operational to produce paste at its design throughput. It is important to note that the paste</p>	<p><b>Remote plugs:</b></p> <p>1. A conservative design using an adequate factor of safety and detailed planning of the construction including an access procedure with remote monitoring will be required. If the remote monitoring indicates leakage through or around the plugs (acceptable flowrate to be defined in further design stage), the drifts going to the plugs will require rehabilitation in order to grout them. If there is a need to grout one or both plugs it will be necessary to dewater both Chadbourne and Joliet mines below the interconnecting levels to allow safe access to the areas during the drift rehabilitation and grouting period.</p> <p>2. For locations where a drone survey cannot be performed, budget was added for the use of in borehole geophysical methods to help locate the targeted drifts. Crosshole tomography between two holes can provide the general location of the void in the horizontal plane around the borehole. By triangulating the results of crosshole tomography from three holes it is possible to pinpoint azimuth and approximate distance of the voids with respect to the hole.</p> <p><b>Tailings and HDS Management:</b></p> <p>3. Scheduling of tasks during the detailed engineering phase is critical, as well as close follow-up of the tasks during the pre-development period for ensuring the drifts and the old mine workings in the Horne mine are ready to receive slurry tailings and paste backfill when the production begins, along with ensuring the paste plant is commissioned.</p>



Area	Risk and Potential Impact	Mitigation Approach
	<p>plant needs to be fully operational and commissioned, producing a quality paste backfill product.</p> <p>4. During the first years of operation, tailings will be backfilled underground continuously when the process plant is in operation, either as slurry or cemented paste. One slurry line will be continuously used, and the other four (two slurry backfill lines and two paste backfill lines) will be alternatively used. For slurry backfill, numerous route pipe changes, start and stop of pumps and line flushes will occur over a short period of time.</p> <p>5. Considering possible volume inaccuracies in the digitized former mines and as Donalda and Horne cannot be surveyed before starting to discharge sludge or slurry tailings, it is possible the underground void volumes identified cannot be accessed. Consequence would be stop operations and build a surface management facility earlier than planned.</p> <p>6. Considering possible inaccuracies in the digitized drift, the estimated void volume network and their interconnections, it is difficult to develop an accurate layout of the boreholes for the Donalda, Quemont and Horne mines. As a survey cannot be performed for Donalda and Horne, the planned borehole may miss the target (unknown frequency).</p> <p>7. When filling voids with slurry backfill or sludge, slurry will not be classified, i.e., deslimed. Considering the rate at which the solids will settle and that dewatering will play an important role in this process, not only can the voids be filled quickly, but also it is the ability to tight fill the voids to maximize the amount of material returned underground. During the filling of the mines, the slurry velocity in the voids will prevent the material from settling. The sand filter and drain will contain the tailings and allow water to escape, however, because the slurry are unclassified, the dewatering rate will be controlled</p>	<p>4. For slurry and paste disposal, monitoring equipment is budgeted. Nevertheless, good communication between the underground mine and the process plant will be required and work procedures that will include emergency situations need to be developed and implemented.</p> <p>5. For the areas like Quemont that will be dewatered, drone surveys need to be completed prior to drilling. For this reason, the drone survey of the drifts and openings in Quemont should be initiated as soon as it is safe to do so considering the amount of time it will be required to analyze the data for the slurry backfilling plan development.</p> <p>6. For locations where a drone survey cannot be performed, budget was added for the use of in borehole geophysical methods (tomography and sonar) to help locate the targeted drifts and estimate the available/remaining volumes before and during the filling. Crosshole tomography between two holes can provide the general location of the void in the horizontal plane around the borehole. By triangulating the results of crosshole tomography from three holes it is possible to pinpoint azimuth and approximate distance of the voids with respect to the hole.</p> <p>7. Prior to the detailed engineering, it will be necessary to improve the understanding of the HDS and tailings vs. water behaviour by performing tests that, in turn, will be used to complete the design of the barricade water evacuation system and further develop the HDS and tailings slurry backfill procedures. It will also be required to test the crosshole tomography approach and set procedures for the detection of the former voids and drifts.</p>

Area	Risk and Potential Impact	Mitigation Approach
	<p>by the hydraulic conductivity of the slurries. When slurry is observed to be coming up the breather hole filling on that level, the backfilling will need to stop. Therefore, several passes will be required to fill the various levels with time allowed between filling events for the slurry to settle and the water to decant. This adds to the uncertainty related to the effective capability to backfill the voids and develop a schedule for the backfilling.</p> <p>8. Self-heating is expected to occur during operations, indications of such oxidation phenomenon with the backfill used in Horne are reported in Hall (1937). The majority of the backfill used to fill empty stopes at both the Quemont and Horne mines during their operation was similar. Concentrator tailings slurry, high in pyrrhotite, was mixed with slag and waste rock. Oxidation of the pyrrhotite cemented these blends sufficiently to allow pillar recovery with little dilution. While the backfill blends used at both former mines where developed to be porous enough to allow free drainage and air circulation, it is not certain that all of the fill placed underground was completely oxidized. As the mines are dewatered, there is the possibility that any remaining non-oxidized tailings could now become exposed to air. If self-heating does occur, the addition of the PCT, high in sulfides, placed as uncemented slurry, could further fuel the self-heating oxidation process. The result could be higher SO<sub>2</sub> generation possibly requiring extra ventilation or creating a zone of oxygen depletion in areas with low air flow. It could possibly also increase the acidity levels of the decant water as the voids of the Horne mine are filled with slurry tailings increasing the water treatment requirements. Similar self-heating phenomenon can occur from the cemented paste backfill (e.g., Bernier and Li, 2003).</p>	<p>8. Before the detailed engineering, it will be necessary to improve the understanding about the self-heating potential of materials to be used as backfill by performing tests. This material characterization test program will be used to confirm the design of the ventilation system and develop backfill procedures.</p>

Area	Risk and Potential Impact	Mitigation Approach
	<p>9. During the preproduction period the HDS will be returned underground on a continuous basis either in Donalda or Quemont mine. Depending on the mine dewatering rate and the volume of sludge produced one or more lines will be required.</p>	<p>9. For detailed design, vendor thickening and filtering tests should be performed on the tailings process. For detailed design, flow loop tests on the different tailings streams and consistencies should be performed to refine the friction losses for paste backfill and slurry tailings distribution. Good communication between those responsible for dewatering the mine, operating the water treatment plant and directing the sludge underground will be required including procedures to handle emergency situations. For the HDS, representative samples should be assessed for their rheological and settling properties.</p>
<p><b>Paste Backfill Plant</b></p>	<p>1. Paste rheology is not suitable for gravity distribution. Need to install a paste pump. 2. As paste plant is a part of process plant, general arrangement modifications are limited. 3. Solid deposition in the filtrate tank during plant stoppages.</p>	<p>1. Space has been kept under each paste hopper to install a paste pump. 2. Coordination and efficient communication will be necessary between the leaders of each discipline. Selection of equipment considering footprint. 3. Add an agitator to the tank. Sufficient height is already allowed in the general arrangement.</p>
<p><b>Infrastructure</b></p>	<p>1. So far, there is no agreement between Falco and the pipeline owner concerning the tie-in on the pipeline from Dufault Lake for fire water.</p>	<p>1. If an agreement is not reachable, a reservoir could be installed and hook-up to the city potable water supply network prior to the pump house.</p>

Area	Risk and Potential Impact	Mitigation Approach
<p><b>Water Treatment</b></p>	<p>1. Water Quality Predictions: The uncertainty of the quality of water in the mine pool, particularly in deeper levels, may have a significant impact on the SGR and consumable quantity (lime) during the preproduction dewatering phase. A series of 40 samples, in the Quemont No. 2 shaft, were collected at depths ranging from 30 m to 400 m below the ground surface, and a series of 6 samples were taken in Horne No. 4 shaft at 100 m, 200 m, 300 m, 400 m, 500 m and 600 m. Horne mine pool is expected to be dewatered down to 687 m. The Horne mine pool represents 74 % of the mine pool volume to be treated. All samples were characterized for major constituents (anions and cations). The peak SGR and lime consumption estimates for the Horne mine were based on the highest strength sample, which may not necessarily be representative of the water quality at levels deeper than 600 m.</p> <p>2. Sludge generation rate (SGR): The volume of the sludge produced during the preproduction period is substantial. Using the HDS process, the anticipated sludge production is up to 324,000 dry tonnes, or between 540,000 and 740,500 m<sup>3</sup>, based on an assumed sludge density of between 45% and 35%. The uncertainty of the SGR, particularly for the Horne mine pool, may have a significant impact on the total sludge volume to be handled on site and on the clarifier/thickener sizing. For Quemont water, representing 22% of the mine pool volume, the SGR is based on laboratory work conducted on recent samples taken from the pool. For the Horne/REMNOR mine pool, representing 74 % of the mine pool, SGR estimates are based on the chemical assays combined with a chemical precipitation model, and not on laboratory treatability tests. The uncertainty in the estimates for the volume of the areas of the mines to be backfilled by sludge results in uncertainty in the backfilling strategy.</p>	<p>1. Water Quality Predictions: Additional sampling in the Horne mine pool, particularly at deeper levels is required to reduce the risk associated with the water quality predications.</p> <p>2. Sludge generation rate (SGR): By optimising the HDS plant, including process changes and using a deep cone thickener, the sludge may be densified to increase the solid content to 45% or higher to reduce the sludge volume. Sludge dewatering could be expected to further reduce the volume by 20-40%, subject to pumpability. A sensitivity analysis for sludge density and backfill volume illustrates: a. Assuming a 35% sludge solids backfill density (dwb), then an increase of more than 11% of the average SGR the sludge volume would exceed the estimated backfill reservoir volume b. Assuming 45% sludge solids backfill density (dwb), then an increase of more than 63% of the average SGR the sludge volume would exceed the estimated backfill reservoir volume</p>

Area	Risk and Potential Impact	Mitigation Approach
	<p>3. Water Treatment Design:                      The uncertainty in the feed design basis, due to uncertainty in the:</p> <ul style="list-style-type: none"> <li>a. Concentration of selected feed constituents, namely Thiosalts, Nitrogen, and sulfate and/or</li> <li>b. Schedule of the dewatering of the deep portion of the mine pool, having the highest concentrations of these constituents, leads to uncertainty in the design and potential requirement for auxiliary treatment.</li> </ul> <p>The mine water treatment equipment are not sized to treat the peak load corresponding to the highest concentrations of constituents, rather, equipment are sized under a blending scenario of deep and upper mine waters. As a result, the water treatment equipment may not be sufficiently sized to treat the worst case scenario, and this would have implications to the dewatering schedule.</p> <p>Water from the deep Horne was not available for treatability testing but will be available for pilot testing.</p> <p>In the context of ammonia treatment, if either: a) the regulator applies site specific regulations to the project or b) nitrogen levels in the mine pool are found to be higher than the previous samples, then additional retention ponds and/or treatment may be required for discharge.</p>	<p>3. Water Treatment Design:                      Treatability tests were conducted on water from the Quemont mine pool to demonstrate successful treatment to meet regulatory requirements. These tests demonstrated the production of effluent that is not acutely toxic to aquatic life under approved testing conditions.</p> <p>Treatability tests will be conducted on the REMNOR deep mine water. A blending plan to mix waters from the deep mine and the upper mine will mitigate the uncertainty in the feed design basis (refer to Golder Report GAL037-1774165-5200-Lime Sludge Management Rev C). The benefits of the plan are as follows:</p> <ul style="list-style-type: none"> <li>a. Reduction in capital cost of the water treatment process (compared to the peak load design);</li> <li>b. Improvement in performance, including sludge characteristics, of the water treatment process;</li> <li>c. Improvement in the management of ammonia, which is believed to be present only in the deep Horne pool;</li> <li>d. Improvement in the management of thiosalts, which is believed to be in greater concentration in the deep water (if present);</li> <li>e. Reduction in the capital cost and operational complexity of the sludge backfill system.</li> </ul> <p>Thiosalts: The selected treatment process is assumed not to require a specific thiosalts oxidation polishing step. The feasibility study design, calling for a 70 minute retention time in the aerated reactor, and additional retention time in the clarifier, is expected to be sufficient to remove potential thiosalt toxicity, based on the laboratory tests conducted on Quemont water. Pilot tests on Horne No. 4 shaft (REMNOR) water are planned to refine the thiosalts handling.</p> <p>Nitrogen: Based on a review of feed nitrogen levels (ammonium) from several samples, and a review of effluent regulations for nitrogen, then final pH adjustment step is assumed to be effective to reduce the toxicity of ammonia,</p>

Area	Risk and Potential Impact	Mitigation Approach
	<p>4. Relocation of the existing HDS plant at the surface TMF site (during production with TMF): The existing HDS treatment plant will be relied upon for ongoing treatment through preproduction and production without TMF (year 1 and 2). However, the current location of the HDS plant will be inundated by tailings during the second production period (year 3 and beyond). Relocation is assumed to take place during down time in the summer months, and sufficient temporary storage is assumed to be available in existing structures at the Surface TMF site to accommodate the relocation period.</p> <p>5. Production Period; mine water pH Adjustment: During the production period, mine water will be transferred to a simple pH adjustment system, and fed to the Falco process plant. This process produces a lower density sludge and effluent that is supersaturated with respect to gypsum. As such, this effluent carries risks of gypsum scaling in downstream processes, particularly when it is fed high strength mine water. This water may have potential impacts to the metallurgy and piping maintenance. Similarly, the lower density sludge is difficult to filter, and when mixed with the process it may reduce the productivity of the plate and frame filter presses that are planned for the paste structural backfill system. Finally, the volume of the low density sludge may be significant compared to the backfill volume, for the period of production without the TMF.</p>	<p>and meet regulatory requirements. Therefore, so no auxiliary treatment will be required. Additional information about the management of nitrogen in the mine pool is provided in provided in a separate study (GAL038-1774165-5200_Ammonia_Assesment_Rev0).</p> <p>4. Relocation of the existing HDS plant at the surface TMF site (during production with TMF): Capital allowance has been provided for the plant to be relocated or replaced. Further work is required to define the location of the HDS plant during the second production period and the relocation/replacement schedule.</p> <p>5. Production Period, mine water pH Adjustment: The supersaturation, scaling effect and the risk associated with sludge low density can be reduced by modifying the process and allowing recirculation of sludge, or by effecting treatment in the presence of solids. Existing tailings handling equipment could be utilized for the purpose of densifying the production minewater sludge.</p>

Area	Risk and Potential Impact	Mitigation Approach
<b>Surface Water Management</b>	<ol style="list-style-type: none"> <li>1. Water diversions are required around the TMF. One of the diversions is large (Lake Vauze) and is only built at the closure. During operation water will be managed by pumping. Water level could raise and the lake could flood the toe of the TMF and cause excessive erosion.</li> <li>2. Dike failure could lead to tailings flow into the environment, eventually reaching Lac Dufault.</li> <li>3. If underground aquifer recharge capacity and tailings bleed water recovery are overestimated, more make-up water will be required.</li> </ol>	<ol style="list-style-type: none"> <li>1. Adequate design of pumping system is required. Earth works are to be done if erosion occurs. Dike design should account for critical situations causing loss of control lake water level.</li> <li>2. Assessing the consequences of a catastrophic event, such as dike failure and reviewing the established dike classification to confirm dike design criteria. Dike breach analyses is required to assess the consequences and to develop adequate mitigation measures.</li> <li>3. More water from TMF will be recycled, but eventually a fresh water intake source might be needed and needs to be identified.</li> </ol>
<b>Tailings and Reclaim Water Pipelines</b>	<ol style="list-style-type: none"> <li>1. Tailings properties show variability between rheological testing. The tailings samples should be further tested to obtain a better understanding of their rheological behavior.</li> <li>2. The pipeline rights-of-way should be secured early on in the project.</li> <li>3. Constructability issues in right-of-way. A narrow right-of-way or improper soil conditions could impact pipeline construction costs.</li> </ol>	<ol style="list-style-type: none"> <li>1. The pipeline design considers the use of piston diaphragm pumps for both tailings streams which can provide sufficient head for the entire range of rheological properties measured.</li> <li>2. The routing can be modified to avoid difficulties in acquiring land.</li> <li>3. Investigate the right-of-way for soil conditions and start acquiring the land for the pipeline right-of-way.</li> </ol>
<b>Surface Tailings Management Facility</b>	<ol style="list-style-type: none"> <li>1. An overestimation of available underground volume for tailings storage (aside from paste backfill) would require a larger capacity surface TMF and will require building it sooner.</li> <li>2. TMF design is based on tailings geotechnical characteristics from experience and literature not from testing of PCT and PFT. Actual geotechnical information and testing might require additional stability features, particularly with regards to liquefaction.</li> <li>3. TMF will require large construction quantities of different materials (such as gravel, sand, rock, etc.). Borrow sources are to be identified with respect to cost and impact.</li> </ol>	<ol style="list-style-type: none"> <li>1. Use historical data to produce a more in-depth and accurate evaluation of mine openings and backfilling. Establish a plan to investigate and quantify the locations and volumes of the available voids.</li> <li>2. Additional characterization of the various tailings streams is required to determine settling and geotechnical characteristics.</li> <li>3. Appropriate borrow search and material characterisation will refine the cost.</li> </ol>



Area	Risk and Potential Impact	Mitigation Approach
	<ol style="list-style-type: none"> <li>4. Proposed TMF overtakes old tailings ponds as well as water ponds that have been impacted by mining activities in the past but are well-known to be back to close to natural state.</li> <li>5. Increasing the mine life will have direct impact on surface TMF capacity and will require a review of its expansion potential through overtaking existing valleys and lakes.</li> <li>6. Detailed geotechnical and geophysical investigation might reveal foundation features that put the groundwater protection at risk.</li> <li>7. PCT and waste rock are potentially acid generating, and are highly reactive with elevated sulphur content. If not managed, they would be long term source of acid rock drainage that would require long-term water quality control.</li> </ol>	<ol style="list-style-type: none"> <li>4. Long term geochemical testing will allow understanding potential storage and closure problems and how to mitigate them.</li> <li>5. Identify the most promising capacity increase scenario (beyond current capacity) for the TMF.</li> <li>6. Foundation evaluation is required for detailed design of TMF and ground water protection evaluation.</li> <li>7. PCT and waste rock should be submerged quickly in the TMF to limit the development of acid rock drainage.</li> </ol>
<p><b>Environment and Permitting</b></p>	<ol style="list-style-type: none"> <li>1. Permitting schedule including a federal and provincial environmental and social impact study.</li> <li>2. Quemont site located partially on a historic TMF facility could represent a concern for restoration.</li> </ol>	<ol style="list-style-type: none"> <li>1. Provide documents to the environmental authorities that will answer both federal and provincial standards to avoid doubling the documentation provided.</li> <li>2. Initiate discussions with the current owner of the environmental liability of the site, the MERN and MDDELCC.</li> </ol>

Area	Risk and Potential Impact	Mitigation Approach
<p>Land Tenure and Third Party Rights</p>	<p>1. <i>In order to proceed with the activities described in this Report, Falco must obtain, in a timely manner, third party approvals, licenses, rights of way and surface rights (as described above in Chapters 16, 18 and 20); there can be no assurance that any such license, rights of way or surface rights will be granted, or if granted will be on terms acceptable to Falco and in a timely manner.</i></p> <p><i>Failure by Falco to obtain such third party approvals, licenses, rights of way and surface rights in a timely manner and on terms acceptable to it could have a negative impact on the development and construction of the Horne 5 Project and on the cost related thereto.</i></p> <p><i>Furthermore, Falco notes that the timeline of activities described in this Report, and the estimated timing proposed for commencement and completion of such activities, is subject at all times to matters that are not within the exclusive control of Falco. These factors include the ability to obtain, and to obtain on terms acceptable to Falco, financing, governmental and other third party approvals, licenses, rights of way and surface rights (as described above). Failure by Falco to obtain in a timely manner and on terms acceptable to Falco, financing, governmental and other third party approvals, licenses, rights of way and surface rights could have a negative impact on the development and construction of the Horne 5 Project and on the cost related thereto.</i></p>	<p>1. <i>Prepare an extensive list of activities describing the access right, infrastructure and modifications that will be required to continue to develop and proceed with construction of the Horne 5 Project; submit this list as soon as possible to the relevant third parties in order to initiate the negotiation that should lead to either the acquisition of such rights or to the grants of the required license and rights of way.</i></p> <p><i>As part of such negotiation, Falco shall seek appropriate financial support to provide such third party with adequate indemnity as may be required.</i></p> <p><i>Falco can begin work that does not require third party approval in order to keep with its timeline for the Project.</i></p>

Table 25-10: Project opportunities

Area	Opportunity Explanation	Benefit
<p><b>Geology and Mineral Resources</b></p>	<ol style="list-style-type: none"> <li>1. Higher local grades could improve metal content and recovery.</li> <li>2. Exploration potential for discoveries at depth and around the Horne 5 deposit by drilling.</li> <li>3. Further definition drilling may convert some of the existing Inferred mineral resources to Indicated or Measured category.</li> <li>4. Metal grades could be higher than expected. As shown in section 12.8, zinc assays from confirmation drilling programs returned a positive average difference of 49% compared to assays from Historical drill holes.</li> <li>5. It may be possible to locate the missing historical data from silver bulk sampling programs. These missing data had been found in 2016.</li> <li>6. The potential is high for new gold discoveries on Falco's properties around the Horne 5 deposit because historical exploration work in these areas did not focus on gold.</li> </ol>	<ol style="list-style-type: none"> <li>1. Higher project revenues due to better grades and recoveries.</li> <li>2. Potential to increase resources by drilling.</li> <li>3. Improve confidence in resource estimates and benefit for future higher level technical studies.</li> <li>4. Potentially more mineral resources.</li> <li>5. Additional silver resources could be added to the project improving economics.</li> <li>6. More mineral resources.</li> </ol>
<p><b>Underground Mining</b></p>	<ol style="list-style-type: none"> <li>1. Improved utilization rates for equipment and reduction in manpower and maintenance costs.</li> <li>2. Optimize the development and mining sequence to account for all constraints by modeling the mining and development sequence.</li> <li>3. Further detailed mine planning work.</li> <li>4. Optimizing location of infrastructures.</li> <li>5. Loading stations design may be modified to use high-speed conveyor to feed the skips instead of measuring boxes.</li> <li>6. Use electrical or battery-operated mining equipment such as bolter, scissor lift, scoop and trucks.</li> </ol>	<ol style="list-style-type: none"> <li>1. Improve mine performance and lower costs.</li> <li>2. Ability to execute multiple runs to obtain optimal scenario and delay CAPEX.</li> <li>3. Could possibly bring more ore into the mine plan.</li> <li>4. Potential reduction of the CAPEX.</li> <li>5. Reducing the shaft depth could reduce shaft rehabilitation duration and improve the schedule.</li> <li>6. Reduce ventilation requirements and heat sources.</li> </ol>

Area	Opportunity Explanation	Benefit
<p><b>Metallurgy and Process Plant</b></p>	<ol style="list-style-type: none"> <li>1. Reception of MIBC and hydrochloric acid in tanker trucks instead of 1 m<sup>3</sup> tote bins.</li> <li>2. The leach-CIP circuits could be replaced by CIL circuits. A trade-off study would be required to assess the differential CAPEX, OPEX and metal recoveries.</li> <li>3. A closed-loop heat recovery system harnessing the heat released by the cooling systems of major equipment and from process water has the potential of replacing a natural gas-based air heating system for the plant building.</li> <li>4. The February 2017 version of the mine plan was used to derive sulphur grade distribution statistics. Following various iterations, the final mine plan version is showing a higher average sulphur content (18.5% vs. 16.5%) than the February version. This would likely indicate that the 20<sup>th</sup> percentile of the sulphur distribution would show a higher value than the 10 %S used for sizing of the grinding mills.</li> </ol>	<ol style="list-style-type: none"> <li>1. The purchase prices of these reagents, FOB mine site, are lower when tanker trucks are considered, reducing the annual OPEX to the point of providing a fast payback for the additional CAPEX required for the holding and distribution tanks not included in the current expenditures</li> <li>2. Conversion to CIL circuits would remove the need for the CIP circuits, housed within the plant building envelope. CIL would require some modifications above the current leach tanks to accommodate for maintenance access of the submerged screens needed and somewhat lower carbon loading might require a resizing of the carbon stripping and regeneration circuits for larger circuits.</li> <li>3. Elimination of \$1.2M/a in natural gas consumption against minimal pumping power and maintenance requirements.</li> <li>4. With a higher design sulphur content, the resulting grinding mills required may be somewhat smaller than those specified earlier in the Project. Some capital cost reduction may result from such revision and from a somewhat smaller pyrite tails leach, CIP and CND circuits arising from a higher 20<sup>th</sup> percentile for sulphur distribution. The 80<sup>th</sup> percentile, used to size the circuits related to the processing of the pyrite concentrate may in turn be somewhat higher than the 23 %S value derived earlier and call for some additional capital outlays.</li> </ol>
<p><b>Paste backfill</b></p>	<ol style="list-style-type: none"> <li>1. Replace the two planned filter feed tanks by one tank.</li> <li>2. Optimize the operating sequence of the filter presses.</li> </ol>	<ol style="list-style-type: none"> <li>1. Potential reduction of the CAPEX</li> <li>2. Minimizing the size of auxiliary equipment like the air compressor, process water tank, filtrate tank, filter feed tank. Laboratory tests are required to confirm the binder consumption. Potential to reduce OPEX.</li> </ol>

Area	Opportunity Explanation	Benefit
Infrastructure	1. No major opportunities identified.	1. No major opportunities identified.
Water Treatment	<p>1. Alternative Alkali Reagents: The alkali source for the mine pool dewatering phase and the production without TMF (first 2 years) is a significant operating cost, therefore the selected treatment process has been designed as a multi-stage neutralization process, in part to offer the opportunity of cost savings by using alternative and lower cost reagents. The selected treatment process for preproduction offers an initial stage of neutralization, at a moderate pH, which may make use of alternative alkali, followed by a secondary stages that utilizes conventional alkali at an elevated pH. The selected treatment during production is a single stage pH adjustment, at neutral pH.</p>	<p>1. Alternative Alkali Reagents: The potential savings of an alternative alkali source are not included in the operating cost estimates, pending additional characterization and testing of alternative alkali reagents.</p> <p>The following alkali sources have been considered:</p> <ul style="list-style-type: none"> <li>▪ Lime Kiln Dust – Lime kiln dust may be obtained as a by-product of quicklime manufacture at a discount of up to 80% compared to quicklime. Lime kiln dust contains higher levels of calcium carbonate (incomplete calcining process) and impurities such as soot. Similarly, lime hydrator rejects contain neutralizing potential at a reduced cost. These materials tend to be stock-piled by manufacturers, since they have a relatively limited commercial demand, but availability in sufficient quantities has not been confirmed. The characteristics of these materials, such as reactivity, chemical composition, and moisture are inherently variable. Budgetary estimates obtained from two local supplier for by-product lime ranges between 7 \$/t to 25 \$/t (delivery charges not included), depending on the product compared to the budgetary quicklime cost of 150-200 \$/t. These products represent an important opportunity to reduce the price per alkali unit needed for ARD remediation, but the use of these products is subject to further work.</li> <li>▪ Quarry Limestone – Limestone is an effective and relatively inexpensive reagent that can be used only in the first stage of neutralization, up to a pH of 5-6. Limestone has approximately half the neutralizing potential per tonne compared to quicklime. Budgetary delivered prices obtained from local limestone quarries, approximately 130 km from the site, were between 30 \$/t to 35 \$/t for blasted and crushed limestone to approximately 55 \$/t for pulverized limestone,</li> </ul>

Area	Opportunity Explanation	Benefit
	<p>2. Rail transportation of quicklime: For bulk train deliveries, materials may be delivered and stored at the primary site, and subsequently shuttled by truck to the water treatment facility as required. Due to the large quantity of lime product required during the dewatering period, further work is recommended to assess the feasibility of train transport, or combined train and truck transport in order to assess this opportunity.</p> <p>3. Beneficial Use of HDS Sludge: HDS sludge will be disposed of in underground workings, however, a portion may be utilized for beneficial purposes. HDS sludge offers moisture retaining capacity, and as such can be used as an oxygen barrier as part of a cover system for closure of waste dumps and/or tailings facilities. The sludge may be used at the Falco facilities, or at adjacent facilities to mitigate the impact and assist with the closure of historic mining sites.</p>	<p>representing a 70% reduction in cost per tonne, or approximately a 35% reduction in cost on an equivalent neutralizing basis compared to quicklime. However, the limestone reaction may require additional retention time, and thus bigger reactors, so the use of this product is subject to additional work.</p> <p>2. Rail transportation of quicklime: Truck shipments have been estimated at approximately 80 \$/t considering the trucking distance from the supplier to the Rouyn-Noranda area is between 500 km and 800 km depending if it is an Ontario or Québec quicklime supplier. It is anticipated that train transportation would be less costly for the distances.</p> <p>3. Beneficial Use of HDS Sludge: Reduced costs for HDS sludge management and intangible benefits for assisting with the closure of historic mining sites.</p>

Area	Opportunity Explanation	Benefit
<b>Surface Water Management</b>	<ol style="list-style-type: none"> <li>1. Explore the possibility to use Vauze Lake as an expansion potential.</li> </ol>	<ol style="list-style-type: none"> <li>1. Using Lake Vauze as tailings area avoids the need for major diversion and brings control on surface water inflows.</li> </ol>
<b>Tailings Management</b>	<ol style="list-style-type: none"> <li>1. Explore the possibility to use Vauze Lake as an expansion potential.</li> <li>2. Explore possibility to amend PFT and use them as cover material for a multi-layer or single-layer cover system.</li> </ol>	<ol style="list-style-type: none"> <li>1. Allows to completely confine the PCT and to lower the overall PFT cell height. Eliminates the need to build a second polishing pond.</li> <li>2. Improves beneficiation of tailings and provides room for lower closure costs.</li> </ol>
<b>Environment and Permitting</b>	<ol style="list-style-type: none"> <li>1. Use of water treatment sludge to restore former TMF or to stabilize underground openings in the surrounding of the Project.</li> <li>2. Reuse or modify surface infrastructures at Quemont site for other uses.</li> </ol>	<ol style="list-style-type: none"> <li>1. Improvement of the general environmental quality in Rouyn-Noranda.</li> <li>2. Lower mine closure cost.</li> </ol>
<b>Execution Plan</b>	<ol style="list-style-type: none"> <li>1. During the detailed phase, investigate applying the following concepts to the Project: <ul style="list-style-type: none"> <li>▪ Pre-assembly of leach tank bridges, structural steel, and pipe racks and piping;</li> <li>▪ Pre-welding of tanks and piping offsite;</li> <li>▪ Use of pre-cast foundations;</li> <li>▪ Use of pre-fabricated buildings for offices and non-industrial use facilities.</li> </ul> </li> </ol>	<ol style="list-style-type: none"> <li>1. Compression of construction schedule increasing overall construction efficiency and reduction in preproduction CAPEX.</li> </ol>



## 26. RECOMMENDATIONS

*Pursuant to an agreement between Falco and a Third Party, Falco owns rights to the minerals located below 200 metres from the surface of mining concession CM-156PTB, where the Horne 5 deposit is located. Under the agreement, ownership of the mining concession remains with the Third Party.*

*In order to access the Horne 5 Project, Falco must obtain one or more licenses from the Third Party, which may not be unreasonably withheld, but which may be subject to conditions that the Third Party may require in its sole discretion. These conditions may include the provision of a performance bond or other assurance to the Third Party and the indemnification of the Third Party by Falco. The agreement with the Third Party stipulates, among other things, that the license shall be subject to reasonable conditions which may include, among other things, that activities at Horne 5 will be subordinated to the current use of the surface lands and subject to priority, as established in such party's sole discretion, over such activities. Any license may provide for, among other things, access to and the right to use the infrastructure owned by the Third Party, including the Quemont No. 2 shaft (located on mining concession CM-243 held by such Third Party) and some specific underground infrastructure in the former Quemont and Horne mines.*

*While Falco believes that it should be able to timely obtain the licenses from the Third Party, there can be no assurance that any such license will be granted, or if granted will be on terms acceptable to Falco and in a timely manner.*

*Although Falco believes that it has taken reasonable measures to ensure proper title to its assets, there is no guarantee that title to any of assets will not be challenged or impugned.*

*Falco also notes that the timeline of activities described in the current chapter, and the estimated timing proposed for commencement and completion of such activities, is subject at all times to matters that are not within the exclusive control of Falco. These factors include the ability to obtain, and to obtain on terms acceptable to Falco, financing, governmental and other third party approvals, licenses, rights of way and surface rights (as described above in Chapters 16, 18 and 20).*

*The foregoing disclaimer hereby qualifies in its entirety the disclosure contained in this Chapter 26 of this Report.*

## 26.1 Summary

This NI 43-101 compliant technical report on Falco's Horne 5 Project was prepared by experienced and competent independent consultants using accepted engineering methodologies and standards. It provides a summary of the results and findings from each major area of investigation including exploration, geological modelling, mineral resource, plant feed estimations, mine design, metallurgy, process design, infrastructure, environmental management, tailings and water management, capital and operating costs and economic analysis. The level of investigation for each of these areas is considered to be consistent or surpassing with that normally expected with a feasibility study.

The mutual conclusion of the QPs is that the Horne 5 Project as summarized in this FS contains adequate detail and information to support the positive economic outcome shown. The results of this feasibility study indicate that the Horne 5 Project is technically feasible and has financial merit at the base case assumptions considered.

In summary, the QPs recommend that the Project proceed to the detailed engineering phase and that project execution activities commence at Falco's discretion. Critical activities that need to be initiated or completed to maintain the proposed execution schedule are as follows:

- Complete negotiations in a timely manner to obtain third party approvals, licenses, rights of way and surface rights required by the Project;
- Environmental work, community engagement and permitting should continue as needed to support Falco's development plans;
- A relocation program should be initiated for the buildings located on the Horne 5 Mining Complex site;
- The preproduction dewatering program of the historical mines surrounding the Horne 5 deposit, rehabilitation of the Quemont No. 2 shaft and crown pillar stability studies should be initiated;
- The EIA should be completed and submitted;
- The early works program should be initiated and detailed engineering completed for the headframe and hoist room;
- Secure project financing.

Key Activities that need to be completed in 2018, based on the previously noted recommendations, have been budgeted to cost approximately \$110 M. A breakdown of this budget is summarized in Table 26-1.

Table 26-1: Proposed activities

Activity	Cost (\$K)
Underground Mine - Begin Shaft Rehabilitation (shaft, stations and barricades)	29.9
Mine Surface Facilities - Hoist Room and Headframe (partial) Construction	32.5
Electrical and Communications - Permanent Electrical Line Preparation	2.5
Community Infrastructure and Relocation (remaining)	1.1
Tailings and Water Management - Preproduction Water Treatment Plant Construction and Pipelines	32.6
Associated Owner's Costs & Indirects	11.4
<b>Total</b>	<b>110 M</b>

## 26.2 Additional Recommendations

Analysis of the results and findings from each major area of investigation completed as part of this FS suggests numerous recommendations for further investigations to mitigate risks and/or improve the base case designs. The following sections summarize the key recommendations arising from this FS.

### 26.2.1 Geology

The lower portion of the Horne 5 deposit is less drilled (no systematic drilling fan pattern) than the upper and medium portions. Currently categorized as Inferred in the estimate, confidence in shape and continuity of mineralization remains to be improved. InnovExplo recommends realizing infill underground drilling programs targeting the lower portion of the deposit during the mine life. No cost estimation is proposed by InnovExplo for this recommendation due to the remoteness in time for its activation.

It is also recommended to perform infill underground drilling programs targeting the lower portion of the deposit during the mine life.

### 26.2.2 Rock Engineering

- Confirm assumptions and conditions once underground access is available. Reassess designs when required based on the actual conditions encountered;
- As part of the detailed engineering phase of work, the following should be done:
  - Detailed design of de-stressing options or alternative designs (for diabase dike and converging mining front);
  - Detailed ground support design of the garage and crusher;

- Detailed backfill strength design;
- The impact of the identified secondary faults on local stope stability and stope sequence assessed;
- Development of a Ground Control Management Plan (“GCMP”). This plan would be regularly updated and audited during the life of mine;
- Design of a micro-seismic monitoring system. The system should be designed such that tactical decisions can be made using the data (e.g., identification of seismic sources, highly stressed volumes of rock, de-stress volumes of rock, etc.) and re-entry protocols developed;
- For stope blast holes, procedures should be developed during detailed design and operation to deal with stuck drill rods or collapsed stope blast holes. Drilling directions may need to change such that the holes are drilled in the direction or closer to the direction of the major principal stress or a curtain of blast holes drilled to protect blasting patterns;
- Develop a ground support implementation program and a quality control and assurance program for ground support and paste backfill strength testing (e.g., using pull-tests and paste cylinders collected at stope pour points);
- Development of an instrumentation plan, which would include instruments such as SMART-cables and MPBXs in:
  - o Surface crown pillars identified as being at risk;
  - o Large infrastructure (e.g., crushers and garage);
  - o The pillar between the historic Horne mine and the new developments;
  - o The area of concern where the mining front are converging in Lower Phase 1 mining area;
  - o Drifts bounding sill pillars during sill recovery;
  - o Footwall drifts in ore;
  - o Instruments in Quemont No. 2 shaft;
  - o Instruments in areas of anticipated high stresses and thus stress damage.
- Once underground, the following should be done:
  - Re-assess ground support needs when the rock mass conditions and behaviour are confirmed. Change of conditions should be monitored for and ground support modified accordingly;
  - Confirm primary and secondary faults, due to difficulty in assessing character and rock bridges from current drill holes;
  - Development of a stope stability database based on the Mathews’ method (Golder 1981);

- Systematic geological and geotechnical mapping should be conducted. Mapping should start as soon as underground access is available. At a minimum feature type, orientation (dip and dip direction), and geological units should be systematically recorded. Fix infrastructure should be mapped in detail so that actual structural conditions are recorded within the excavation and the design checked;
- Stress measurements early during re-access to the mine (around 500 m depth), once Horne 5 area is accessible at 1,000 m depth, and at 1,300 m and 1,600 m depths thereafter. The need for stress measurements should also be assessed once underground access is made. Measurements may be needed at difference depths than specified or for different purposes such as sill pillar stress determination.

### 26.2.3 Underground Mining

- Since new technologies will be implemented, it will be important to train personnel to maximize the efficiency of the equipment;
- Benchmarking on automation technologies to ensure best possible integration and performances;
- Reassess voids calculations in historical mines from actual volumes once dewatering of these mines is underway;
- Switch to electrical equipment as much as possible to minimize ventilation requirements and heat sources;
- Proceed to detailed engineering for the material handling system to address uncertainties and ensure proper performances;
- Proceed to detailed engineering for underground electrical network, construction and mine pumping network.

### 26.2.4 Paste Backfill Testwork and Plant Design

Confirm the result of filtration tests in order to validate the filter press sizing. Filter press are high capital cost equipment and require multiple auxiliary services for their operation. The impact on paste plant CAPEX is significant.

### 26.2.5 Metallurgical Testwork

A trade-off study looking into the potential benefits of implementing CIL circuits, instead of leaching followed by CIP, is recommended.

### 26.2.6 Process Plant

If the possibility exists to consider co-deposition of the pyrite concentrate and flotation tailings in the TMF, a simplification of the plant flowsheet would result through the combination of the dedicated leach, CIP and cyanide destruction circuits into a single one dealing with both products.

No other recommendations unless the CIL approach is retained following completion of the trade-off study suggested in Section 26.2.5.

### 26.2.7 Market Studies and Contracts

With respect to the concentrate logistics, discussions with potential offtakers should take place between the Project go-ahead date and 1 year before plant start-up. These discussions will ensure smelter capacity is available at target destinations and terms are agreed upon. This will also aid to ensure that the appropriate logistics requirements are in place for start-up. Although from a geographic standpoint there are logical destinations for the two concentrate products, smelter capabilities may not be suitable for the quality (particularly in the case of the zinc). Other smelter alternatives will need to be fully evaluated. Negotiation of smelter/offtake contracts will require an update on logistics costs from the various service providers and, eventually, the negotiation of contracts with these service providers once the destinations are discerned.

Glencore Canada has rights of first refusal with respect to purchase or toll process all or any portion of the concentrates and other mineral products from the Horne 5 Project.

### 26.2.8 Tailings and Waste Rock Management

- Liquefiable soils may be present in other areas where dikes are planned to be built and the assessment of their liquefaction potential should be performed once a detailed geotechnical investigation is conducted;
- A detailed geotechnical investigation and geophysical surveys should be performed to identify the potential zones of soft clays in the area of the future TMF;
- The tailings and the waste rock will require a management strategy on surface meeting recommendations of Directive 019;
- The installation of appropriate instrumentation, such as piezometers, inclinometers and settlement plates, among others, for all dikes is recommended for soil and structural behaviour during and after construction. A detailed instrumentation plan should be put in place at the detailed design stage of the TMF.

The next stage investigation and testing program should contain, without being limited to, the following:

- Groundwater baseline and protection aspects: field work and sampling should be performed at the TMF site to define the baseline groundwater quality; studies and modelling must be performed in order to determine groundwater protection conditions at the PFT cell;
- Surface water baseline: more comprehensive analysis should be completed on the surface water quality at the TMF site;
- Tailings geotechnical and geochemical characterization: both PCT and PFT should undergo comprehensive geotechnical characterization, including laboratory testing and, potentially, flume deposition testing to better define strength parameters and deposition angles. All new metallurgical samples should also be submitted to geochemical testing;
- Dike design: detailed geotechnical investigation combined with a full geophysical coverage of the TMF area should be performed. The geotechnical investigation should include an extensive laboratory and in-situ testing program. Detailed design study, including stability analyses, foundation liquefaction potential assessment, detailed deposition planning and construction drawings, should be performed;
- Construction materials: a borrow search and/or a quarry development study should be undertaken to define available materials for the construction of the TMF infrastructure. Materials should be sampled and characterized both from geochemical and geotechnical points of view;
- Monitoring of geotechnical performance: a detailed instrumentation plan should be prepared in order to monitor the foundation behaviour during and after construction of dike, as well as dike performance during operation and at closure;
- Water management: a detailed water management plan should be put together including refined water balance and detailed design for water management infrastructure. Collection of site-specific climate data could be part of the preparation effort as well as generation of detailed topographical data;
- Emergency response plan: a dike breach analysis should be conducted for all retaining structures at the TMF and their classification should be reviewed. Consequences of failure will then be used to provide information for the emergency response plan of the TMF site.

### 26.2.9 Tailings and Reclaim Water Pipelines

- Further work is recommended to assess any constructability issues on the pipeline right-of-way including soil conditions and access;
- The pipeline right-of-way should be secured early on in the Project;
- It is recommended to install the pipeline below ground. Burying the pipeline will remove the need to thermally insulate the pipeline. The pipeline will also be protected against third-party damage.



### 26.2.10 Water Management and Treatment

- Additional water quality sampling and testing is recommended as new information becomes available and engineering designs, water management plans are finalized in order to update and refine the predictions for operational and closure water treatment needs.
- A cost benefit assessment should be undertaken during the detailed design stage of the Project's development;
- The climate and site condition projections should get reassessed periodically during the LOM. Such periodic assessments will help monitor the potential changes in climate and conditions (such as the duration of the LOM itself) that may affect the Project's infrastructure.

As necessary, the design of the Project's infrastructure should be reviewed following such assessments. For example, for the operation and closure phases:

- If future climate data indicate driest trend, an alternative source of makeup water for the process plant could be necessary, if a review of the water balance indicates a water deficit. In a future dry scenario, no impact is anticipated for the drainage structures, which were designed for extreme events;
- If future climate data indicate wettest trend, such as an increase in extreme precipitation events or snowmelt volumes, a review of the water treatment plant capacity could be necessary where a reviewed water balance reveals the necessity to manage excess water in the TMF. Also, a review of the design of the drainage structures (ditches and spillways) could be necessary according to the results of a reviewed climate frequency analysis, even if those structures were currently designed with a freeboard.

### 26.2.11 Water Quality

- Updated water quality modelling should be completed on the updated water balance for the mine and the TMF sites and as engineering designs, water management plans are finalized in order to update and refine the predictions for operational and closure water treatment needs;
- An evaluation of the anticipated properties of water treatment sludge should be completed in support of sludge management planning;
- Sludge management plans should be developed and incorporated into the mine site water balance and water quality model.

### 26.2.12 Mine Hydrogeology

- Pressure transducers should be put in place in the mine shafts at Horne, Quemont, Donalda, Chadbourne and Joliet prior to initiate the dewatering to monitor water levels fluctuations and confirm the hypothesis made on the hydraulic connections between the existing mines;
- The observation wells network should be expanded to assess groundwater flow conditions and groundwater quality in the surrounding area of the Horne/Quemont mines;
- Monitoring of water levels from the Osisko North basin and the Verglas Pit should be initiated prior to initiating the dewatering of the existing mines.

### 26.2.13 Slurry Tailing Distribution

- For detailed design, vendor thickening and filtering tests should be performed.

### 26.2.14 Environment and Permitting

In the next stages of the Project, it is recommended to undertake the following activities in the goal of better defining the environmental impacts:

- Continuation of the environmental baseline studies to cover the surface TMF site;
- Continuation and completion of the environmental impact assessment;
- Initiate public and First Nations consultations.

Furthermore, no dynamic testing has been performed on the tailings so far. However, for the purposes of this stability assessment, it was assumed that the tailings would liquefy under the design earthquake. Post-seismic analyses for dike PFT-1 were performed with the assumption that the entire tailings impoundment upstream of dike PFT-1 had liquefied. Therefore, a detailed geotechnical investigation and geophysical surveys should be performed to identify the potential zones of soft clays in the area of the future TMF. The preferred method of rehabilitation of the PFT cell is building a cover to limit either the infiltration, or the infiltration and the oxygen diffusion to the underlying tailings.

It is proposed that climate change should not be directly taken into account for water management structure operational designs: all Horne 5 drainage structures are designed for extreme events based on statistical analysis of historical climate data, which includes recent years, without accounting directly for climate change. It is recommended that:

- A cost benefit assessment be undertaken during the detailed design stage of the Project's development;
- The climate and site condition projections get reassessed periodically during the LOM. Such periodic assessments will help monitor the potential changes in climate and conditions (such as the duration of the LOM itself) that may affect the Project's infrastructure.

## 27. REFERENCES

### 27.1 Geology and Mineral Resources

- Ames, H. L., and Hrynewich W., 1963. Zone 5, D. D. Core Sample 73 – Preliminary Metallurgical Testing, Noranda Metallurgical Department.
- Ayer, J.A., Thurston, P.C., Bateman, R., Dubé, B., Gibson, H.L., Hamilton, M.A., Hathway, B., Hocker, S.M., Houlé, M.G., Hudak, G., Ispolatov, V.O., Lafrance, B., Leshner, C.M., MacDonald, P.J., Péloquin, A.S., Piercey, S.J., Reed, L.E., and Thompson, P.H., 2005. Overview of results from the greenstone architecture project: discover Abitibi initiative. Ont. Geol. Surv., Open File Report 6154, pp. 107.
- Ayer, J.A., Ketchum, J., and Trowell, N.F., 2002b, New geochronological and neodymium isotopic results from the Abitibi greenstone belt, with emphasis on the timing and the tectonic implications of Neoproterozoic sedimentation and volcanism: Ontario Geological Survey Open File Report 6100, pp. 5-1 to 5-16.
- Ayer, J., Amelin, Y., Corfu, F., Kamo, S., Ketchum, J.F., Kwok, K., and Trowell, N.F., 2002a, Evolution of the Abitibi greenstone belt based on U-Pb geochronology: Autochthonous volcanic construction followed by plutonism, regional deformation and sedimentation: Precambrian Research, v. 115, pp. 63–95.
- Ayer, J.A., Trowell, N.F., Amelin, Y., and Corfu, F., 1998, Geological compilation of the Abitibi greenstone belt: Toward a revised stratigraphy based on compilation and new geochronology results: Ontario Geological Survey Miscellaneous Paper 169, pp. 4-1 to 4-14.
- Bancroft, W.L., 1980, No. 5 Zone, Au, Ag and pyrite ore stopes and low grade bodies, production and reserves, Noranda Mines Ltd., Internal Report, revised March 31, 1980.
- Bancroft, W.L., 1979. Regarding 5 Zone silver. Summary of 5 Zone silver assays (1947-1963) from 76 bulk samples. Noranda Inc. Internal note. 7 pages.
- Bancroft, W.L., and Atkinson, I., 1987, Book 1A: Reproduction of a compilation of data over a period of fifty-four years, Geology, Horne division, Noranda Mines Ltd, Unpublished company report.
- Barrett, T.J., Cattalini, S., and MacLean, W.H., 1991, Massive sulfide deposits of the Noranda area, Québec. I. The Horne mine; Canadian Journal of Earth Sciences, v. 28, pp. 465-488.
- Barrett, T.J., and MacLean, W.H., 1991, Chemical, mass and oxygen isotope changes during extreme hydrothermal alteration of an Archean rhyolite, Noranda, Quebec: Economic Geology, v. 86, pp. 406-414.

- Barrie, C.T., and Hannington, M.D., 1999, Introduction: Classification of VMS deposits based on host rock composition, in Barrie, C.T., and Hannington, M.D., eds., *Volcanic-Associated Massive Sulfide Deposits: Processes and Examples in Modern and Ancient Settings: Reviews in Economic Geology*, v. 8, pp. 2-10.
- Bateman, R., Ayer, J.A., and Dubé, B., 2008, The Timmins-Porcupine gold camp, Ontario: Anatomy of an Archean greenstone belt and ontogeny of gold mineralizations. *Economic Geology*, v. 103, pp. 1285–1308.
- Benn, K., and Peschler, A.P., 2005, A detachment fold model for fault zones in the Late Archean Abitibi greenstone belt: *Tectonophysics*, v. 400, pp. 85–104.
- Benn, K., Miles, W., Ghassemi, M.R., Gillet, J., 1994. Crustal structure and kinematic framework of the north-western Pontiac Subprovince, Québec: an integrated structural and geophysical study. *Canadian Journal; of Earth Sciences*, Vol. 31, pp. 271-281.
- Brousseau, K., Verschelden, R., and Pelletier, C., 2014. Technical Report and Mineral Resource Estimate for the Horne 5 Deposit (compliant with National Instrument 43-101 and Form 43-101F1). Report prepared by InnovExplo Inc. for Falco Pacific Resource Group Inc., 135 pages.
- Calvert, A.J., and Ludden, J.N. 1999. Archean continental assembly in the southeastern Superior Province of Canada. *Tectonics*, Vol. 18, No. 3; pp. 412-429.
- Calvert, A.J., Sawyer, E.W., Davis, W.J., and Ludden, J.N., 1995. Archean subduction inferred from seismic images of a mantle suture in the Superior Province. *Nature*, v. 375, pp. 670-674.
- Cattalini, S., Barrett, T.J., MacLean, W.H., Hoy, L., Hubert, C., Fox, J.S., 1993, *Métallogenèse des gisements Horne et Quémont (région de Rouyn-Noranda)*, Service de la géoinformation DGEGM, éditeur F. Dompierre, Bibliothèque nationale du Québec, ET 90-07.
- Chown, E.H., Daigneault, R., Mueller, W., and Mortensen, J., 1992. Tectonic evolution of the Northern Volcanic Zone of Abitibi Belt. *Canadian Journal of Earth Sciences*, v. 29, pp. 2211-2225.
- Corfu, F., 1993. The evolution of the southern Abitibi greenstone belt in light of precise U–Pb geochronology. A special issue devoted to Abitibi ore deposits in a modern context. *Economic. Geology*. 88, pp. 1323–1340.

- Daigneault, R. and Pearson, V., 2006. Physical volcanology of the Blake River caldera complex: a new interpretation of an old structure; in *The Komatiite-komatiitic Basalt-basalt Association in Oceanic Plateaus and Calderas: Physical Volcanology and Textures of Subaqueous Archean Flow Fields in the Abitibi Greenstone Belt*, (ed.) W.U. Mueller, R. Daigneault, V. Pearson, M. Houle, J. Dostal, and P. Pilote, Geological Association of Canada-Mineralogical Association of Canada Joint Annual Meeting Montreal, Quebec, Field Trip A3, Guidebook, pp. 62-72.
- Daigneault, R., Mueller, W.U., Chown, E.H., 2004. Abitibi greenstone belt plate tectonics: the diachronous history of arc development, accretion and collision. In Eriksson, P.G., Altermann, W., Nelson, D.R., Mueller, W.U., Catuneanu, O. (Eds.). *The Precambrian Earth: Tempos and Events*, Series: *Developments in Precambrian geology*, Vol. 12, Elsevier, pp. 88–103.
- David, J., Dion, C., Goutier, J., Roy, P., Bandyayera, D., Legault, M., and Rheume, P., 2006. *Datations U-Pb effectuées dans la sous-province de l'Abitibi à la suite des travaux de 2004-2005*; Ministère des Ressources naturelles et de la Faune (Québec) (MRNF), Report RP 2006-04, 22 pages.
- de Kemp, E.A., Monecke, T., Sheshpari, M., Girard, E., Lauziere, K., Grunsky, E.C., Schetselaar, E.M., Goutier, J.E., Perron, G., and Bellefleur, G., 2011. 3D GIS as a support for mineral discovery. *Geochemistry: Exploration, Environment, Analysis*, v.11; pp. 117-128.
- Derome, C., 1982, *Evaluation de la propriété Osisko (bloc 11) et des travaux effectués*, Projet 80-811, Canton Rouyn, Exploration Aiguebelle Inc.-SOQUEM, GM-38548.
- de Rosen-Spence, A.F., 1976. *Stratigraphy, development, and petrogenesis of the Noranda volcanic pile*, Noranda, Quebec. Ph.D. Thesis. Univ. Toronto, Toronto, Ont., 116 pp.
- Dimroth, E, Imrech, L., Rocheleau, M., Goulet, N., 1983. Evolution of the south-central part of the Archean Abitibi Belt, Quebec. Part III: plutonic and metamorphic evolution and geotectonic model. *Canadian Journal of Earth Sciences*, Vol. 20, pp. 1374-1388.
- Dimroth, E, Imrech, L., Rocheleau, M., Goulet, N., 1982. Evolution of the south-central part of the Archean Abitibi Belt, Quebec. Part I: stratigraphy and paleostratigraphic model. *Canadian Journal of Earth Sciences*, Vol. 19, pp. 1729-1758.
- Dubé, B., Gosselin, P., Mercier-Langevin, P., Hannington, and Galley, A., 2007. Gold-rich Volcanogenic Massive Sulfide Deposits, in Goodfellow, W.D., ed., *Mineral deposits of Canada: A Synthesis of Major Deposit-Types, District Metallogeny, the Evolution of Geological Provinces, and Exploration Methods*: Geological Association of Canada, Mineral Deposit Division, special Publication No. 5, pp. 75-94.
- Falco Resources Ltd., *Technical Report and Updated Mineral Resource Estimate for the Horne 5 Deposit*, March 4, 2016.

- Fisher, D.F., 1974. A volcanic origin for the No. 5 Zone of the Horne mine, Noranda, Quebec; *Economic Geology and the Bulletin of the Society of Economic Geologists*, v. 69, pp. 1352-1353.
- Fisher, D.F., 1970. The origin of the Number Five Zone, Horne mine, Noranda, Quebec. M.Sc. thesis, University of Western Ontario, London, Ont.
- Franklin, J.M., Gibson, H.L., Jonasson, I.R., Galley, G., 2005, Volcanogenic Massive Sulfide Deposits, *Economic Geology 100th Anniversary Volume*, pp. 523-560.
- Gagné, M. R., and Masson, J., 2013. A Step Forward! An Act to Amend the Mining Act (2013 S.Q., c. 32). *Mining Bulletin*. Fasken Martineau. 7 pages.
- Galley, A.G., Hannington, M.D., and Jonasson, I.R., 2007, Volcanogenic massive sulphide deposits, in Goodfellow, W.D., ed., *Mineral Deposits of Canada: A Synthesis of Major Deposit-Types, District Metallogeny, the Evolution of Geological Provinces, and Exploration Methods: Geological Association of Canada, Mineral Deposits Division, Special Publication No. 5*, pp. 141-161.
- Gélinas, L., and Ludden, J.N., 1984. Rhyolitic volcanism and the geochemical evolution of an Archaean central ring complex: the Blake River Group volcanics of the southern Abitibi belt, Superior province. *Phys. Earth Planet. Inter.* 35, pp. 77–88.
- Gélinas, L., Trudel, P., and Hubert, C., 1984. Chemostratigraphic division of the Blake River Group, Rouyn-Noranda area, Abitibi, Quebec; *Canadian Journal of Earth Sciences*, v. 21, pp. 220-231.
- Gélinas, L., Brooks, C., Perrault, G., Carignan, J., Trudel, P., Grasso, F., 1977. Chemostratigraphic division within the Abitibi volcanic belt, Rouyn-Noranda district, Quebec. In: Baragar, W.R.A., Coleman, L.C., Hall, J.M. (Eds.), *Volcanic Regimes in Canada*, Geol. Ass. Can., Spec. Pap., Vol. 16, pp. 265–295.
- Gibson, H.L., and Galley, A.G., 2007. Volcanogenic Massive Sulphide Deposits of the Archean, Noranda District, Quebec. In, *Mineral Deposits of Canada: A synthesis of major deposit, types district metallogeny, the evolution of geological provinces and exploration methods*, Goodfellow, W.D. ed., *Special Publication 5, Mineral Deposits Division, Geological Association of Canada*, pp. 553-552.
- Gibson, H.L., Kerr, D.J., and Cattalini, S., 2000. The Horne mine: geology, history, influence on genetic models, and a comparison to the Kidd Creek Mine; *Exploration and Mining Geology*, v. 9, pp. 91-111.
- Gibson, H.L. and Watkinson, D.H., 1990. Volcanogenic massive sulphide deposits of the Noranda Cauldron and Shield Volcano, Quebec; in *The Northwestern Quebec Polymetallic Belt*, (ed.) M. Rive, P. Verpaelst, Y. Gagnon, J.M. Lulin, G. Riverin, and A. Simard; *The Canadian Institute of Mining and Metallurgy, Special Volume 43*, pp. 119-132.

- Gibson, H.L., 1990. The Mine Sequence of the Central Noranda Volcanic Complex: geology, alteration, massive sulphide deposits and volcanological reconstruction; Ph.D. thesis, Carleton University, Ottawa, Ontario, 715 pages.
- Gibson, H.L., 1989. The Mine Sequence of the Central Noranda Volcanic Complex: geology, alteration, massive sulphide deposits and volcanological reconstruction. Ph.D. Thesis. Carleton Univ., Ottawa, Ont., 715 pages.
- Gibson, H.L., Walker, S.D., and Coad, P.R., 1984. Surface geology and volcanogenic base metal massive sulphide deposits and gold deposits of Noranda and Timmins; Field Trip 14, Guidebook, Geological Association of Canada-Mineralogical Association of Canada Joint Annual Meeting, London, Ontario, 124 pages.
- Goldie, R., Kotila, B. and Seward, D., 1979, The Don Rouyn Mine: An Archean porphyry copper deposit near Noranda, Quebec, Economic Geology, Scientific Communications, vol. 7, no. 7, pp.1680-1684.
- Goldie, R., 1978. Magma mixing in the Flavrian pluton, Noranda area, Quebec; Canadian Journal of Earth Sciences, v. 15, pp. 132-144.
- Goodwin, A.M. 1977. Archean volcanism in Superior Province, Canadian shield. In: Baragar, W.R.A., Coleman, L.C., Hall, J.M. (Eds.), Volcanic Regimes in Canada, Geol. Ass. Can., Spec. Pap., vol. 16, pp. 205–241.
- Goutier, J., and Melançon, M., 2007, Compilation géologique de la Sous-province de l'Abitibi (version préliminaire): Ministère des Ressources naturelles et de la Faune du Québec.
- Goutier, J., 1997, Géologie de la région de Destor: Ministère des Ressources naturelles du Québec 37 pages. RG 96-13.
- Guzun, V., 2012. Mining Rights in the Province of Quebec. Blakes Bulletin Real Estate – Mining Tenures July 2012. Blake, Cassels & Graydon LLP. 7 pages.
- Hall, O., 1937, Mining at Noranda. Transactions of the Canadian Institute of Mining and Metallurgy, Vol. 40, pp. 141-164.
- Harquail, J.A., 1952a, Joliet-Quebec Mining Limited, Underground drilling program 1950-1951, GM 20600.
- Harquail, J.A., 1952b, Joliet-Quebec Mining Limited, Surface drilling program 1950-1951, GM 20601.
- Hodge, H.J., 1967. Horne mine; in CIMM Centennial Field Excursion Northwestern Quebec-Northern Ontario, (ed.) M.K. Abel; Canadian Institute of Mining and Metallurgy, Montreal, Quebec, pp. 40-45.



- Joly, W. T., 1978. Metamorphic history of the Archean Abitibi Belt. In *Metamorphism in the Canadian Shield*. Geological Survey of Canada, Paper 78-10, pp. 63-78.
- Jourdain, V., Runnels, D., and Pelletier, C., 2016. Technical Report and Updated Mineral Resource Estimate for the Horne 5 Deposit (compliant with National Instrument 43-101 and Form 43-101F1). Report prepared by InnovExplo Inc. for Falco Pacific Resource Group Inc. 176 pages.
- Kerr, D.J. and Gibson, H.L., 1993. A comparison of the Horne volcanogenic massive sulphide deposit and intracauldron deposits of the Mine Sequence, Noranda, Quebec; *Economic Geology and the Bulletin of the Society of Economic Geologists*, v. 88, pp. 1419-1442.
- Kerr, D.J., and Mason, R., 1990, A re-appraisal of the geology and ore deposits of the Horne mine complex at Rouyn-Noranda, Quebec: *Canadian Inst. Mining Metallurgy Spec.* Vol. 43, pp. 153-165.
- Lafrance, B., Davis, D.W., Goutier, J., Moorhead, J., Pilote, P., Mercier-Langevin, P., Dube, B., Galley, A.G., and Mueller, W.U., 2005. Nouvelles datations isotopiques dans la portion québécoise du Groupe de Blake River et des unités adjacentes; Ministère des Ressources naturelles et de la Faune (Québec), Report RP 2005-01, 15 pages.
- Laurin, J., 2010, Geology, Gold Mineralization and Alteration of the Horne West Property Rouyn-Noranda. M.Sc. thesis, University of Ottawa. 161 pages.
- Leshner, C.M., Goodwin, A.M., Campbell, I.H., and Gorton, M.P. 1986. Trace-element geochemistry of ore-associated and barren, felsic metavolcanic rocks in the Superior Province, Canada. *Canadian Journal of Earth Sciences*, 23: pp. 222-237.
- Lichtblau, A., and Dimroth, E., 1980. Stratigraphy and facies at the south margin of the Archean Noranda caldera, Noranda, Québec. *Current Research, Part A, Geological Survey of Canada, Paper 80-1A*, pp. 69–76.
- Lelièvre, J., 2014. Metallurgical Testwork on the Horne – Zone 5 Ore. Report prepared by Unité de recherche et de service en technologie minérale (URSTM). Internal Report. 29 pages.
- Ludden, J.N., Hubert, C., and Gariépy, C., 1986. The tectonic evolution of the Abitibi greenstone belt of Canada: *Geological Magazine*, v. 123, pp. 153-166.
- MacLean, W. H., and Hoy, L. D., 1991. Geochemistry of hydrothermally altered rocks at the Horne mine, Noranda, Quebec. *Economic Geology*, v. 86, pp.506-528.

- Mercier-Langevin, P., Goutier, J., Ross, P.-S., McNicoll, V., Monecke, T., Dion, C., Dubé, B., Thurston, P., Bécu, V., Gibson, H., Hannington, M., and Galley, A., 2011. The Blake River Group of the Abitibi greenstone belt and its unique VMS and gold-rich VMS endowment; Geological Survey of Canada, Open File 6869, 61 pages.
- Mercier-Langevin, P., Hannington, M.D., Dubé, B., Bécu, V., 2010, The gold content of volcanogenic massive sulfide deposits, *Miner Deposita* (2011) 46: pp. 509-539.
- MERQ-OGS, 1984, Lithostratigraphic map of the Abitibi subprovince: Ontario Geological Survey and Ministère de l'Énergie et des Ressources, Québec, Map 2484 and DV 83–16.
- Ministère de l'Énergie et des Ressources Naturelles (MERN), Direction de la restauration des sites miniers, « Guide de préparation du plan de réaménagement et de restauration des sites miniers au Québec », Novembre 2016.
- Monecke, T., Gibson, H., Dubé, B., Laurin, J., Hannington, M.D., and Martin, L., 2008. Geology and volcanic setting of the Horne deposit, Rouyn-Noranda, Quebec: initial results of a new research project; Geological Survey of Canada, Current Research 2008-9, 16 pages.
- Mortensen, J.K., 1993a. U–Pb geochronology of the eastern Abitibi Subprovince. Part 1, Chibougamau-Matagami-Joutel region. *Can. J. Earth Sci.* 30, pp. 11–28.
- Mortensen, J.K., 1993b. U–Pb geochronology of the eastern Abitibi subprovince. Part 2. Noranda-Kirkland lake area. *Can. J. Earth Sci.* 30, pp. 29–41.
- Mueller, W.U., Pearson, V., Mortensen, J.K., 2007. Évolution sous-marine du Groupe de Blake River: Nouvelles datation et caractéristiques des caldeiras Archéennes de Misema et de New Senator. *Recueil des résumés, Carrefour des Science de la Terre, Univ. Québec à Chicoutimi*, 45 pages.
- National Assembly, 2013. Bill 70 (2013, chapter 32) An Act to amend the Mining Act. Québec Official Publisher 2013. 32 pages.
- Pearson, V., and Daigneault, R., 2009, An Archean megacaldera complex: The Blake River Group, Abitibi greenstone belt, *Precambrian Research*, Vol. 168 (2009), pp. 66–82.
- Pearson, V. and Daigneault, R., 2006. A giant Archean caldera complex, the Blake River Group, Abitibi Subprovince; in *Abstracts of the Geological Association of Canada-Mineralogical Association of Canada Joint Annual Meeting*, Montreal, Quebec, pp. 116.
- Pearson, V., 2005. The Blake River Group: an imbricated caldera complex; in *Abstracts of Oral Presentations and Posters, Quebec Exploration 2005*, 45 pages.
- Péloquin, A.S., 2000. Reappraisal of the Blake River Group stratigraphy and its place in the Archean volcanic record, Ph.D. Thesis. Université de Montréal, Montréal, QC, Canada, pp. 282.

- Péloquin, A.S., Potvin, R., Paradis, S., Lafleche, M.R., Verpaelst, P., and Gibson, H.L., 1990. The Blake River Group, Rouyn-Noranda area, Quebec: a stratigraphic synthesis; in *The Northwestern Quebec Polymetallic Belt*, (ed.) M. Rive, P. Verpaelst, Y. Gagnon, J.M. Lulin, G. Riverin, and A. Simard; The Canadian Institute of Mining and Metallurgy, Special Volume 43, pp. 107-118.
- Poulsen, K.H., and Hannington, M.D., 1996, Volcanic-associated massive sulphide gold, in Eckstrand, O.R., Sinclair, W.D., and Thorpe, R.I., eds., *Geology of Canadian mineral deposit types: Geology of Canada*, vol. 8, pp. 183-196.
- Powell, W.D., Carmichael, D.M., and Hodgson, C.J., 1993. Thermobarometry in a subgreenschist to greenschist transition in metabasite of the Abitibi greenstone belt, Superior Province, Canada. *Journal of Metamorphic Geology*, Vol. 11, pp. 165-178.
- Price, P. 1956, Zone 5 resource estimates, Noranda Mines Ltd. internal communication.
- Price, P. 1955, Zone 5 resource estimates, Noranda Mines Ltd. internal communication.
- Price, P. 1954, Zone 5 resource estimates, Noranda Mines Ltd. internal communication.
- Price, P., 1934. The geology and ore deposits of the Horne Mine, Noranda, Quebec; *The Transactions of the Canadian Institute of Mining and Metallurgy and of the Mining Society of Nova Scotia*, v. 37, pp. 108-140.
- Price, P. 1933. The geology and ore deposits of the Home mine, Noranda, Quebec. Ph.D. thesis, McGill University, Montreal, Que. 1934.
- Purchase agreement of September 12, 2012, between Xstrata Canada Corporation (now Glencore Canada) and Falco.
- Roberts, L., 1956. Noranda. Clarke, Irwin and Company Ltd. Toronto, 223 pages.
- Ryznar, G., Campbell, F.A., and Krouse, H.R., 1967. Sulfur isotopes and the origin of the Quemont ore body; *Economic Geology and the Bulletin of the Society of Economic Geologists*, v. 62, pp. 664-678.
- Sansfaçon, R., Grenier, J. and Dallaire, M., 2011, Campagne de forage 2008, Propriété Stadacona-Est, SNRC 32D2-32D3, by Terrax Management, for Visible Gold Mines, GM-65885.
- Santaguida, F., 1999. The paragenetic relationships of epidote-quartz hydrothermal alteration within the Noranda Volcanic Complex, Quebec; Ph.D. thesis, Carleton University, Ottawa, Ontario, 302 pages.
- Sicard-Lochon, E., 1989, Résultats complémentaires sur la campagne de sondage 1986-1987, propriété Lac Tremoy, Canton Rouyn, Société Minière Écudor Inc., GM-49500.

- Sinclair, W.D., 1971. A volcanic origin for the No. 5 Zone of the Horne mine, Noranda, Quebec; *Economic Geology and the Bulletin of the Society of Economic Geologists*, v. 66, pp. 1225-1231.
- Spence, A.F., 1976. Stratigraphy, development and petrogenesis of the central Noranda volcanic pile, Noranda, Quebec; Ph.D. thesis, University of Toronto, Toronto, Ont., 166 pages.
- Spence, C.D., and de Rosen-Spence, A.F., 1975. The place of sulfide mineralization in the volcanic sequence at Noranda, Quebec; *Economic Geology and the Bulletin of the Society of Economic Geologists*, v. 70, pp. 90-101.
- Taylor, B.E., de Kemp, E., Grunsky, E., Martin, L., Maxwell, G., Rigg, D., Goutier, J., Lauzière, K., and Dubé, B., 2014. Three-dimensional visualization of the Archean Horne and Quemont Au-bearing volcanogenic massive sulphide hydrothermal systems, Blake River group, Quebec. *Economic geology and the bulletin of the Society of Economic Geologists* vol. 109, no. 1, 2014; pp. 183-203.
- Thurston, P.C., Ayer, J.A., Goutier, J., and Hamilton, M.A., 2008. Depositional gaps in the Abitibi greenstone belt stratigraphy: A key to exploration for syngenetic mineralization. *Economic Geology*, v. 103, pp. 1097–1134.
- Thurston, P.C., and Chivers, K.M., 1990. Secular variation in greenstone sequence development emphasizing Superior province, Canada: *Precambrian Research*, v. 46, pp. 21–58.
- Veillette, J.J., Paradis, S.J. and Thibaudeau, P. 2003, Les cartes de formations en surface de l'Abitibi, Québec; Geological Survey of Canada, Public file 1523.
- Weeks, R., 1967. Quemont Mining Corporation Limited; in *CIMM Centennial Field Excursion Northwestern Quebec-Northern Ontario*, (ed.) M.K. Abel; Canadian Institute of Mining and Metallurgy, Montreal, Quebec, pp. 46-51.
- Wilson, M.E., 1941. Noranda district, Quebec; Geological Survey of Canada, Memoir 229, 162 pages.

## 27.2 Underground Mining

- Arjang, B., Herget, G., 1997. In Situ Ground Stresses in the Canadian Hardrock Mines: an Update. *Int. J. Rock. Mech. & Min. Sci.* 34:3-4, paper No. 015
- Ballachey, A.G., Jamieson, W.D., and Hambleton, J.R., 1952. Mining at Quemont: The Canadian mining and metallurgical bulletin, v. LV, p.57-68, January 1952.
- BBA, 2017: Del Bosco, R., Thauvette, P., Roy, D., 2017. Drill & Blast Analysis and Design for Production Stopes. Report 3532004-000000-4M-ERA-0001/R00 prepared by BBA Inc. for Falco Resources Ltd., 40 pages.

- Consorem, Atlas Géophysique et Géologique De Gisement Au et Métaux de Base de la sous-province de l'Abitibi. [www.consorem.ca/production\\_s cien/2000\\_01/atlas\\_métaux.html](http://www.consorem.ca/production_s cien/2000_01/atlas_métaux.html).
- Corthésy, R., Leite, M.H., Gill, D., 1997. Élaboration d'un modèle de prédiction des contraintes in situ dans le Nord-Ouest Québécois, Études et recherches, IRSST, 56 pages.
- Falco Resources, Internal compilation table for Historical production at Horne (1927 to 1976).
- Girard, P-H. and InnovExplo, Pre-scoping Study Horne #5, report prepared for Falco Pacific Resource Group, dated September 2014.
- Golder Associates Ltd., 1981. Prediction of Stable Excavations for Mining at Depth below 1000 meters in Hard Rock. Ottawa: CANMET Energy Mines and Resources Department, File # DSS: OSQ80-0081 & DSS: 17SQ.23440-09020.
- Golder Associates Ltd., 2016a. Rock Mass Characterization and Classification – Horne Mine PEA Study, ref.no. GAL015-1541337-21010-TM-Rev0.
- Golder Associates Ltd., 2016b, Horne 5 Feasibility Study – Intact Rock Strength Testing, ref.no. GAL101-1541337-21130-TM-H5FS-Rev0.
- Golder Associates Ltd., 2017a, Horne 5 Feasibility Study – Crown Pillar Stability Assessments of the Historical Mines in the Horne Mine Area, ref.no. GAL019-1774165-2100-RA-Rev2.
- Golder Associates Ltd., 2017b, Étude hydrogéologique de référence Projet Horne 5. Rapport GAL186-1541337-Rev0.
- Golder Associates Ltd., 2017c. Étude hydrogéologique pour le dénoyage de mines Horne du projet Horne 5. Rapport GAL022-1774165-Rev0.
- Golder Associates Ltd. 2017d. Dewatering and Rheology Results and Backfill Design Basis. Technical Memorandum, GAL160-1541337-23190-Rev2.
- Gourd, Benoit-Beaudry, Le Klondyke de Rouyn et les Dumoulon. Travaux de recherche No 3, Cahiers du Département d'Histoire et de Géographie, Collège de l'Abitibi-Témiscamingue, Rouyn, May 1982.
- Gourd, Benoit-Beaudry, Mines et syndicats en Abitibi-Témiscamingue, Maitrise es art – Histoire, École des Études Supérieures et de la Recherche, Université d'Ottawa, 1978.
- Gagnon, G. and AMQ work group, 2013. Guide de dénoyage des mines souterraines. Report prepared for A.M.Q., dated February 2013.
- Hallboom, 2008. Pipe Flow of Homogenous Slurry. PhD Thesis. University of British Columbia. 233 p.
- International Society for Rock Mechanics (1981). Rock Characterization, Testing & Monitoring: ISRM Suggested Methods. Editor E. T. Brown, Pergamon Press, pp. 53-60.

- Landriault, D. 2001. Backfill in Underground Mining. *Underground Mining Methods – Engineering Fundamentals and International Case Studies* (Hulstrid W.A., and Bullock R.L.). Chapter 69, pp. 601-614.
- L'Écuyer, N., 1983, Sautage réalisé avec l'exploseur à synchronisation séquentielle à la Mine Chadbourne. 6e session d'étude sur les techniques de sautage de la SEEQ.
- Maloney et al., 2006. A Re-assessment of In Situ Stresses in the Canadian Shield, American rock mechanics association, ARMA/URMS 06-1096, 9 pages.
- Metcalfe, V., 2017. Commodity Price Assumptions – October 2017, dated October 3, 2017.
- Metcalfe, V., 2017. Commodity Price Assumptions – July 2017, dated July 17, 2017.
- Mitchell R.J., Olsen R.S., Smith J.D. 1982. Model studies on cemented tailings used in mine backfill. *Can. Geotech. J.*, Vol.19, No.1, pp. 14-28.
- Noranda Mines, internal monthly slag reports (sales and internal use), 1950 to 1969.
- Noranda Mines, internal monthly reports for tailings composition, 1952 to 1971.
- Patton F.E., Backfilling at Noranda, CIM bulletin, April 1952 (offprint).
- Piciacchia, L., 1987, Field and Laboratory studies of Mine Backfill Design Criteria, McGill University, PhD Thesis. Pages 87 to 90.
- Sabina, A.P. 2003, Commission Géologique du Canada, Roches et Minéraux du Collectionneur, Kirkland Lake – Rouyn Noranda – Val d'Or, Rapport divers 77.
- Sopko, J.A., Braun, B., and Chamberland, R., 2015. Largest Frozen Ground Excavation in North America for Excavation of Crown Pillar, internet: <http://groundfreezing.com/technical-papers/largest-frozen-ground-excavation-for-excavation-of-crown-pillar/>
- Veillette, J.J., Paradis, S.J., and Thibaudeau, P., 2003, Les cartes de formations en surface de l'Abitibi, Québec; Commission géologique du Canada, Dossier public 1523.
- Wasp, E.J., Kenny, J.P., Gandhi, R.L., 1977. Series on Bulk Materials Handling. Solid– Liquid Flow Slurry Pipeline Transportation, first ed., vol. 1 (1975/77). Trans Tech Publications.
- Wasp. E.J., Mc Camish, H.M. 1978. A perspective on coal slurry pipelines for the next decade. Paper presented at AIM Petroleum Institute Conference, Houston, TX, USA, 17-18 April.
- Wilson, K.C. and Thomas, A.D. 1985. A new analysis of the turbulent flow of non-Newtonian fluids, *The Canadian Journal of Chemical Engineering*, 63, pp. 539-546.
- Wilson, K.C. and Thomas, A.D. 2006. Analytic model of laminar-turbulent transition for Bingham plastics. *The Canadian Journal of Chemical Engineering*, 84, pp. 520-526.

Wilson, K.C., Addie, G.R., Clift, R. 1992. Slurry Transport Centrifugal Pumps. Springer. ISBN 978-1-85166-745-1.

### 27.3 Metallurgy and Process Plant

Air Liquide, Pre-oxidation and Cyanide Leaching of Pyrite Concentrate and tail, Project 15040-002, Feb. 13, 2017.

Cyanco Corporation, Test Program to Evaluate Cyanide Destruction Options using SO<sub>2</sub>/O<sub>2</sub> and Peroxygen-based Technologies for the Treatment of Effluents from the Horne 5 Project, February, 2017.

Doll, A.G, Comminution Modelling Report Horne 5 Project, AGD project number 0095, April 2, 2017.

InnovExplo Inc., BBA Inc., Technical Report and Updated Mineral Resource Estimate for the Horne 5 Deposit, January 8, 2016.

InnovExplo Inc., Technical Report and Mineral Resource Estimate for the Horne 5 Deposit, September 26, 2016.

Lehto, H., Outotec HIGmill test for Osisko Horne 5 ore sample. Draft report, April 25, 2016, 8 pages.

Pocock Industrial, Inc., Pulp Rheology and Pressure Filtration Studies Conducted for BBA – Falco Resources – Horne 5 Project, November 2016.

Starkey & Associates Inc., Horne 5 Project, SAGDesign Comminution Analysis and Mill Sizing Report, Rev 0, Project No. S191, April 22, 2016, 46 pages.

SGS Canada Inc., An Investigation into the Recovery of Copper, Zinc and Gold from the Horne 5 Deposit, Project 15040-001 – Final Report, November 10, 2016.

SGS Canada Inc., An Investigation into the Recovery of Copper, Zinc and Gold from the Horne 5 Deposit, Project 15040-002 – Final Report in progress.

SGS Canada Inc., An Investigation by High Definition Mineralogy into Gold Department and QEMSCAN Study on Four Composite Samples, Project 15040-001 – Final Report, March 11, 2016, 293 pages.

SGS Canada Inc., An Investigation by High Definition Mineralogy into Gold Department and QEMSCAN Study on Four Composite Samples, Project 15040-001 – Final Report, May 30, 2016, 319 pages.



Unité de recherche et de service en technologie minérale, May 2017, Test-work for cemented paste backfill and pyritic tailings disposal – Horne 5. Part 1: Physical, chemical and mineralogical characterizations, CPB preparation and compression tests (UCS), paste rheology, self-heating propensity and monolithic leaching tests. Report - Part 1. PU-2016-05-1067.

## 27.4 Infrastructure

ASHRAE handbook: Fundamentals, 2009, American Society of Heating, Refrigerating and Air-Conditioning Engineers, Atlanta, GA.

Brière, F.G., 2009, Distribution et collecte des eaux, 2ième édition revue et corrigée 2006. Presse international Polytechnique 2000: Réimpression 2009, (pp. 119-167).

Code de construction du Québec, chapitre 1 - Bâtiment, et code national du bâtiment - Canada 2010 (modifié) volumes 1 et 2.

Code de sécurité du Québec Chapitre VIII - Bâtiment, et code national de prévention des incendies - Canada 2010 (modifié).

F.E. Patton in a CIM bulletin report dated April 1952.

Golder Associates Ltd., 2017a. Water Management Plan – Falco Horne 5 Project – Feasibility Study, ref no. GAL041-1774165-Rev0.

Golder Associates Ltd. 2017b. HDS Design Report. ref no. GAL039-1774165-Rev0.

Golder Associates Ltd. 2017c. Feed and Sludge management Assessment. Ref no. GAL0037-1774165-Rev0.

Golder Associates Ltd. 2017d. Nitrogen Management Assessment for Horne Mine Dewatering. Ref no. GAL038-1774165-Rev0.

Groupe CSA, Code d'installation du gaz naturel et du propane, B149.1-15, août 2015.

Handscomb Yardsticks for costing 2016, Cost data for the Canadian Construction Industry.

MDDELCC., 1984, Captage et distribution d'eau, Directive 001. Ministère du développement durable, Environnement et Lutte contre les changements climatiques, 20 février 1984 pp.3-70.

MDDELCC., 1989, Réseaux d'égout, Directive 004. Ministère du développement durable, Environnement et Lutte contre les changements climatiques, 25 octobre 1989, pp.1.1-8.2.

Metal Mining Effluent Regulations, 2017. <http://laws-lois.justice.gc.ca/eng/regulations/SOR-2002-222/>

Ministère du Développement durable, de l'environnement et des parcs (MDDEP). 2012. Directive 019 sur l'industrie minière. ISBN : 978-2-550-64507-8 (PDF). 66 pages + appendices.

Mine and Mill Equipment Costs – An estimator's guide, 2012, USA, InfoMine USA inc, CostMine Division.

National Building Code, 2010, National Research Council of Canada, Canadian Commission on Building and Fire Codes, Ottawa.

QUÉBEC. First-aid Minimum Standards Regulation, Chapter A-3.001, r. 10, Éditeur officiel du Québec.

RSMMeans Square foot Costs 2016.

SNC-Lavalin Stavibel, Rapport étude de faisabilité Horne 5, 639514-0000-40ER-0001\_0C, mars 2017.

User's guide, National plumbing code of Canada, 2001, Ottawa: Canadian Commission on Building and Fire Codes, National Research Council of Canada Canadian.

Ville de Rouyn-Noranda, 2016, Exigences techniques et règlement municipaux.

## 27.5 Environment

Beaulieu, M. 2016. Guide d'intervention - Protection des sols et réhabilitation des terrains contaminés. Ministère du Développement durable, de l'Environnement et de la Lutte contre les changements climatiques. ISBN 978-2-550-76171-6 (PDF). 210 pages + appendices.

Canadian Dam Association. 2007. Dam Safety Guidelines.

Canadian Dam Association. 2014. Technical bulletin of the CDA on the "Application of Dam Safety Guidelines to Mining Dams"

Centre de données sur le patrimoine naturel du Québec (CDPNQ). 2015. Requête pour l'extraction de données du système Géomatique de l'information sur la Biodiversité.

Corporation Archéo-08. 2017. Étude du potentiel archéologique : Projet Horne 5, Ressources Falco Ltée, Rouyn-Noranda. 38 pages.

Environnement Canada and Ministère du Développement durable, de l'Environnement et des parcs du Québec (EC & MDDEP). 2007. Criteria for the Assessment of Sediment Quality in Quebec and Application Frameworks: Prevention, Dredging and Remediation. ISBN 978-0-662-47998-7 (PDF). 39 pages + appendices.

Environment Canada. 2009. Environmental code of practice for metal mines. ISBN 978-1-100-11901-4.

- Environment Canada. 2011. Guidelines for the Assessment of Alternatives for Mine Waste Disposal.
- Genivar. 2014. Plan de gestion des milieux humides situés dans les périmètres urbains de la Ville de Rouyn-Noranda. Report prepared for Ville de Rouyn-Noranda. 30 pages + annexes.
- Genivar. 2008. Étude d'impact sur l'environnement. Voie de contournement de Rouyn-Noranda – Route 117. Version finale. Report prepared for Ministère des Transports du Québec. 405 pages + appendices.
- Golder Associates Ltd., 1995. Caractérisation géochimique du parc à résidus de la mine Norbec. Rapport 951-7082 soumis à la Corporation Minière INMET en novembre 1995.
- Golder Associates Ltd., 1998. Plan de restauration environnementale du site Norbec d'Alembert, Québec Volumes 1 et 2 – Texte. Rapport 971-7075 soumis à Corporation Minière INMET, Division Lac Dufault en février 1998.
- Golder Associates Ltd., 2000. Rapport de conception, réhabilitation des digues nord, principale, G, H et X, Division Lac Dufault, Québec. Rapport 001-7030 soumis à Corporation Minière INMET, Division Lac Dufault.
- Golder Associates Ltd., 2017a. Étude hydrogéologique pour le dénoyage des mines du projet Horne 5. 20 p. GAL022-1774165-5100-Rev0.
- Golder Associates Ltd., 2017b. Water Management Plan – Falco Horne 5 Project – Feasibility Study, ref no. GAL041-1774165-Rev0.
- Golder Associates Ltd., 2017c. Surface Tailings Management Facility Design Report. GAL028-1774165-3100-Rev0.
- Golder Associates Ltd., 2017d . Climate Analysis – Falco Horne 5 Project. GAL001-1774165-4010-Rev0.
- International Council on Mining and Metals (ICMM). 2013. Adapting to a changing climate: implications for the mining and metals industry.
- Ministère du Développement durable, de l'Environnement, de la Faune et des Parcs (MDDEFP). 2013. Critères de qualité de l'eau de surface, 3ème édition, Québec, Direction du suivi de l'état de l'environnement. IBN 978-2-550-68533-3 (PDF). 510 pages + appendices.
- Ministère du Développement durable, de l'environnement et des parcs (MDDEP). 2006. Note d'instruction 98-01 sur le bruit. Traitement des plaintes sur le bruit et exigences aux entreprises qui le génèrent. 23 pages.
- Ministère du Développement durable, de l'environnement et des parcs (MDDEP). 2012. Directive 019 sur l'industrie minière. ISBN : 978-2-550-64507-8 (PDF). 66 pages + appendices.

- Ministère du Développement durable, de l'Environnement et de la Lutte contre les changements climatiques (MDDELCC). 2015. Guide de caractérisation physicochimique de l'état initial du milieu aquatique avant l'implantation d'un projet industriel, Direction du suivi de l'état de l'environnement. ISBN 978-2-550-73838-1. 12 pages + appendices.
- Ministère du Développement durable, de l'Environnement et de la Lutte contre les changements climatiques (MDDELCC). 2016. Critères de la qualité de l'eau de surface. Web site: [http://www.mddelcc.gouv.qc.ca/Eau/criteres\\_eau/index.asp](http://www.mddelcc.gouv.qc.ca/Eau/criteres_eau/index.asp).
- Ministère du Développement durable, de l'Environnement et de la Lutte contre les changements climatiques. 2017. Système d'information hydrogéologique. <http://www.sih.mddep.gouv.qc.ca/index.html>
- Ministère de l'Énergie et des Ressources Naturelles (MERN). 2016. Guide de préparation de réaménagement et de restauration des sites miniers au Québec. Direction de la restauration des sites miniers. ISBN: 978-2-550-77162-3 (PDF). 56 pages + appendices.
- National Building Code of Canada (NBCC) 2010.
- Parkhurst, D.L. and Appelo, C.A.J., 1999, User's guide to PHREEQC (version 2)--A computer program for speciation, batch-reaction, one-dimensional transport, and inverse geochemical calculations: U.S. Geological Survey Water-Resources Investigations Report 99-4259, 312 p.
- Secrétariat aux affaires autochtones du Québec (SAAQ). 2012. Entente de principe sur la consultation et l'accommodement. Internet link consulted on February 18, 2016: [http://www.autochtones.gouv.qc.ca/rerelations\\_autochtones/ententes/algonquins/20120425-lac-simon-pikogan.htm](http://www.autochtones.gouv.qc.ca/rerelations_autochtones/ententes/algonquins/20120425-lac-simon-pikogan.htm).
- Unité de recherche et de service en technologie minérale, May 2017. Test-work for cemented paste backfill and pyritic tailings disposal – Horne 5. Part II : Environmental Aspects, Net acid generation and Humidity cell tests. Report- part 2. PU-2016-05-1067.
- US Army Corps of Engineers. 1984. Rationalizing the Seismic Coefficient Method. Waterways Experiment Station. July 1984.
- Veillette, J,J., Paradis, S,J., et Thibaudeau, P., 2003, Les cartes de formations en surface de l'Abitibi, Québec; Commission géologique du Canada, Dossier public 1523.
- Ville de Rouyn-Noranda. 2015a. Schéma d'aménagement et de développement révisé, 2010. 180 pages + appendices.
- Ville de Rouyn-Noranda. 2015b. Règlement de zonage numéro 2015-844. 308 pages + appendices.

---

WSP Canada Inc. 2017a. Évaluation des effets du rejet des débits de dénoyage et de maintien à sec du projet Horne 5 sur le cours d'eau Dallaire. Technical Note, preliminary version, prepared for Falco Resources Ltd. 7 pages.